



APEX
CHASSIS

The **Confidence** To Get You Out
The **Engineering** To Get You Home

APEX# BJ130 (MOOG K7460)

RE-ENGINEERED EXTREME DUTY UPPER BALL JOINT

APPLICATIONS:

Dodge	RAM 1500 Truck	2006-2008	Ram	2500	2011-2019
	RAM 2500 Truck	2003-2010		3500	2001-2019
	RAM 3500 Truck	2003-2010			

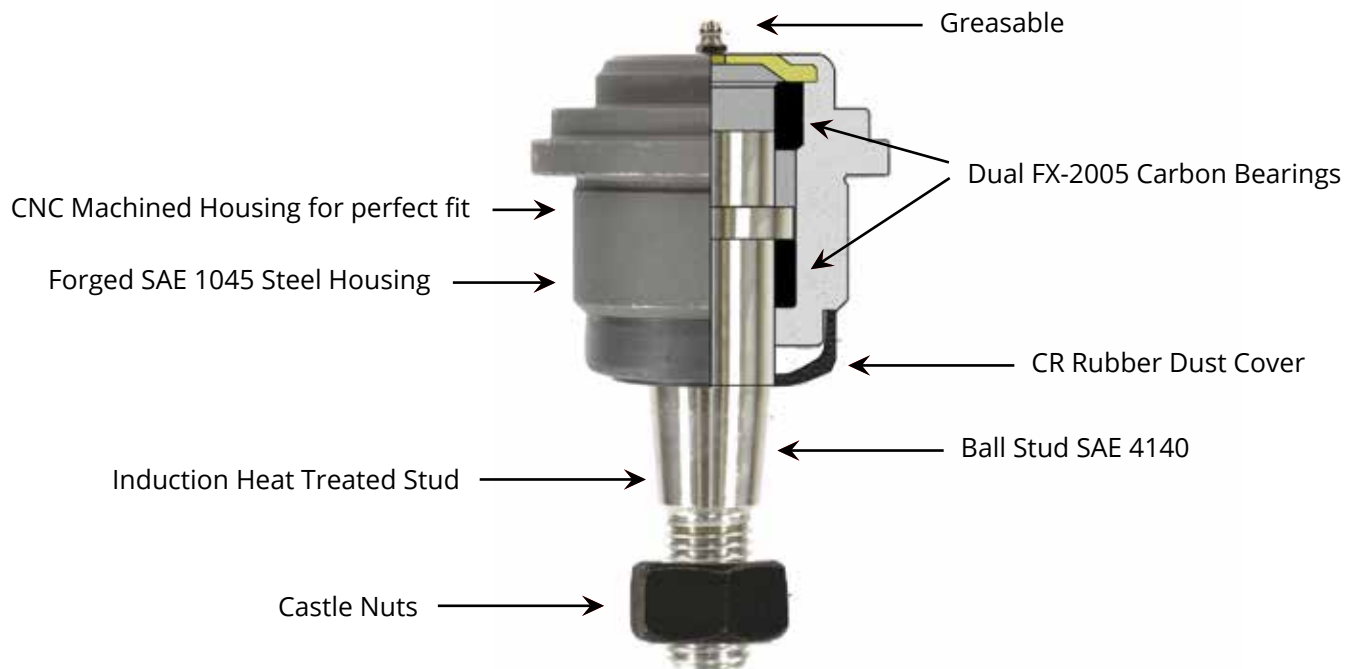



The **Confidence** To Get You Out
The **Engineering** To Get You Home

**WHAT DO APEX ZERO LASH™ BALL JOINTS
MEAN TO A SUPER DUTY FORD TRUCK OWNER?
ABOUT 300,000 TO 400,000 MILES!**

APEX Ball Joints cost less, last longer and are easier to install. Don't take our word for it, Google "XRF Ball Joints" and see what the world is saying about us.





APEX
CHASSIS

The **Confidence** To Get You Out
The **Engineering** To Get You Home

WHEN YOU'RE THIS STRONG & CONFIDENT,
YOU DON'T MIND WEARING PINK

EXPLORE WITH US

Pink Jeep Tours runs fully loaded adventures every day, from sunrise to sunset.
And they trust **XRF** ball joints to get the job done on Arizona's toughest terrain.



APEX
CHASSIS

The **Confidence** To Get You Out
The **Engineering** To Get You Home

warranty statement



APEX
CHASSIS

The **Confidence** To Get You Out
The **Engineering** To Get You Home

K3134 tx



APEX
CHASSIS

The **Confidence** To Get You Out
The **Engineering** To Get You Home

EXTREME DUTY TIE ROD ASSEMBLY

BUILT BORDER PATROL TOUGH!!!
WITH MORE THAN DOUBLE THE STEEL
AND STRENGTH OF OE DESIGN

FEATURES:

- More than double the size
- Sealed accordion boot design at both ends
- Greaseable inner and outer ends
- SAE1045 & SAE4140 high-strength mid-carbon steel



Part #	Description	Per car	Years	Applications
20-04758X	Tie Rod End Assembly	2	2013-2001	Chevrolet Avalanche 2500 (2006-2002); Silverado 1500 HD (2006-2001); Silverado 2500 (2004-2001); Silverado 2500 HD (2010-2001); Silverado 3500 (2006-2001); Silverado 3500 HD (2010-2007); Suburban 2500 (2013-2001); GMC Sierra 1500 HD (2006-2001); Sierra 2500 (2004-2001); Sierra 2500 HD (2010-2001); Sierra 3500 (2006-2001); Sierra 3500 HD (2010-2007); Yukon XL 2500 (2013-2001); Hummer H2 (2007-2003)
20-04757X	Tie Rod End Assembly	2	2006-1999	Cadillac Escalade (2006-2002); Escalade ESV (2006-2003); Escalade EXT (2006-2002); Chevrolet Avalanche 1500 (2006-2002); Silverado 1500 (2006-1999); Silverado 2500 (2000-1999) [4WD]; Suburban 1500 (2006-2000); Suburban 2500 (2000-2000) [4WD]; Tahoe (2006-2000); GMC Sierra 1500 (2006-1999); Sierra 2500 (2000-1999) [4WD]; Yukon (2006-2000); Yukon XL 1500 (2006-2000); Yukon XL 2500 (2000-2000) [4WD]

** When upgrading from OE or Standard design replace in pairs

*** Standard inner and outer tie rods also available for this application