

DIMENSION 50mm IS TRACK WIDTH.
ALLOW 1mm GAPS EITHER SIDE FOR
MOVEMENT.

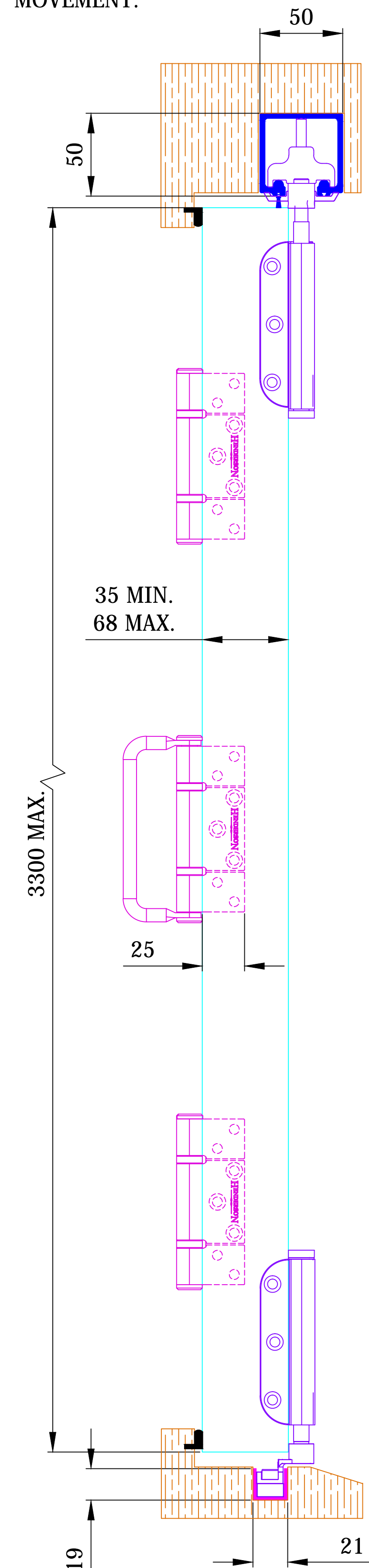

WHEN USED IN CONJUNCTION WITH THE ALUMINIUM SUPPORT CHANNEL
94SC, THE OUT DIMENSION BECOMES 23H X 25W.

**OPTIONAL
ALUMINIUM
THRESHOLD**

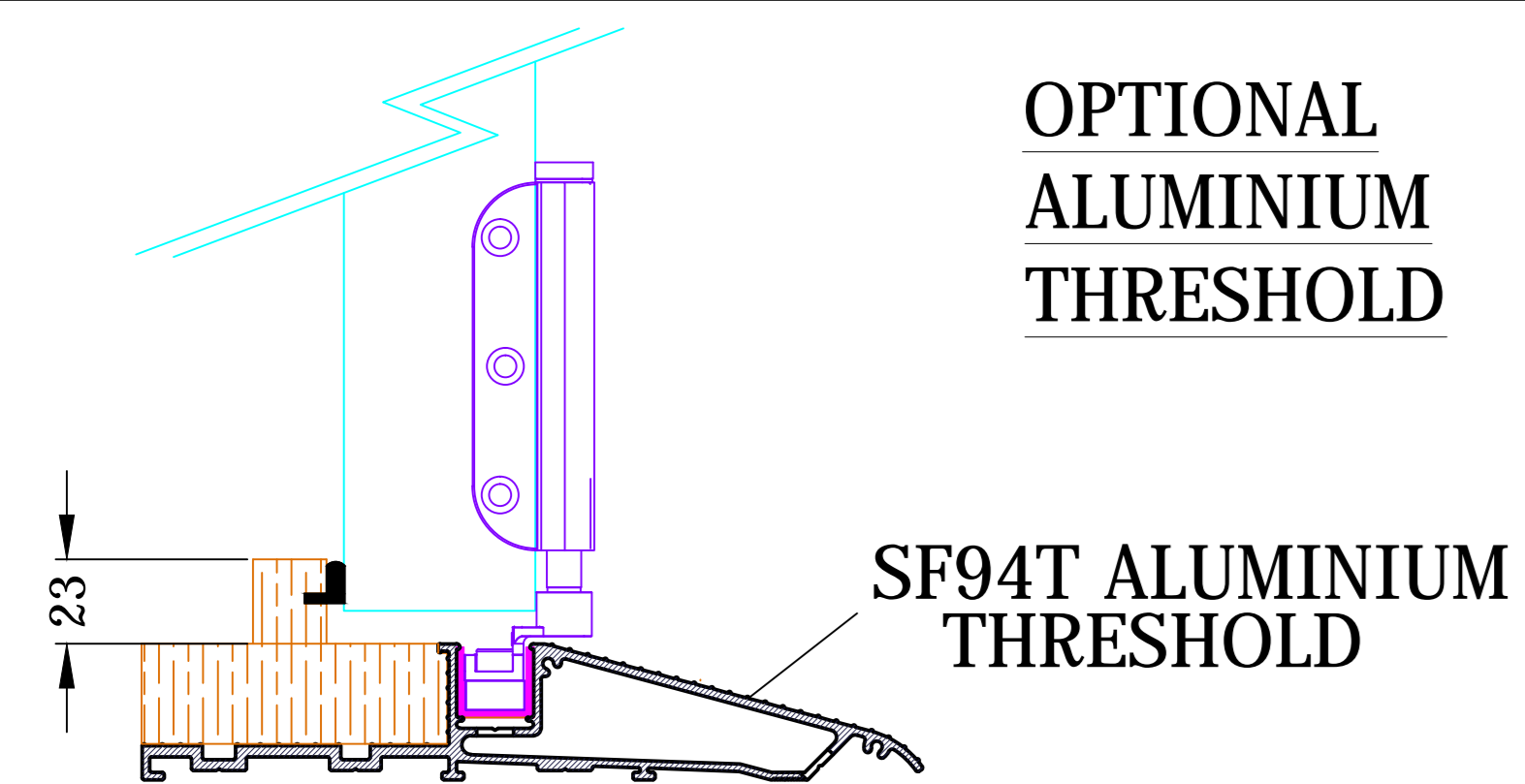

OPTIONAL JAMB KIT ASSY

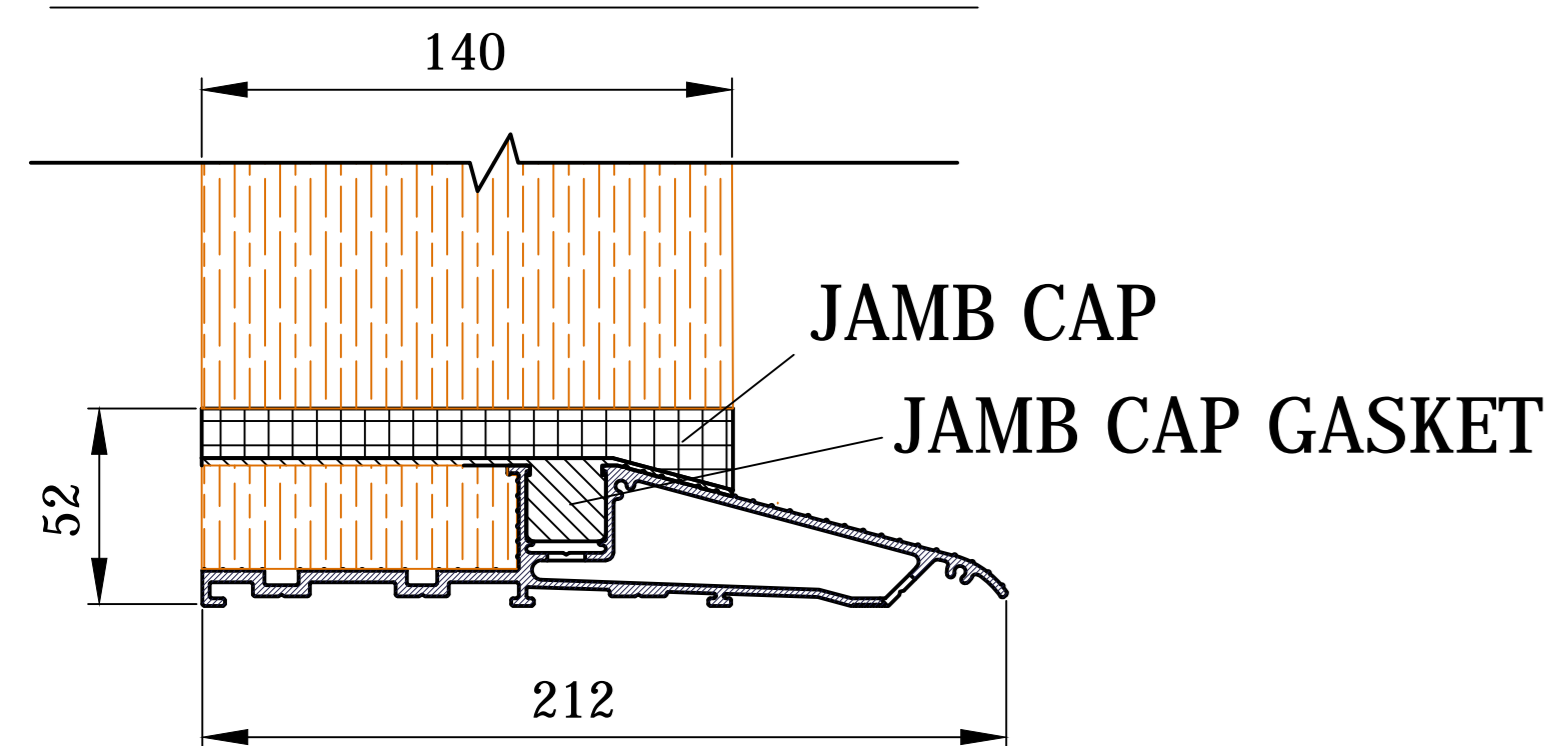

ALTERNATIVE ALUMINIUM THRESHOLD COMES COMPLETE
WITH 94P AND ENDCAPS AND IS PREDRILLED FOR DRAINAGE

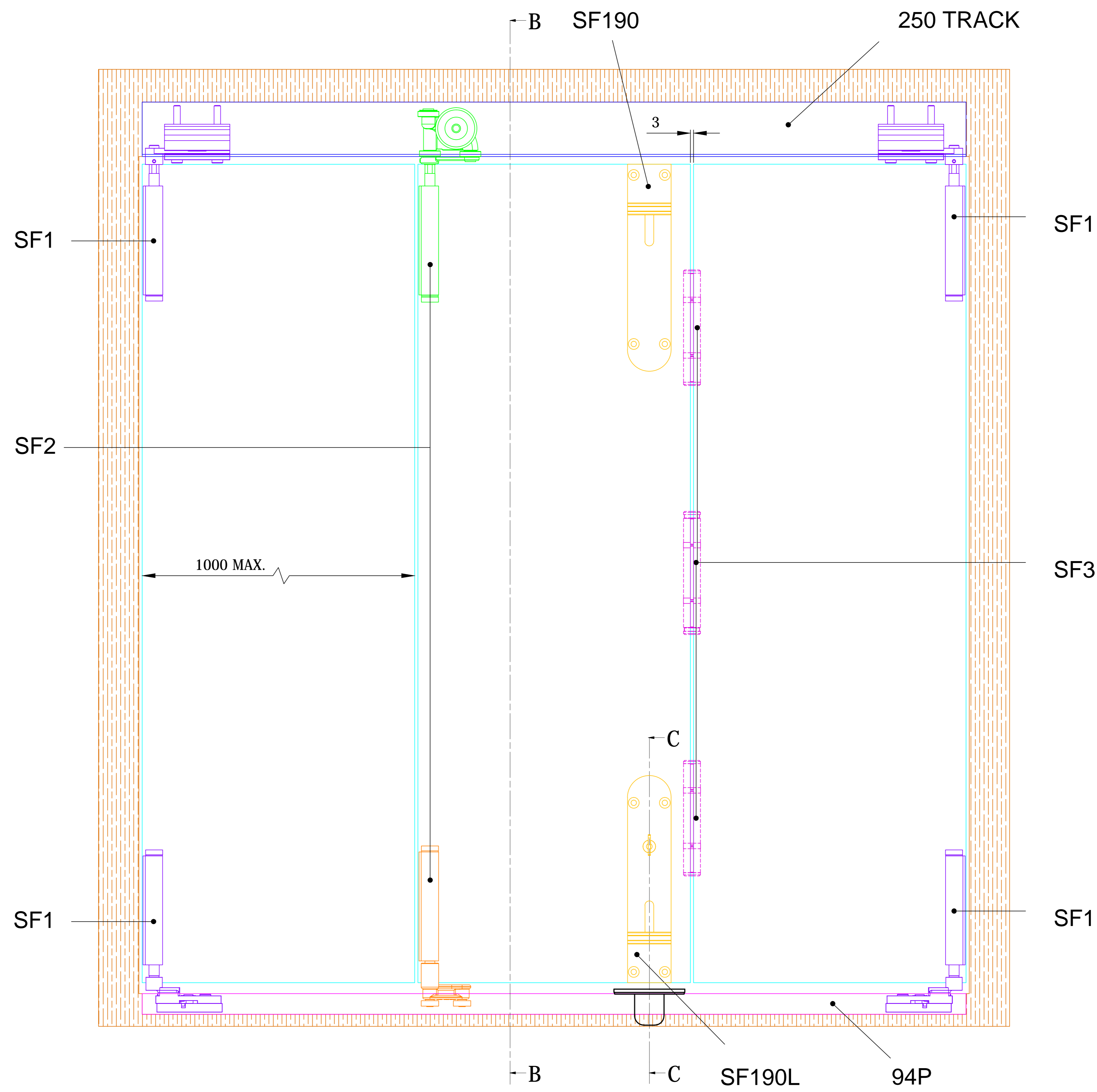

SECTION B-B

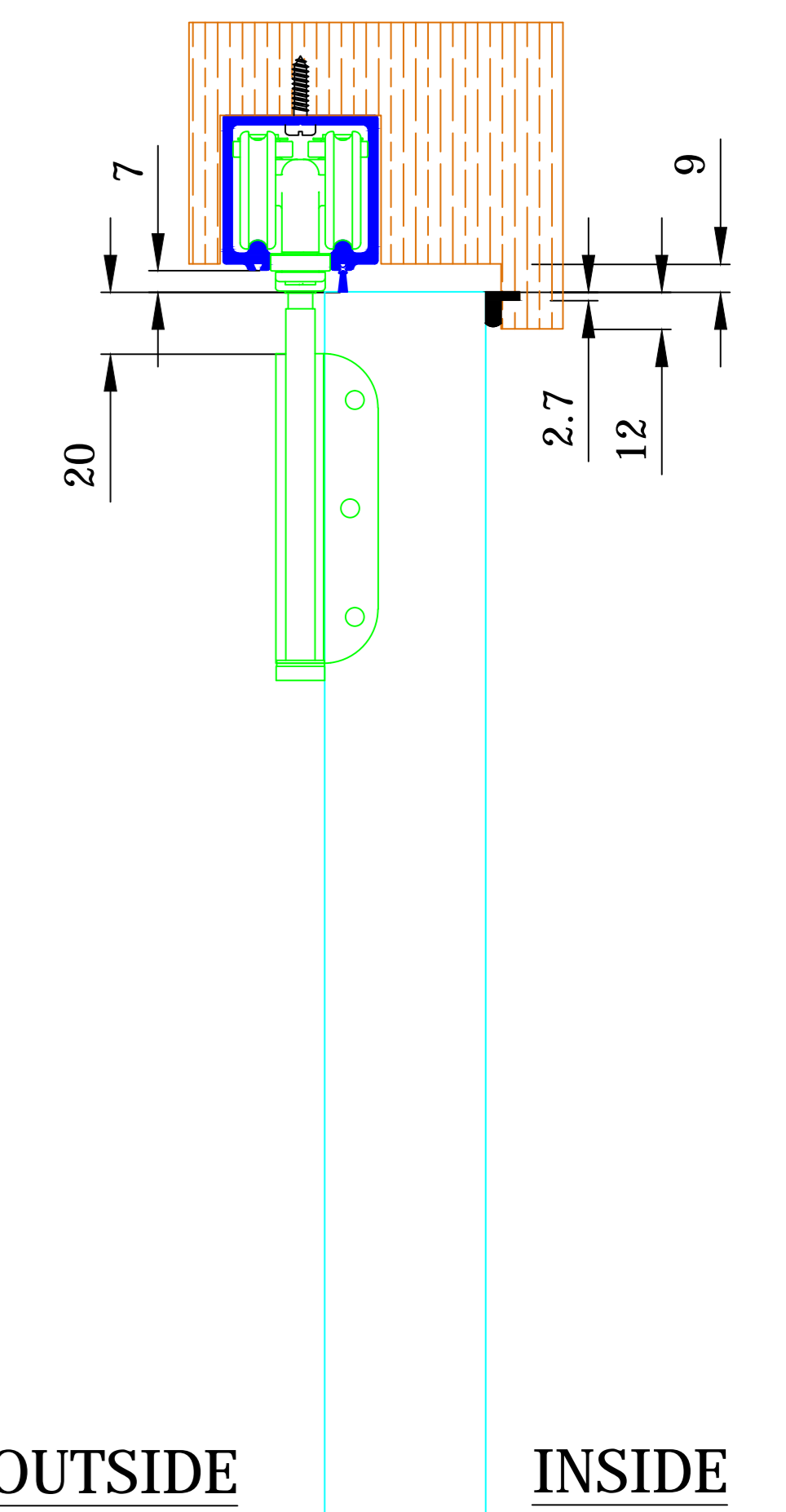

OUTSIDE **INSIDE**

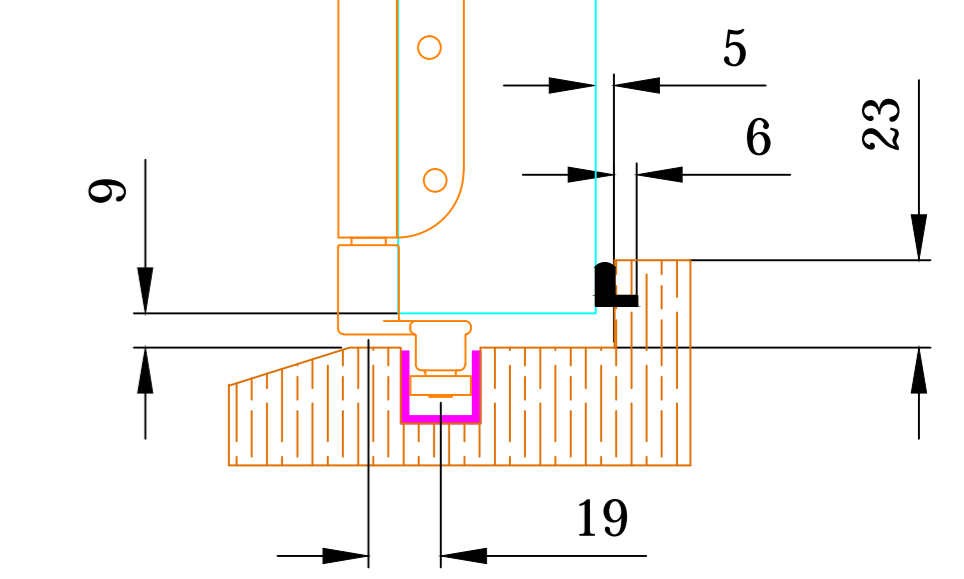

SECTION C - C

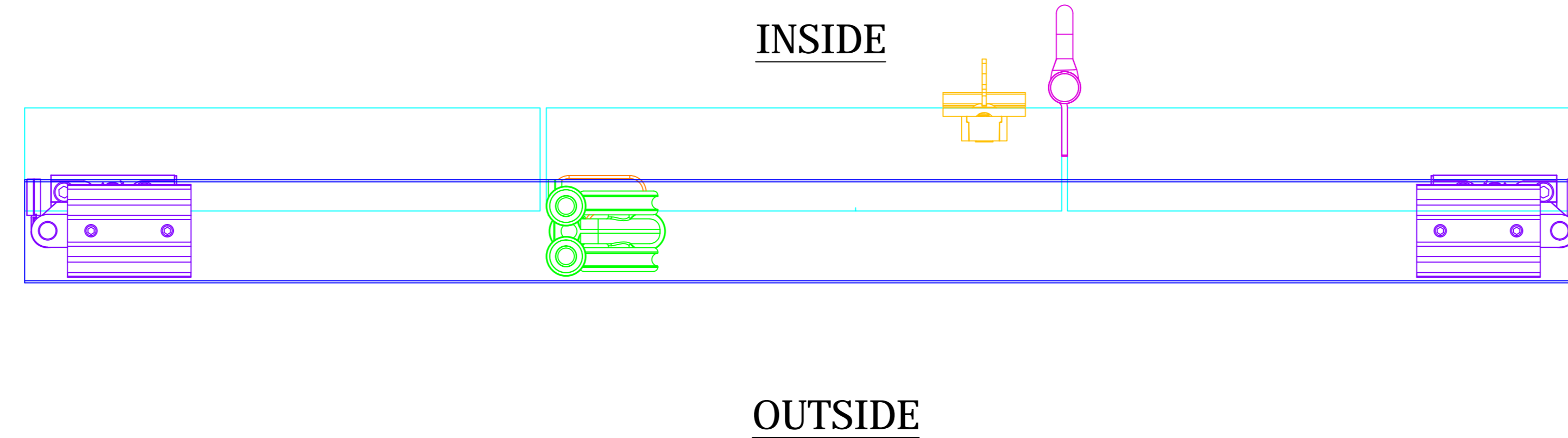
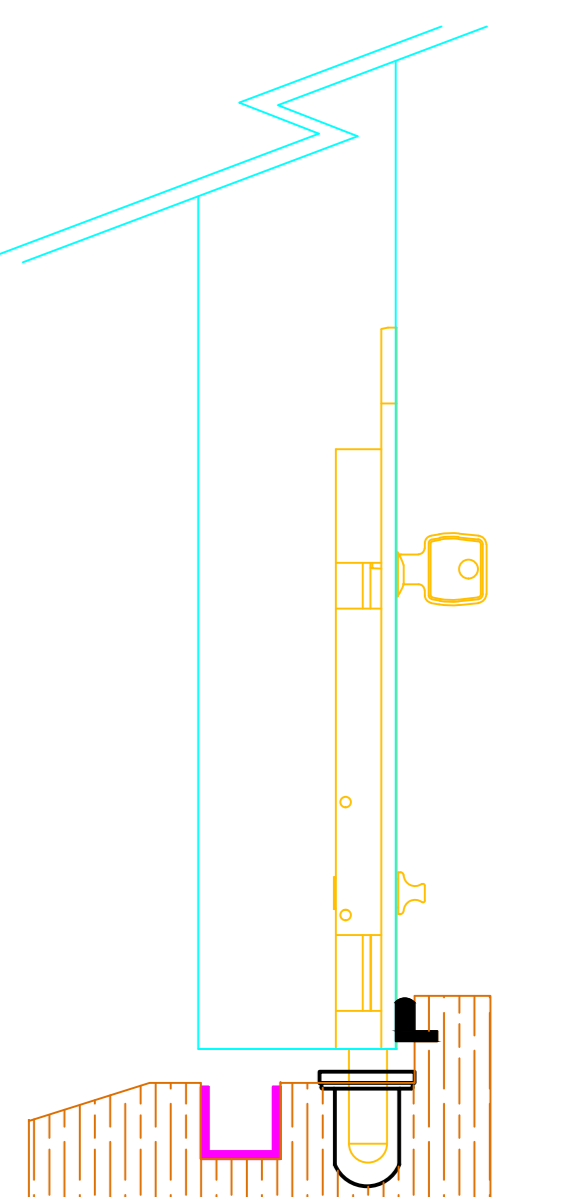

**VIEW E: EXAMPLE
REBATED DOOR**

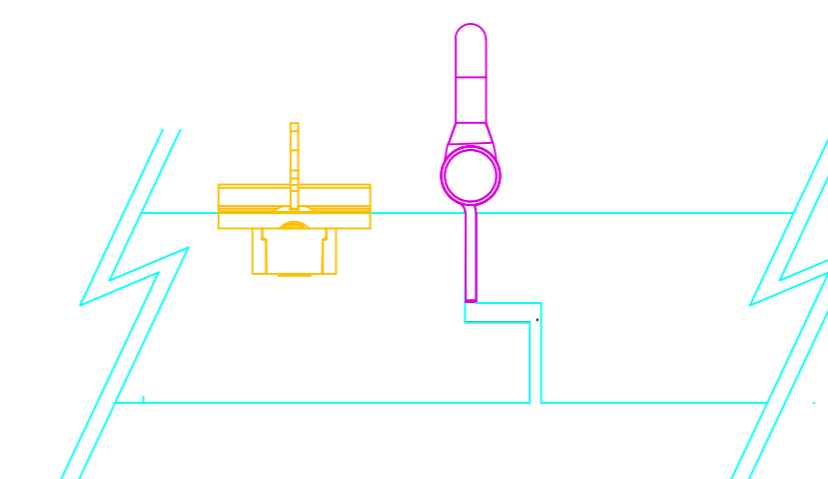

NOTES:

1. DRAWING IS FOR REFERENCE AND SUBJECT TO CHANGE WITHOUT NOTICE.
2. APPLICATION IS FOR EXTERNAL TIMBER FOLDING DOORS WEIGHT MAX 100Kg.
3. SQUARE EDGE DOORS ARE SHOWN, SYSTEM CAN BE USED ON REBATED DOORS - REBATE SHOULD BE OPPOSITE SIDE TO HARDWARE - SEE VIEW E.
4. REFER TO FITTING INSTRUCTIONS FOR ROUTING DETAILS REQUIRED
5. 190mm FLUSHBOLTS SHOWN ALTERNATIVE SIZES ARE AVAILABLE - 450 AND 600mm.
6. FOR DOORS BETWEEN 35-47mm THICK AT ALTERNATIVE TO THE SECUREFOLD FLUSHBOLT IS REQUIRED.
7. ALL DIMENSIONS ARE IN MILLIMETERS.

Description:	SECUREFOLD OUTWARD OPENING 1+2
PCH-code:	SF O/W 1+2
CAD-scale:	----
Drawing-size:	A0
Revision:	A

HENDERSON

www.pchenderson.com