

HENDERSON

INSTRUCTION MANUAL

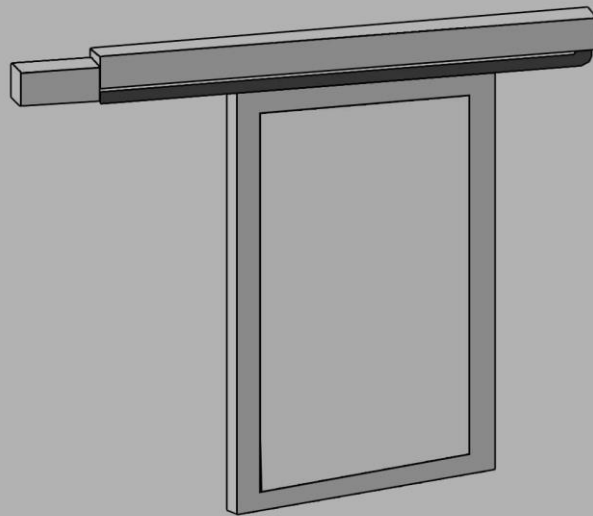

Evolve Motor and Wiring Instructions
Prometheus XS-2/STR/MDG

1 About this document

1.1.1 Target group

This document addresses qualified personnel only. The mounting must be done by technical educated, trained and qualified personnel. Electrical wirings have to be done by a specialist.

This document has to be made accessible for qualified personnel. Its content must be read, understood and followed.

1.1.2 Objective of this document

This document contains important information for mounting and wiring of the product. It has to be read before working with the product. It must be handed out and explained to the operator and kept available all the time as a part of the product.

1.1.3 Reference to other documents, guidelines and standards

Additional documents like guidelines, standards and laws for products of this kind, have to be considered.



Hint

The fabricator has an increased duty to advice the customer. The relevant guidelines, standards and laws have to be considered.

1.1.4 Used symbols



Hint

A hint gives important and additional information.

NOTICE

Description of type and source of hazard

Warnings, marked with this symbol, are related to safety.

Disregard may result in property damage.

➤ Steps to avoid hazards.

CAUTION



Description of type and source of hazards

This symbol indicates a hazardous situation which, if not avoided, could result in minor or moderate injury and/or property damage.

The following levels of warning show the severity and probability of possible hazards, in ascending order.

- CAUTION, colored yellow
- WARNING, colored orange
- DANGER, colored red

➤ Steps to avoid hazards.

Lists

- Symbolizes a list with no specific order.
1. Symbolizes a list or instruction in specific order.

Instructions

- Symbolizes an action.
 - Symbolizes a reference.
- ✓ Symbolizes the result of an action.

2 Safety

DANGER



Electric Shock

Danger to life and health due to electrical shock.

- Electrical connections have to be installed by approved personnel only.
- Switch off power before carrying out work and secure power against being switched on.
- Observe relevant safety instructions.

2.1 Requirements for operation



Hint

Read the instruction manual before performing the initial operation

2.1.1 Environmental conditions

The Prometheus XS-2/STR/MDG motor control device for sliding doors is designed for standard wall jacks in dry interior.

2.2 Proper use

This product is a motor control device for the sliding door Prometheus XS2 of the manufacturer. The manufacturer's specifications must be respected, in especially maximum and minimum dimensions and maximum weight of the door leaf.

Any other use of this product is considered inappropriate use.

It is not guaranteed, that this product will work in combination with fittings, motors or other electronic devices of other manufacturers.

2.3 Behavior in case of an error

In case of an error, the device must be shut down and the manufacturer must be informed.

Shut down

- Do not operate device.
- Disconnect device from power supply.
- Inform the manufacturer.

3 Functional description

3.1 General description

The product Prometheus XS2 is an electric drive for sliding doors. The motor control device Prometheus XS2/STR drives a 24V DC motor. The motor drives a sliding door, to which it is connected by a timing belt.



Hint

This document describes the functionality of the motor control device Prometheus XS2/STR. Instruction manuals for the installation of the mechanical parts of the sliding door are available in separate documents.

The control device is designed to fit in a standard flush box, according to DIN 49073. The control device disappears into the flush box, including its electrical connections. For operation a removable switch is provided, which fits into commercial available switch ranges with standard dimensions of 55 x 55 mm².

The control device is powered by an external power supply unit. The PSU supplies 24V DC and is connected to terminals 1 and 2. It can be placed in a flush box next to the control device. A distant mounting is also possible. For information on the wiring, refer to chapter 4.

For electrical connections, screw terminals are provided. These are grouped by their function: Power supply (Terminals 1 and 2), Control inputs (Terminals 1, 15, 21 and 29), Motor (Terminals MA and MB) and Encoder (Terminals 1, 82, 85 and 86).

The encoder of the motor Prometheus XS2 has to be connected, to ensure proper operation.

The control device provides a potentiometer P1, to set the time the door stays open (automatic mode only). The operation mode is selected by a DIP switch.

To perform the initial operation or to apply new settings, the reset key is used.



Hint

For further information on configuration and initial operation, refer to chapter 6.

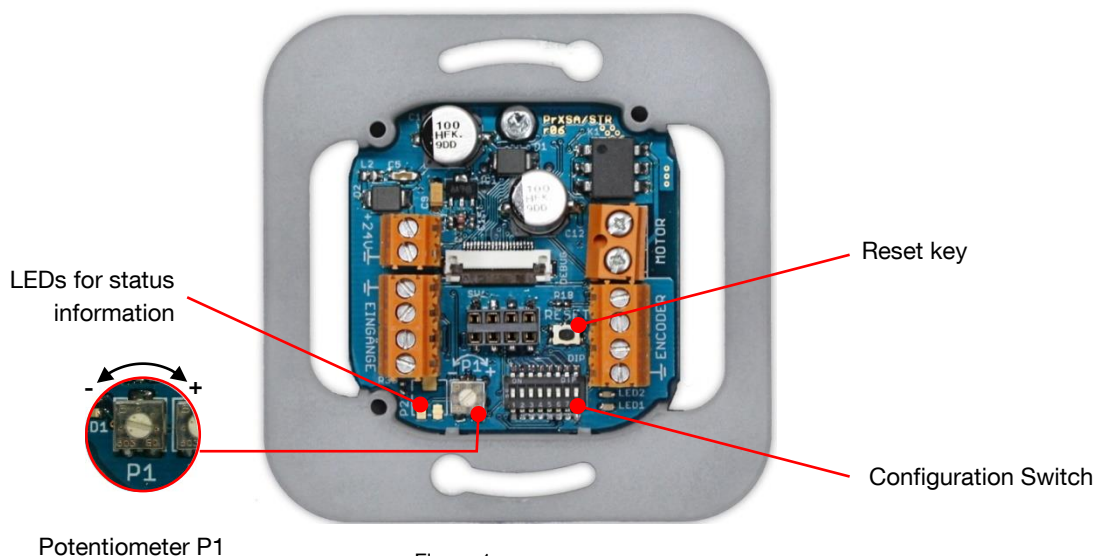

Figure 1
Motor control device

3.2 Modes of operation

After installation and initial operation, the motor control device is ready to use.

The door drive starts to move, when the keys “open” or “close” of the switch cover are pressed, or when the potential free inputs (Terminals 1, 21 and 29) are triggered.

The following modes of operation are possible:

- **Dead man’s control:**
The drive moves in the desired direction, as long as the corresponding input signal is applied and no obstruction is detected. Otherwise it stops instantly.
- **Semi-automatic mode:**
The drive moves in the desired direction after a trigger impulse on the corresponding input signal. After an opening command, it will stay open until a close command is applied.
When an obstruction is detected or a stop signal or a command contrary to the driving direction is applied, the drive stops.
- **Automatic mode:**
Additional to the semi-automatic behavior, the door closes automatically, when a close delay time is over. When an obstruction is detected during closing, the drive reverses and remains open for the close delay time again.
If a command contrary to the driving direction is given, the drive reverses. On a stop signal, the drive will stop as long as the stop input is applied. After the stop signal is released, the drive continues its operation.
- **Temporarily remain opened:**
In automatic mode it is possible to let the door remain in the open position.
To activate this feature it is necessary to press the “Open” and “Close” keys together for about two seconds. After this, the door remains in the open position, until a close command is given. After closing, the drive returns to automatic mode.

4 Wiring

4.1 Wire diagram

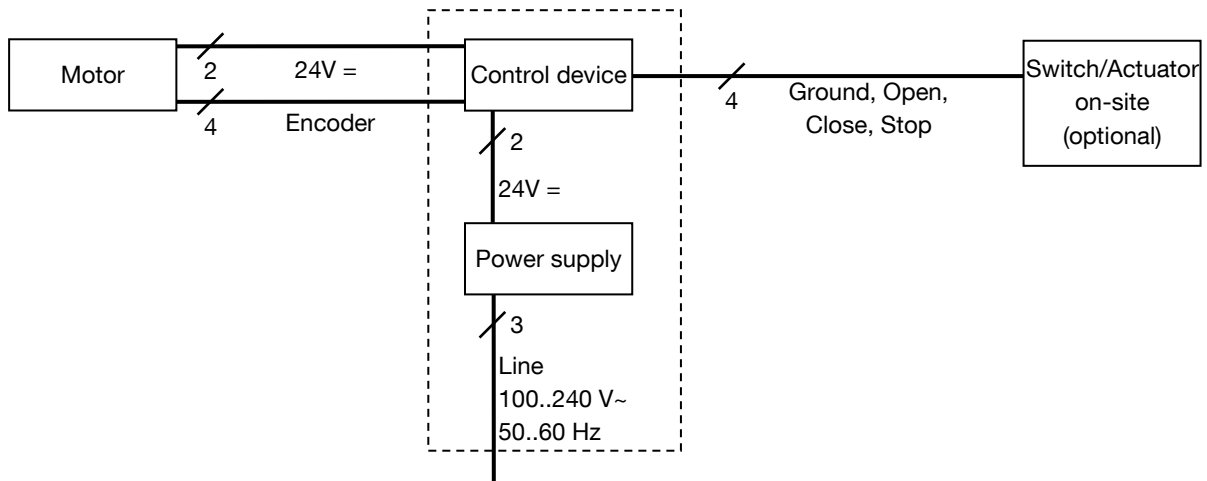

Usually the control device and the power supply are mounted in two neighboring flush boxes.

4.2 Wire requirements

The following specifications are minimum requirements.

For motor wiring a special wire is recommended, which fulfills the requirements. It is available from the manufacturer.

Wire	Wire type
Between motor and control device.	Motor supply (24V =) up to 20 m (60 ft): 2 x 0,50 mm ² (20 AWG) 20 to 50 m (60..160 ft): 2 x 0,75 mm ² (18 AWG)
	Encoder up to 50 m (160 ft): 4 x 0,25 mm ² (22 AWG)
Between switch/actuator and control device.	optional up to 50 m (160 ft): 4 x 0,25 mm ² (22 AWG)
Between power supply and control device.	up to 20 m (60 ft): 2 x 0,50 mm ² (20 AWG) 20 to 50 m (60..160 ft): 2 x 0,75 mm ² (18 AWG)

Table 1 – Wire requirements

5 Mounting and electrical connection

5.1 Mounting in a flush box

DANGER



Electric shock

Danger of dead, serious injury or property damage.

- Wiring must be done by authorized and trained personnel only.
- Shut down main power before carrying out any work on wiring.



Hint

Wires of the mains AC line and 24 V SELV are not allowed to cross each other without additional insulation.

- Insulate wires with heat shrink tube or ductwork, if applicable.

5.1.1 Safety precautions

- The motor control device Prometheus XS2/STR is designed for non-portable applications.
- There must be an all-pole mains switch on site, to disconnect the motor control device from main power.
- A 10 A automatic circuit breaker must be installed in the power path of the motor control box.

5.1.2 Mains connection diagram

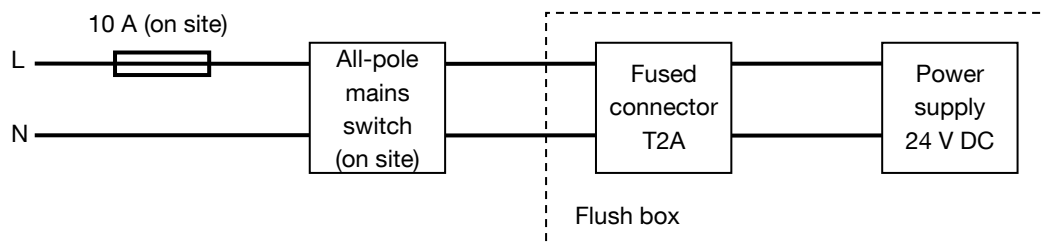

5.2 Mounting of control unit and power supply

Mounting of power supply unit (PSU) in a flush box

- Put PSU in neighboring flush box.
 - Pay attention to requirements of PSU manufacturer.
- Connect power line to PSU (brown and blue wires).
- Bring leads for 24 V (red and black leads) into flush box for control device.
- ✓ Power supply is mounted and ready for operation.

Mounting of control device and switch cover

- Prepare cables of power supply and motor for connection.
- Put control device in flush box.
- Carry out electrical connections.
 - For details refer to chapter 5.3
- Secure control device with two screws.
- Perform initial operation.
 - For details refer to chapter 6.2
- Place cover frame over control device.
- Plug switch through cover frame into control device.
- ✓ Control device and switch are mounted.

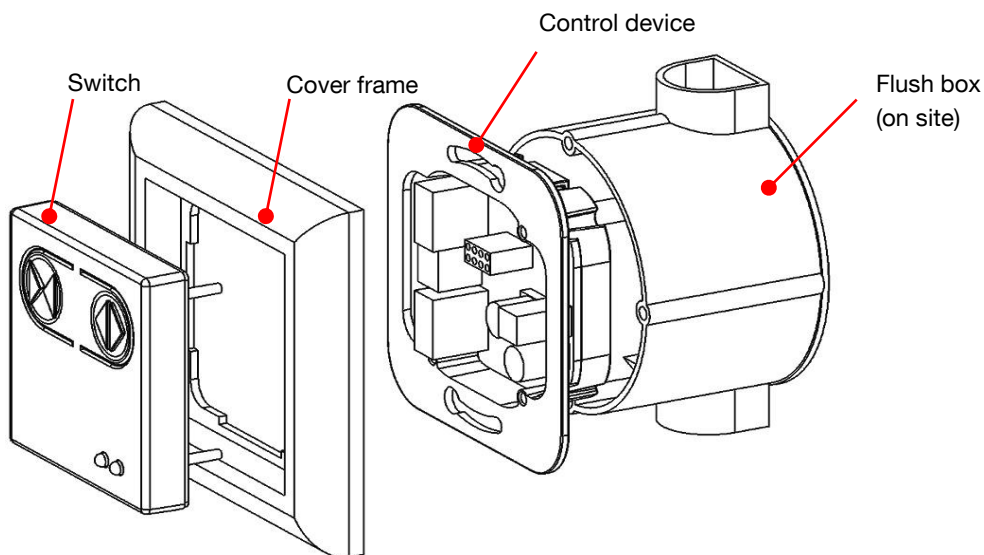

Figure 2 – Mounting of control device and switch

HENDERSON

5 Mounting and electrical connection

5.3 Electrical connection

⚠ CAUTION



Wrong installation

Damage of control device.

- Observe polarity of connections.
- Inputs (Terminals 1, 15, 21, 29) are potential free.

Carrying out electrical connections

- Disconnect main power and protect against power up.
→ For safety instructions refer to chapter 2.
- Connect power supply to terminals 1 and 2.
Terminal 2: 24V DC (+)
Terminal 1: Ground (-)
- Connect motor to terminals MA and MB.
Polarity determines direction of operation.
- Connect encoder.
Terminals 82, 86, 85 and 1
- Connect on-site actuators (optional)
Terminals 1, 15, 21 and 29

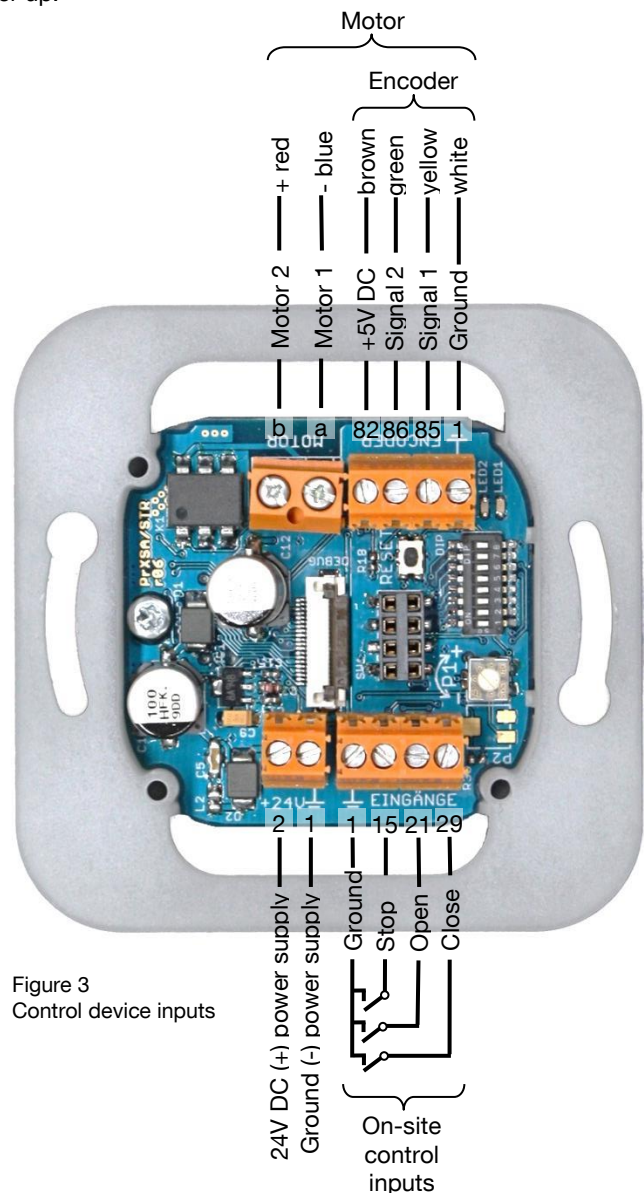

Figure 3
Control device inputs

5.3.1 Exemplary connection of on-site actuators

⚠ CAUTION



Wrong installation or initial operation.

Damage of control device or actuators.

- Read documents of actuators manufacturer.
- In case of questions contact manufacturer.

Motion detection example: Bircher Reglomat PrimeMotion C



Hint

Further information, especially mounting and initial operation of the motion detector, are available in the instruction manual of the manufacturer.

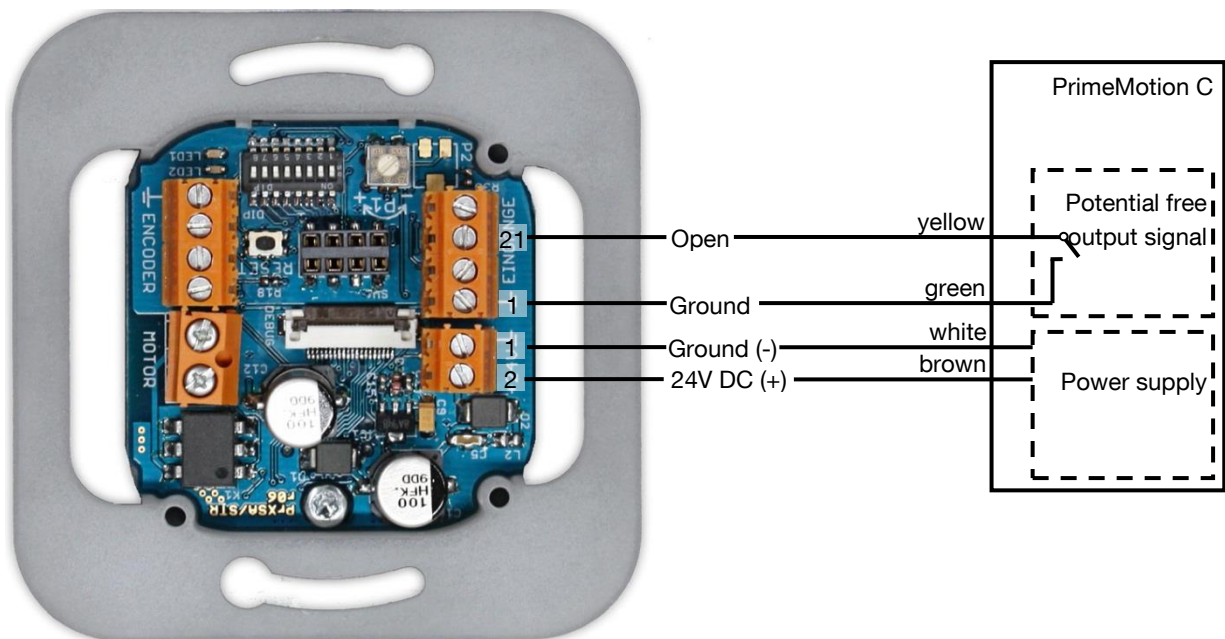

HENDERSON

5 Mounting and electrical connection

Conventional open and close buttons (potential free, normally open).

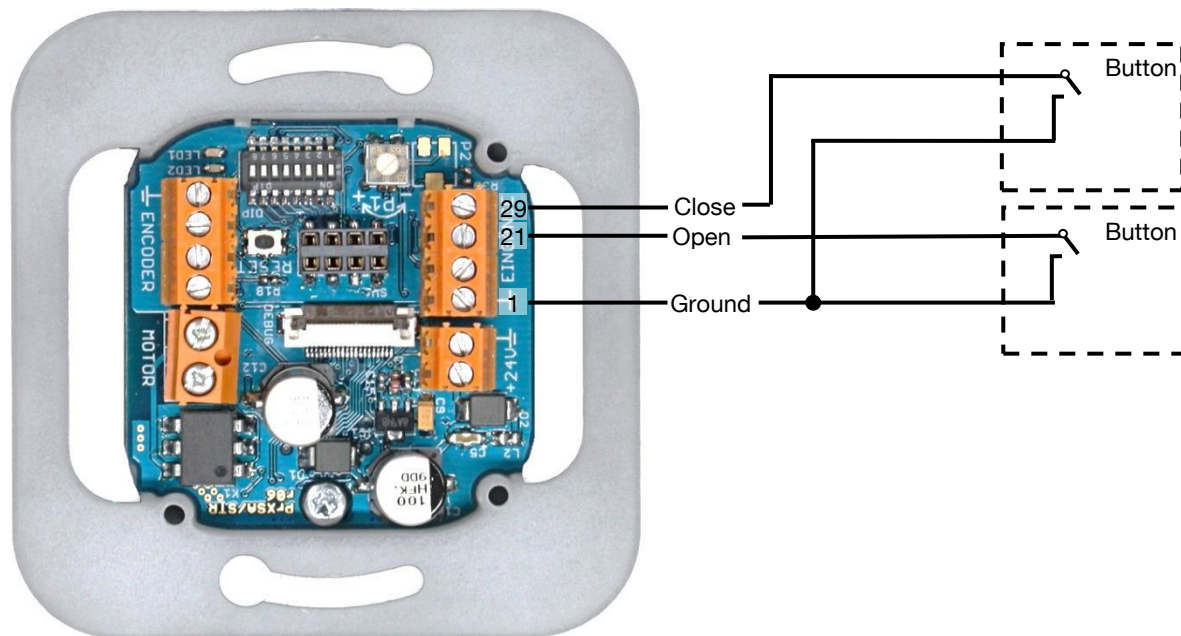

Hint

Operation with one button is only possible in automatic operation mode (Open command). Otherwise two buttons are necessary.

6 Initial operation

After installation of the control device, an initial operation must be performed.

The following sections describe the parts of the control device, which are relevant for the initial operation. The following chapters describe step by step, which functions must be set up and how the initial operation is done.

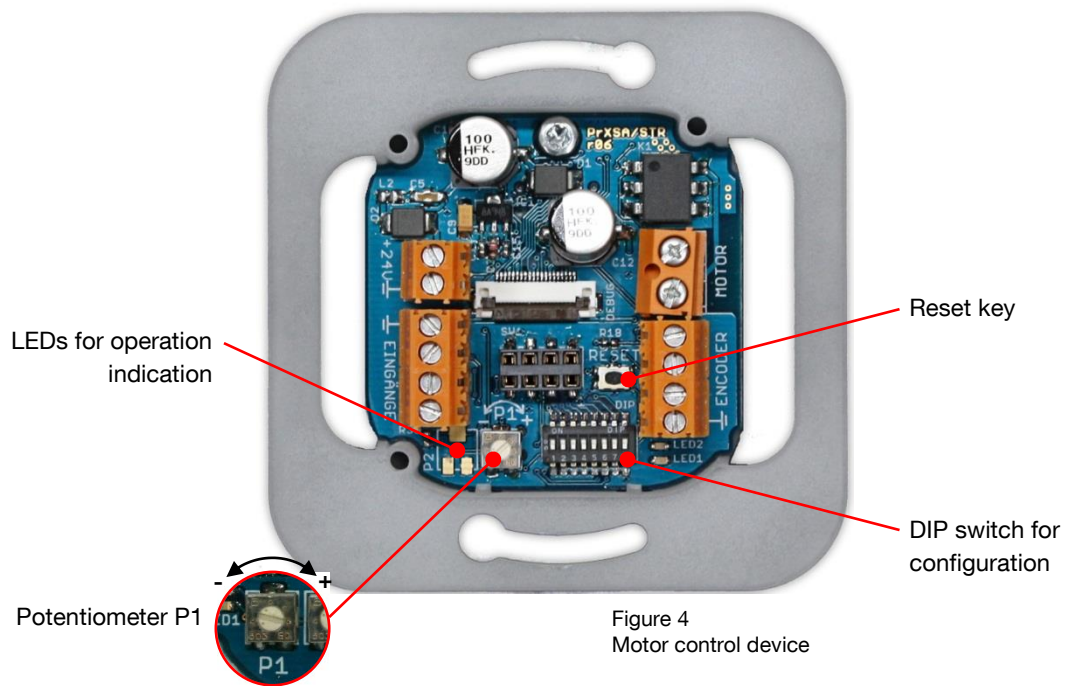

6.1 Configuration

The configuration is set via the potentiometer P1, the DIP switch and the reset button. The function of these elements is described in the following sections.





Hint

Changes in configuration will take effect only when the control device changes into configuration mode and leaves it again.

Set configuration before initial operation

- Set desired parameters, while main power is off.
- Perform initial operation.
 - For details refer to chapter **Fehler! Verweisquelle konnte nicht gefunden werden.**
- ✓ Configuration is set during initial operation.

Set configuration during normal operation

- ✓ Control device is in standby mode. First initial operation has been performed earlier.
- ✓ Power supply is connected, no LED lights up.
- Press RESET key for 2 seconds.
- ✓ Red LED starts blinking continuously. 
- Set up desired configuration.
- Press RESET key for less than 0.5 seconds.
- ✓ Control device is in Startup mode:
 - Red LED flashes twice with a short break of about 1.5 seconds, repeatedly. 
- Trigger an operation to any direction (open or close).
- Drive performs a silent running for reference.
- ✓ Red LED goes out.
- ✓ New configuration is set.

6.1.1 Automatic closing delay time

The automatic closing delay time determines the time the door stays open in automatic operation mode. After the delay time, the door closes automatically.

NOTICE

Over tightened potentiometer

Damage of control device may result in malfunction.

- Potentiometers have a right and a left stop, which must not be over tightened.
 - Adjust potentiometer slightly and with an appropriate tool.
-

Prolong automatic closing delay time

- Turn potentiometer P1 clockwise.
- ✓ After configuration is applied, the door stays open for a longer time.
 - Refer to chapter 6.1

Reduce automatic closing delay time

- Turn potentiometer P1 counter-clockwise.
- ✓ After configuration is applied, the door stays open for a shorter time.
 - Refer to chapter 6.1



Hint

The minimum closing delay time is 5 seconds, the maximum closing delay time is 30 seconds.

6.1.2 Configuration Switch

	Switch	Description	OFF (default)	ON
<p>OFF ↔ ON</p> 	1	Operation mode	Semi-automatic	Automatic
	2	Dead man's control	Disabled	Enabled
	3	Push & Go	Disabled	Enabled
	4	Reaction on obstruction	Reverse	Stop
	5	Closing speed	Reduced speed	Full speed
	6	Weight of door leaf < 80 kg	Disabled	Enabled
	7	Weight of door leaf < 60 kg	Disabled	Enabled
	8	Weight of door leaf < 40 kg	Disabled	Enabled

Table 2 – Configuration switch

1. Operation mode semi-automatic / automatic:
When semi-automatic mode is set the drive will not close automatically. The potentiometer P1 is without function.
When automatic mode is set the drive closes automatically.
2. Dead man's control:
When dead man's control is activated the drive will only operate, as long as an input signal is applied.
Switch 1 is inactive, when dead man's control is selected.
3. Push & Go:
With push & go enabled the drive starts to move, as soon as the door leaf is pushed manually.
4. Reaction on obstruction:
When reverse is set the drive stops and starts to move in the opposite direction, as soon as an obstruction is detected. Otherwise it will stop until a new command is given. (This is only possible in semi-automatic mode).
5. Closing speed:
By default the closing speed is slower than the opening speed. The closing speed can be set as fast as the opening speed, by setting this switch to ON.
6. to 8. Maximum door speed
The maximum speed has to be set via these switches.
Maximum speed is dependent on door leaf weight according to DIN EN 18650.
6: Weight of door leaf up to 80 kg → Maximum speed is 20 cm/s
7: Weight of door leaf up to 60 kg → Maximum speed is 23 cm/s
8: Weight of door leaf up to 40 kg → Maximum speed is 26 cm/s

When no switch is activated, the lowest speed is set (20 cm/s).

When more than one switches are activated, a reduced speed is set (12 cm/s).

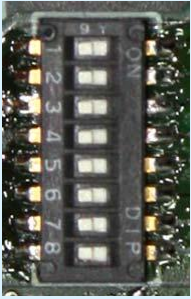
6.2 Steps during initial operation

WARNING



Moving door leaf



Danger of injury by squashing, shearing or collision, caused by moving door leaf.

- Keep area clear during initial operation.

Prepare control device

- Carry out electrical connections.
 - Refer to chapter 5.3
- Set configuration.
 - Refer to chapter 6.1

Perform reset

- Switch power supply on.
- ✓ Control device in delivery status or after power cut:
 - Red LED blinks continuously twice with a short break of 1.5 sec. 
- Press RESET for about 2 seconds.
- ✓ Red LED blinks continuously. 
- Check driving direction of motor with control keys:
 - When pressing OPEN, door has to open and when pressing CLOSE, door has to close.
 - When driving direction is wrong:
 - Swap motor cables (terminals MA and MB), check driving direction again.
- Move door in a middle position by pressing and holding the control keys.
- Press RESET for about 2 seconds.
- ✓ Red LED lights up permanently, green LED lights up during motor activity. 
- ✓ Door moves in the open position, door moves in the closed position, door moves in the open position.
- ✓ LEDs go out.

Check functionality

- Test, if door shows desired behavior.
- In case of malfunction check electrical connections and configuration.
 - For electrical connection refer to chapter 5.3
 - For configuration refer to chapter 6.1
 - Repeat initial operation, if necessary.
- ✓ Initial operation is completed, when function is correct.

6.3 Behavior after a power cut

When the main power is cut off, the control device will not work. The control device can be operated without an initial operation, when main power is restored (Provided that the control device has already been put into operation).

Bring control device back into normal operation

- Restore main power.
- ✓ Control device after power cut:
Red LED blinks continuously twice with a short break of 1.5 sec.
- Execute desired action:
Press OPEN to open the door, press CLOSE to close the door.
- ✓ First movement will start with reduced speed.
- ✓ Normal operation is restored.



Hint

After a power cut, no further initial operation is necessary. The operation parameters are saved permanently during initial operation.

6.4 Error mode

If an error is encountered during or after initial operation, the control device changes into error mode. The error code is displayed by a blinking code. In this mode it is not possible to move the door leaf.

Name	Description	Code
Unknown error	An unknown error occurred.	1
Self-test – Several errors	The self-test detected several problems.	2
Self-test – Oscillator defective	The self-test detected a defective main oscillator.	4
Self-test – Motor relay defective	The self-test detected a defective motor relay.	5
Self-test – Motor driver defective	The self-test detected a defect in the motor driver.	6
Self-test – Current measurement defective	The current measurement is not working properly.	7
Self-test – Motor driver fault detection defective	The motor driver fault detection is not working properly.	8
Hardware – Encoder error	The encoder is defective or not connected properly.	9
Hardware – Supply voltage out of range	The supply voltage is out of its operation range.	10
Memory – RAM defective	A memory defect was detected in the RAM.	11
Memory – ROM defective	A memory defect was detected in the ROM or the program code was altered intentionally.	12
Memory – EEPROM defective	The parameter memory is defective.	13

Table 3 – Error codes

The red and green LEDs display the error code by blinking in a special way:

First, the red LED blinks fast, then it lights up permanently for 20 seconds. The green LED blinks as many times, as the error code which it displays. This cycle repeats every 24 seconds until the error is reset.

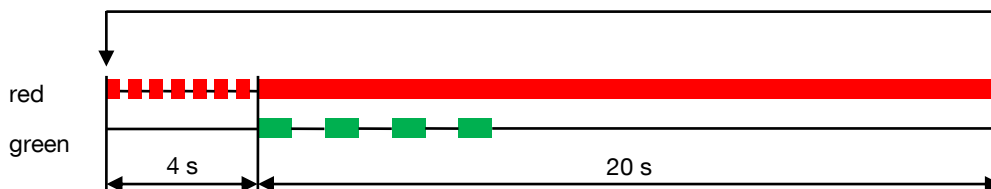

In this example, the error code 4 is shown (Self-test - Oscillator error).

7 Wireless receiver

For wireless operation of the control device, a wireless receiver is available in two different variants: Wireless receiver with additional manual keys or wireless receiver without keys. The receiver replaces the standard key cover of the control device. No additional connections are required.

7.1 Mounting of wireless receiver

Mounting of receiver

The mounting of the wireless receiver is equal to the mounting of the standard key cover. (Refer to chapter 5.2)

- Mount control device in flush box (Refer to chapter 5.2).
- Place cover over control device.
- Plug wireless receiver through cover into control device.
- ✓ Wireless receiver is mounted.

7.2 Programming of wireless receiver

To teach-in hand transmitters, access to the LEARN button is needed. Therefore the cover of the wireless receiver must be removed.

Preparation of receiver

- Remove front cover of receiver.
- Have your hand transmitter ready.
- Place cover over receiver, when programming is done.

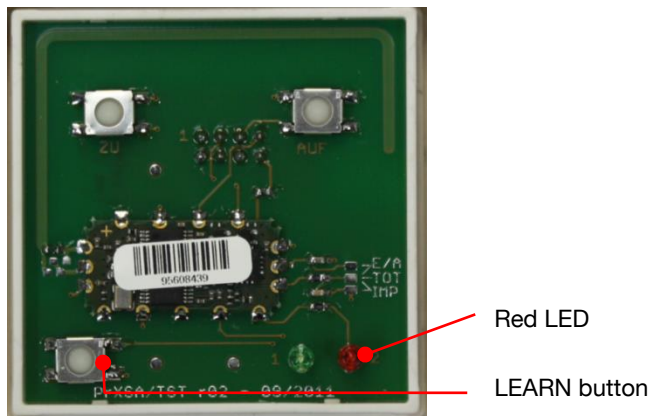

Figure 4 – Wireless receiver



Hint

The wireless receiver overrides the red LED of the control device. For an easier teach in, the control device should have performed an initial operation and be in standby mode.

7.2.1 Teach-in of hand transmitters

Teach-in of a hand transmitter

- Press LEARN button for less than 1 second.
- ✓ Red LED blinks slowly.
- Press any key of hand transmitter.
- ✓ Red LED lights up for about 4 seconds and continues blinking then.
- ✓ Hand transmitter is teached.
 - If applicable, repeat procedure for further hand transmitters.
- Press LEARN button, when finished.
- ✓ Red LED goes out.

Teach-in of further hand transmitters

The teach-in of further hand transmitters goes analogue to the teach-in of the first hand transmitter. Teached-in transmitters stay teached, until they are deleted.

7.2.2 Delete registered hand transmitters

Deleting a registered hand transmitter

- Press LEARN button for more than 2 seconds.
- ✓ Red LED blinks fast.
- Press any key of the hand transmitter.
- ✓ Red LED lights up for about 4 seconds and continues blinking then.
- ✓ Hand transmitter is deleted.
 - If applicable, repeat procedure for further hand transmitters.
- Press LEARN button, when finished.
- ✓ Red LED goes out.

Deleting all registered hand transmitters

- Press LEARN button for more than 2 seconds.
- ✓ Red LED blinks fast.
- Press LEARN button for more than 2 seconds.
- ✓ Red LED lights up for about 4 seconds.
- ✓ Red LED goes out.
- ✓ All hand transmitters are deleted.