

EVOLVE POCKET DOOR PRO

Fitting Instructions

ABOUT THIS DOCUMENT

This document addresses qualified personnel only. The mounting must be done by technically educated, trained and qualified personnel. Electrical wirings have to be completed by suitably qualified specialists.

These instructions describe how to install the track and sliding door hardware. For installation of the drive motor, switches or sensors - please refer to the operating instructions for the Evolve Motor and Wiring Instructions.

The manufacturer's specification must be respected in especially maximum weight restriction of door leaf. Any other use of this product is considered inappropriate use.

It is not guaranteed that this product will work in conjunction with fittings, motors or other electronic devices supplied by other manufacturers.

The appliance is only to be used with the power supply unit provided.

Before you commence work, please read through these instructions. Please store these instructions in a safe place and pass them on to any future owners. Damage resulting from non-compliance with these instructions and safety instructions will void the warranty. PC Henderson nor the motor unit manufacturer will assume liability for any consequential damage.

KIT AND DOOR SPECIFICATION

Kit Short Code	Max. Door Height	Max. Door Width	Door Thickness Range	Max. Door Weight
EVOPRO1/***	1981mm (78")	610mm (24")	35 – 45mm	80kg
EVOPRO2/***	1981mm (78")	686mm (27")	35 – 45mm	80kg
EVOPRO3/***	1981mm (78")	762mm (30")	35 – 45mm	80kg
EVOPRO4/***	1981mm (78")	838mm (33")	35 – 45mm	80kg
EVOPRO6/***	2040mm (80")	826mm (32.5")	35 – 45mm	80kg
EVOPRO7/***	2040mm (80")	726mm (28.5")	35 – 45mm	80kg
EVOPRO10/***	2315mm (91")	930mm (36.5")	35 – 45mm	80kg

*** For full short code replace with required finished wall thickness size – 120 or 125 (mm)

Note: If installing a liner kit with this kit please refer to Pocket Door Pro Liner Kit fitting instructions – this should be installed last.

ELECTRICAL COMPONENTS

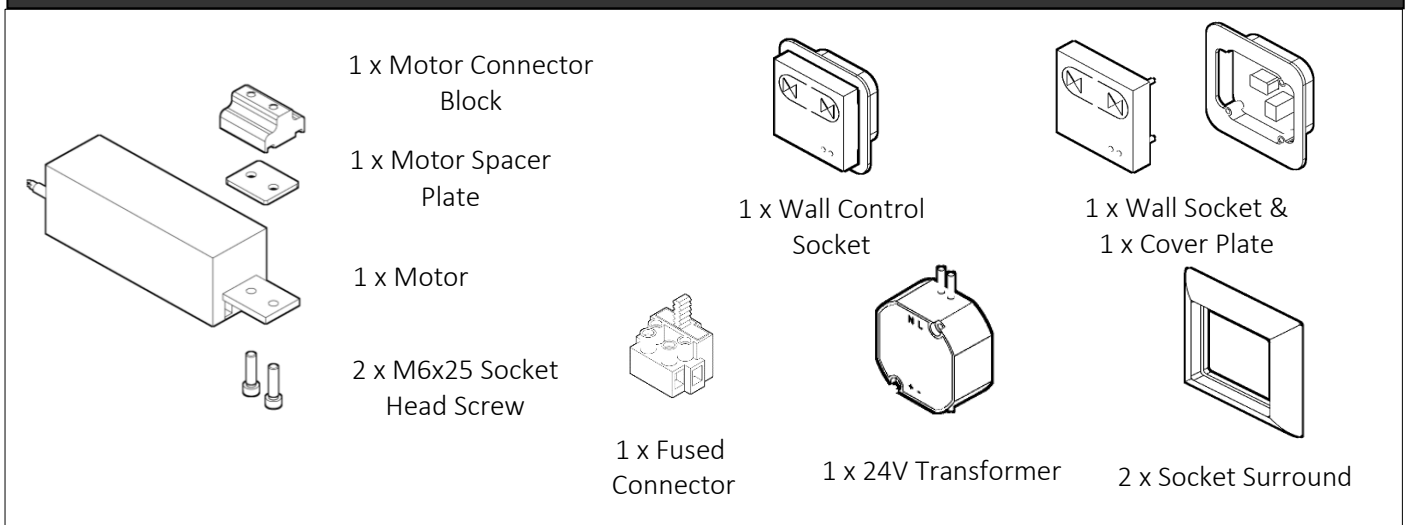

KIT CONTENTS

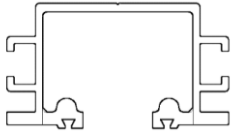

1 x Header Track



2 x Hangers

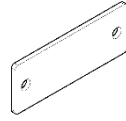

4 x 2.5mm spacer plate
125mm finished wall thickness
version only



(Upright profile)



4 x Fixing Plates



1 x SS Belt Clamp



1 x Clamp and Pulley
Wheel

2 x Left Hand
Upright Assembly

2 x Right Hand
Upright Assembly



Noggin

2 x 395mm in EVOPRO1 & 2
2 x 545mm in EVOPRO3, 4, 6, 7
4 X 545mm in EVOPRO10
4 X 295mm EVOPRO10

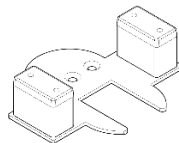

Floor/Wall Bracket

2 x in EVOPRO1, 2, 3, 4, 6, 7
4 x in EVOPRO10

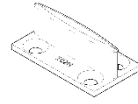

Floor
Guide
102N

2 x Double
Upright Assembly
(EVOPRO10 only)



8 x Screw A
M6x20 Cap Head
Screws



Screw B
4.2 x 25 Self tapping
8 x in EVOPRO 1, 2, 3, 4, 6, 7
24 x in EVOPRO10



Screw c
No 8 x 1" Woodscrew
18 x in EVOPRO 1-7
24 x in EVOPRO 10



1 x Toothed Belt Length

TOOLS REQUIRED



Drill
With magnetic posi head driver

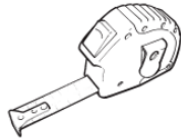

Tape Measure



5mm Allen Key

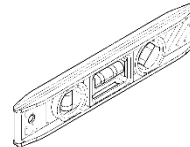

Spirit Level

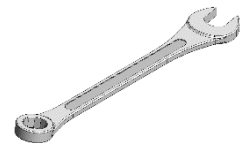

6mm & 13mm Spanner

Evolve Wiring Diagram

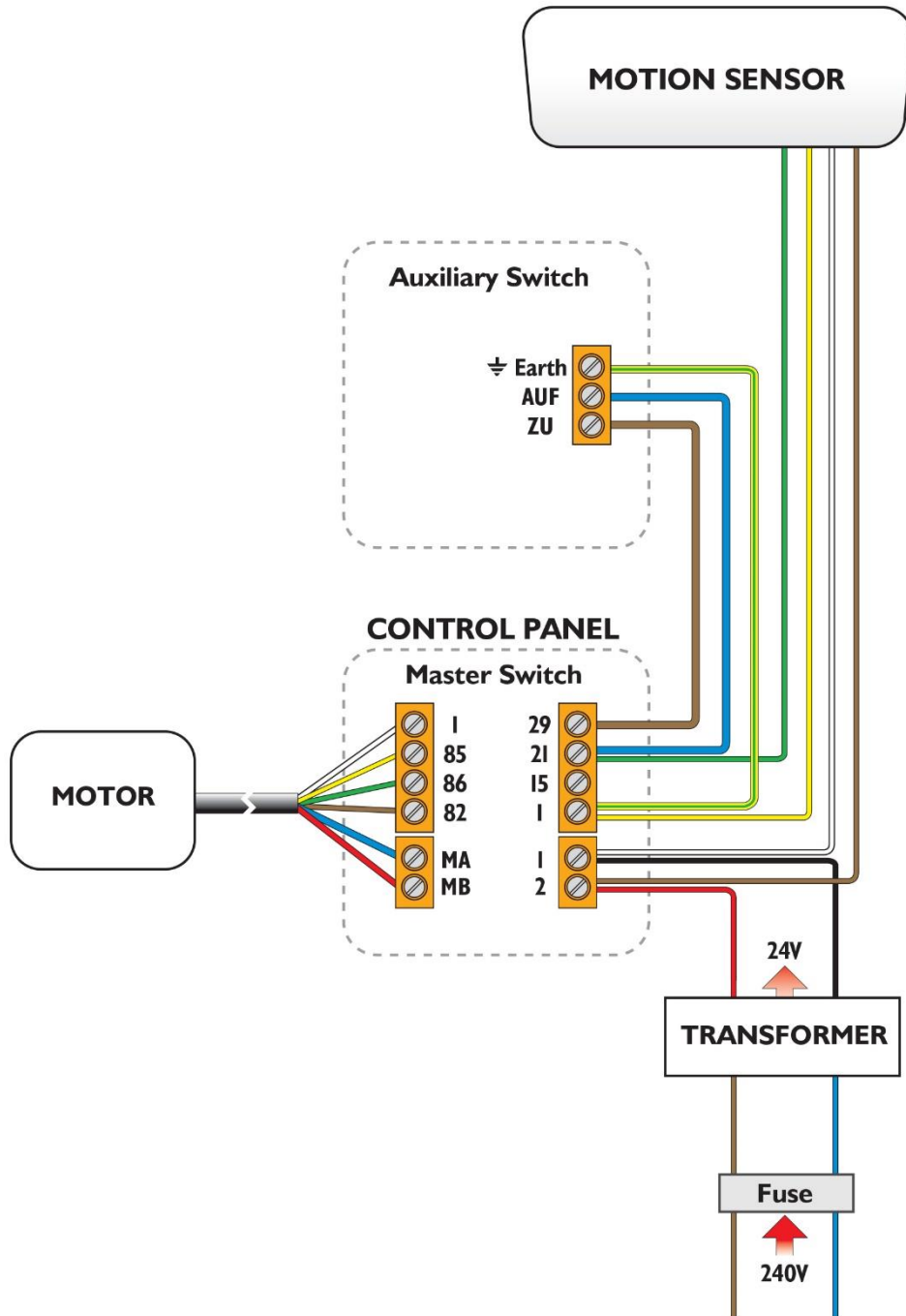

WIRING DIAGRAM OVERVIEW

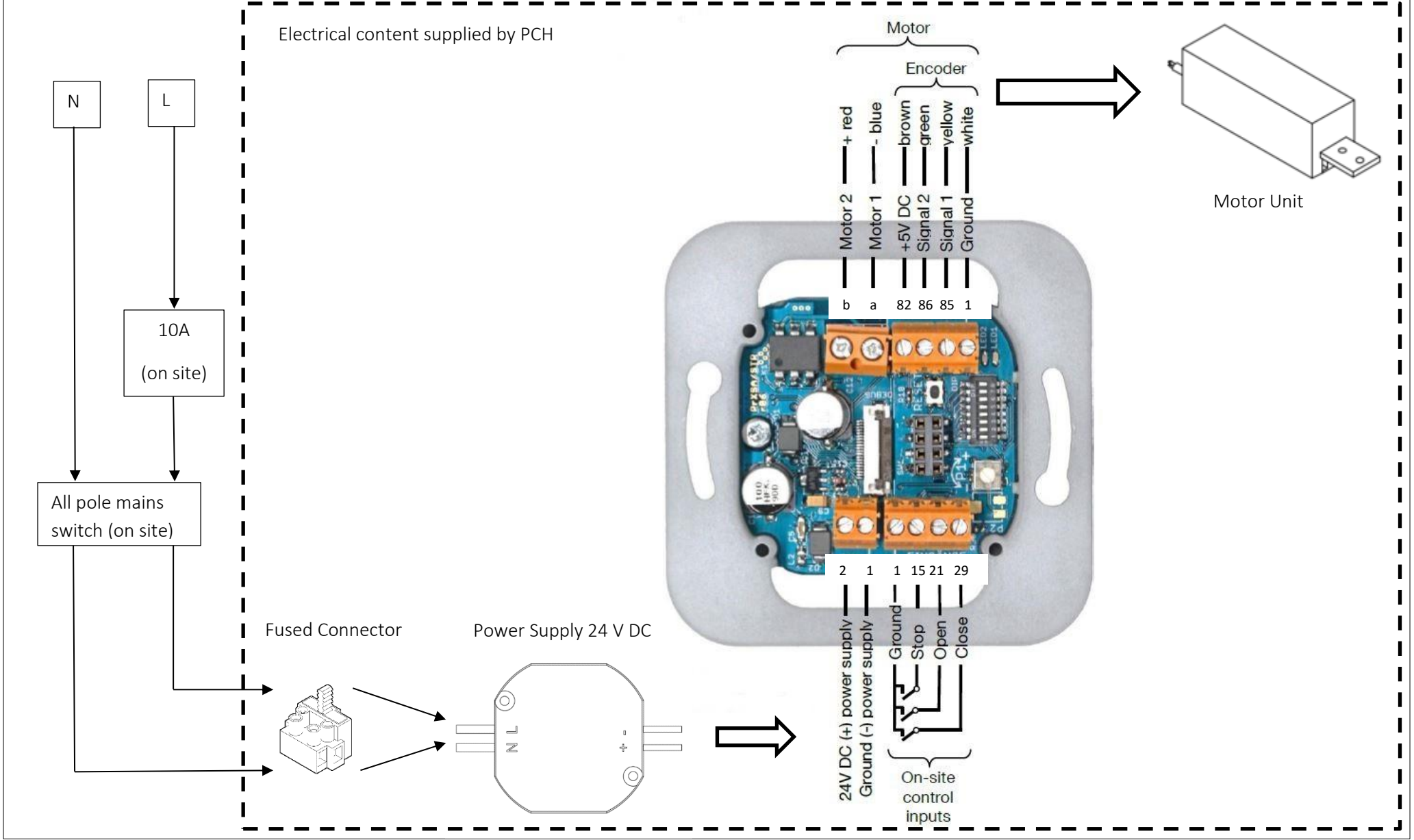

WIRING WALL MOUNTED SOCKET - OVERVIEW

For detailed operation and programming instructions please consult separate Evolve Motor and Wiring Instructions supplied.

1. Operation Mode Semi-Automatic/Automatic

When semi-automatic mode is set the drive will not close automatically - the potentiometer is without function. When the automatic mode is set the drive closes automatically.

2. Dead Man's Control

When dead man's control is activated the drive will lonely operate, as long as an input is applied. Switch 1 is inactive when dead man's control is selected.

3. Push & Go

With push & go enabled the drive starts to move, as soon as the door is pushed manually.

4. Reaction on Obstruction

When reverse is set the drive stops and starts to move in the opposite direction as soon as an obstruction is detected. If this isn't set it will stop until a new command is given. This is only possible in semi-automatic mode.

5. Closing Speed

By default the closing speed is slower than the opening speed. The closing speed can be set as fast as the opening speed, by setting this switch to ON>

6. Maximum Door Speed

The maximum speed has to be set via these switches

Maximum speed is dependent on the door weight according to DIN EN 18650

- Weight of door is up to 80kg - maximum speed is 20cm/s
- Weight of door is up to 80kg - maximum speed is 23cm/s
- Weight of door IS up to 80kg - maximum speed is 26cm/s

When no switch is activated, the slowest speed is set (20cm/s)

When more than one switch is activated, a reduced speed is set (12 cm/s)

PERFORM RESET

1. Switch Power Supply On

- Control device in delivery status or after power cut
- Red LED blinks continuously twice with a short break of 1.5sec



2. Press RESET for About 2 Seconds

- Red LED blinks continuously

3. Check Driving Direction of Motor with Control Keys

- When pressing OPEN, door has to open and when pressing CLOSE, door has to close
- When driving direction is wrong - swap motor cables (terminals MA and MB), check driving direction again.

4. Move Door in Middle Position by Pressing and Holding the Control Keys



5. Press RESET for About 2 Seconds

- Red LED lights up permanently
- Green LED lights up during motor activity
- Door moves in the open position
- Door moves in the closed position
- Door moves in the open position
- LED's go out



CHECK FUNCTIONALITY

1. Test, if the door shows desired behavior
2. In case of malfunction check electrical connections and configurations
 - for electrical connection refer to chapter 5.3 of the Evolve Motor and Wiring Instructions supplied
 - for configuration refer to chapter 6.1 of the Evolve Motor and Wiring Instructions supplied
 - Repeat initial operation, if necessary
3. Initial operation is completed when function is correct

EVOLVE POCKET DOOR PRO KIT CONFIGURATION

EVO PRO 1, 2, 3, 4, 6 & 7

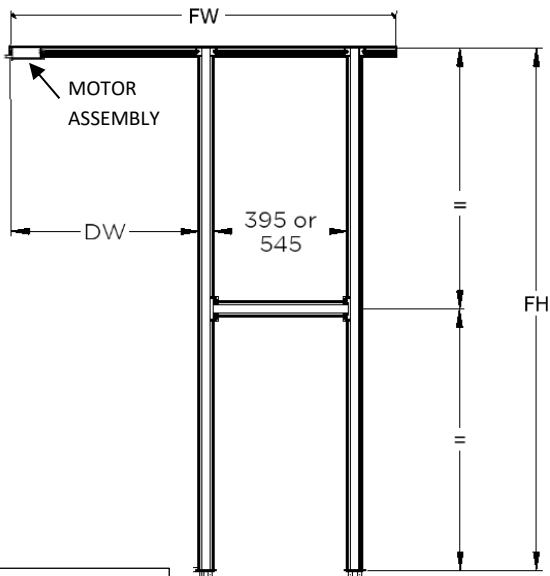

NOTE
 DW = door width
 FW = frame width
 FH = frame height

EVO PRO 10

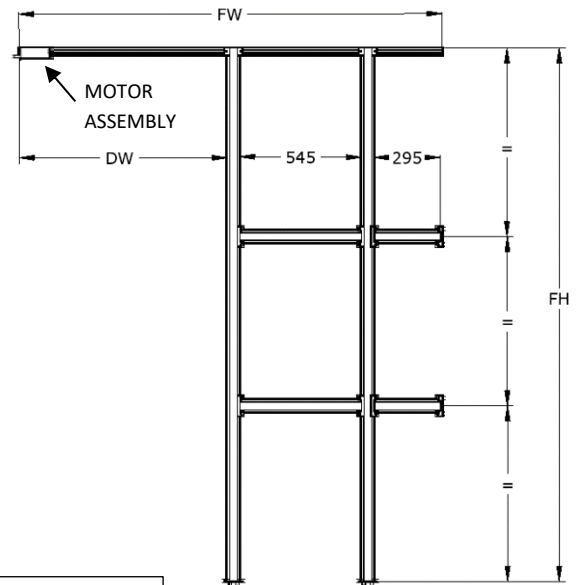

NOTE
 DW = door width
 FW = frame width
 FH = frame height

EVOLVE POCKET DOOR PRO HEADER & FOOTER DETAIL

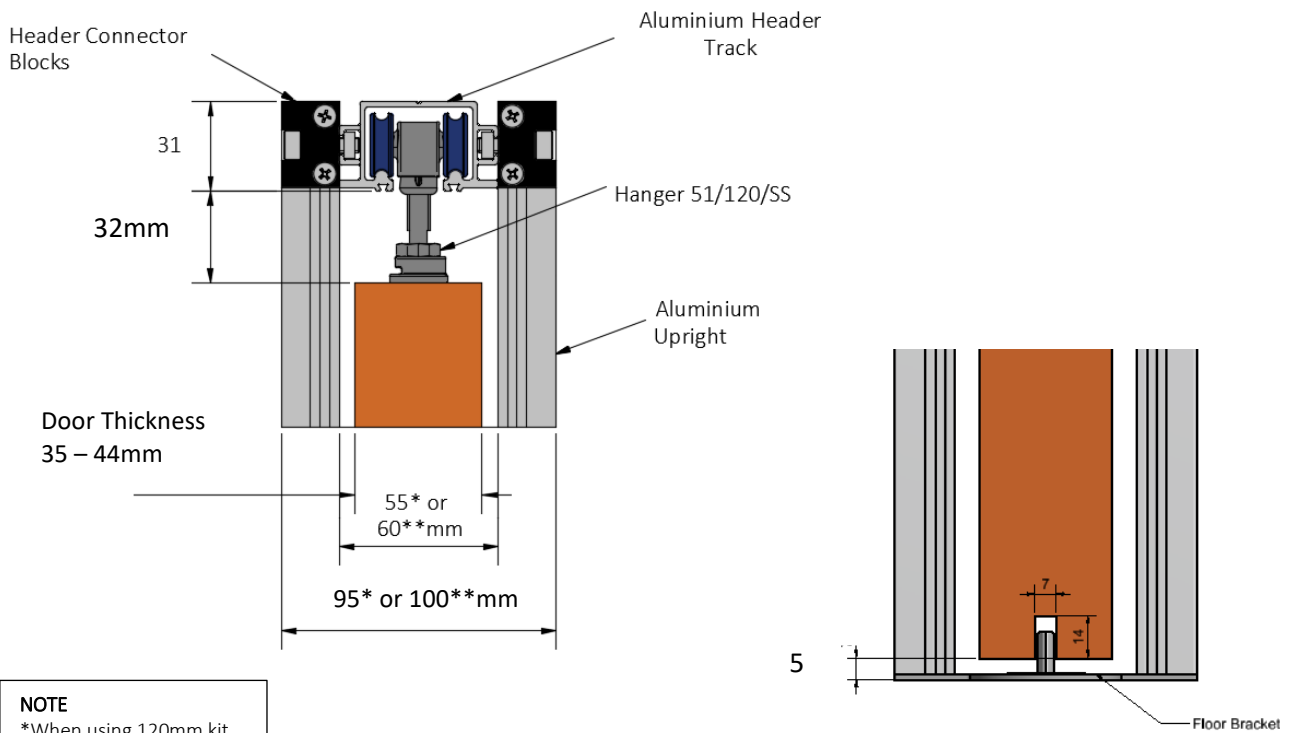

NOTE
 *When using 120mm kit
 ** When using 125mm kit

STEP BY STEP INSTRUCTIONS

STEP 1: Prepare the rough opening

How to calculate the opening width required

- Opening width in mm = (door width x 2) + 30mm (or 62mm if using with self-closing mechanism)
- Opening height in mm = door height + 70mm

Note: 70mm allows for: door floor clearance (range 7 - 20mm) + top of door to bottom of track (range 19 - 32mm) + track height (31mm)

Finished Wall Thickness

Stud wall can be 95mm or 100mm plus plasterboard (2 x 12.5mm) e.g.

95mm cavity + 12.5mm plasterboard either side = 120mm finished wall thickness

100mm cavity + 12.5mm plasterboard either side = 125mm finished wall thickness

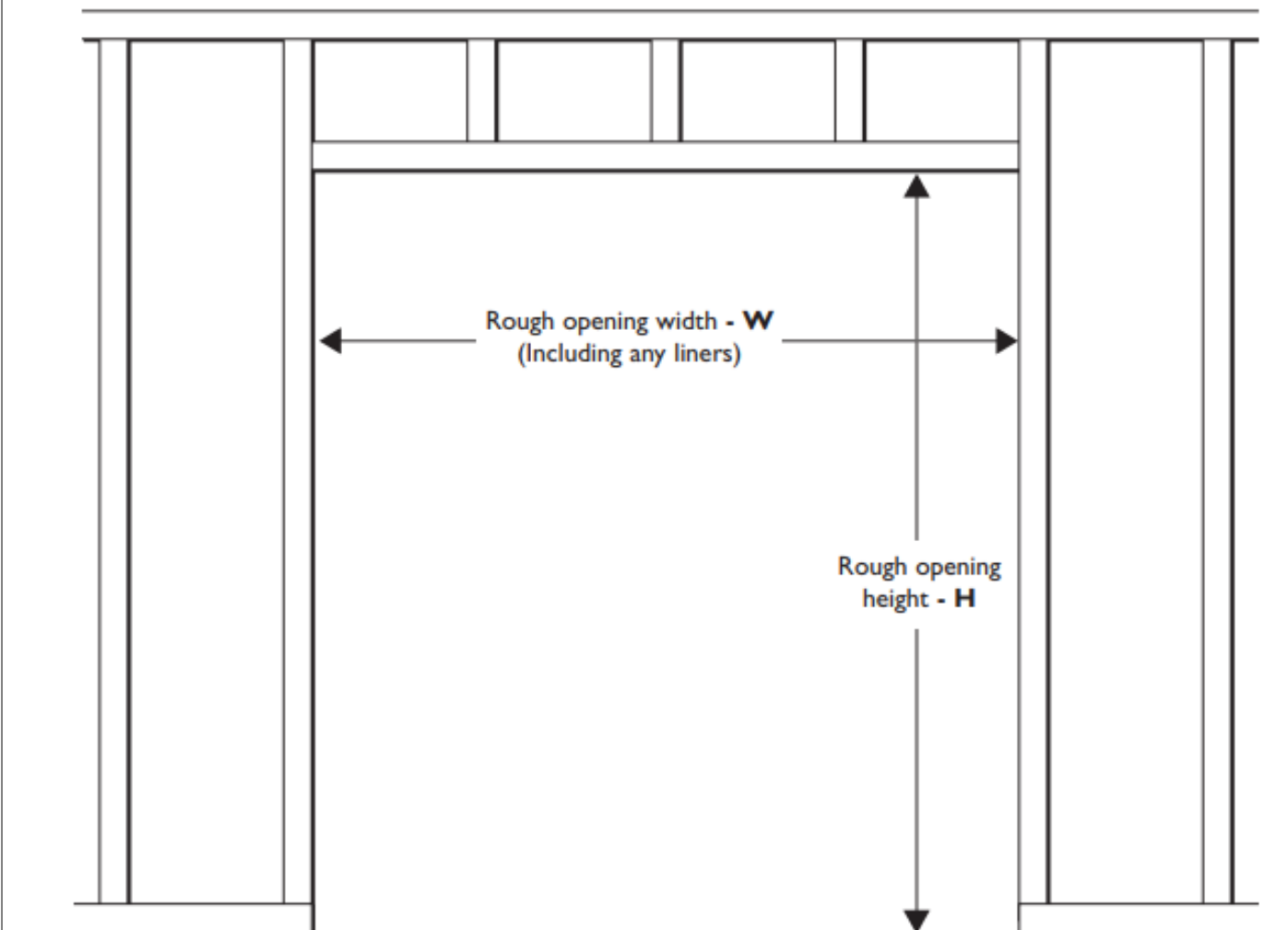

STEP 2: Insert fixing plates into side wings of track

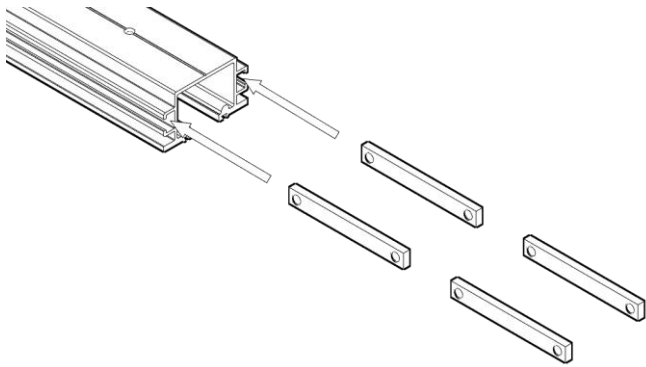

STEP 3: Using suitable fixings (not PCH) position header in soffit location (see page 6 for positioning detail)

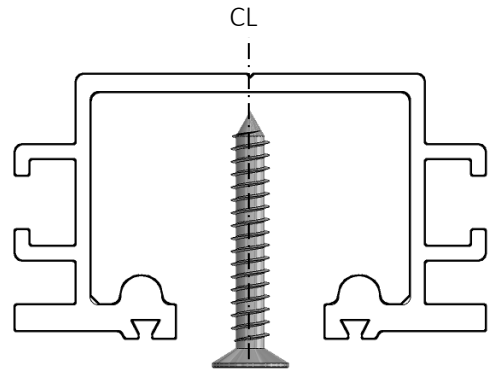

NOTE: Ensure the cut out side is adjacent to the jamb.

STEP 4: Position the floor bracket on the ground so it is roughly in line with the center of header track

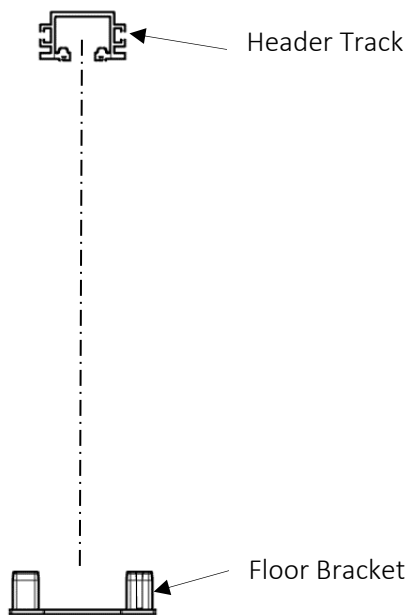

STEP 5: Locate assembled upright on to floor guide – using screw C (see page 6 for positioning detail)

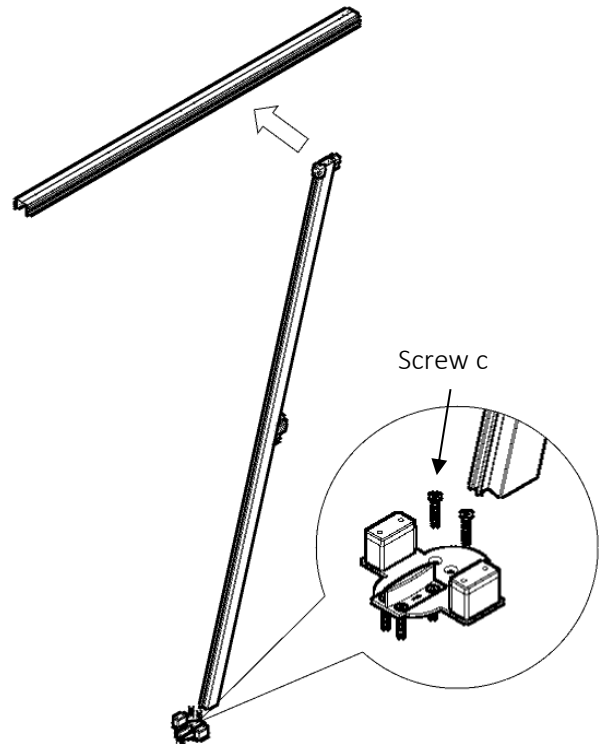

STEP 6: Affix upright to header track using fixing plates and screw A (see page 6 for positioning detail)

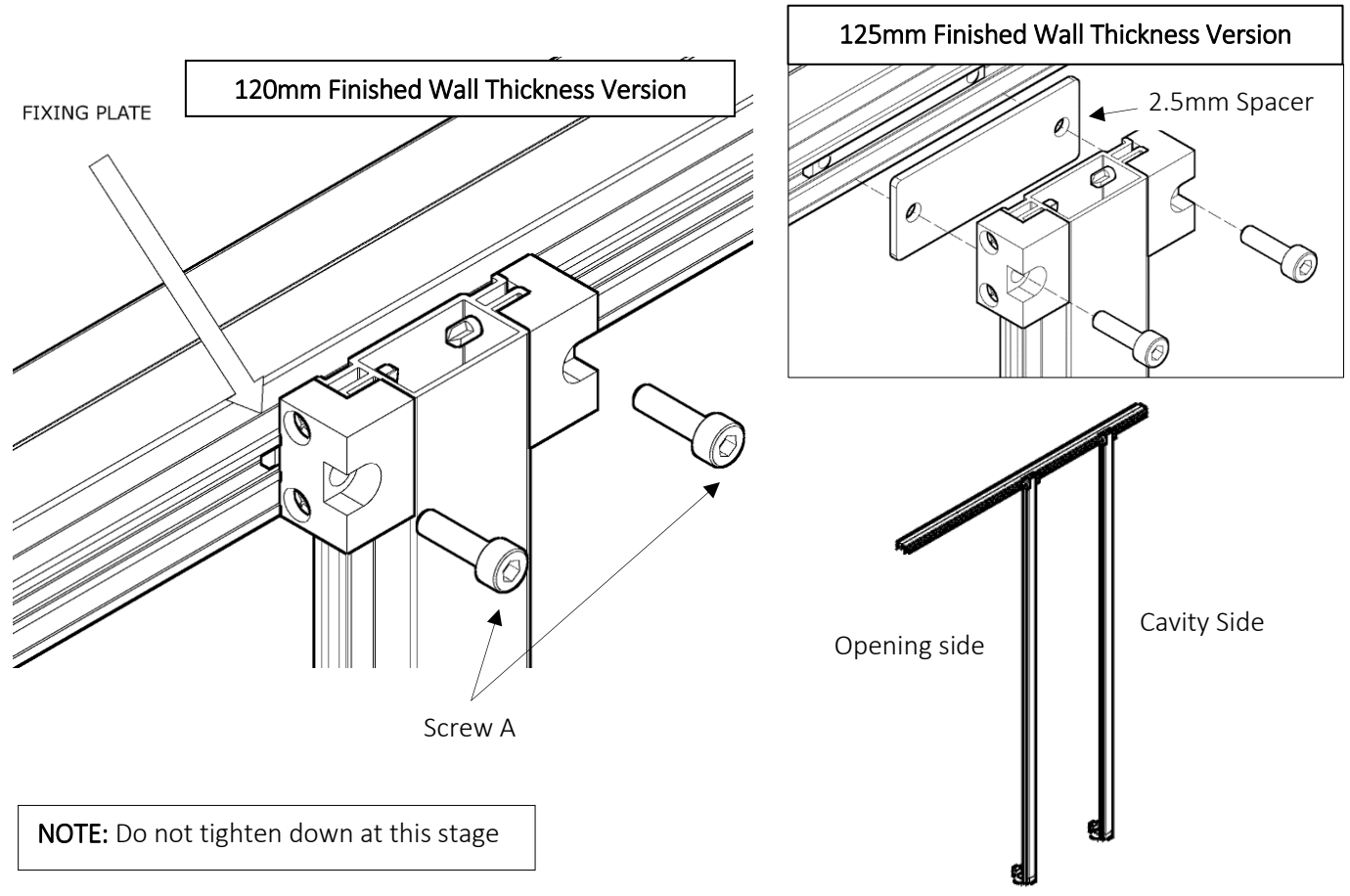

STEP 7: Position noggin onto pre-assembled plastic spacers

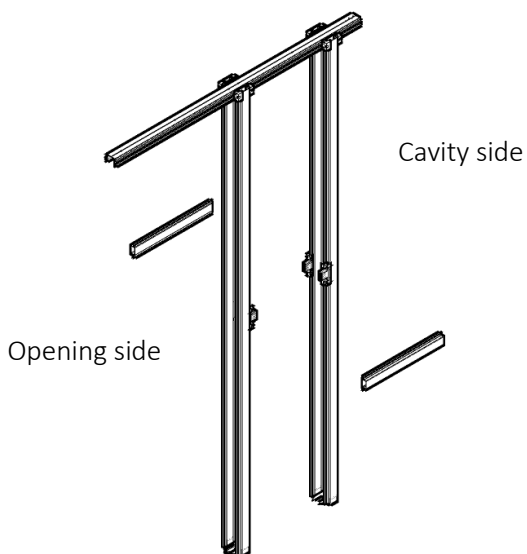

STEP 8: Place second upright onto noggin to set width

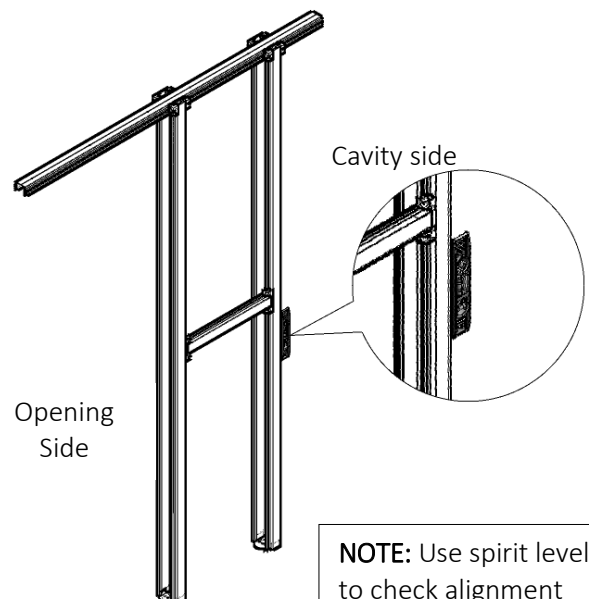

STEP 9: Affix floor brackets to floor, ensuring correct alignment using spirit level (using screw C). Secure noggins into place using screw B. Fit 102N guide. (See page 6 for positioning detail)

NOTE: Use spirit level to check alignment

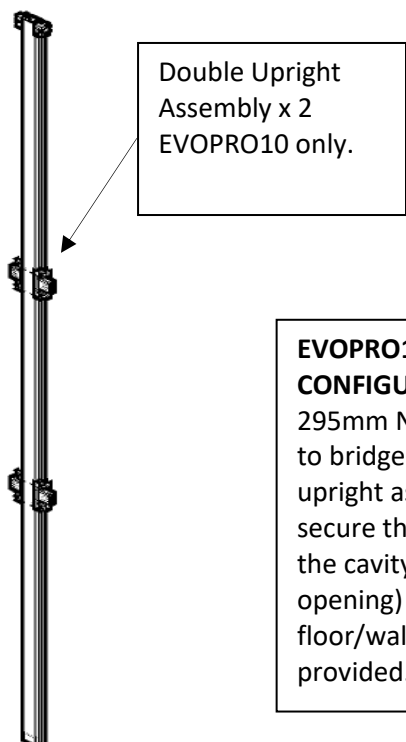
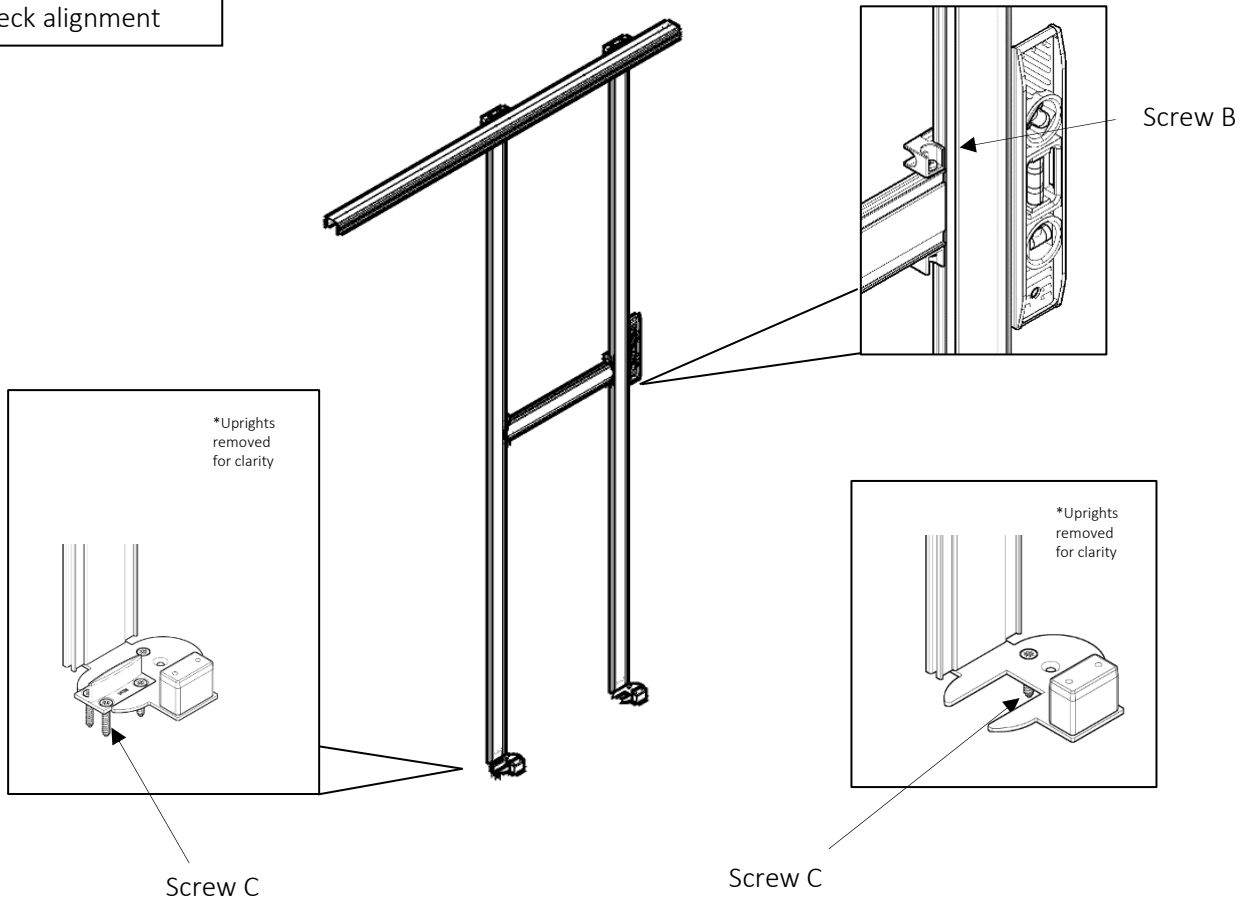

EVOPRO10 CONFIGURATION
295mm Noggins are used to bridge the double upright assemblies and secure them to the end of the cavity (rough opening) with the floor/wall brackets provided.

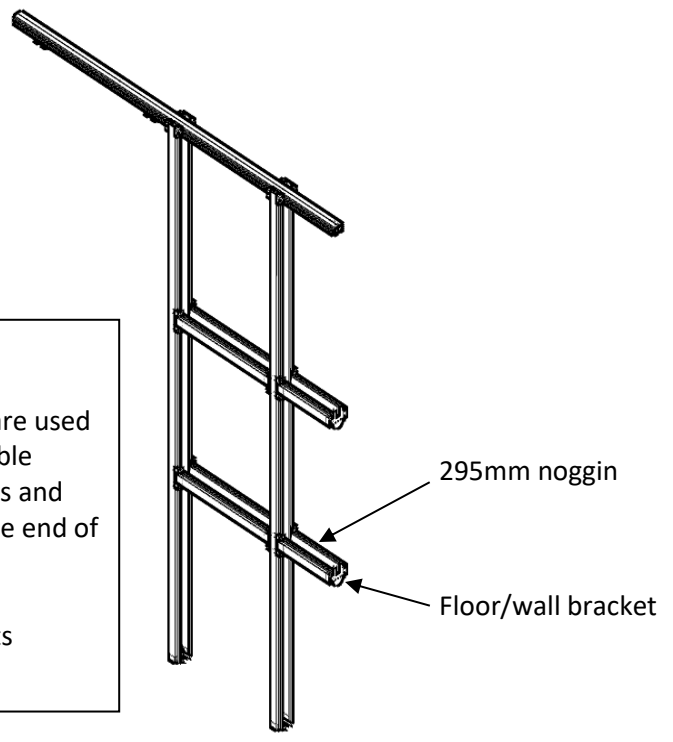

STEP 10: Insert hangers and door stop into track, in order shown.

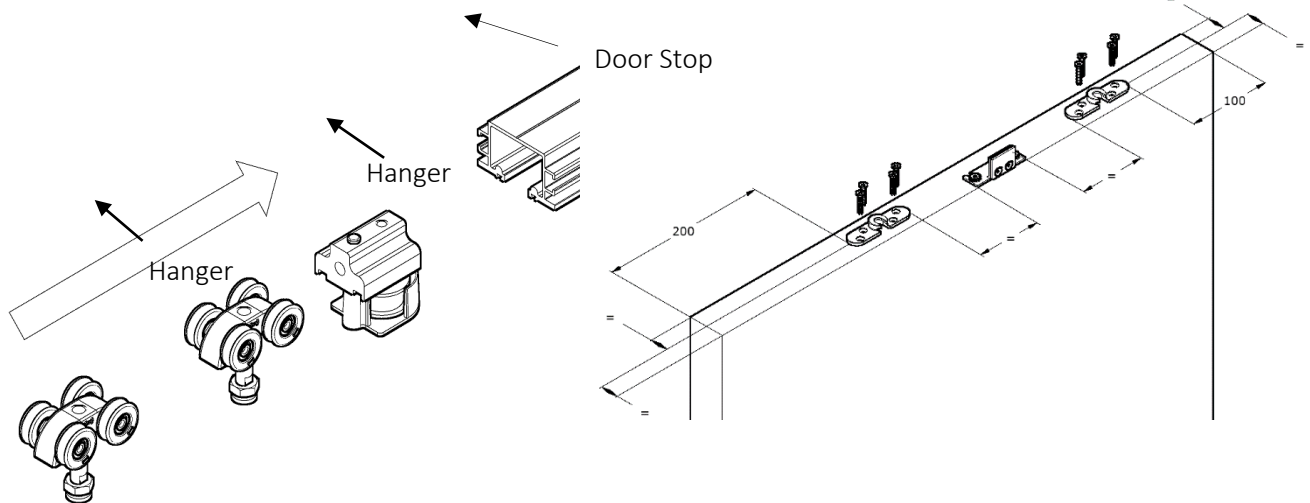

STEP 11: Attach motor unit to track using screw C

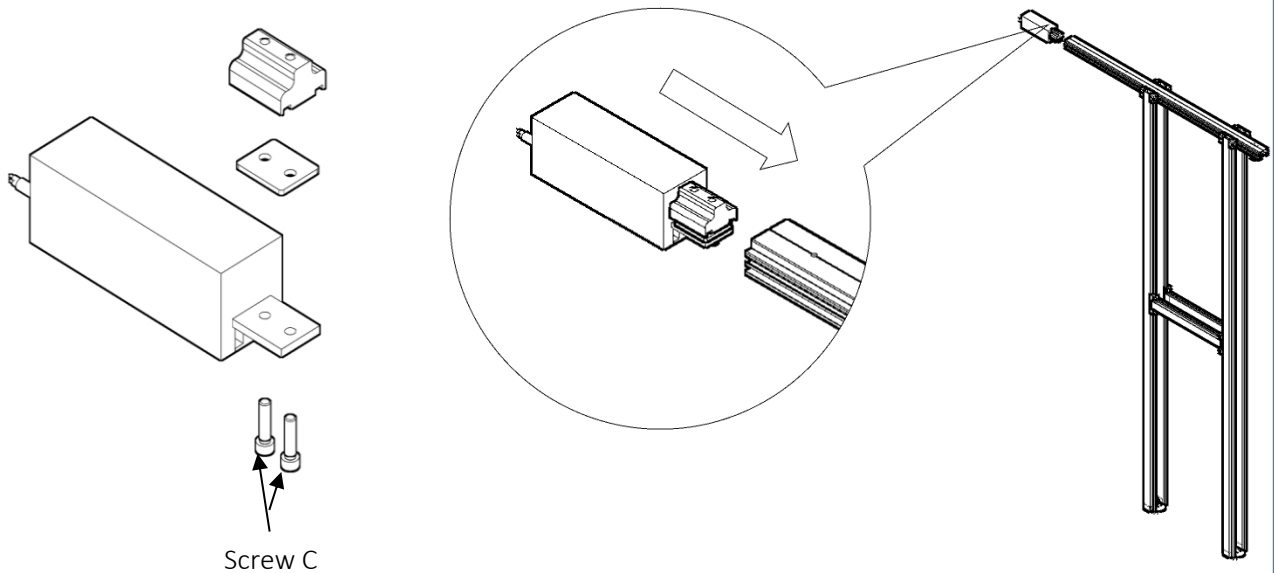

STEP 12: Hang the door – attach door to hangers and secure lock nut using 6 and 13mm spanner

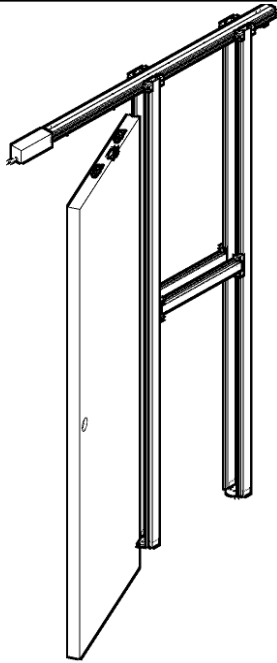

Distance between
bottom of track and
top of door = 32 mm

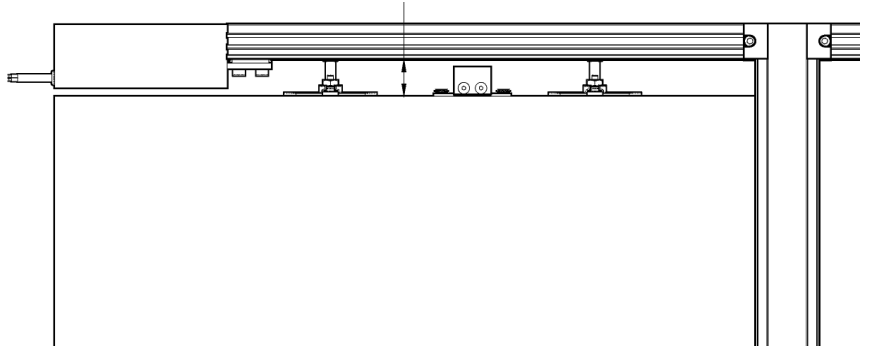

STEP 13: Secure door using lock nut with a 6mm and 13mm spanners

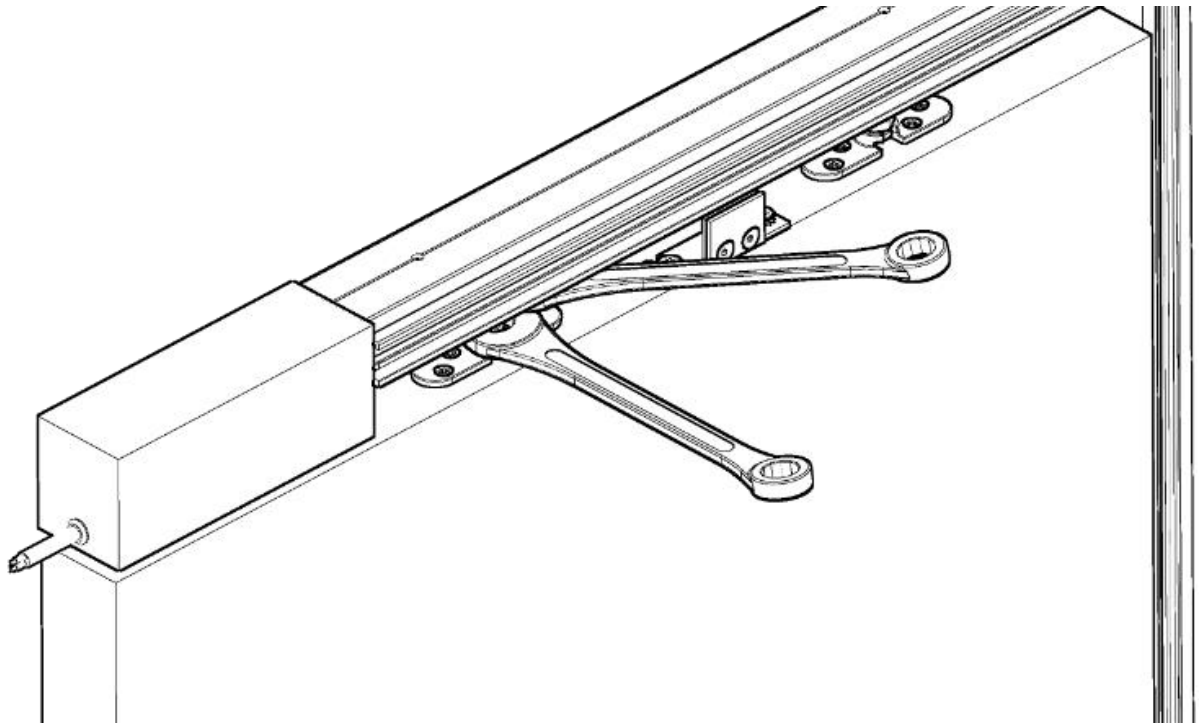

ATTACHING BELT TO SYSTEM

STEP 14: Remove caps from motor unit and belt tension wheel

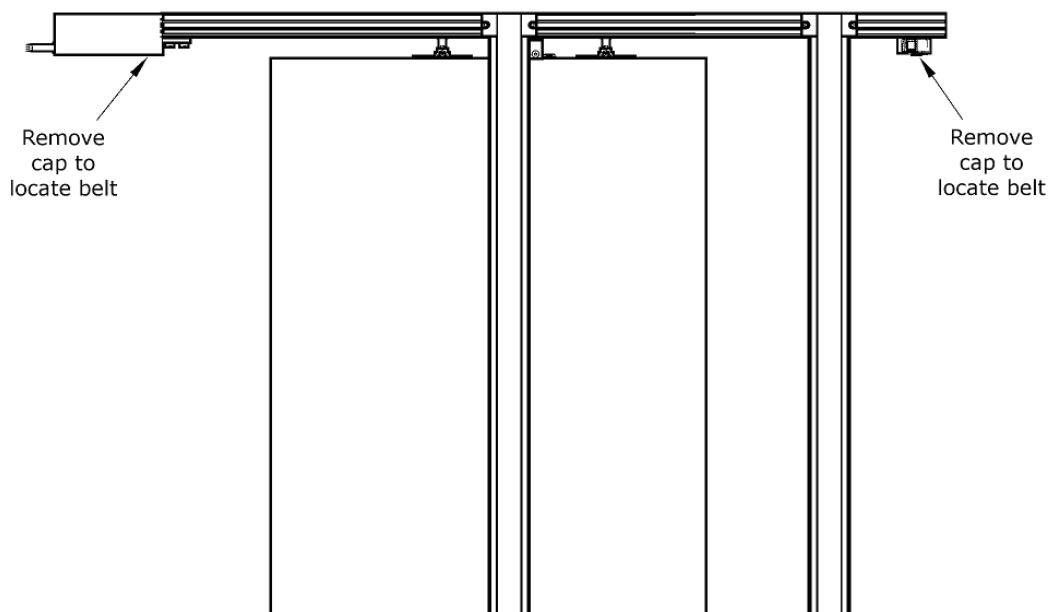

STEP 15: Wrap belt around both wheels and attach open ends of belt to belt clamp at top of door

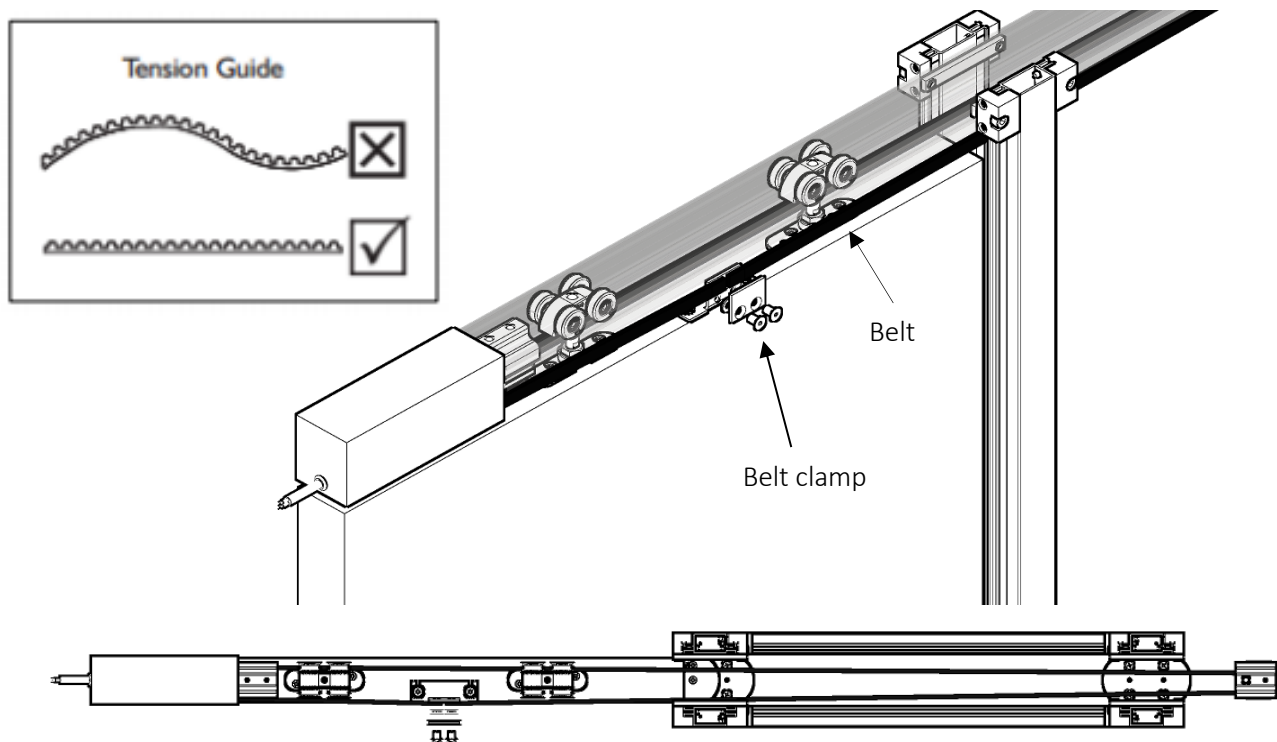

STEP 16: Ensure belt is adequately held by belt clamp and check belt tension (to reduce belt sag as much as possible) then reattach caps

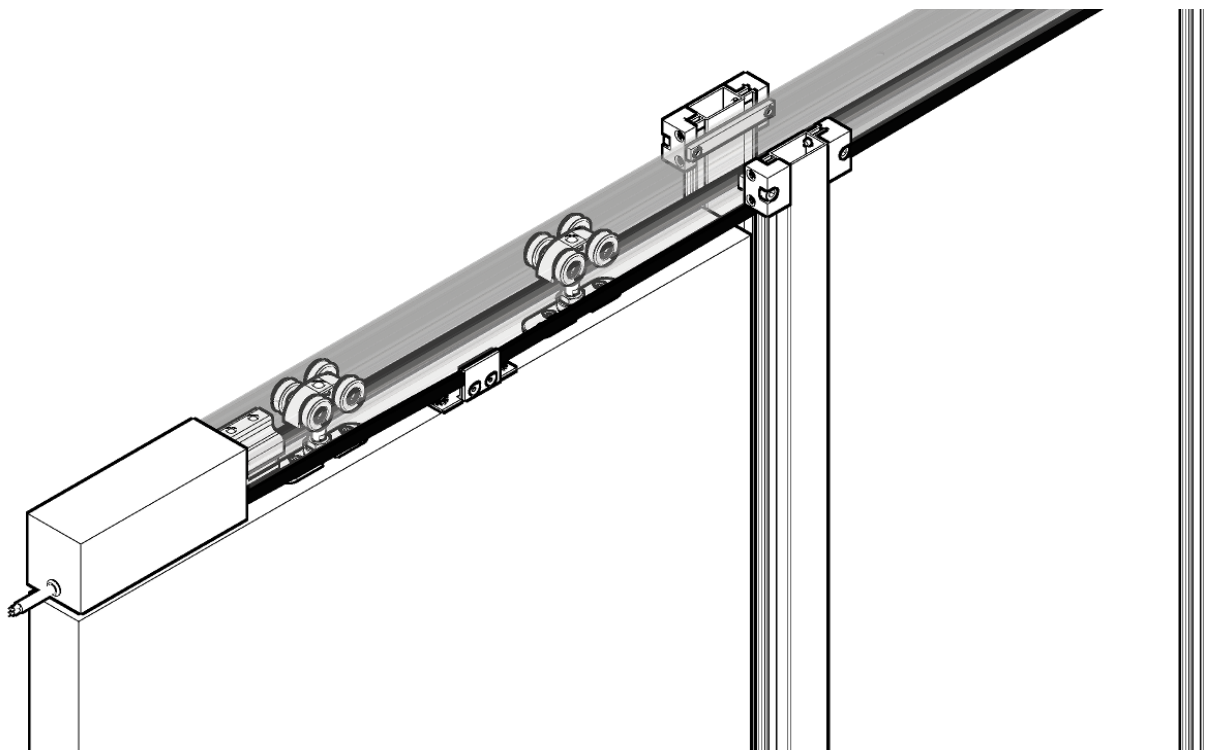

STEP 17: Manually move door up to both stops to check door travel before undergoing programming sequence

1.

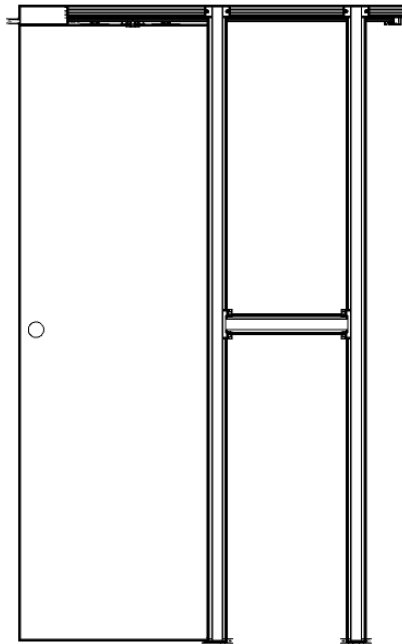

General Safety Precautions

- This installation is intended for professionally competent personnel only.
- Installation, electrical connections and adjustments must be performed in accordance with good working methods and in compliance with applicable regulations. Before installing the product, carefully read the instructions. Bad installation could be hazardous.
- The packaging material (plastic, polystyrene, etc.) should not be discarded in the environment or left with reach of children, as these are a potential source of hazard.
- Before installing the product, make sure it is in perfect condition.
- Do not install the product in an explosive environment and atmosphere; gas or inflammable fumes are a serious risk hazard. Before installing the system, ensure all structural changes relating to safety clearances and protection or segregation of all areas where there is a risk of being crushed, cut or dragged, and danger areas in general.
- Make sure the existing structure is up to standard in terms of the motorised door.
- Apply hazard area notices required by application regulations.
- The electricity supply must be isolated at its source before attempting installation or maintenance.

Disclaimer

P C Henderson, nor the motor unit manufacturer, take any responsibility for failure to use good working methods in building the frames to be motorised or for any deformation occurring during use. P C Henderson and the motor unit manufacturer declines all responsibility in the event of component parts being fitted that are not compatible with safe and correct operation.

For repairs or replacement of products - only original spare parts must be used.

Installer Responsibility

The installer should provide technical documentation once the installation is complete.

- EC declaration of conformity with machinery directive
- Installation manual
- Maintenance / Trouble shooting guide (supplied in the drive unit manufacturer operation manual)
- The installer is responsible for affixing final CE mark upon the installation

Manufacturer's Declaration of Incorporation

Manufacturer: PC Henderson, Durham Road, Bowburn, Co. Durham, DH6 5NG
Telephone: 0191 3770701
Fax: 0191 3771309

Hereby declares that the electromechanical automatic door operating system.

EVOLVE POCKET DOOR PRO

Are intended to be incorporated into machinery or to be assembled with other machinery to constitute machinery covered by directive 2006/42/EC.

It is in conformity with the provisions of the following directives.

- Electromagnetic directive 2004/108/EC
- Low voltage directive 2006/95/EC

The partly completed machinery must not be put into service until the final machinery into which it is to be incorporated has been declared in conformity with the provisions of this Directive, where appropriate.

The technical file is maintained at:
PC Henderson Ltd, Durham Road, Bowburn, Co. Durham, DH6 5NG

Please Note

The original language of these instructions is English.

The airborne noise of the system under normal operating conditions does not exceed 70dB (A).

Release Operation

In the event of malfunction or there is no mains power, move the door manually

General Safety Precautions

The following precautions are an integral and essential part of the product and must be supplied to the end user. Read them carefully as they contain important indications for safe installation, use and maintenance. These instructions must be kept and forwarded to all possible future users of the system. This product must be used only for that which it has been expressly designed; any other use is to be considered improper and therefore dangerous.

The manufacturer cannot be held responsible for possible damage caused by improper erroneous or unreasonable use.

- Avoid operating in the proximity of moving mechanical parts
- Do not enter the field of danger of motorised door while in motion.
- Do not obstruct the motion of the motorised door as this may cause a situation of danger.
- Do not lean against or hang on the barrier when it is moving.
- Do not allow children to play or stay within the field of action of motorised door.
- In the case of breakdown or malfunction of the product, disconnect from the mains, do not attempt to repair or intervene directly & contact only qualified personnel.
- In order to guarantee that the system works efficiently and correctly it is indispensable to comply with the manufacturers indications thus having a periodic maintenance of motorised door carrier out by qualified personnel. In particular regular checks are recommended in order to verify that the safety devices are operating correctly.
- All installation, maintained and repair work must be documented and made available to the end user.

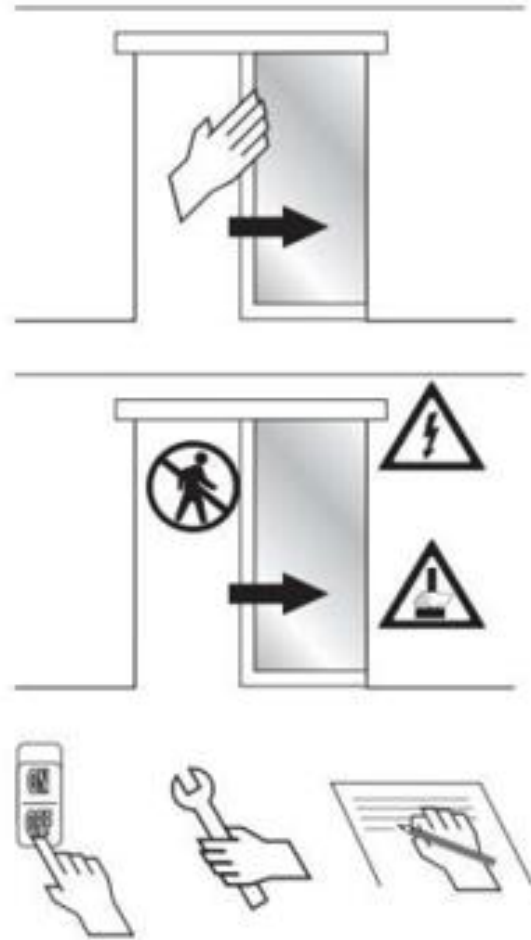

NOTE: Installer training available upon request, please note this attracts a fee.

EC Declaration of conformity – Machinery directive 200642/CE schedule II Part 2

Manufacturer:

PC Henderson Ltd

Address:

Durham Road, Bowburn, DH6 5NG

Name and address of authorized Installer:

Hereby Declare:

Evolve Pocket Door Pro

Installation at: (Installation address)

Conforms to Directive:

2006/42/CE – Machinery directive

States that it fulfils the application portion of the following standard

Date & Location of signature:

Signature of the person legally responsibility:

This completed document forms part of the European conformity (CE marking) - to be completed by installer and forwarded to end user.

Must be kept for ten years from installation date.

Markings

Each installation must clearly show the identification details of the motorized door or gate. The installer should apply hazard area notices required by applicable regulations, such as that shown below.

The installer must affix and complete the data tag supplied to the final installation in a suitable prominent position

 www.pchenderson.com	P C Henderson Limited Durham Road, Bowburn, County Durham, DH6 5NG, UK Tel:+44(0)191 377 7345 e-mail: sales@pchenderson.com	INSTALLER 	 DATE 
---	---	---	--

The installer must affix warning signs to the installation on both sides of the door, similar to those shown.



Installer to complete with contact details; Address & telephone number; to be completed with legible and permanent black ink.

Maintenance Schedule

Turn Off Power

- Clean the moving parts
- Check the belt tension
- Clean the sensors/remote fob (where applicable)
- Check the stability of the automatic system and make sure that all screws/connections are correctly tightened
- Check the alignment of doors and stop positions

Turn on the Power

- Check the stability of the door and that the movement is regular without friction
- Check that all command functions are operating correctly
- Check that the doors developed powers are in accordance with the present standards

Part Description	Part Number	Description of Function	Degradation of Component Factors	Maintenance Interval	Planned Replacement Schedule
Tension Wheel Assembly	668640	Supports belt movement within machine	Cracking – excessive wear – slipping	From new – six months – once a year thereafter	Every 10 years of service*
Wheel Cover	668323	Moving part protective cover	Cracking – excessive wear – slipping	From new – six months – once a year thereafter	#
Toothed Belt	668610	Provides movement to doors within system	Fraying/shearing – elongation – discolouration	From new – six months – once a year thereafter	Every 2 years
Motor Unit	668600	Provides movement to doors within system	Repeated error messages – failure of machine	From new – six months – once a year thereafter	#
Hanger	220503	Door is suspended from hanger	Black deposit within track / on top of door	From new – six months – once a year thereafter	#

*or sooner dependent upon operating conditions

replacement only recommended when apparent excessive wear affects the performance of the installation

Proof book

This proof book contains technical references and records of installation, maintenance, repair and alterations carried out must be made available for any inspection by authorized bodies. This book should be completed by the installer and forwarded to the end user.

Specification of the Motorized door and installation

Customer:

Order Number:

Model & Description:

Dimension and Weight:

Location:

List of components installed

Motor/ Drive Unit:

Switch:

Remote fob:

Motion detector:

Sign off check sheet:

- | | |
|--|--|
| <input type="checkbox"/> Declaration of conformity filled out | <input type="checkbox"/> Henderson & the motor unit manufacturer |
| <input type="checkbox"/> Proof book filled out | Fitting instructions |
| <input type="checkbox"/> CE Label completed & installed in suitable location | <input type="checkbox"/> All documents left with end user |
| <input type="checkbox"/> Warning signs installed in suitable locations | <input type="checkbox"/> Signature of receipt |

Warning of residual risks and of foreseeable improper use

Inform the end user of risk points regarding risk and foreseeable improper risks.

Proof book

Description of the work

Installation
Start Up
Adjustments
Maintenance
Repairs
Alterations

Details:

Installation
Start Up
Adjustments
Maintenance
Repairs
Alterations

Details:

Installation
Start Up
Adjustments
Maintenance
Repairs
Alterations

Details:

Installation
Start Up
Adjustments
Maintenance
Repairs
Alterations

Details:

Installation
Start Up
Adjustments
Maintenance
Repairs
Alterations

Details:
