

Fitting Instructions for top hung interior folding doors

Diagram 1

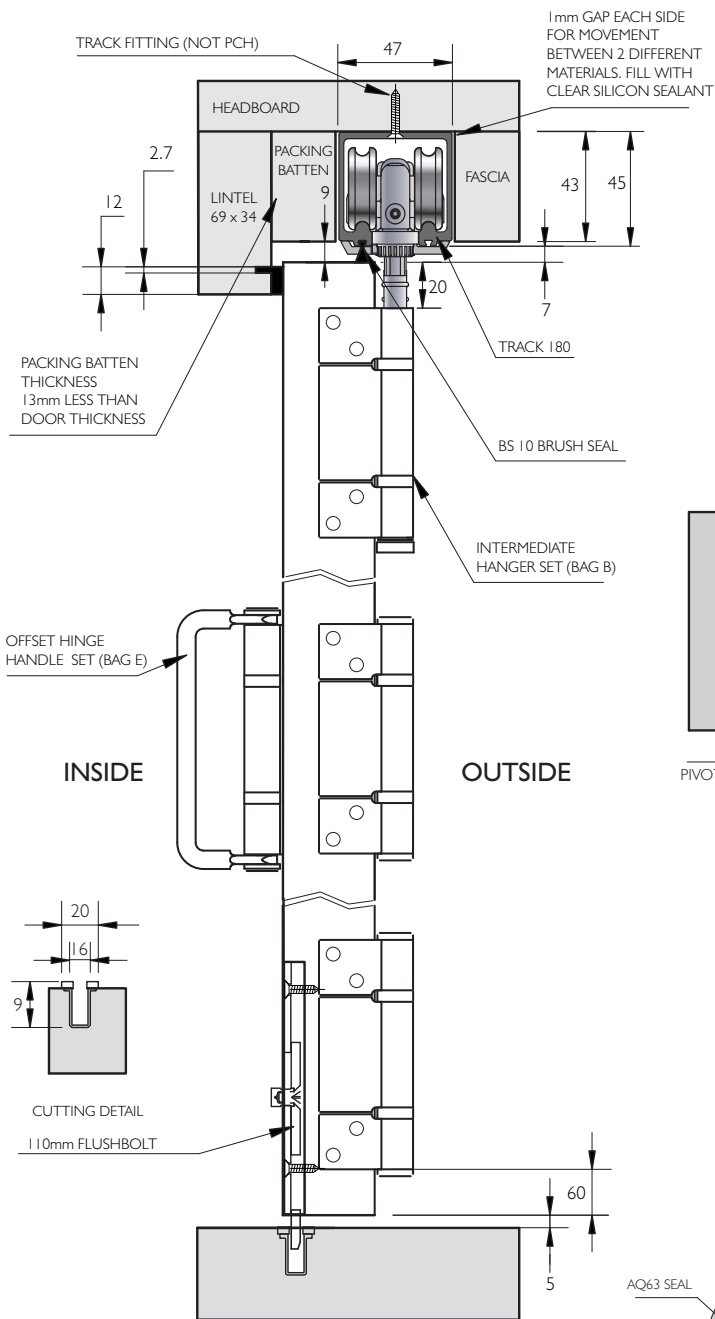

SYSTEM CAPACITY

Maximum leaf height- 3000mm Maximum leaf weight- 50kg
 Maximum leaf width- 926mm Maximum leaf thickness- 35-44mm

On systems using door leaves that are narrow and thick and the hypotenuse is more than the door width x 1.004 then a risk of camming exists (see diagram 11).

***For thicker or thinner doors please contact PC Henderson Technical Department technical@pchenderson.com*

Diagram 2

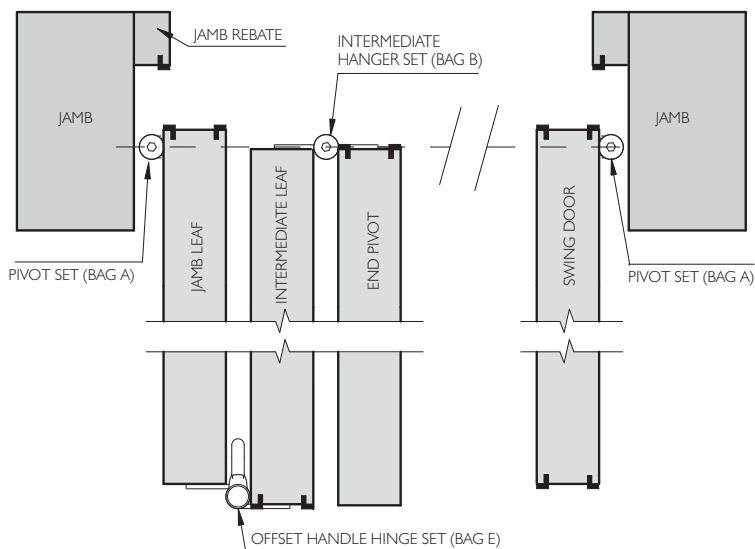
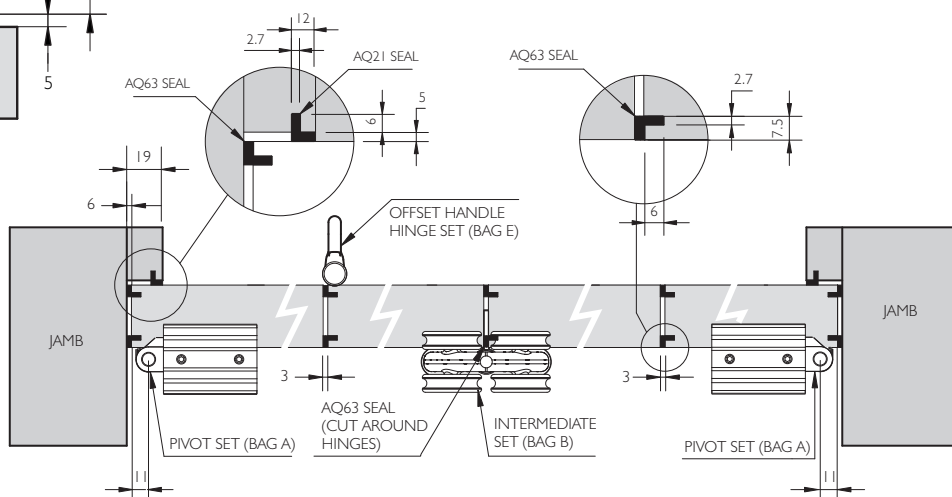

Diagram 3



PREPARATION

BAG A - Pivot Set
 BAG B - Intermediate Hanger Set

BAG C - Hinge Handle Set
 BAG D - End Hanger Set

BAG E - Offset Handle Hinge Set
 FB - 110mm Flush Bolt

Diagram 4

KIT 1 – Two door kit (RF50K1)

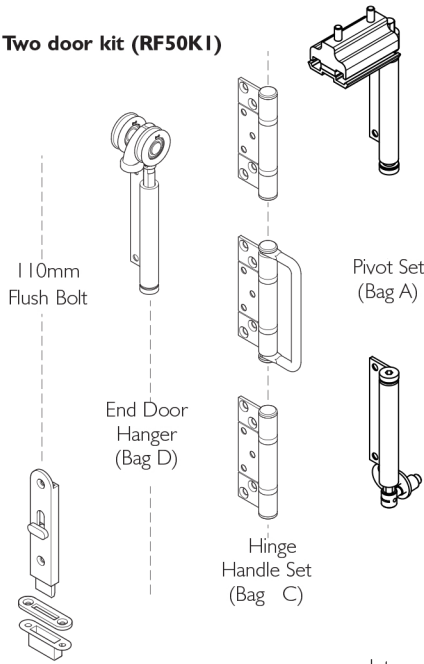

KIT 2 – Three door kit (RF50K2)

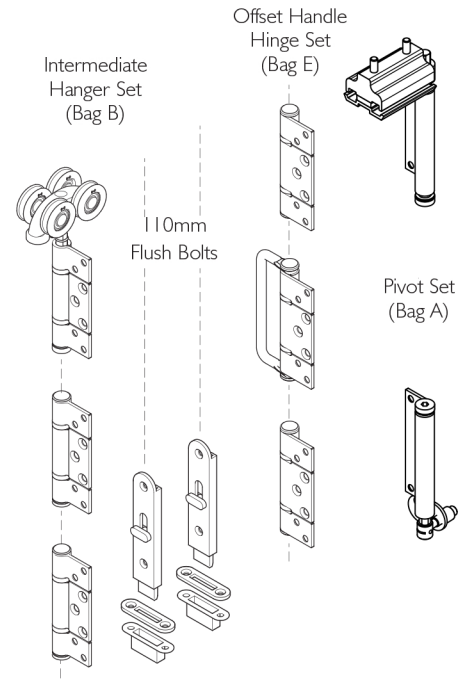

KIT 3 – Four door kit (RF50K3)

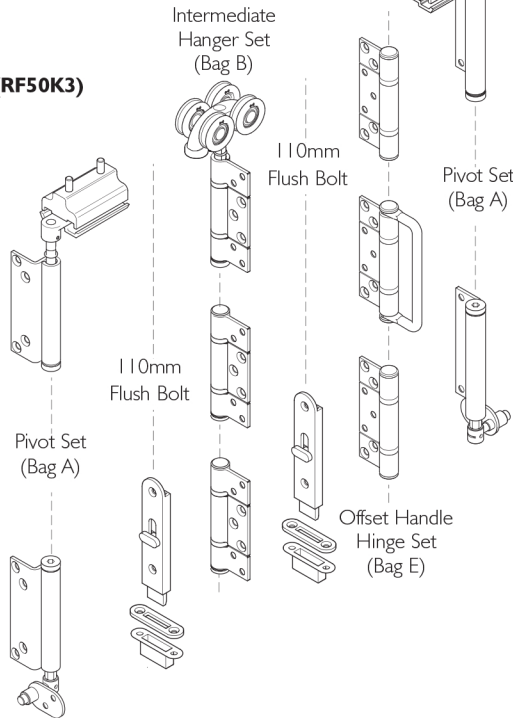

KIT 4 – Swing door kit (RFK4)

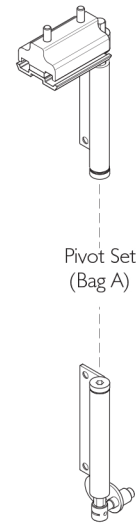
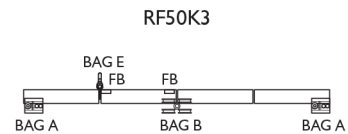
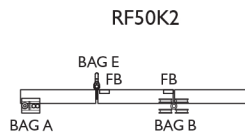
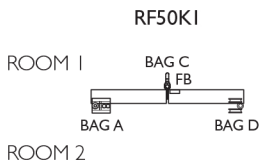
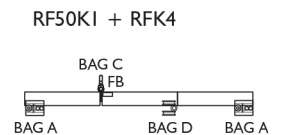
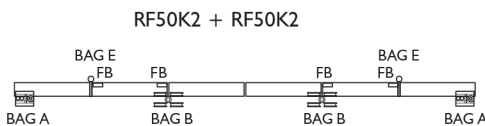
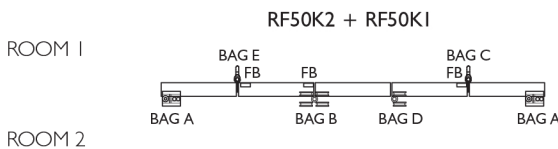

Diagram 5

Door Hardware - Configuration A, B and C



Door Hardware - Configuration D, E and F



Preparing the opening

Ensure the opening is square and all load bearing areas are suitable for the weight of the system. Take particular care to ensure there is sufficient strength in the structure above the opening to take the concentrated weight of the doors, when in the open stacked position. The Roomflex 50 system provides +/- 5mm of horizontal adjustment.

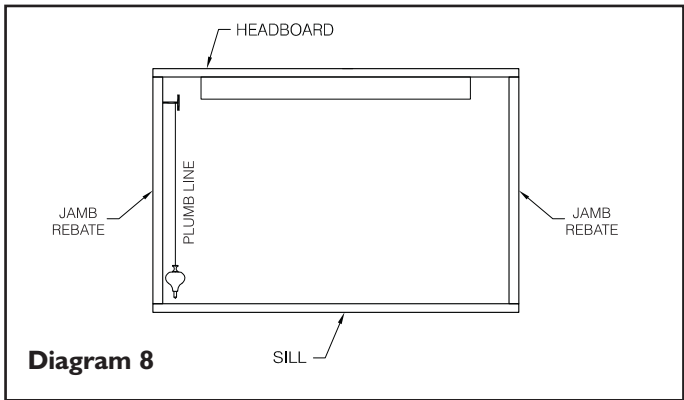
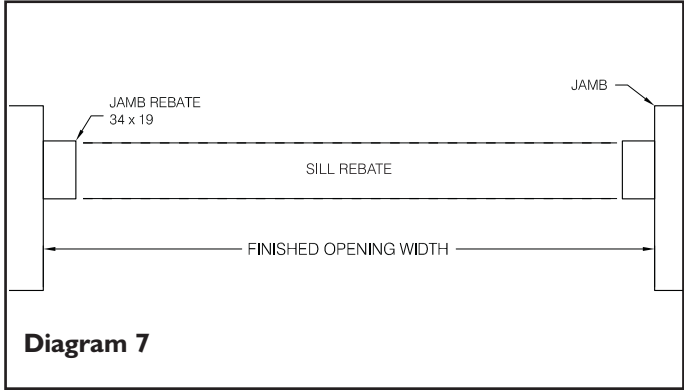
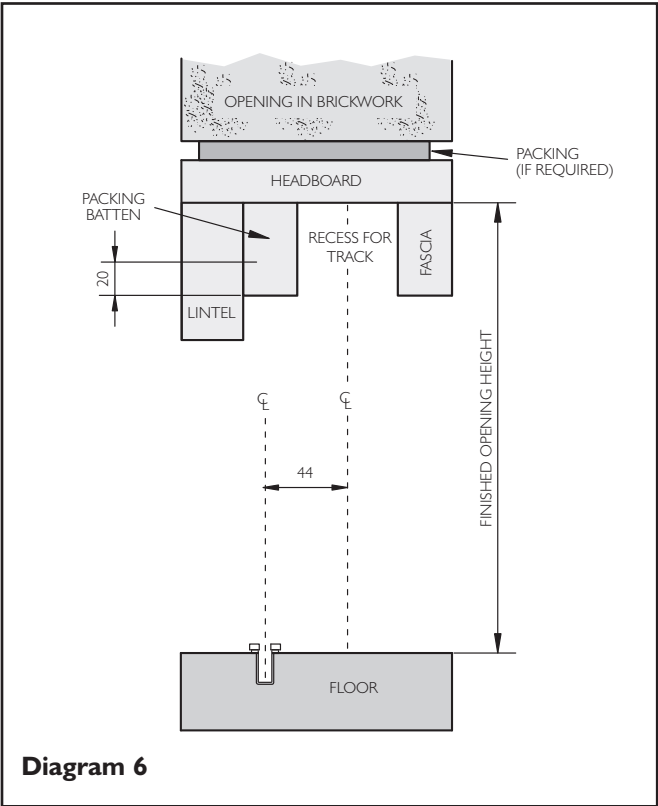

Preparing the door frame

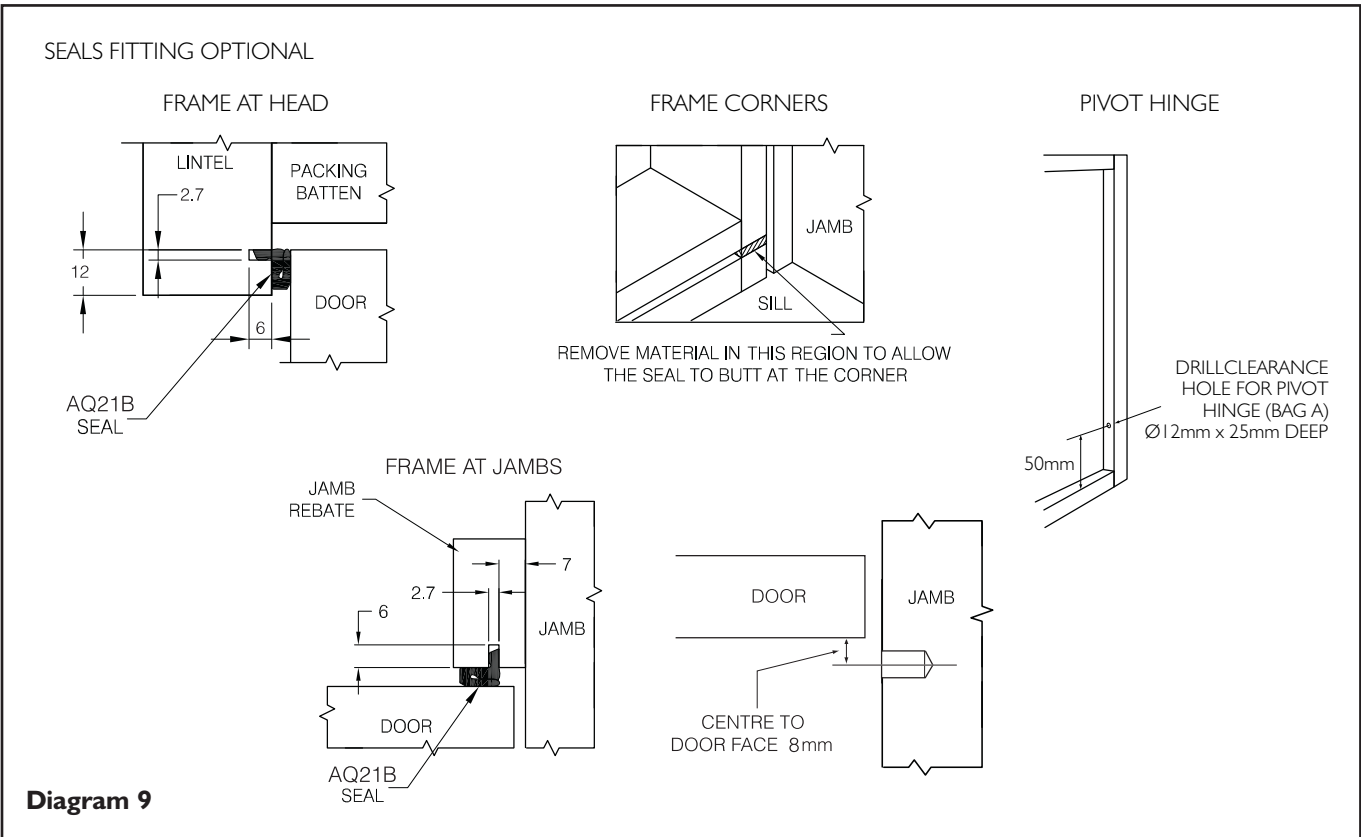

Preparing the door leaves

Door leaf width calculation

1. Decide how many door leaves you want in the opening.
2. Add together all of the clearances required between door leaves and the jambs (there will be one more than the number of door leaves). This is the total clearance figure.
3. Measure the finished opening width (W) and deduct from this the total clearance figure.
4. Divide this new figure (finished opening width minus total clearance) by the number of doors to produce the actual door width. (N.B. all doors with the Roomflex system are the same width). Ensure fits with Roomflex configurations.

Door leaf height calculation

Leaf height = finished opening height (see diagram 6) minus 57mm.

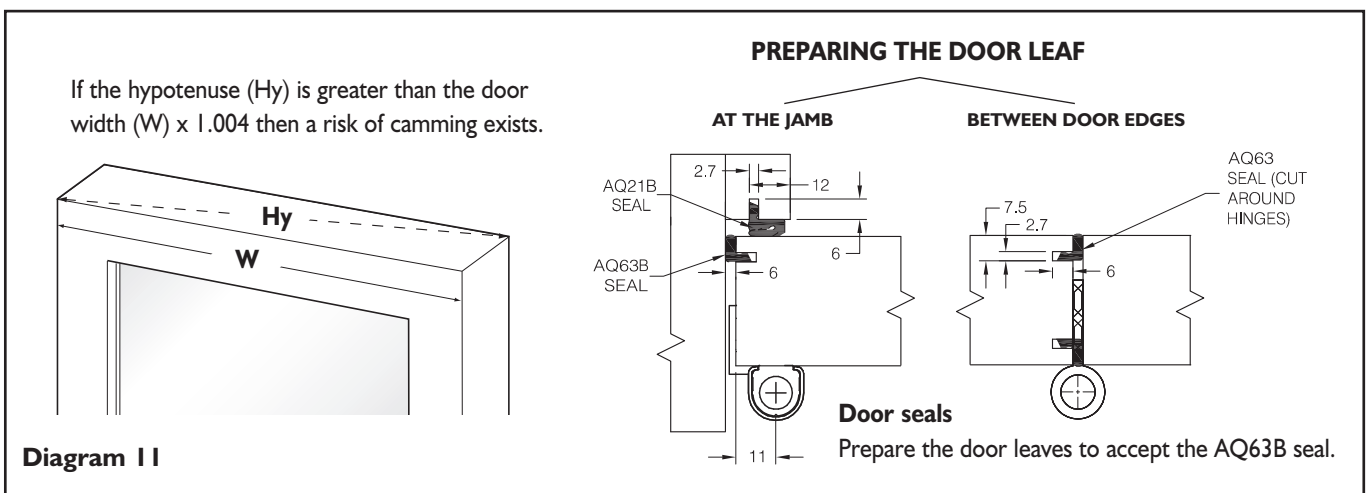
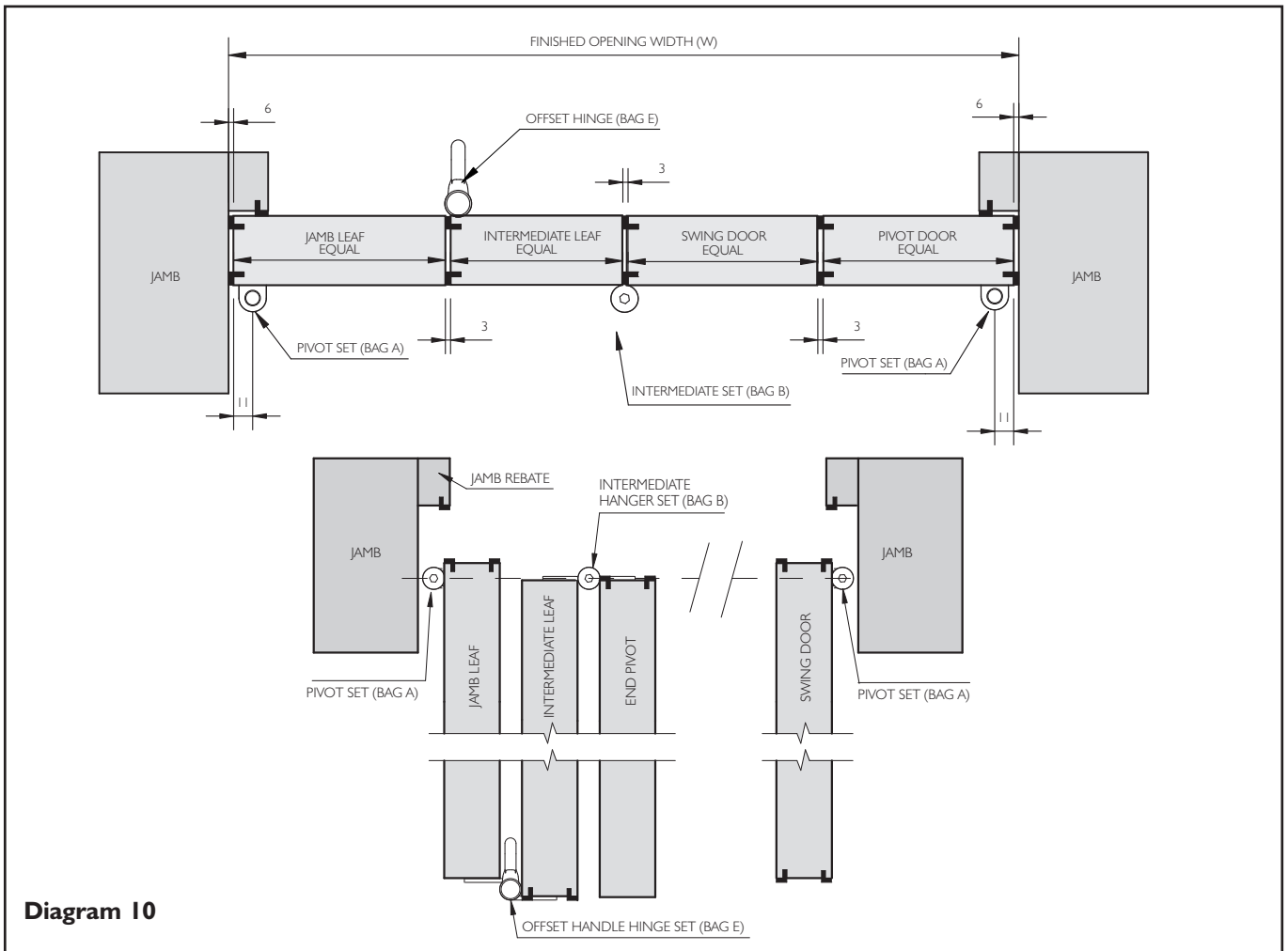

INSTALLATION

1. Ensure that you have all the required parts. Unpack the components and identify the parts. Lay the parts on the ground in the same configuration as they will be when installed. It is recommended that a light smear of general purpose grease is applied to all bolts prior to assembly.

2. Cut the track to the required length and pre-drill for fixings in accordance with diagram 12. Please note that the extra fixings are required where the doors stack together.

3. Remove all the wheel assemblies and pivot block from the hanger and pivot bolts, and disassemble top pivot block assembly.

4. Slide the wheel assemblies and track pivot block into the track in the correct order, orientation, and position and fix the track in position. Reassemble top pivot block assembly (see diagram 13).

5. For installation, assemble leaves in pairs via the hinges. To improve the ease of installation pre-drill pilot holes for all hinge parts. Fit bagged items A, B and C/E to first pair of leaves. **Please ensure all 5 screws are fixed per end hinge.**

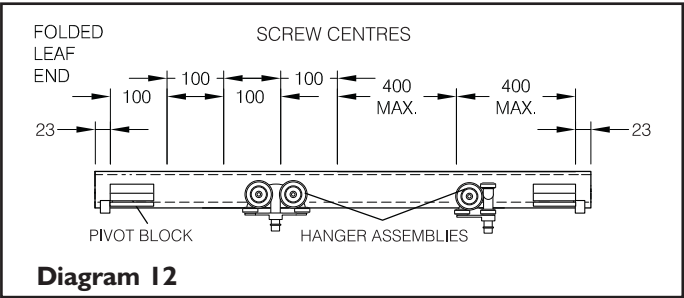

Diagram 12

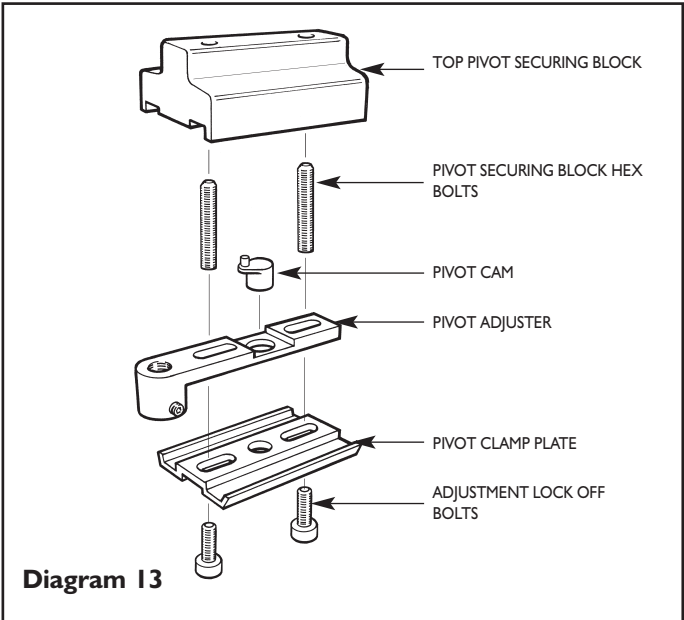

Diagram 13

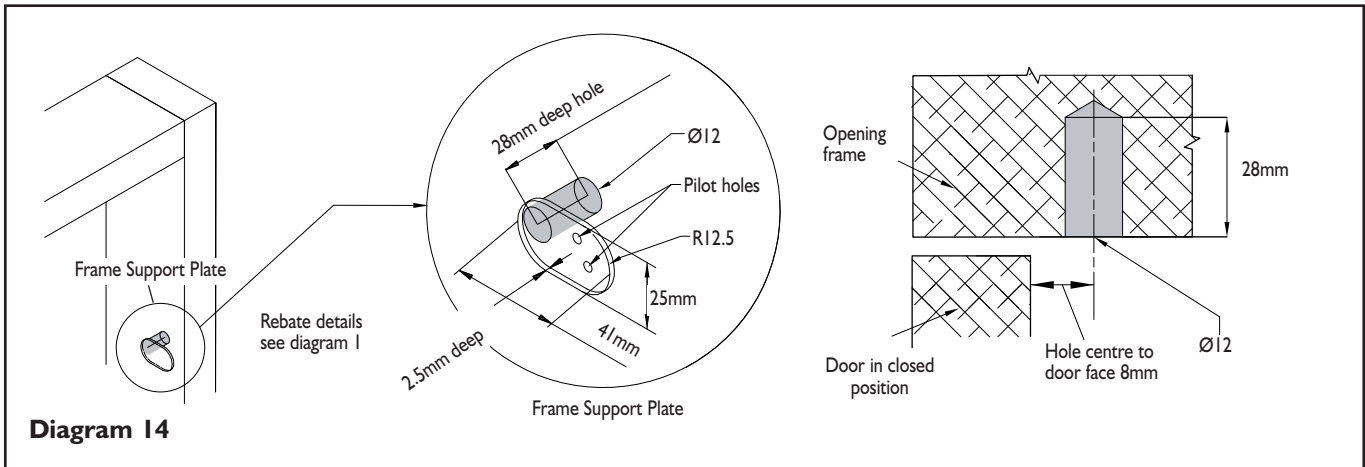

Diagram 14

6. Screw the frame support plate onto the opening frame preparation as shown in diagram 14.

7. Suspend pairs of leaves by engaging top pivot and hanger bolts using 5mm allen key supplied (see top of diagram 15).

8. Support leaves from underneath and align pivot leaf vertically to enable main strap bolt to align with the link arm, as shown in diagram 16.

9. Lift the next pair of leaves into position and support their weight by screwing the hanger strap bolt into the hanger wheel assembly and fixing the second and third leaves together.

10. Continue this procedure until all leaves are fitted.

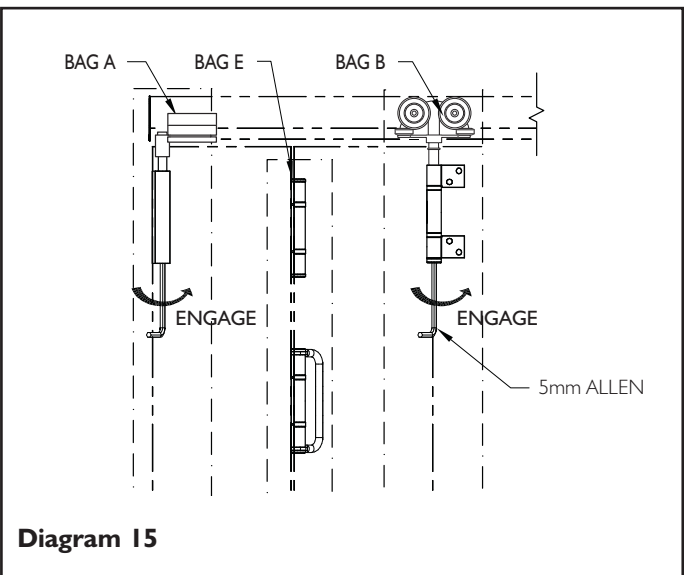

Diagram 15

6 ADJUSTMENT

Height Adjustment ($\pm 3\text{mm}$)

1. Close leaves and adjust the door height to achieve an equal gap between the top of the leaves and the track (a 9mm gap is recommended). (see diagram 17).
2. Once the adjustment is complete use the allen key to tighten the locking hanger grub screw until secure.

Lateral Adjustment

1. With the unit still in the closed position, slide the set of leaves towards the jamb to obtain the desired gap between the jamb and the pivot door. A gap of 6mm is recommended using the adjustment cam. Once in position tighten the clamp screws. (see diagram 18).
2. Adjust end pivot hinge to ensure the clearance between the pivot door and frame is uniform, as shown in diagram 19.
3. Once the pivot door is in the correct position insert and tighten the locking pivot grub screw from the inside position as shown in diagram 18.

CARE AND MAINTENANCE

To provide years of trouble free operation, it is recommended that the track is kept free from dirt and debris. Periodically replace the general purpose grease on all bolts. To prolong the appearance of the exposed hinge parts, it is recommended they are periodically washed with soap and water. Maintenance is required on all components including stainless steel to validate manufacturers warranty. For further maintenance details please refer to our website, www.pchenderson.com.

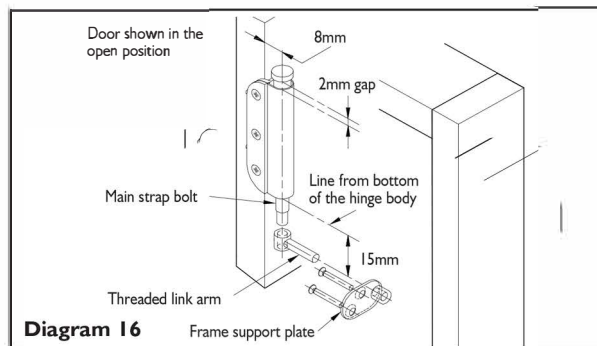

Diagram 16

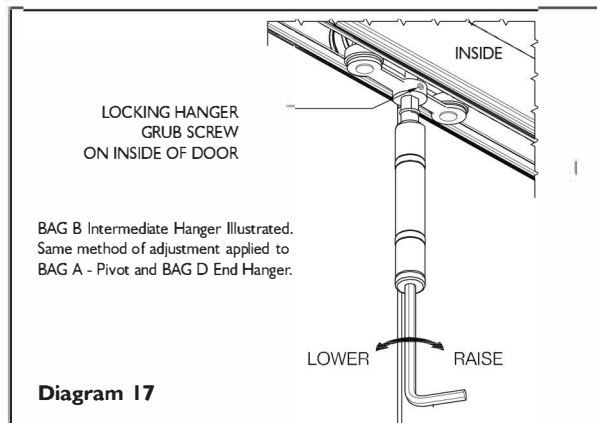

Diagram 17

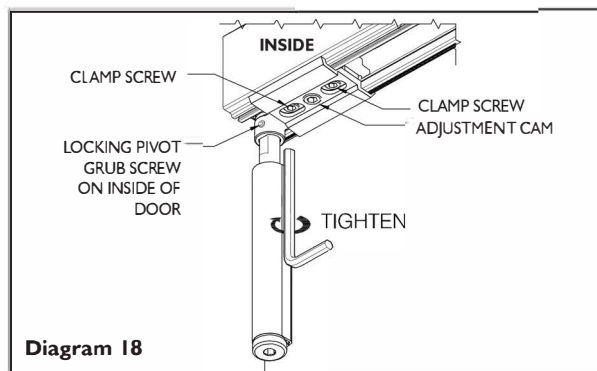

Diagram 18

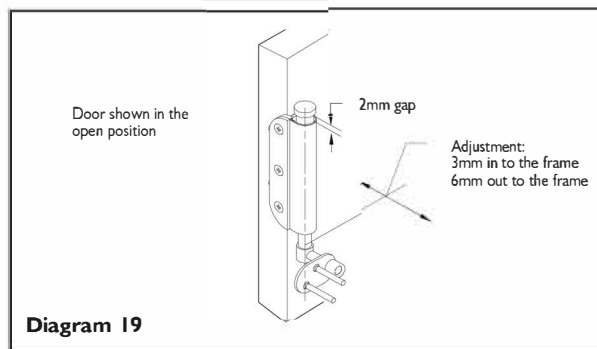
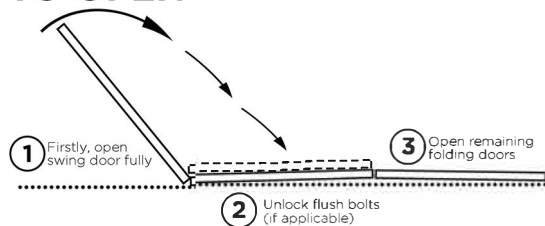

Diagram 19

(All dimensions in mm)

OPERATION INSTRUCTIONS

TO OPEN



TO CLOSE

