

# Model: RRT5212 operating instructions



**CAPACITY**

Rivnuts: M5 - M6 - M8 - M10 - M12 - Standard

Rivstuds: M5 - M6 - M8 - Optional

Rivnuts: UNC - 10.24, 1/4.20, 5/16.18, 3/8.16, 1/2.13 - Optional

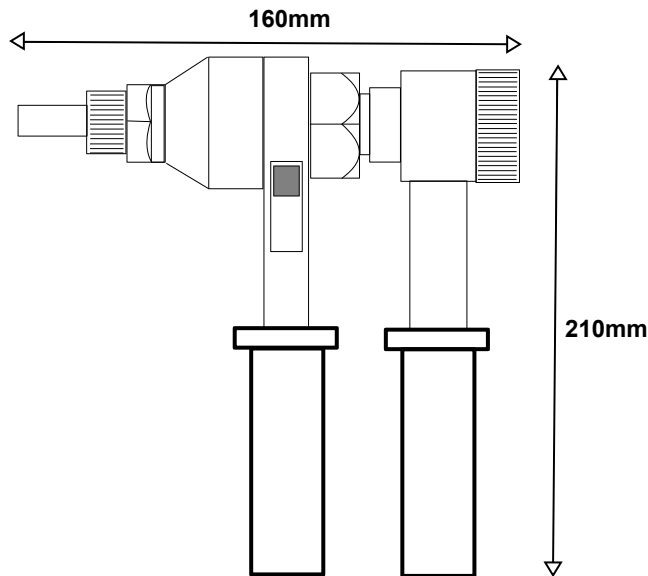

Unscrew anvil and locknut

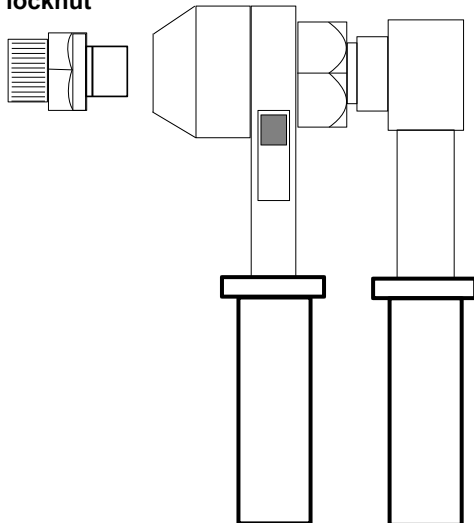

Pull mandrel to remove from tool body.

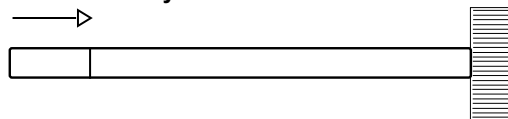

**IMPORTANT - WHEN USING M5 AND M6 RIVNUTS, ALWAYS TEST SET RIVNUTS INTO SCRAP MATERIAL. ONLY A SMALL AMOUNT OF FORCE IS REQUIRED TO SET THESE RIVNUTS.**



**UNNECESSARY OVER TIGHTENING MAY RESULT IN DAMAGE TO THE TOOL MANDREL OR RIVNUT THREADS.**

**IMPORTANT - MAINTENANCE TIP**  
 APPLY GREASE TO THE LOAD TRANSFER THREAD.  
 THIS IS DONE BY WINDING THE TOOL APART, CLEANING AND GREASING THE THREAD.  
 MAINTENANCE TIME APPROX 5 MINUTES.

# RRT5212 setting a rivnut

