

HAWK ENGINE PARTS CALALOGUE

一. 气缸头、气缸体 CYLINDER HEAD, CYLINDER BODY



序号 RefNo	编号 Part No	中文名称 Chinese Description	英文名称 English Description	数量 Qty	备注 Remark
1	FN200-015000-0000	气缸体	Cylinder body	1	
2	Q/HSQ 5789-2003	螺栓 M6×22	Bolt M6×22	2	
3	FJ100-000001-1014	定位销 φ10×14	Ring φ10×14	2	
4	FN200-010014-0000	缸体密封垫	Gasket, cylinder body	1	
5	FJ100-000001-1020	定位销 φ10×20	Pin φ10×20	3	
6	Q/HSQ 7757-2003	O 型圈 φ10×1.6	O-ring φ10×1.6	1	
7	FN200-010050-0000	缸头密封垫	Gasket, cylinder head	1	
8	FJ100-000002-0002	铜垫 φ8×17×2	Copper backing φ8×17×2	1	
9	Q/HSQ 5787-2003	螺栓 M8×83	Bolt M8×83	1	
10	FN200-011100-0000	气缸头组合	Cylinder head assy	1	
11	Q/HSQ 7757-2003	O 型圈 φ33.5×3	O-ring φ33.5×3	1	
12	FK100-010030-0000	进气管	Guide, in valve	1	
13	GB/T 5783-2000	螺栓 M6×20	Bolt M6×20	2	
14	FJ100-011012-0000	排气管双头螺栓	Stud	2	M8×45 或 M8×40
15	FJ100-010002-0000	缸头盖密封垫	Gasket, cylinder head cover	1	
16	FN200-010101-0000	缸头盖	Cylinder head cover	1	
17	Q/HSQ 5789-2003	螺栓 M6×28	Bolt M6×28	3	
18	FJ100-000002-0002	铜垫 φ6×13×1.5	Copper backing φ6×13×1.5	1	
19	Q/HSQ 5787-2003	螺栓 M6×12	Bolt M6×12	1	
20	FJ100-010001-0000	火花塞	Spark plug	1	

二. 配气机构 VALVE SYSTEM

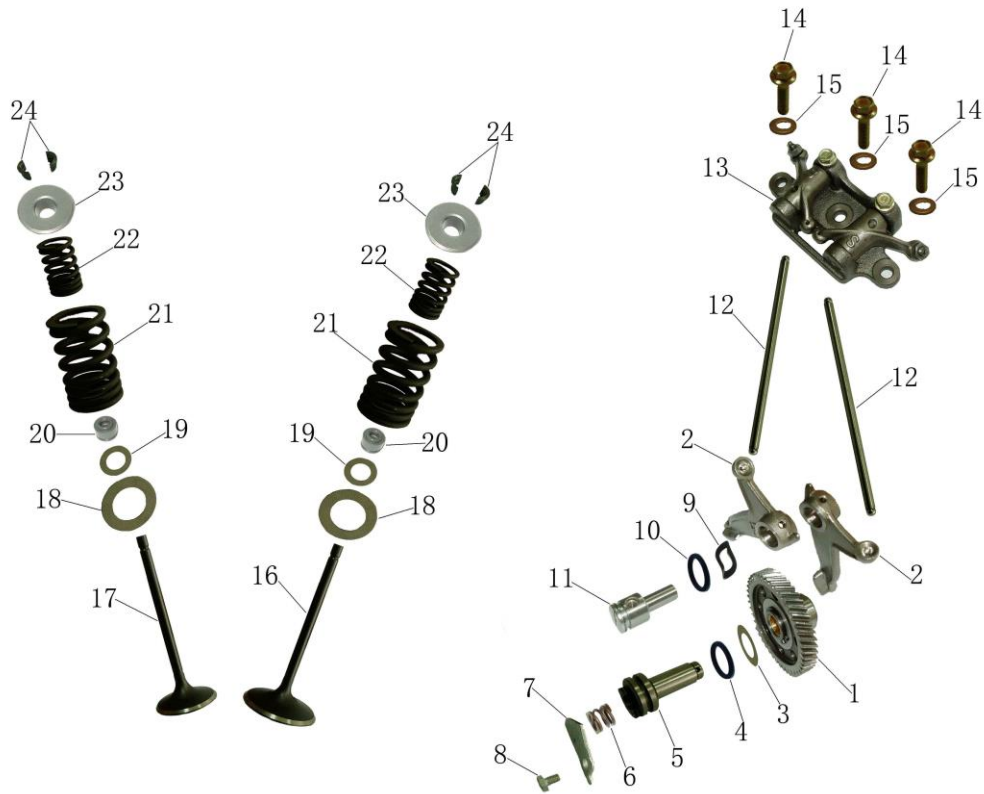

序号 RefNo	编号 Part No	中文名称 Chinese Description	英文名称 English Description	数量 Qty	备注 Remark
1	FJ100-012000-0000	配气凸轮部件	Camshaft comp	1	
2	FJ100-010021-0000	下摇臂	Lower rocker	2	
3	FJ100-010025-0000	凸轮芯轴垫圈	Washer	1	
4	Q/HSQ 7757-2003	O 型圈 $\phi 20 \times 2.5$	O-ring $\phi 20 \times 2.5$	1	
5	FN200-010024-0000	凸轮芯轴	Camshaft spindle	1	
6	FJ100-030036-0000	压簧	Pressing spring	1	
7	FJ100-030035-0000	凸轮芯轴压板	Pressing plate, camshaft	1	
8	GB/T 5783-2000	螺栓 M6 \times 12	Bolt M6 \times 12	1	
9	FJ100-010023-0000	波形垫圈	Washer	1	
10	Q/HSQ 7757-2003	O 型圈 $\phi 17 \times 2.5$	O-ring $\phi 17 \times 2.5$	1	
11	FN200-010022-0000	下摇臂轴	Shaft, lower rocker	1	
12	FN200-010010-0000	推杆	Push lever	2	
13	FJ1F0-013000-0000	上摇臂	Valve rocker	1	
14	Q/HSQ 5789-2003	螺栓 M8 \times 32	Bolt M8 \times 32	3	
15	FJ100-000002-0002	铜垫 $\phi 8 \times 17 \times 2$	Copper backing $\phi 8 \times 17 \times 2$	3	
16	FN200-011001-0000	进气门	Inlet valve	1	
17	FN200-011002-0000	排气门	Outlet valve	1	
18	FJ100-011009-0000	气门外弹簧座圈	Spring seat valve, inner	2	
19	FJ100-011008-0000	气门内弹簧座圈	Spring seat valve, outer	2	
20	FJ100-011106-0000	档油罩	Seal valve	2	
21	FJ100-011007-0000	气门外弹簧	Outer spring	2	

二. 配气机构 VALVE SYSTEM

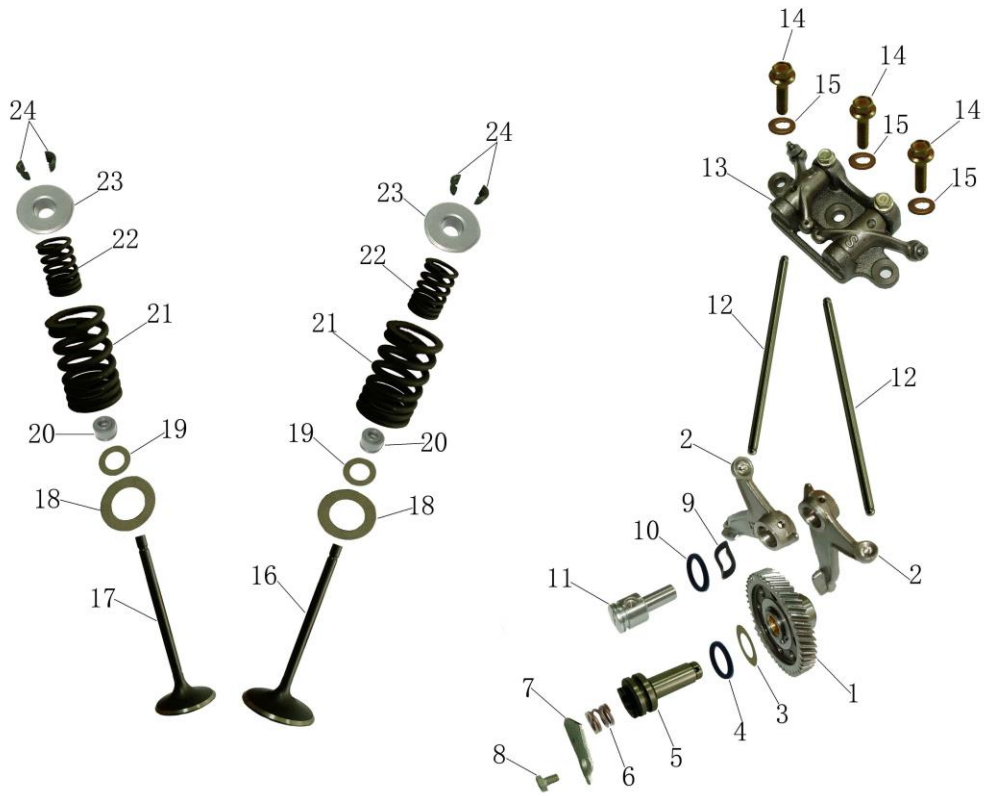

序号 RefNo	编号 Part No	中文名称 Chinese Description	英文名称 English Description	数量 Qty	备注 Remark
22	FJ100-011006-0000	气门内弹簧	Inner spring	2	
23	FJ100-011004-0000	气门弹簧座	Spring seat, valve	2	
24	FJ100-011003-0000	气门锁夹	Lock plate	4	

三. 磁电机、起动电机、左曲轴箱盖

MAGNETO、START MOTOR、LEFT CRANKCASE COVER

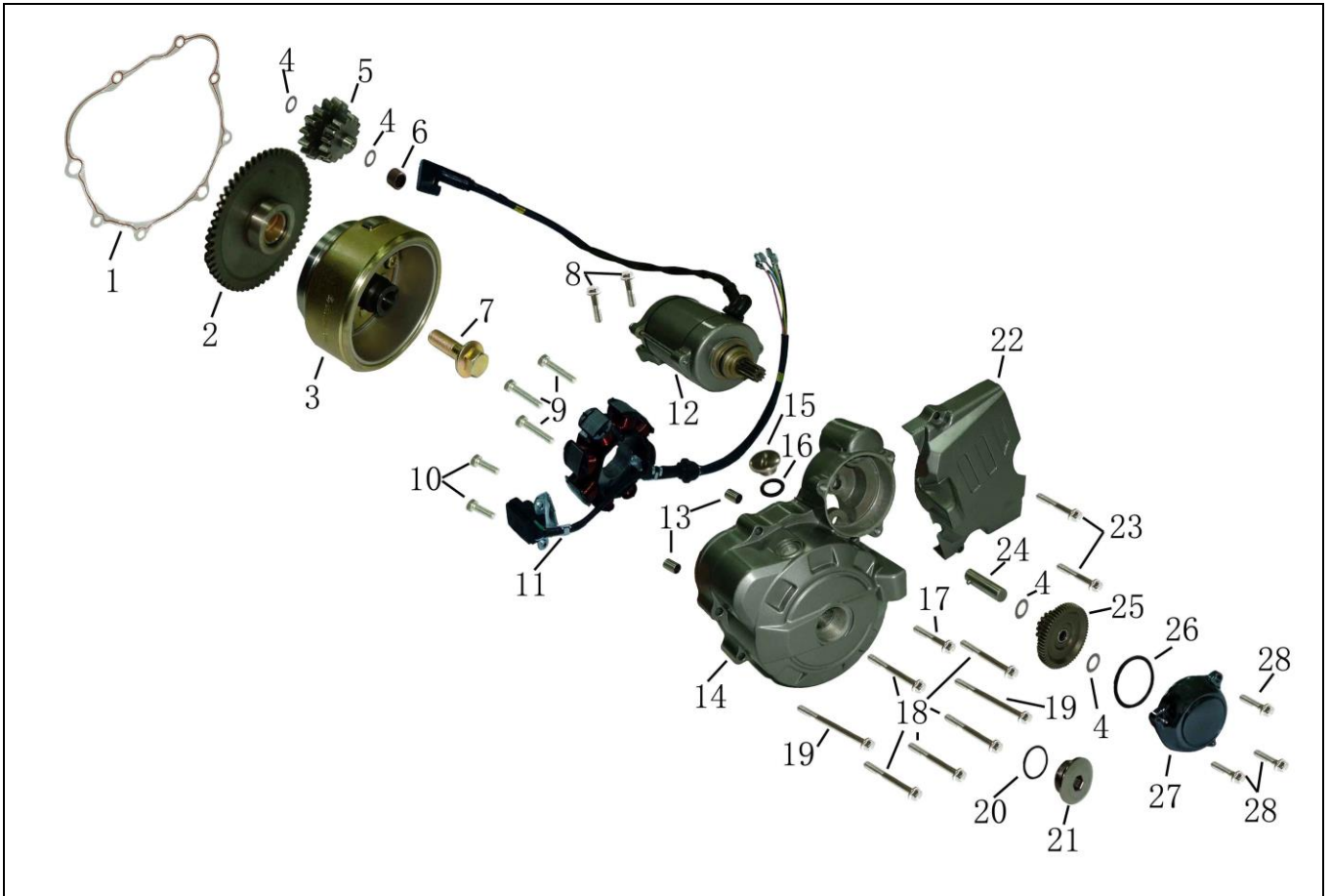

序号 RefNO	编号 Part No	零部件名称 Chinese Description	英文名称 English Description	数量 Qty	备注 Remark
1	FJ100-030048-0000	左曲轴箱盖垫	Washer, left crankcase cover	1	
2	FN200-062017-0000	大齿(链)盘组合	Sprocket assy	1	
3	FN200-071001-0000	飞轮	Flywheel	1	
4	FJ100-062023-0000	垫片	Washer	4	
5	FJ100-062020-0000	双联齿轮(一)	Gear	1	
6	GB/T 290	滚针 HK10/14/10	Roller needleHK10/14/10	1	
7	Q/HSQ 5789-2003	螺栓 M10×35	Bolt M10×35	1	
8	Q/HSQ 5787-2003	螺栓 M6×28	Bolt M6×28	2	
9	GB/T 5783-2000	螺栓 M5×25	Bolt M5×25	3	
10	GB/T 5783-2000	螺栓 M5×16	Bolt M5×16	2	
11	FN200-071100-0000	定子组合	Base assy	1	
12	FN200-062100-0000	起动电机组合	Start motor assy	1	
13	FJ100-000001-1014	定位销 φ10×14	Pin φ10×14	2	
14	FJ100-035001-0000	左前盖	Engine left cover, front	1	
15	FF100-035006-0000	视孔盖 B	Oylet cover B	1	
16	Q/HSQ 7757-2003	O 型圈 φ13×2.65	O-ringφ13×2.65	1	
17	Q/HSQ 5787-2003	螺栓 M6×25	Bolt M6×25	1	
18	Q/HSQ 5787-2003	螺栓 M6×40	Bolt M6×40	5	
19	Q/HSQ 5787-2003	螺栓 M6×50	Bolt M6×50	2	
20	Q/HSQ 7757-2003	O 型圈 φ27.4×2.4	O-ring φ27.4×2.4	1	

21	FF100-035005-0000	视孔盖 A	Engine oil sight cover A	1	
----	-------------------	-------	--------------------------	---	--

三. 磁电机、起动电机、左曲轴箱盖

MAGNETO、START MOTOR、LEFT CRANKCASE COVER

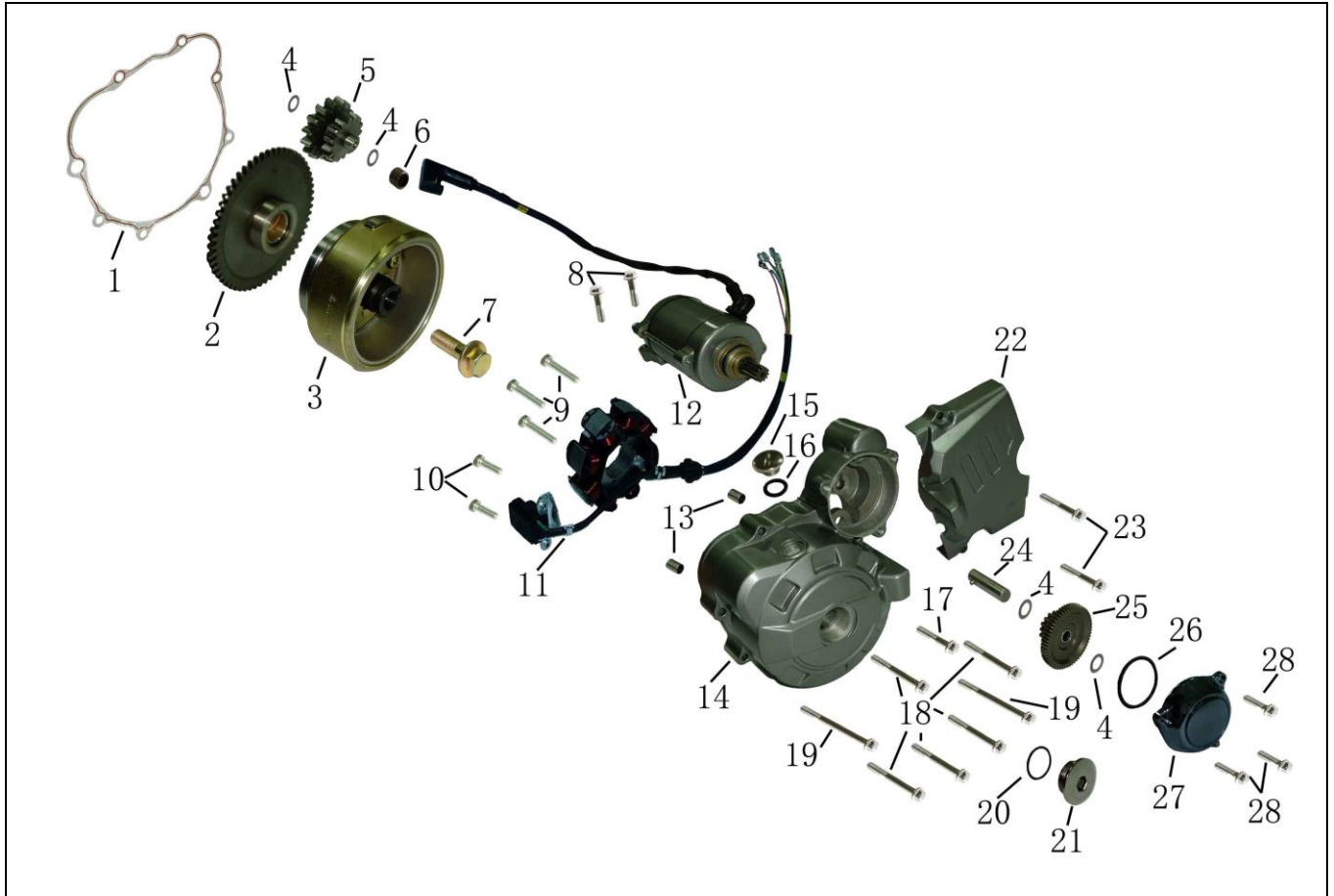

序号 RefNO	编号 Part No	零部件名称 Chinese Description	英文名称 English Description	数量 Qty	备注 Remark
22	FJ100-035002-0000	左后盖	Engine left cover, rear	1	
23	Q/HSQ 5787-2003	螺栓 M6×32	Bolt M6×32	2	
24	FJ100-062029-0000	双联齿轮（二）轴组合	Gear(2) shaft assy	1	
25	FJ100-062027-0000	双联齿轮（二）组合	Gear(2) assy	1	
26	Q/HSQ 7757-2003	O 型圈 φ63×3	O-ring φ63×3	1	
27	FJ100-035003-0000	齿轮室盖	Gear cover	1	
28	Q/HSQ 5787-2003	螺栓 M6×20	Bolt M6×20	3	

四. 离合器、右曲轴箱盖 CLUTCH、RIGHT CRANKCASE COVER

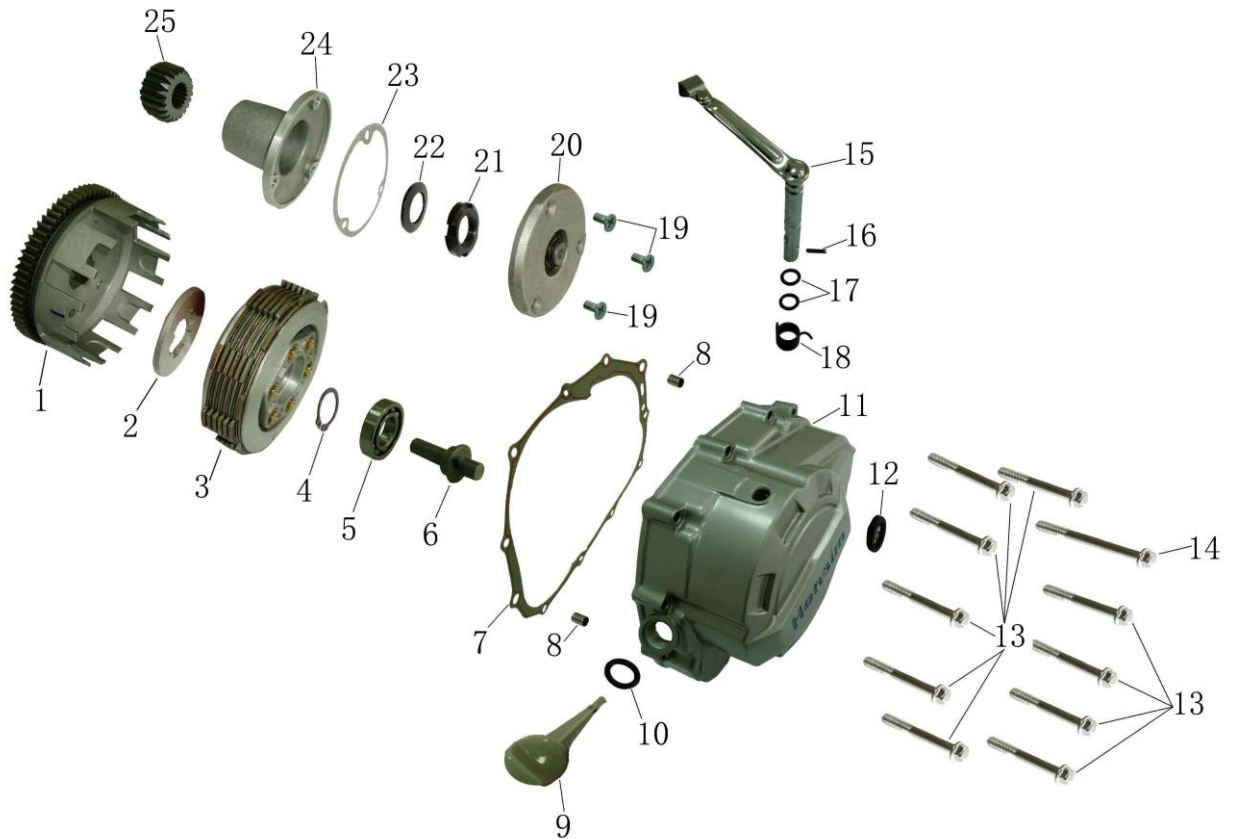

序号 RefNO	编号 Part No	零部件名称 Chinese Description	英文名称 English Description	数量 Qty	备注 Remark
1	FN200-052000-0000	主离合器部件	Main clutch comp	1	
2	FJ100-052007-0000	花键垫圈	Gasket	1	
3	FN200-052200-0000	从动盘组合	Driven plate	1	
4	FJ100-041012-0000	主轴挡圈	Retainer ring	1	
5	GB 276	轴承 16003	Bearing16003	1	
6	FN200-052013-0000	分离杆	Lever	1	
7	FJ100-030047-0000	右曲轴箱盖垫	Washer	1	
8	FF100-000001-0812	定位销 $\phi 8 \times 12$	Pin $\phi 8 \times 12$	2	
9	FJ100-034005-0000	机油尺	oil level gauge	1	
10	Q/HSQ 7757-2003	O型圈 $\phi 18 \times 3$	O-ring $\phi 18 \times 3$	1	
11	FJ100-034100-0000	右曲轴箱盖组合	Crankcase	1	
12	FF100-034109-0000	机油视孔窗	Oylet window	1	
13	Q/HSQ 5787-2003	螺栓 M6 \times 40	Bolt M6 \times 40	10	
14	Q/HSQ 5787-2003	螺栓 M6 \times 50	Bolt M6 \times 50	1	
15	FJ100-034104-0000	离合器分离杆组合	Clutch lever assy	1	
16	GB/T 879	销 3 \times 16	Pin $\phi 3 \times 16$	1	
17	Q/HSQ 7757-2003	O型圈 $\phi 8 \times 2$	O-ring $\phi 8 \times 2$	2	
18	FJ100-034010-0000	回位弹簧	Spring	1	
19	GB/T 819-2000	螺栓 M5 \times 10	Bolt M5 \times 10	3	
20	FN200-020103-0000	滤清器盖	Filter cover	1	
21	FJ100-020107-0000	圆螺母	Nut	1	

四. 离合器、右曲轴箱盖 CLUTCH、RIGHT CRANKCASE COVER

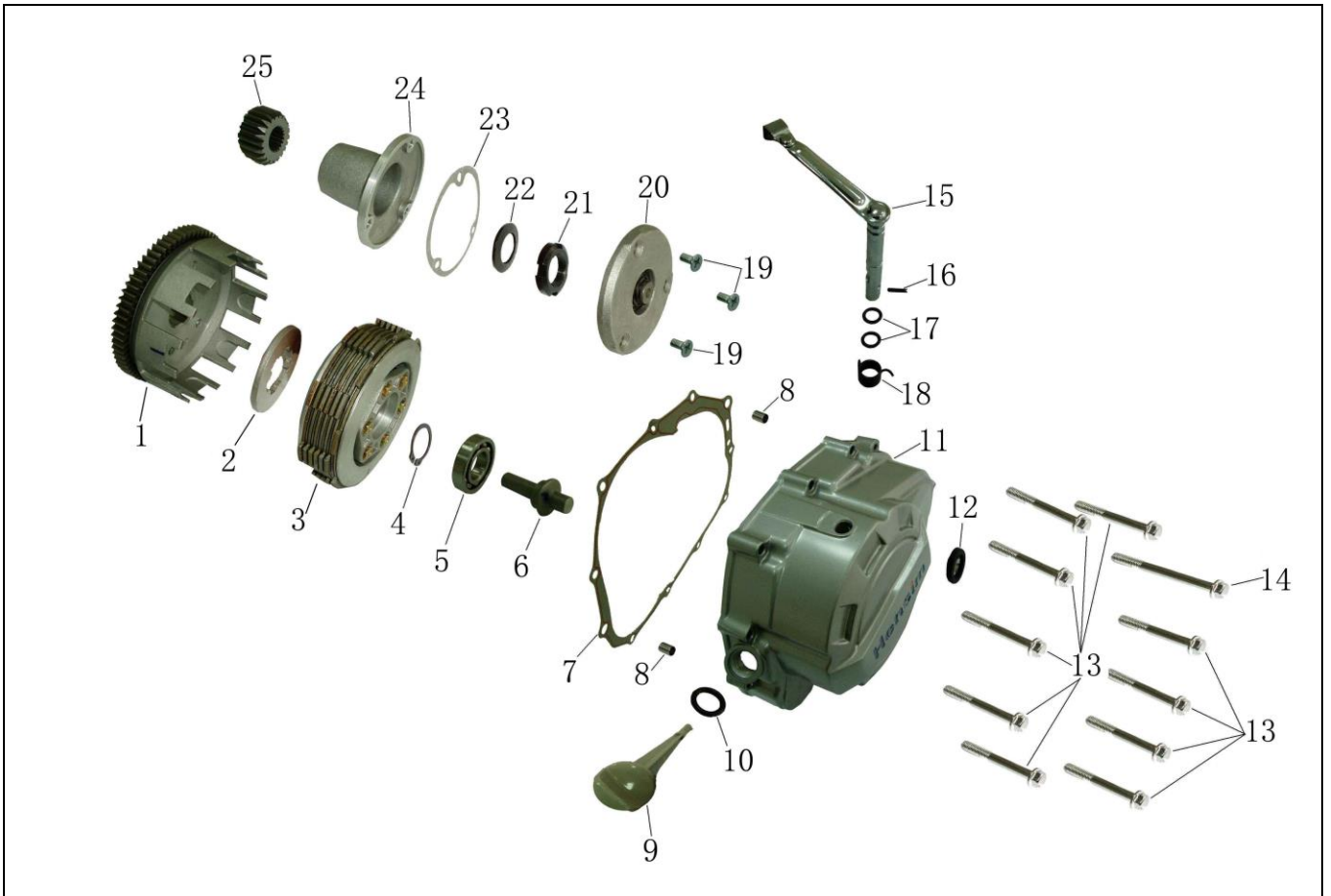

序号 RefNO	编号 Part No	零部件名称 Chinese Description	英文名称 English Description	数量 Qty	备注 Remark
22	FJ100-020108-0000	碟形垫圈	Washer	1	
23	FJ100-020102-0000	密封垫	Washer	1	
24	FN200-020101-0000	滤清器体	Filter	1	
25	FN200-022201-0000	主动齿	Driving gear tooth	1	

五. 左右曲轴箱、变速机构、曲轴、活塞

CRANKCASE, GEARSHIFT, CRANKSHAFT, PISTON

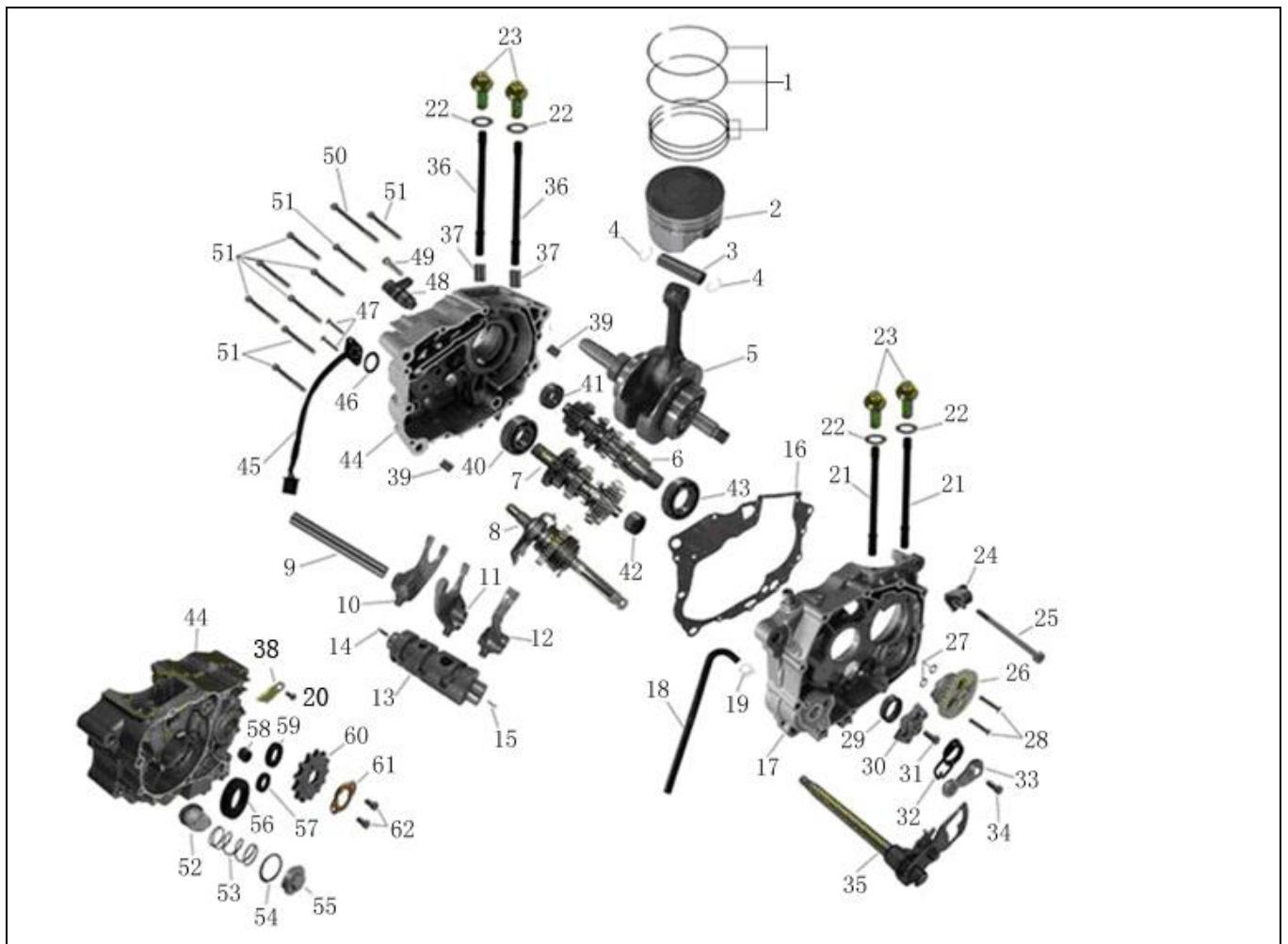

序号 RefNO	编号 Part No	零部件名称 Chinese Description	英文名称 English Description	数量 Qty	备注 Remark
1	FN200-021002-0000	活塞环 (1)	Piston ring 1	1	
	FN200-021003-0000	活塞环 (2)	Piston ring 2	1	
	FN200-021010-0000	油环组合	Oil ring comp	1	
2	FN200-021001-0000	活塞	Piston	1	
3	FN200-020003-0000	活塞销	Piston pin	1	
4	FN200-020001-0000	活塞销挡圈	Ring, piston pin	2	
5	FN200-022000-0000	曲轴连杆部件	Crankshaft connecting rod comp	1	
6	FN2E0-041000-0000	主轴组合	Main shaft comp	1	
7	FN2E0-042000-0000	副轴组合	Counter shaft comp	1	
8	FJ200-061000-0000	起动轴部件	Start shaft comp	1	
9	FJ100-043005-0000	拨叉轴 A	Shaft A	1	
10	FN2E0-043002-0000	拨叉 I	Shift fork I	1	
11	FJ100-043003-0000	拨叉 II	Shift fork II	1	
12	FJ100-043004-0000	拨叉 III	Shift fork III	1	
13	FN2E0-043001-0000	变速鼓	Gearshift drum	1	
14	FJ100-043012-0000	铜触点组合	Copper connect assy	1	
15	FJ100-043008-0000	销轴 A	Shaft A	1	

16	FN200-030001-0000	曲轴箱密封垫	Gasket	1	
17	FN200-031100-0000	右曲轴箱组合	Right crankcase assy	1	

五. 左右曲轴箱、变速机构、曲轴、活塞

CRANKCASE、GEARSHIFT、CRANKSHAFT、PISTON

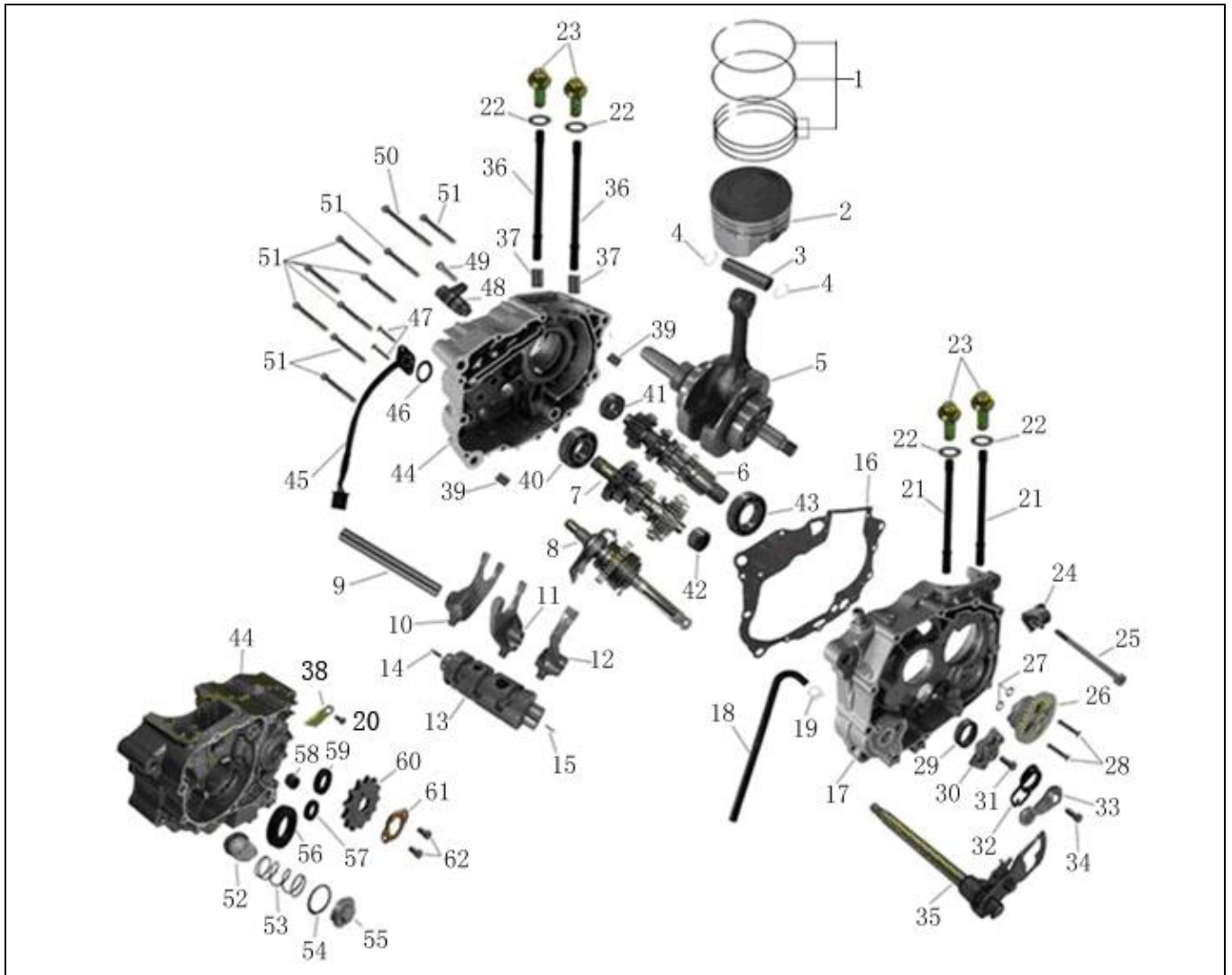

序号 RefNO	编号 Part No	零部件名称 Chinese Description	英文名称 English Description	数量 Qty	备注 Remark
18	FJ100-030015-0000	通气管	Tube	1	
19	FJ100-030016-0000	通气管卡箍	Clamp	1	
20	GB/T 5783-2000	六角螺栓 M6×12	Bolt M6×12	1	
21	FM200-030003-0000	气缸螺栓 A M8×138	Bolt A M8×138	2	
22	FJ100-010029-0000	缸头螺母垫圈	Washer	4	
23	FJ100-010028-0000	缸头螺母	Nut	4	
24	FJ100-030044-0000	离合器拉索支架	Stand, clutch rod	1	
25	GB/T 29.2-2000	螺栓 M6×55	Bolt M6×55	1	
26	FN200-033000-0000	机油泵部件	Oil pump assembly	1	
27	Q/HSQ 7757-2003	O 型圈 φ9×2.4	O-ring φ9×2.4	2	

28	GB/T 819-2000	螺栓 M6×30	Bolt M6×30	2	
29	GB/T 290	滚针 HK21/28/10	Needle rollerHK21/28/10	1	
30	FJ100-043007-0000	五星轮	Pulley	1	
31	GB/T 5783-2000	螺栓 M6×25	Bolt M6×25	1	
32	FJ100-040002-0000	定位板弹簧	Spring	1	
33	FJ100-040300-0000	定位板组合	Locating plate	1	
34	GB/T 5783-2000	螺栓 M6×20	Bolt M6×20	1	

五. 左右曲轴箱、变速机构、曲轴、活塞

CRANKCASE, GEARSHIFT, CRANKSHAFT, PISTON

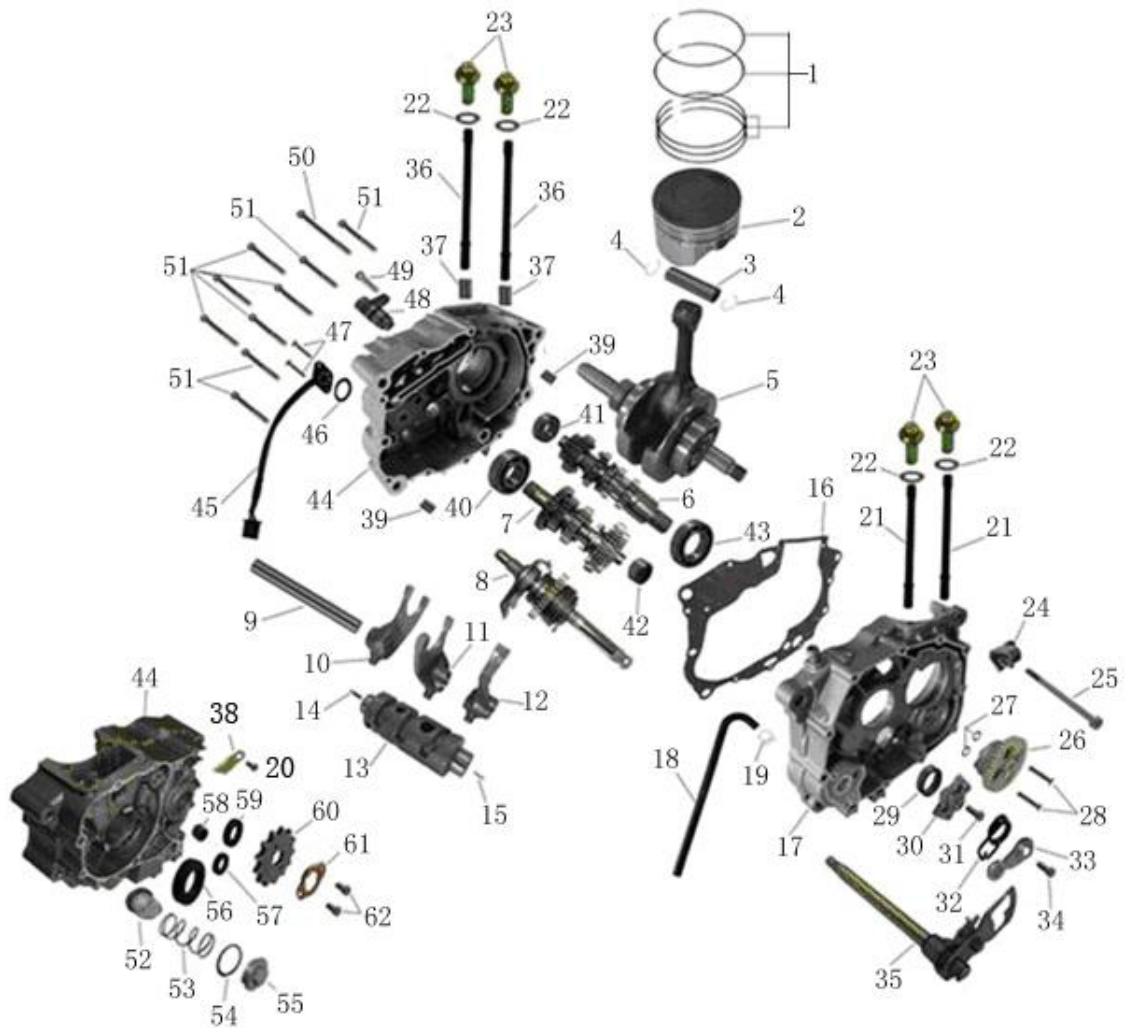

序号 RefNO	编号 Part No	零部件名称 Chinese Description	英文名称 English Description	数量 Qty	备注 Remark
35	FJ100-044000-0000	变档轴部件	Gearshift comp	1	
36	FN200-030004-0000	汽缸螺栓 B M8×142	Bolt B M8×142	2	
37	FJ100-000001-1014	定位销 φ10×14	Pinφ10×14	2	
38	FJ100-030027-0000	压线板	Plate	1	
39	FJ100-000001-1014	定位销 φ10×14	Pinφ10×14	2	
40	GB/T 276-1994	轴承 6204/P6	Bearing 6204/P6	1	
41	GB/T 276-1994	轴承 6202-Z	Bearing 6202-Z	1	
42	GB/T 290	滚针 NK15/23/12	Needle NK15/23/12	1	
43	GB/T 276-1994	轴承 6206/P6	Bearing 6206/P6	1	
44	FJ100-032002-0000	左曲轴箱部件	Left crankcase comp	1	
45	FJ100-032201-0000	档显组合	Gear monitor assy	1	
46	Q/HSQ 7757-2003	O型圈 φ19×2.2	O-ring φ19×2.2	1	
47	GB/T 818-2000	十字圆头螺钉 M4×18	Bolt M4×18	2	
48	FJ100-032100-0000	压销体组合	Pressing pin	1	带 O 形圈 13×2.5
49	GB/T 5783-2000	六角螺栓 M6×25	Bolt M6×25	1	
50	Q/HSQ 5787-2003	带盘螺栓 M6×95	Bolt M6×95	1	

51	Q/HSQ 5787-2003	带盘螺栓 M6×50	Bolt M6×50	9	
----	-----------------	------------	------------	---	--

五. 左右曲轴箱、变速机构、曲轴、活塞

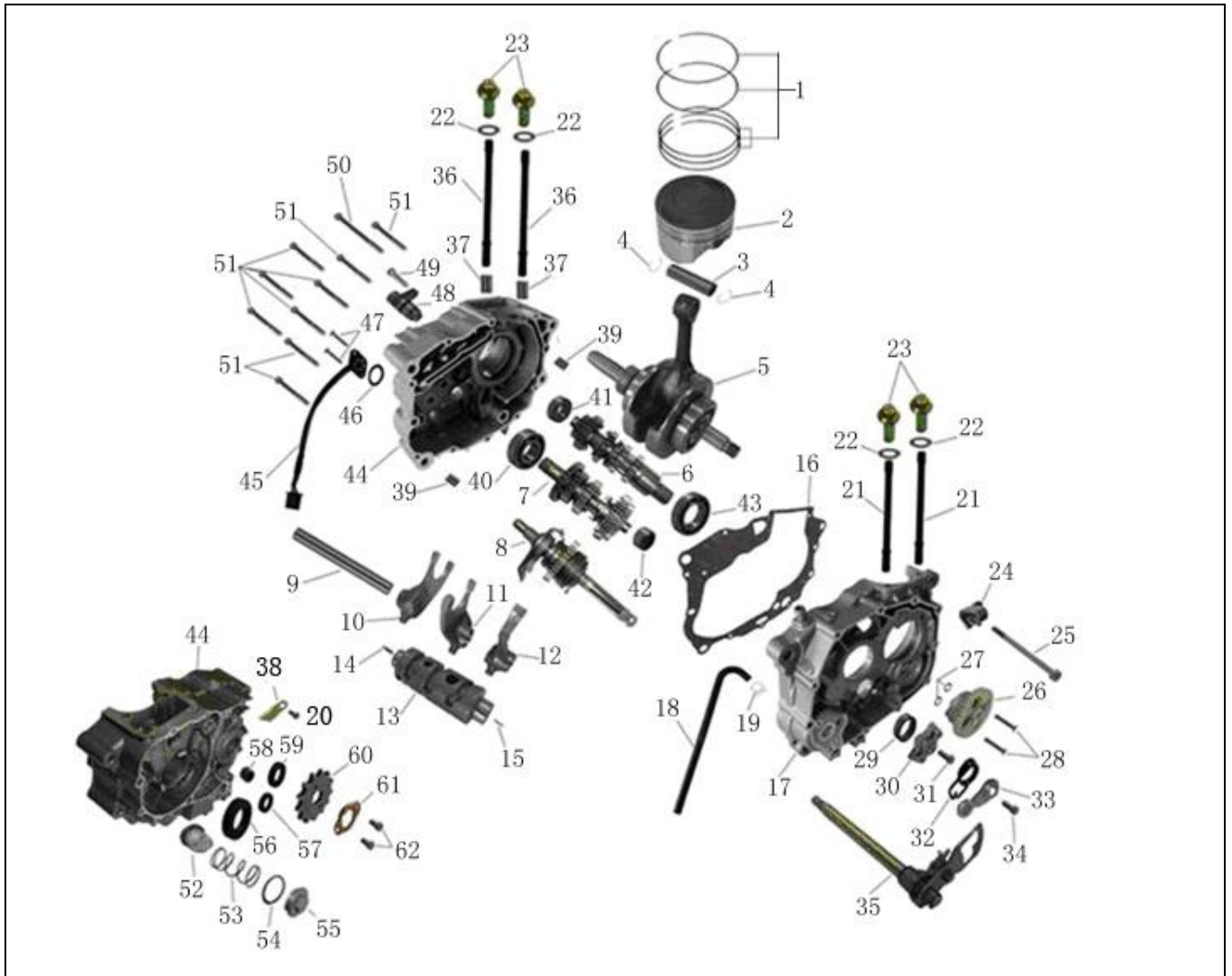

52	FJ100-030010-0000	机油滤网组合	Oil filter comp	1	
53	FJ100-030019-0000	机油滤网弹簧	Spring, oil filter	1	
54	Q/HSQ 7757-2003	O型圈 $\phi 35 \times 3$	O-ring $\phi 35 \times 3$	1	
55	FJ100-030043-0000	机油滤网盖	Cover, oil filter	1	
56	Q/HSQ 546-2007	曲轴油封 $34 \times 50 \times 7$	Oil seal $14 \times 50 \times 7$	1	
57	Q/HSQ 546-2007	换挡轴油封 $14 \times 28 \times 7$	Oil seal $14 \times 28 \times 7$	1	
58	GB/T 290	滚针 HK10/14/10	Needle roller HK10/14/10	1	
59	Q/HSQ 546-2007	副轴油封 $20 \times 34 \times 7$	Oil seal $20 \times 34 \times 7$	1	
60	FJ100-040004-0000	主动链轮	Driving sprocket	1	
61	FJ100-040005-0000	链轮压板	Pressing protector, sprocket	1	
62	GB/T 5783-2000	六角螺栓 M6×10	Bolt M6×10	2	