



MEDICAL 7

INFRARED SAUNA

FOR INDOOR USE ONLY

PRODUCT MANUAL



HOW-TO VIDEOS

To make things easier for you we provided these easy-to-follow instructional videos that will help you set up and use your new Medical Sauna™.

Note: On the next page, we included a list of Frequently Asked Questions. Please read them because they will answer most questions you may have.

▶ **HOW TO INSTALL THE MEDICAL SAUNA 7**

We understand most people do not like reading manuals, so we made a video that will show you how to install the Medical Sauna 7. Please go here to watch the video that will show you step-by-step how to install the Medical Sauna 7.

www.medicalsaunas.com/medinstall.php

▶ **HOW TO USE THE MEDICAL SAUNA 7**

The Medical Sauna 7 is very easy to use. There are only a few buttons on the remote, but the first time you use it might be overwhelming. So we made a video that shows what each button does. With this YouTube video, you can rewind it and play it back if you miss anything. You may have a lot of questions the first few times you use the Medical Sauna 7, but if you use this video as a reference guide for a few weeks, you will know everything about the sauna.

www.medicalsaunas.com/meddemo.php

**The videos and FAQ's will answer most questions. But, if you have further questions, feel free to contact us directly at www.medicalbreakthrough.org/contact-us.php*

***We are open 10AM-5PM PST (California Time). Thank you again for purchasing the Medical Sauna 7.*



FREQUENTLY ASKED QUESTIONS

These are the most commonly asked questions we get from our customers. Please read these questions and you'll have a better understanding of the Medical Sauna 7 in no time.

1. If I have questions and need some help who do I call?

Our customer support and tech team is open Monday to Friday 10AM to 5PM PST (California Time). The chair is very easy to use, the first time you use it, you might have a lot of questions, but after a few weeks you will know the chair very well. Just play around with the settings on the chair and after a while you will understand every button. If you have questions, we are here to help. Please call (661) 775-4866 Monday to Friday. Remember, we are in California, so please call when we are in, which is 10AM to 5PM PST.

2. What is the difference between a traditional sauna and an infrared sauna?

A traditional sauna heats up when you pour water over hot rocks, which creates steam. Infrared heat is more gentle. The experience is similar to lying in the sun on a warm day and feeling the heat radiate to the core of your body. Unlike traditional saunas, which operate around 200°F, infrared heat operates at a comfortable temperature of 100°-150°F. Both have unique health benefits, so it really depends of what you prefer.

3. What does a “full spectrum” sauna do?

Most infrared saunas only offer heaters that release infrared waves near one end of the spectrum. Our saunas offer a full spectrum of wavelengths: near, mid, and far infrared. A full spectrum heater is important because each spectrum of infrared waves provides different levels of skin penetration and light therapy. This means that you will get even more benefits in your sauna session and will truly start to feel more relaxed and healthy.

4. What are hybrid saunas?

Hybrid saunas have both traditional and infrared sauna features. Luckily, you do not need two different saunas anymore. We spent years developing the world's first hybrid saunas, allowing you to enjoy the benefits of both sauna experiences without having to choose.

5. How do I adjust the heat in the sauna?

To adjust the heat in the sauna, look toward the top of the controller where it states “Temperature Setting.” Pressing the “+” button on the left will increase the temperature by five degrees and pressing the “-” button on the right will decrease the temperature by five degrees. Holding the button down will change the temperature more quickly. Play around with it until you find your perfect temperature.

6. How do I adjust the time in the sauna?

To adjust the time for a sauna session, look toward the middle of the controller where it states “TIME.” Pressing the “+” button on the left will increase the time by one minute and pressing the “-” button on the right will decrease the time by one minute. Holding the button will change the time more quickly. The time can vary from 1 minute up to 60 minutes.

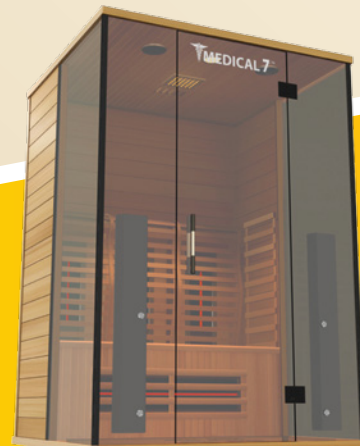

FREQUENTLY ASKED QUESTIONS (FAQs)

7. How long does it take for the sauna to heat up?

It depends on the temperature of the environment the sauna is in. In colder environments, the sauna will take longer to heat up. A room that is around 70°F or warmer would be best for a quicker heating. However, on average, the sauna will take 40 minutes to an hour to fully heat.

8. What material is the sauna made out of?

Our saunas are made of hemlock wood, which is excellent at retaining the heat inside of a sauna. Compared to other woods, hemlock is less likely to split and has less of a harsh aroma when in use. Hemlock is also naturally non-allergenic.

9. Are the sauna heaters ceramic or carbon fiber?

Our sauna heaters are made of carbon fiber. Ceramic heaters have shorter wavelengths when compared to carbon fiber. Carbon fiber heaters also has better, more even heat distribution, are more durable, and more energy efficient.

10. Can I set up my sauna outside?

Yes, you can set up your sauna outside, but you need a customized sauna cover, which you can get directly from Medical Saunas. Our heavy duty cover will fit your sauna perfectly and will ensure it is well protected from rain, sunlight, and other environmental factors that can damage the exterior of the sauna.

11. What are some safety precautions I should take before using the sauna?

You should always make sure to drink plenty of fluids before and after a sauna session. It's a good idea to do light exercise before entering a sauna so your body will more easily adjust to the inside of the sauna. If at any time you feel dizzy, nauseous, or any discomfort, exit the sauna immediately. When your sauna session is over, turn the power off, and sit in the sauna with the door ajar to allow your body time to adjust to the cooler air temperature. If you are new to saunas, your first session should be 10 minutes. Increase the time gradually with each session to condition your body. It is recommended to consult your physician before using a sauna.

12. What kind of maintenance is recommended for this sauna?

To get the best sauna experience, it is recommended that you clean your sauna regularly (weekly or biweekly) with fresh water and a gentle detergent. To prevent the interior from becoming overly dirty, you should use a towel to sit on while using the sauna. Occasionally (once or twice a year), you should use fine-grain sandpaper to smooth out the wood interior, making it look brand-new again. Gentle soap and water can also be used on the floor and exterior of the sauna.

13. What are the benefits of regular sauna use?

After decades of studies and research, saunas have been shown to provide a variety of health benefits. By improving blood flow, saunas are able to relieve aches and pains, leaving you feeling refreshed. After regular use, saunas can lead to more radiant skin and improved physical endurance. The greatest benefits involve reducing stress and improving cardiovascular health. Try using your sauna as often as you can and you'll feel the numerous benefits it offers.

14. What kind of power do I need for the sauna?

Our saunas require a 110v dedicated circuit that is rated up to 25amps depending on your sauna model. We recommend using a licensed electrician to install the sauna to avoid issues and ensure everything is done correctly.

15. What do I do if I have trouble installing the glass door of the sauna?

If you are having problems getting the sauna's glass door to align properly, there is an easy fix. All you would need is a small, plastic shim, which you can find on Amazon or Home Depot for \$1. There is a groove at the bottom of the door, near the hinge. Insert a small, plastic shim there to keep the door evenly levelled. To make it easier for you, we made a video to demonstrate:

www.medicalsaunas.com/glassdoor.php



Thanks for purchasing our products. To use these products safely and effectively, please read this manual carefully before use. We reserve the right to change this manual and improve our products.

TABLE OF CONTENTS

Table of Contents -----	1
Preparation -----	2
INSTALL ELECTRICITY BOX	
Powerbox indicator -----	3
Parameter -----	3
INSTALLATION	
Parts drawing -----	5
Installation drawing-----	6-9
OPERATION INSTRUCTION	
Controller indicator -----	10-12
AFTERSALES SERVICE	
Warning -----	13
Usage Notice -----	13
Reminder -----	13
Maintenance -----	14
Trouble Shooting -----	14



PREPARATION / PARTLIST

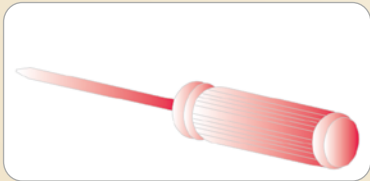

Screwdriver

(Using a power screwdriver is recommended)



3m

Tape Measure



8mm

Hexagonal Wrench

1. Check the quantity of components according to packing list or parts list.
2. Check if there is damage on the surface of product components or not.
3. Our saunas require a 110v dedicated circuit that is rated up to 25amps.
4. A professional or an electrician is needed when installing electrical components.

If you can not satisfy the above conditions, please stop installing immediately and contact the dealer.



INSTALL ELECTRICITY BOX

▶ Powerbox Indicator

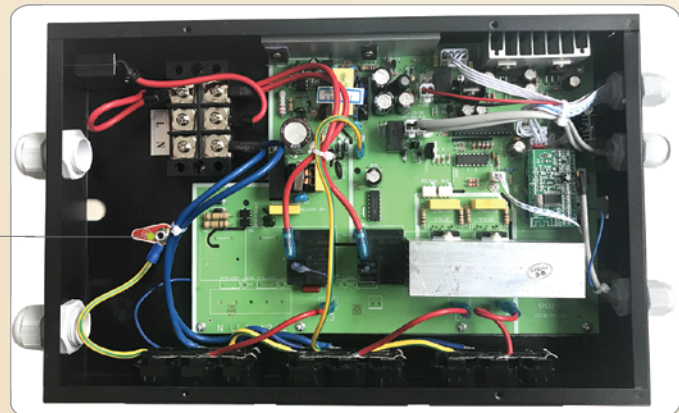
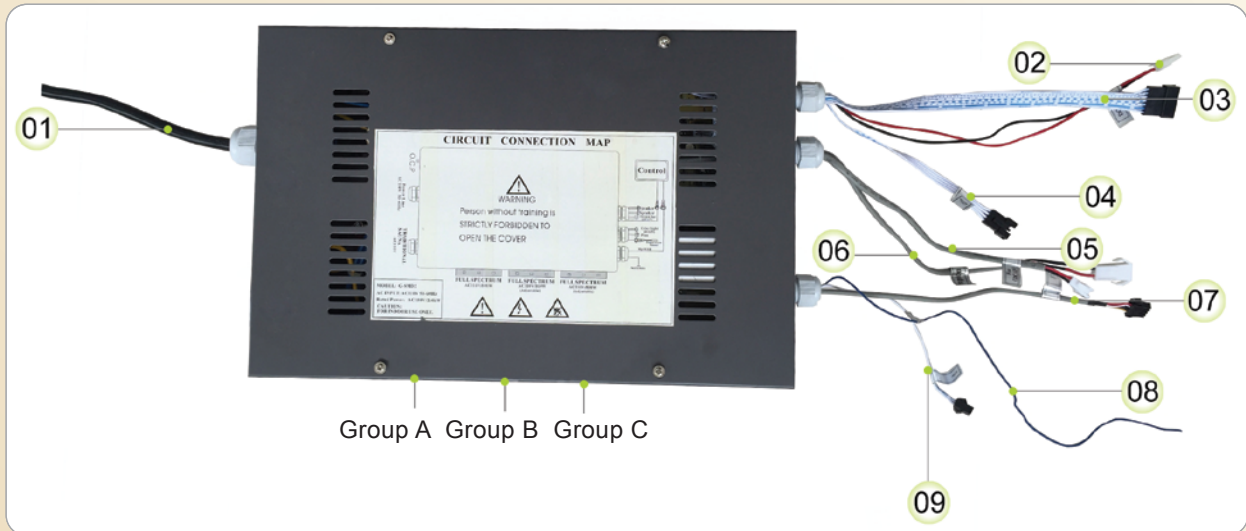

- ① **Main Power Supply**
- ② **Oxygen Ionizer**
- ③ **7P Signal Wire:** To get a signal for the control panel
- ④ **Speaker Wire:** connects to the left and right speaker
- ⑤ **Fan Wire:** Connects to the fan
- ⑥ **Colour Wire (optional):** Connects to the roof lamp
- ⑦ **USB Input:** for flashdrive or memory card
- ⑧ **The Antenna**
- ⑨ **Temperature Protector Wire:** To connect the temperature protector in the cabin (will not work connection is cut)

INSTALL ELECTRICITY BOX

The plug of electrical box and the load have different shapes with corresponding identification stickers, be sure to connect them properly.



PARTS DRAWING

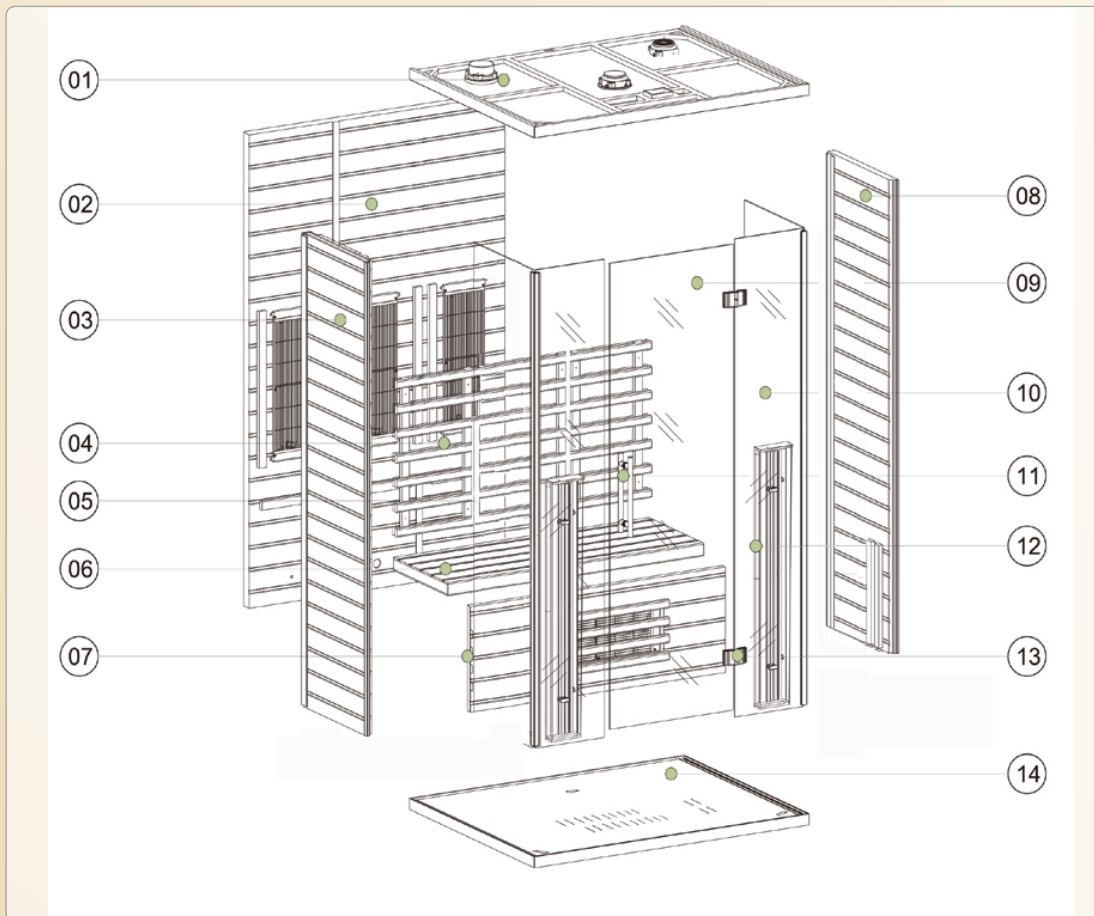

No.	Part Name	Quantity
①	Top board	1
②	Back board	1
③	Left board	1
④	Back barrier	1
⑤	Side fixed glass	2
⑥	Seat	1
⑦	Seat holder	1
⑧	Right board	1

No.	Part Name	Quantity
⑨	Glass door	1
⑩	Front fixed glass	2
⑪	Handle	1
⑫	Heater group	2
⑬	Hinge 1# (Right)	2
⑭	Floor	1

INSTALLATION DRAWING

▶ Step 1

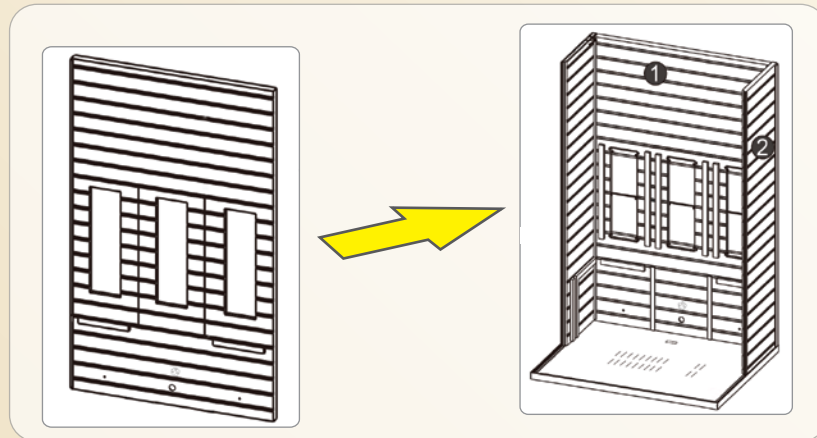

▶ Step 2

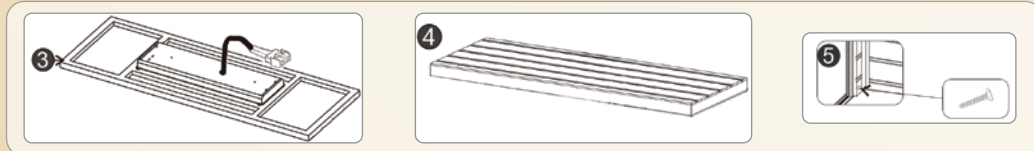
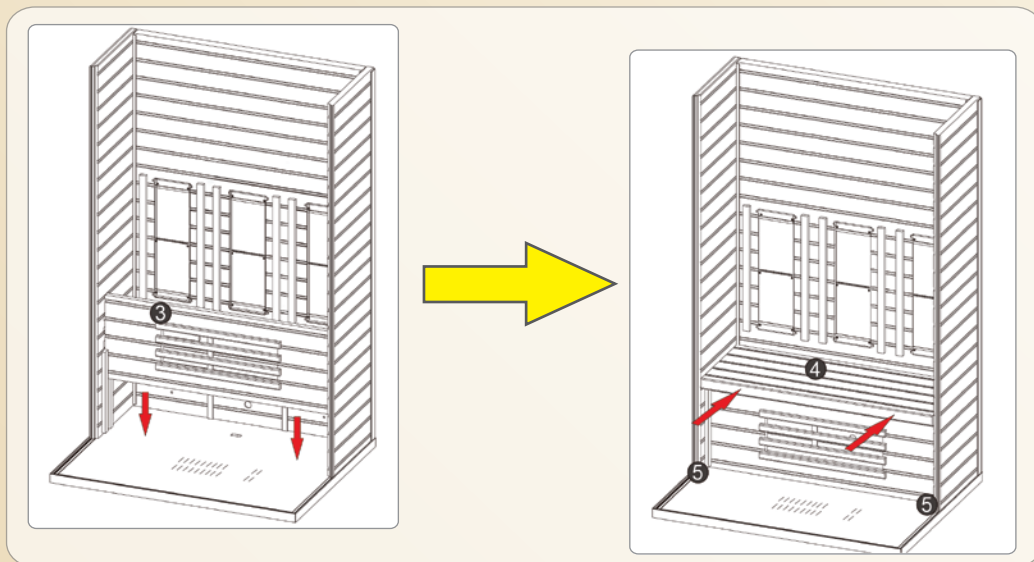

 **Note:** When you lock the screws **5** of step 2, pull the panel inward!

INSTALLATION DRAWING

▶ Step 3

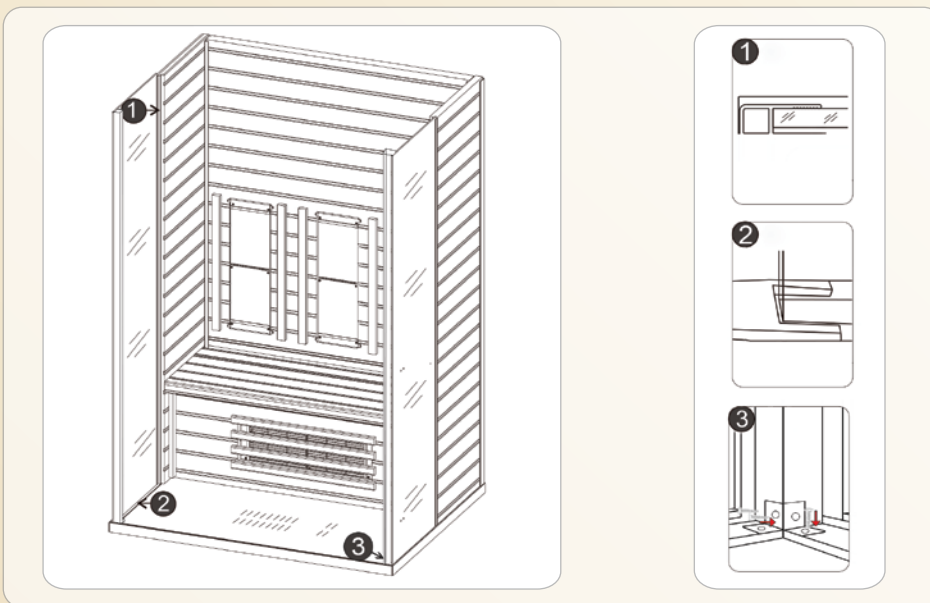

▶ Step 4

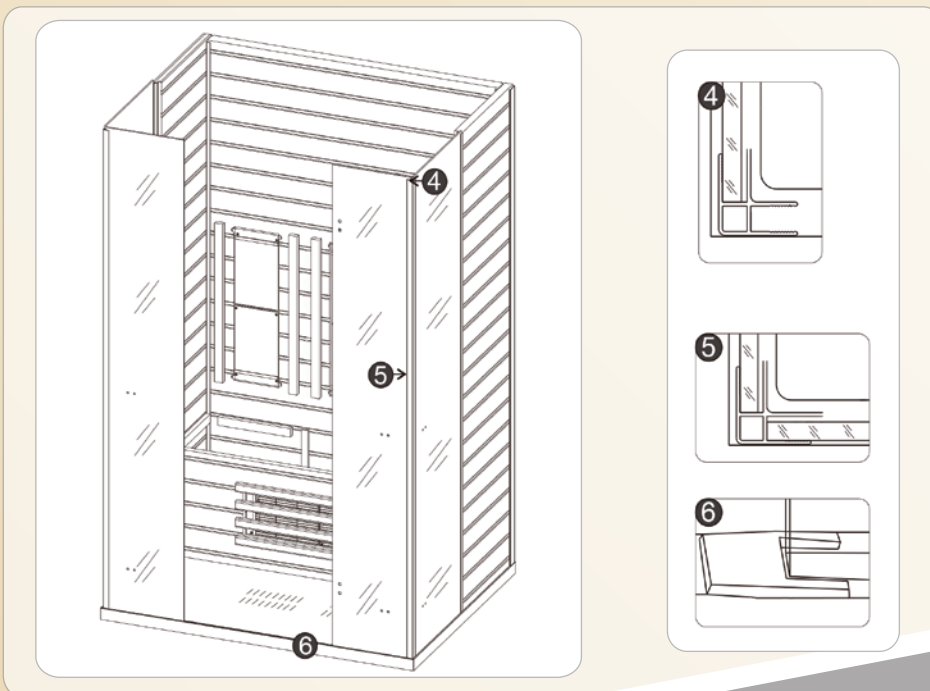

INSTALLATION DRAWING

▶ Step 5

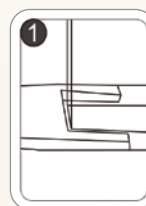
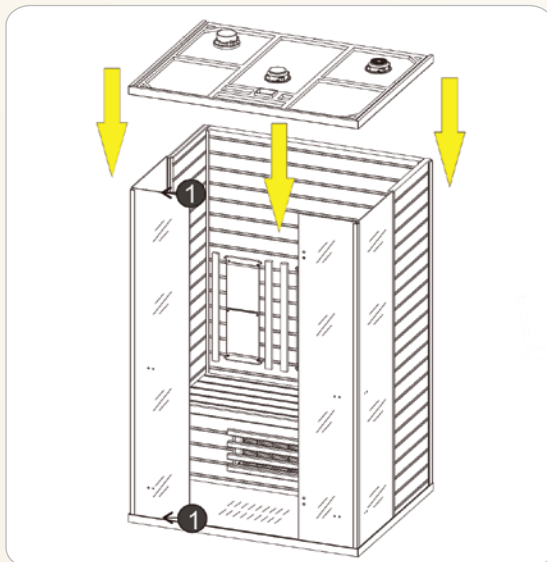

▶ Step 6

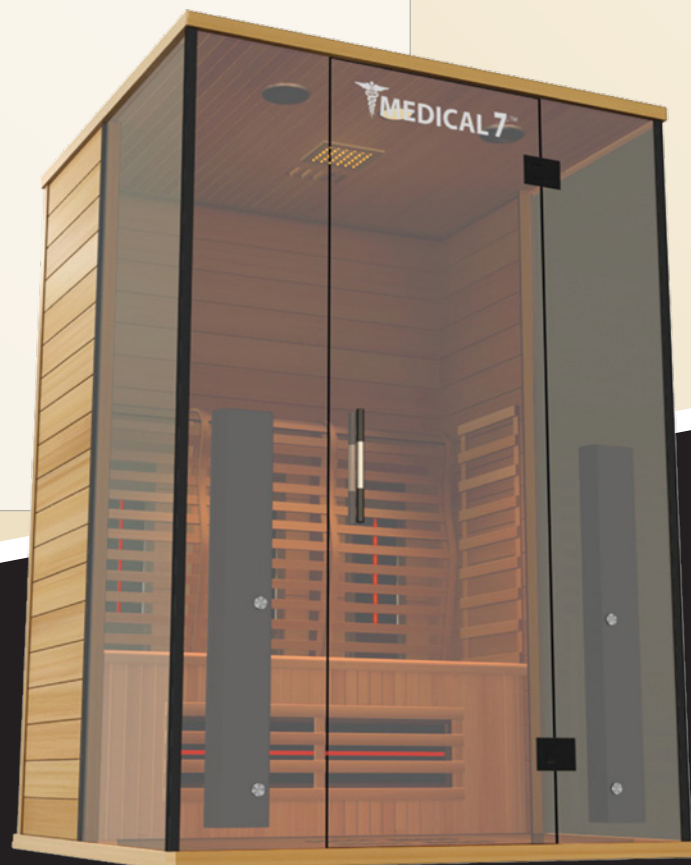
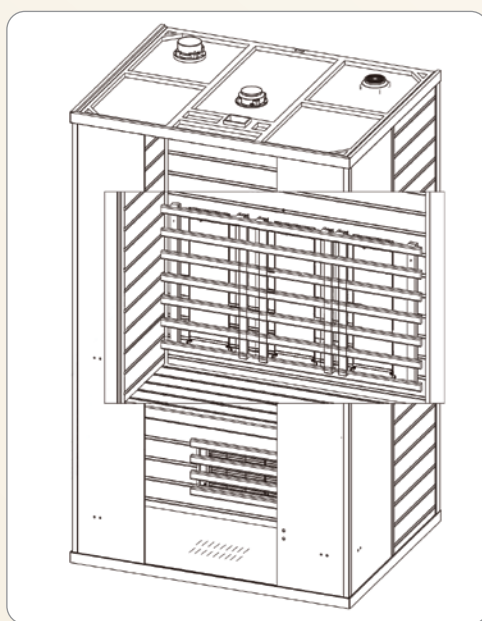

INSTALLATION DRAWING

▶▶ Step 7



please note when you lock the screws **2** of step 7, let another person pull the top panel downwards!

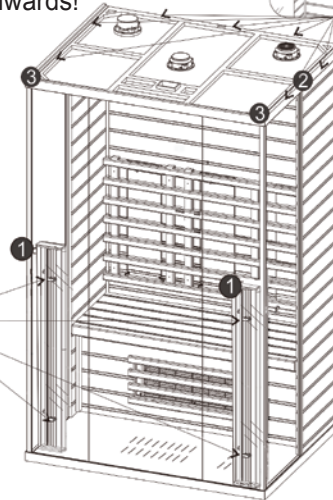
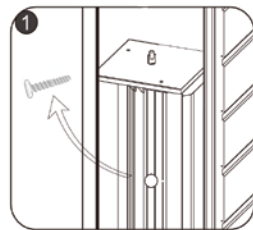

▶▶ Step 8

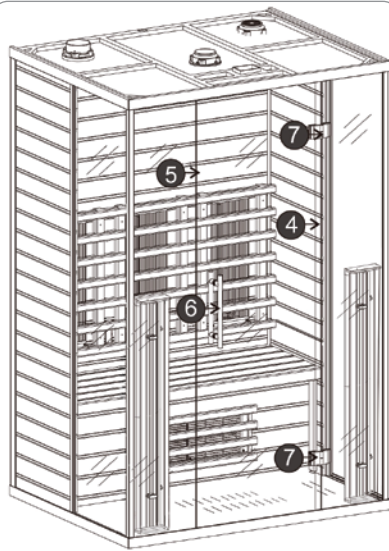

Please note:
When the glass door is installed, gently push and pull the door to ensure the hinges are installed properly

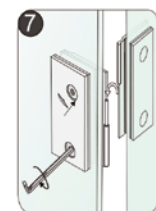
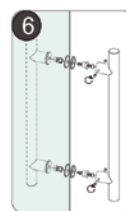
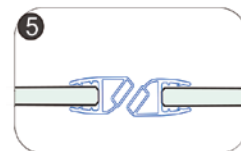
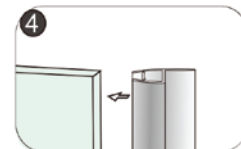

Note: Before installing the glass door, double-check steps 3 and 7 to make sure all screws are securely fastened.

OPERATION INSTRUCTION

▶ Controller Indicator

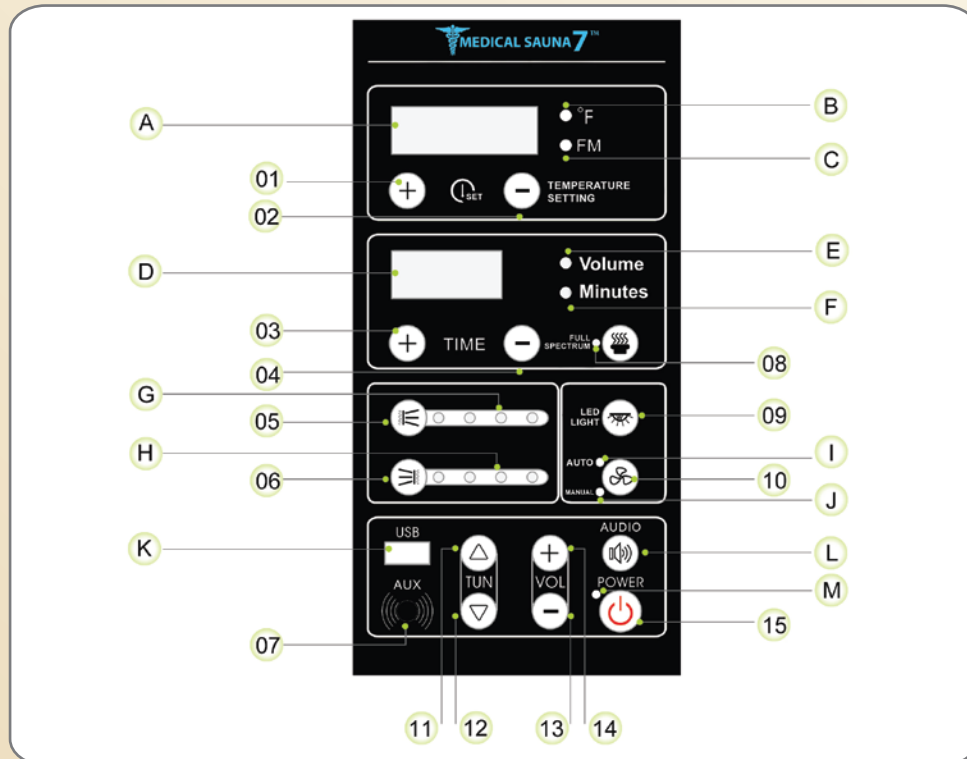

▶ Key

- | | | |
|---------------------------|--------------------------------|----------------|
| ① Temperature+ | ⑦ CD/MP3 input | ⑬ Volume+ |
| ② Temperature- | ⑧ Full spectrum infrared sauna | ⑭ Volume- |
| ③ Time+ | ⑨ LED light | ⑮ Power on/off |
| ④ Time- | ⑩ Fan | |
| ⑤ Infrared saunas group A | ⑪ FM frequency+ | |
| ⑥ Infrared saunas group B | ⑫ FM frequency- | |

▶ Display Areas

- | | | |
|-------------------------------------|------------------------------------------|--------------------------------|
| ① Temperature/FM | ⑥ Time setting indicator light | ④ Manual fan indicator light |
| ② Temperature indicator light | ⑦ Infrared sauna group a indicator light | ⑤ USB |
| ③ FM tuning indicator light | ⑧ Infrared sauna group b indicator light | ⑥ Music |
| ④ Volume/time | ⑨ Automatic fan indicator light | ⑦ Power on/off indicator light |
| ⑤ Volume adjustment indicator light | | |



OPERATION INSTRUCTION

▶ 1. Turn on/ Turn off

When the sauna is powered on, the power light indicator will turn on. Press it to turn the sauna on. Press the button “full spectrum” and the sauna will turn on.

▶ 2. Time/ Temperature setting

When the sauna is powered on, pressing the time+ or time- button will increase or decrease the time by one minute. Holding down either time button lets you to change the time more quickly. Time can vary between 1-60 minutes.

When the sauna is powered on, pressing the temperature+ or temperature- button will increase or decrease the temperature by five degrees. Holding down either temperature button lets you to change the temperature more quickly. Once your desired temperature is reached, the sauna will stop heating. When the temperature inside the sauna lowers, it will begin reheating automatically.

▶ 3. Multi-color therapy/ LED light

The multi-color therapy is controlled by the remote controller. Select any color buttons and the multi-color therapy will turn on. Press the power button to turn multi-color therapy off. The LED light is controlled by the key on the control panel.

▶ 4. Fan function

When the sauna is powered on, press the fan key to turn on the fan. When the fan is in auto mode, the sauna will stop heating and start using the fans.



OPERATION INSTRUCTION

▶ 5. Audio Function

The AUDIO button allows you to switch between audio functions.
Pressing the AUDIO button the 1st time will turn on the Bluetooth function.
Pressing the AUDIO button a 2nd time will turn on the USB function.
Pressing the AUDIO button a 3rd time will turn on the Radio function.
Pressing the AUDIO button a 4th time will turn on the AUX function.
Pressing the AUDIO button a 5th time will turn off the voice function.



OPERATION INSTRUCTION

▶ **WARNING**

1. Product protective grade :IP20. Do not use it outdoors or in a humid room.
2. For safety, don't change the electrical equipment. If there is any problem, please ask a professional to fix it.
3. Do not touch the heater surface once infrared is turned on.
4. Do not use the product if are prone to bleeding, have open wounds, or suffer from heart disease and/or cardiovascular disease. Consult a doctor before use.
5. Any child or person suffering from a disability must have appropriate supervision before using the product.
6. Do not put anything flammable (i.e. towels, clothes, etc.) near the heaters.
7. Do not use tap water to wash the cabin.
8. Make sure the power is off when cleaning the cabin or fixing/replacing the parts.
9. Use caution when adjusting the volume on the speakers as high frequencies may damage the system.
10. Ensure the power cable is grounded reliably.
11. Pay attention to the rated voltage and power supply, if they do not match, then they cannot be used. Otherwise, it can damage the controller.

▶ **NOTICE**

1. The ideal usage time is 30 minutes. The control system set time is 40 minutes.
2. The suitable temperature is 110-120 F, please adjust the heater's temperature to match your needs.
3. Remove the power cable after use.
4. Make sure wires and sockets are securely connected before turning on the power.
5. After using for two cycles (~60 minutes), turn off the heater for at least 30 minutes.

▶ **REMINDER**

1. In order to maintain the quality of the product, wait at least 30 seconds between cycles.
2. The control system continues to work even after turning off the heater or multi-color lamp. The best way to ensure the power is off is to unplug the sauna.
3. If a child is using this product, make sure they are not too close to the infrared lights so they are not injured.
4. In case of an accidental shutdown, wait for a minute, then restart.
5. If you experience any discomfort, turn off the power.
6. Before use, it is good to have something to drink (i.e. mineral water, fruit juice, vegetable juice, etc.). After use, it is good to have a bath or shower with water that is not too cold.

CIRCUIT DRAWING

▶ MAINTENANCE

1. Use a general neutral liquid detergent to clean the product surface (surface contains: bamboo, composite boards, plastic, aluminum, plated and sprayed parts). Do not use strong alkaline cleaners or solvents (i.e. alcohol, thinner, ammonia, acetone, etc.).
2. Use a soft cloth to clean chrome-plated pieces, never use rough tools.
3. Use fine sandpaper to polish wood surfaces if the surface is scratched or scraped.
4. Regularly open the door or window of the sauna to avoid mildew buildup.

▶ TROUBLE SHOOTING

Problem	Reasons	Remedy
No power	<ol style="list-style-type: none"> 1. Poor power connection 2. Power failure of the leakage switch 3. The fuse is off or damaged 	<ol style="list-style-type: none"> 1. Make sure the power cable is connected 2. Reconnect the leakage switch 3. Replace the fuse
No infrared	<ol style="list-style-type: none"> 1. The permanent temperature detector is off 2. The heater plug is not well connected 3. Infrared tube/board is damaged 	<ol style="list-style-type: none"> 1. Turn the temperature off, then try again 2. Reconnect the power cable 3. Replace the infrared tube/board
No sound	<ol style="list-style-type: none"> 1. The volume is turned off or is too low 2. The multicolor lamp supply cord is not well connected 3. The speaker is damaged 	<ol style="list-style-type: none"> 1. Adjust the volume 2. Reconnect the supply cord 3. Replace the speaker
No color light	<ol style="list-style-type: none"> 1. The sauna is turned off 2. The multicolor lamp supply cord is loose 3. The multicolor lamp is damaged 	<ol style="list-style-type: none"> 1. Make sure the sauna is turned on 2. Reconnect the supply cord 3. Replace the multicolor lamp
No fan	<ol style="list-style-type: none"> 1. The fan is off or automatic 2. The fan supply cord is loose 3. The fan is damaged 	<ol style="list-style-type: none"> 1. Turn on the fan 2. Reconnect the supply cord 3. Replace the fan



Are your appliances running safely? Or do you trip a breaker each morning when you make your toast, putting added strain on other kitchen appliances? If this is a frequent occurrence in your home, your appliances may not be wired properly. Dedicated circuits are required by the National Electrical Code for major electrical appliances such as refrigerators, stoves, washers, dryers, space heaters, and more. They ensure enough power is available so that appliances can operate safely, without overloading the system.

What is a dedicated circuit?

A dedicated circuit is set aside with a specific purpose, with its own circuit breaker in your electrical box. A dedicated circuit is intended for use with a single appliance only. No other appliances will be plugged into or utilize the energy from this circuit, making it “dedicated” to that single appliance. Dedicated circuits ensure major appliances that draw a lot of electrical current are able to access the energy they need without overloading your system, blowing a fuse or tripping a circuit breaker. Certain medium to heavy duty appliances may require a dedicated circuit:

20 amp

For mid-range items, like hair dryers and toasters.

30-50 amp

For heavy duty appliances like dryers. These breakers typically offer “double pole” protection to prevent the circuit from drawing too much power, possibly resulting in a fire.

A diagram of dedicated circuits in a home.

Why are dedicated circuits important for my home?

Dedicated circuits protect your appliances, your family, and your home.

Appliances without a dedicated circuit may draw more current than the circuit can handle, tripping breakers, blowing fuses, and overheating wire insulation causing breakdown and the possibility of electrical fires.

Appliances that are wired to a dedicated circuit with incorrect wire size and insufficient amperage for their needs may get overheated possibly resulting in a fire. Trust the professional electricians at Mr. Electric® to ensure your appliances are wired safely and correctly.

How do I know if I need a dedicated circuit installed?

The National Electrical Code requires that every fixed appliance be served by a separate, dedicated circuit, not shared with any other appliance. Breakers that are constantly tripping are a good indication of appliances in need of a dedicated circuit. If it has a motor, it typically requires its own circuit. Unsure? Contact a Mr. Electric professional for help.

Appliances that need a dedicated circuit include:

- Electric ranges
- Wall ovens
- Refrigerators
- Microwaves
- Freezers
- Dishwashers
- Garbage disposals
- Toasters
- Washers
- Dryers
- Space heaters
- Heating and air conditioning units
- Furnaces
- Water heaters
- Garage door openers
- Sump pumps
- Water pumps
- Central vacuums
- Whirlpools/Jacuzzis/hot tubs/saunas
- Blow dryers
- Specific areas of your home such as bathrooms, kitchen counter area, and garages

▶ TIPS FOR USING YOUR SAUNA

1. If you take a hot/warm shower or bath before using your sauna, you may perspire more and experience even more comfort.
2. Drink water prior to, during, and after your sauna session to replenish your body fluids.
To regulate the set temperature inside the sauna to your comfort level, use the movable roof
3. ventilation or leave the door open slightly, The roof ventilation is installed on the sauna and used based on personal preference.
4. Use 2 of 3 towels during your sauna session. Fold one of the towels several times and place it on the bench. The towel will absorb some of your perspiration while adding comfort as you sit on the bench.
Place another towel on the floor to absorb perspiration as it falls from your body. If your model sauna has a floor heat emitter, do not place any towels over the floor heat emitter. Use the additional towel to wipe perspiration from your body from time to time.
5. At the first sign of a cold or flu, increasing your sauna session may be beneficial in boosting your immune system and decreasing the reproductive rate of viruses.
6. To help relieve sore and tense muscles, massage the affected areas during your sauna session.
7. To treat your ankles and feet more effectively, you can elevate them and move them close to one of the heat emitters to achieve a deep heating effect.
8. To utilize the sauna's heat therapy effect, put oil of treatment into your hair and wrap it with a towel. After your sauna session is over, rinse your hair thoroughly. Please follow the product directions for the intended benefits.
9. The peaceful and relaxed state rendered by a sauna session may help you to sleep easier and deeper.
10. To conserve energy consumption, please unplug your sauna when not being used.
11. After the sauna session is over, do not jump into the shower or bath immediately. Because your body was heated up during the sauna session, it will continue to perspire even after the heat emitters are off. Sit in the sauna with the door open slightly and let your body cool down. Once your body has cooled down and you feel comfortable, you can exit the sauna. After about twenty minutes and when your body has completely cooled down, you can take a shower to rinse the perspiration off your body.

RESPONSIBILITIES OF OTHERS

- Unless otherwise expressly agreed in writing, In the event of a problem identified prior to installation, the unit must not be installed, and Company is not responsible for failures or damage that could have been discovered, repaired, or avoided by proper inspection prior to installation.
- Damage occurring in transit is the responsibility of the carrier.
- The user or installer **MUST** open the crate and inspect the unit for damage when it is delivered. If damage is discovered, it must be reported immediately to the seller and the carrier.
- Failure of the carrier to respond should be reported to the seller and the carrier. Your freight claims should be filed promptly thereafter.
- Damage occurring to the unit during installation is the responsibility of the installer, contractor or user, and damage occurring thereafter is the responsibility of the user. Failure of any non-factory installed components, parts and accessories is the sole responsibility of the user.
- Any replacement parts shall be covered only by the original equipment manufacturer warranty, if any. The Company is not responsible for costs to modify any product to obtain any code approval, such as city, county, or state building codes.
- Failure to abide by the instruction explicitly stated in the manual is the sole responsibility of the user.
- Damage to the installed equipment, or injury to any persons, as a result of, but not limited to, misuse, modifications, and negligence, is the sole responsibility of the user.





Manual Version 10.20