

catalogue /2021

fuse flooring

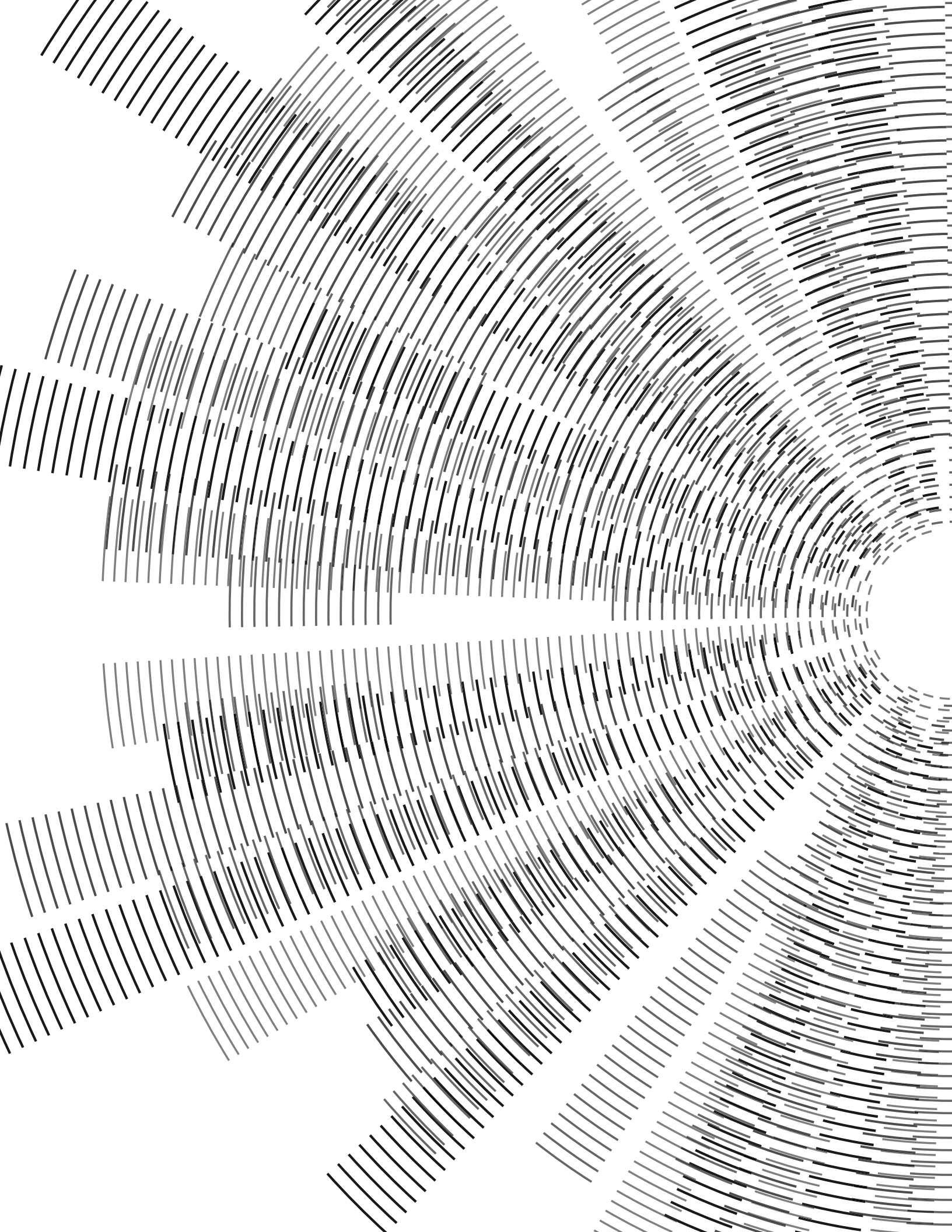

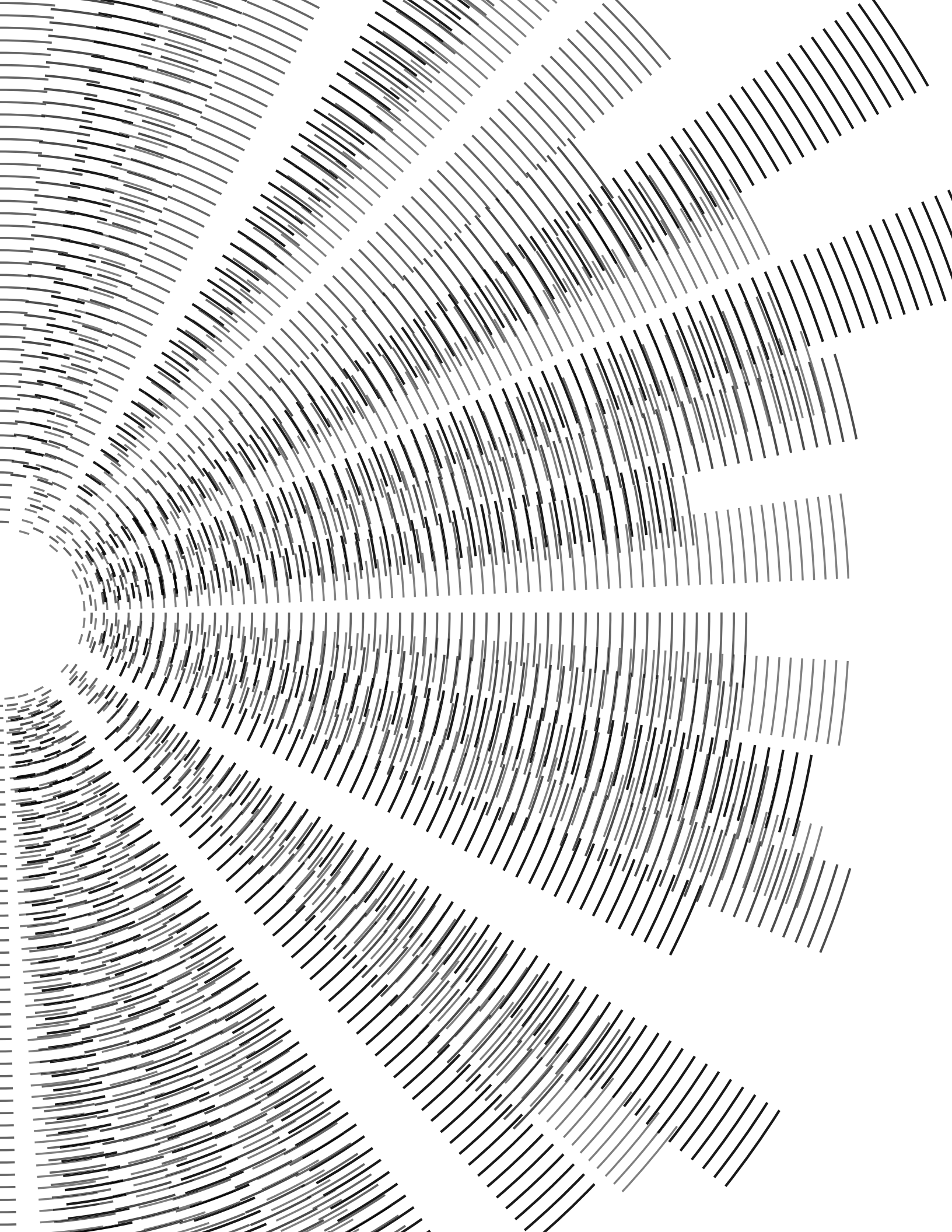

about

**enhancing the intrinsic
beauty of wood.**

Fuse Flooring is the result of an appreciation of nature - its ability to create and to inspire. We're moved by wood's uneven grain, its knots, and unpredictability. We want to enhance the intrinsic beauty of wood.

Our appreciation drives us to provide the best and most beautiful wood floors.

sustainability

Sustainable Materials

All wood in Fuse Flooring products comes from sustainably grown and harvested forests. The wood is fully certified on its journey from seed to board.

**certified real
wood**

Health Conscious

Materials and manufacturing are chosen to create a healthy product. Multiple certifications for low or no volatile organic compound (VOC) emissions ensure indoor air quality is not compromised.

Responsible Manufacturing

Products are made in Germany and Austria where strong labour laws ensure workers are paid fairly and work in safe environments.

Longevity

High quality products last longer and are replaced less frequently. Our floors' structural stability and refinishing options allow the floor to last for decades.

certifications

PEFC

The Programme for the Endorsement of Forest Certification (PEFC) is a global body that ensures sustainable forest management and prevents deforestation. It is similar and often considered equivalent to FSC.



Floor Score

A third-party certification indicating low to zero VOC emissions. All parts of the product are tested including the wood, finish, and adhesive.



Émissions Dans l'Air Intérieur A+

Measures total VOCs of 10 different substances for interior products. Class A+ is the lowest level of emissions that can be achieved.



CARB2 Compliant

The CARB 2 standard is a limitation on formaldehyde emissions. Created by the California Air Resources Board (CARB), their mandates are strict and the standard across the industry.



Real Wood

Certifies that the product is made exclusively from wood and not composite materials that may contain plastic or other synthetics.

flyt herringbone c

bass / perch / pla
bream / skate

ollection/

rice /

flyt herringbone

by fuse flooring

herringbone collection

Subtle colour variation brings life to the herringbone pattern. Named after fish who's scales inspired the pattern's name, the collection features five colours for traditional and contemporary spaces. Can be installed as a floated floor.

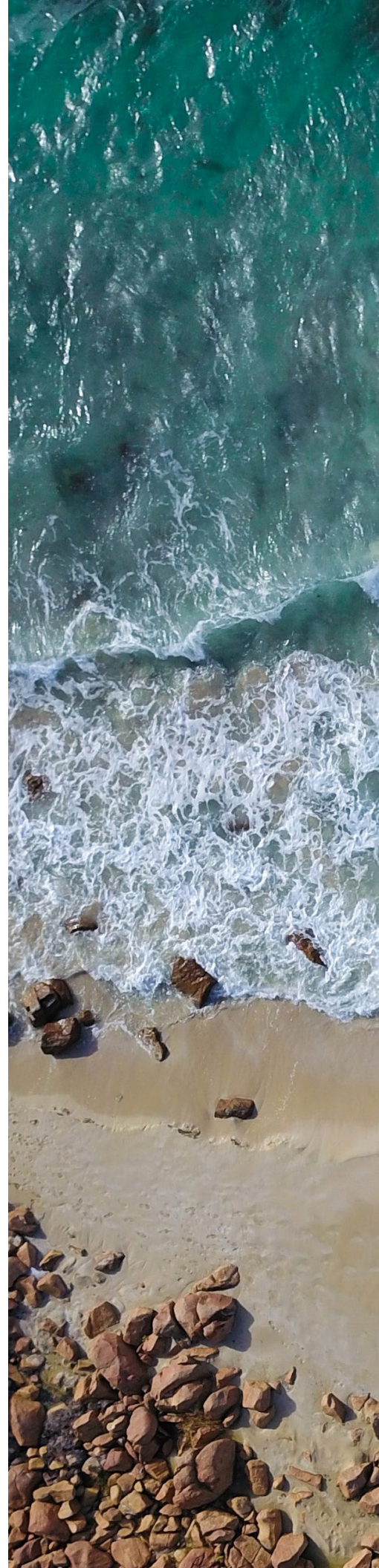







features

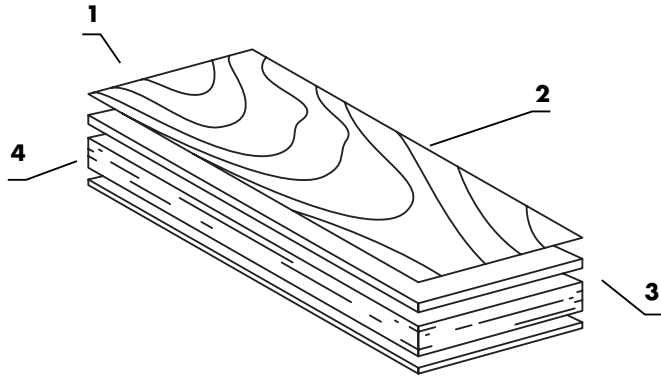

dimensions

13 H x 95 W x 570 L mm



1 / finish

Matte Bona Lacquer



2 / texture

Light Brush



3 / top layer

White Oak



4 / core

Quartersawn Spruce



installation

Glue Down or Float
Radiant Heat Compatible



herringbone assembly

Connection Drop and Lock ("click")
Bevel 4-sides

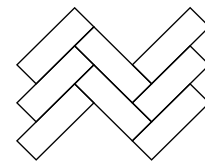

accessory options

Made from the same material as the floor
for a perfect match.

stairs

Full cladding: riser, tread, and nosing
Up to 2000 mm wide



vents

All wood, with damper. Two sizes:
76 W x 254 L mm
101 W x 254 L mm



nosing

Up to 2000 mm long
108 mm wide



flush reducer

Up to 2000 mm long
44 mm wide

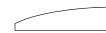

t-mould

Up to 2000 mm long
44 mm wide

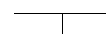



bass



perch



plaice





bream



skate



herringbone specs

1 / product

collection

Flyt

style

Herringbone

finish

Bona urethane

surface

Brushed

2 / construction

type

Engineered hardwood

layers

3-layer

edge

Bevel 4-sides

connections

Drop and lock ('click')

dimensions

13 H x 95 W x 570 L mm

3 / wood

species

White Oak

grade

Natural

treatment

Stained

cut

Flatsawn

hardness

1360 (Janka scale)

4 / layers

lamella

White Oak

thickness

Nominal 2.5 mm

core

Spruce

thickness

9 mm

backing

Spruce Ply

origins

Made in Austria or Germany

certifications

PEFC
 Floor Score
 Émissions Dans l'Air Intérieur A+
 CARB2 Compliant
 Real Wood







grade guide



select

Maximum size of sound knots	—	15 mm
Maximum size of open knots	—	Not allowed
Heart / Pith	—	Not allowed
Sapwood	—	Not allowed
End checks / End cracks	—	Not allowed
Small cracks	—	Not allowed
Colour Variation	—	Harmonic
Ingrown bark	—	15 mm



nature

Maximum size of sound knots	—	30 mm
Maximum size of open knots	—	15 mm
Heart / Pith	—	Not allowed
Sapwood	—	Not allowed
End checks / End cracks	—	Not allowed
Small cracks	—	Allowed / up to 100 mm long & 1 mm
Colour Variation	—	Harmonic
Ingrown bark	—	Not allowed

Hardwood grades are based on the size and number of clear pieces that can be obtained from a board.

Grades are not determined by gut reactions but actual measurements of clear sections and definitions for characteristics.



living / classic

Maximum size of sound knots	—	50 mm
Maximum size of open knots	—	25 mm
Heart / Pith	—	Not allowed
Sapwood	—	Allowed / 2 cm both sides or 4 cm one side
End checks / End cracks	—	Not allowed
Small cracks	—	Allowed / up to 100 mm long & 1 mm
Colour Variation	—	All colours
Ingrown bark	—	Not allowed



rustic

Maximum size of sound knots	—	80 mm
Maximum size of open knots	—	50 mm
Heart / Pith	—	Allowed
Sapwood	—	Not allowed
End checks / End cracks	—	Allowed / up to 400 mm long & 8 mm
Small cracks	—	Allowed / up to 1105 mm & 1 mm
Colour Variation	—	All colours
Ingrown bark	—	Allowed / up to 50 mm long & 3mm

