



DirectConnect®

DirectConnect®

Houston, Texas 77027

Phone 800 -531-3224

<http://www.directconnecthome.com>



Tilting LED/Plasma Mount



DCT3255V-RAC

INSTALLATION MANUAL

.30934



- DirectConnect® is a registered trademark
- UL is a registered trademark of Underwriters Laboratories

TV size range:	32" – 55"
Distance to the wall:	2.48" / 63mm
Maximum load capacity:	165lbs / 75kg
Universal VESA:	400 x 400
Max Tilt:	-10° ~ +10°

SAFETY WARNING

1. This DirectConnect® mounting bracket was designed to be installed and utilized ONLY as specified in this manual. Improper installation of this product may cause serious injury.
2. This product should be installed by someone with good mechanical ability who has experience with basic building construction and who fully understands this manual.
3. Make sure that the supporting wall surface will safely support the combined weight of the equipment and all attached hardware and components. Never exceed the Maximum Load Capacity.
4. If mounting to wood wall studs, make sure that the mounting screws are anchored into the center of the studs. The use of a stud finder is highly recommended.
5. Always use an assistant or mechanical lifting equipment to safely lift and position the equipment.
6. Tighten screws firmly, but do not over tighten. Over tightening can damage the items, this greatly reduces their holding power.
7. Check around the mounting location, there should be no cables, water lines or gas pipes, etc.
8. This product is intended for indoor use only. Using this product outdoors could lead to product failure and personal injury.
9. This product is only for wooden, brick, concrete walls or sheetrock.
10. DirectConnect® is not responsible for any personal injury or product damage due to mishandling, incorrect mounting, assembly, or use of this product.

Important:

If you do not understand these instructions completely, please contact your installation specialist.

6.0 Adjusting the TV Tilt

- To adjust the tilt of the TV, pull from the top of TV as shown below.
- To adjust the vertical height on each arm, use a Phillips head screwdriver and turn the screw to the desired position.
- Once the vertical height has been achieved, tighten the screws at the bottom of each bracket to lock the rail to the mount.

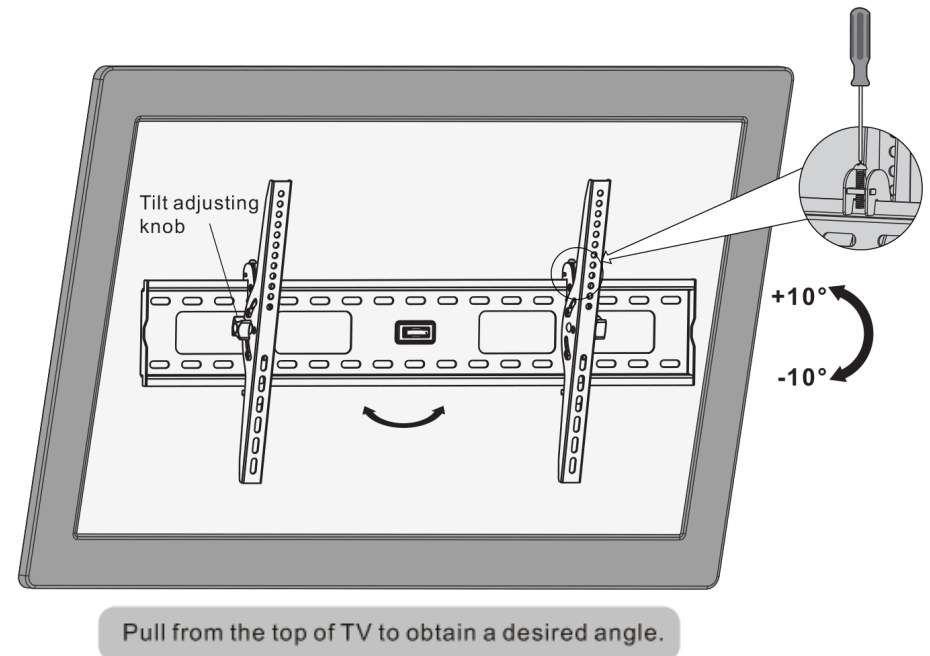

7.0 Specifications

Material:	Steel, Plastic
Product Size:	63X460x440mm
Recommended Screen Size:	32"-55"
Installation:	Solid Wall, Double Stud
Rated Weight Capacity:	165lbs/75kg
VESA Standard:	200x200, 400x200, 300x300, 400x400
Max.VESA:	400x400
Tilt:	-10 to 10°
Profile:	63mm/2.48"

4.0 Attaching the Adapter Brackets

1. Choose appropriate screws (M-A or M-B), washers (M-C) and spacers According to the type of screen.
2. Position the adapter brackets as close as possible to the center of the TV.
3. Screw the adapter brackets onto the TV as shown in fig. 4a.
4. Tighten all screws (Do not over tighten)

Fig 4a

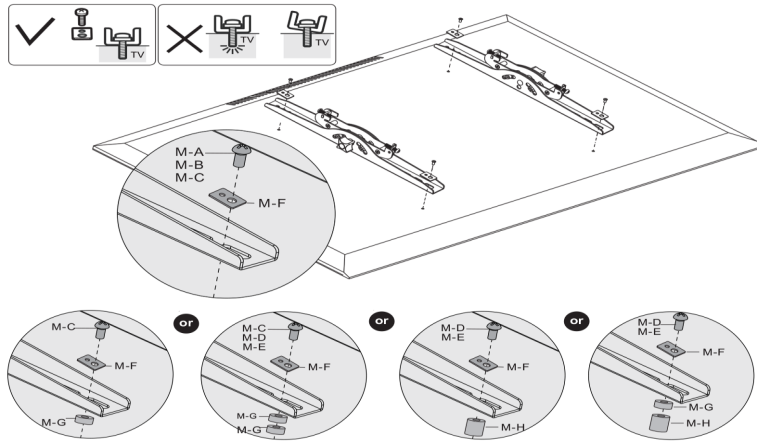

5.0 Hanging the TV onto the Wall Plate

- Always use an assistant or mechanical lifting device to safely lift and position the TV onto the wall bracket.

1. Lift the TV onto the wall plate. Make sure that the hooks on the adapter brackets latch onto the wall plate to avoid injury.
2. Once the TV is in its final position, tighten the bottom bolts to secure the adapter brackets to the wall plate.

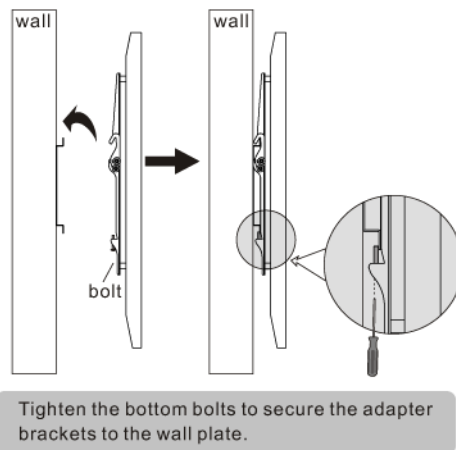

1.0 Hardware List

NOTE: Ensure that you have all the parts shown below prior to installation. The supplied wall mounting hardware is not for use on metal stud walls or cinder block walls. If you are uncertain about the nature of

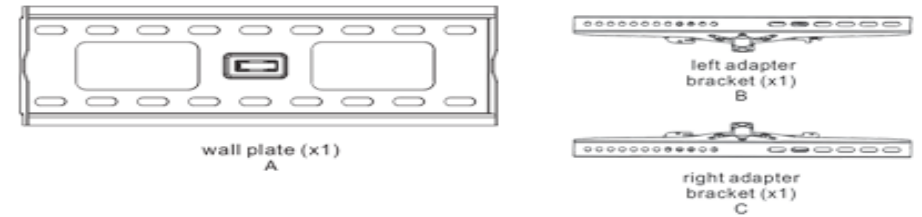

Package M

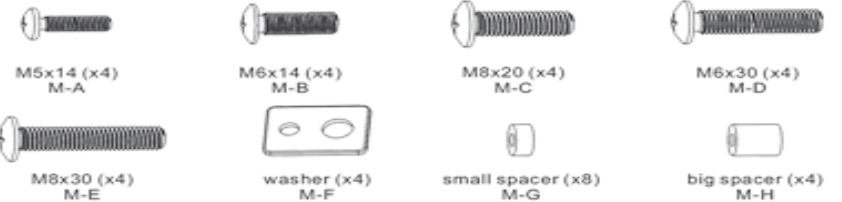

Package W



2.0 Line Drawing

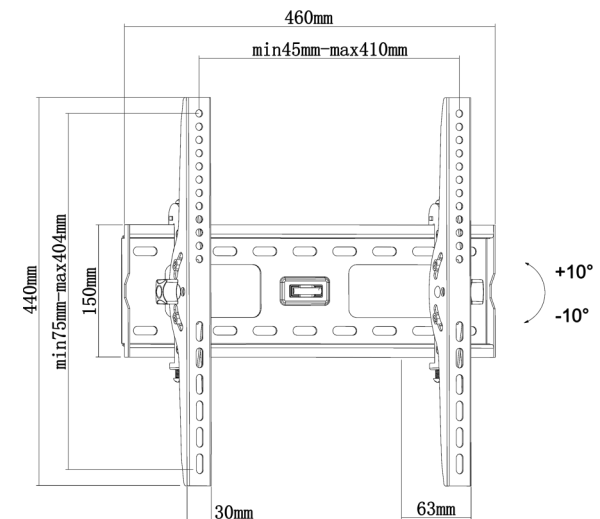

3.0 Wall Plate Mounting—Wood Studs

- Make sure that the mounting screws are anchored into the center of the studs. The use of a stud finder is highly recommended.
- DirectConnect® is not responsible for providing hardware for any type of installation other than what is shown.
- Verify that the supporting surface will safely support the combined weight of the equipment, hardware, and components.

1. Find and mark the exact location of mounting holes. Make sure wall plate is level prior to drilling holes using supplied level.
2. Drill pilot holes.
3. Use a 1/4" drill bit and drill into the stud 2" as shown in fig 3a.
4. Mount wall plate onto the wall using the supplied bolts and washers (W-A and W-C).

Fig 3a

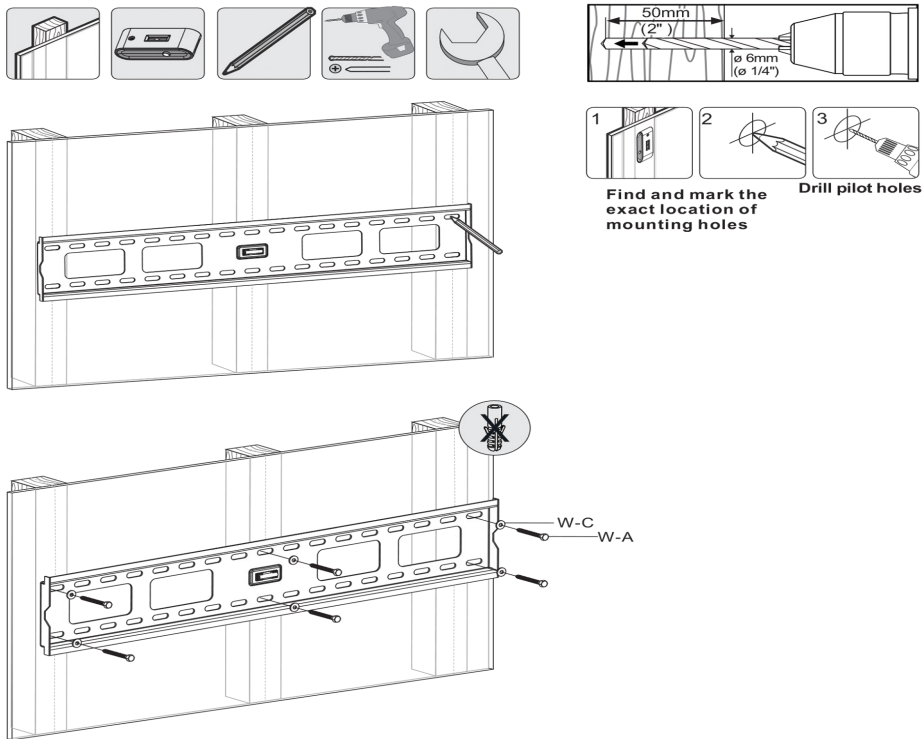

3.1 Wall Plate Mounting—Solid Brick and Concrete

- Verify that the supporting surface will safely support the combined weight of the equipment, hardware, and components.

1. Find and mark the exact location of mounting holes. Make sure wall plate is level prior to drilling holes using supplied level (C).
2. Use a 3/8" drill bit and drill into the brick or concrete 2.2" as shown in fig 3b.
3. Mount wall plate onto the wall using the supplied bolts, anchors, and washers (W-A, W-B and W-C).

Fig 3b

