

J.L. WINGERT CO.

Specification Sheet

**MODELS: SC-2-A-316 / SC-2-A-316/MB / SC-2-A-600
SC-2-A-600/MB / SC-2-A-COP / SC-2-A-COP/MB**

SS040002.A 09/12

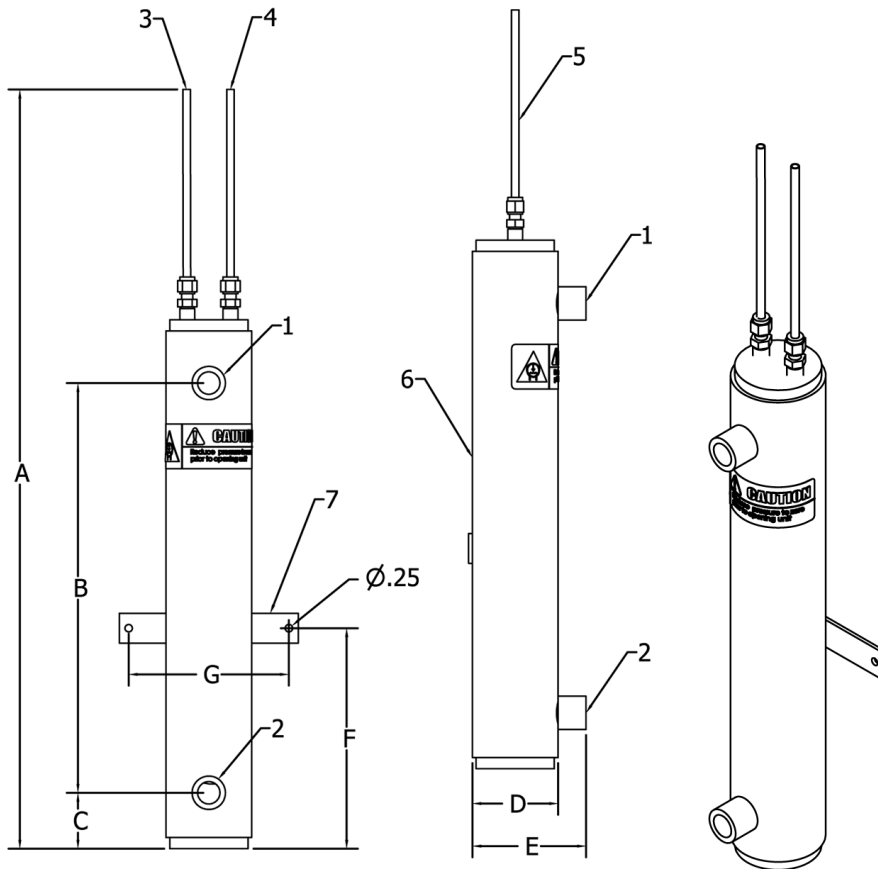

SPECIFICATIONS:

KEY	DESCRIPTION
1	COOLING WATER INLET: 1/2" FNPT
2	COOLING WATER OUTLET: 1/2" FNPT
3	SAMPLE FLUID INLET: 1/4" OD TUBE
4	SAMPLE FLUID OUTLET: 1/4" OD TUBE
5	COIL: 1/4" OD X 20 FT Coil
6	BODY: Sch 40 Carbon Steel Pipe and A36 Carbon Steel End Plug
7	MOUNTING BRACKET: Optional Carbon Steel Mounting Bracket (MB)

OPERATING PARAMETERS	SAMPLE LIQUID	COOLING LIQUID	SAMPLE LIQUID	COOLING LIQUID	SAMPLE LIQUID	COOLING LIQUID
COIL MATERIAL	316 STAINLESS STEEL		ALLOY 600		COPPER	
MAXIMUM TEMPERATURE	600° F (315.5° C)	250° F (121.1° C)	600° F (315.5° C)	250° F (121.1° C)	400° F (204.4° C)	250° F (121.1° C)
MAXIMUM PRESSURE	1500 PSI (103.4 BAR)	200 PSI (13.7 BAR)	1500 PSI (103.4 BAR)	200 PSI (13.7 BAR)	300 PSI (20.6 BAR)	200 PSI (13.7 BAR)

KEY	SC-2-A-316	SC-2-A-316/MB	SC-2-A-600	SC-2-A-600/MB	SC-2-A-COP	SC-2-A-COP/MB
A	25 1/2"	25 1/2"	25 1/2"	25 1/2"	25 1/2"	25 1/2"
B	13 3/4"	13 3/4"	13 3/4"	13 3/4"	13 3/4"	13 3/4"
C	1 7/8"	1 7/8"	1 7/8"	1 7/8"	1 7/8"	1 7/8"
D	2 7/8"	2 7/8"	2 7/8"	2 7/8"	2 7/8"	2 7/8"
E	3 13/16"	3 13/16"	3 13/16"	3 13/16"	3 13/16"	3 13/16"
F	N/A	7 3/8"	N/A	7 3/8"	N/A	7 3/8"
G	N/A	5 3/8"	N/A	5 3/8"	N/A	5 3/8"

Note: All dimensions are +/- 1/8". All weights are approximate. All dimensions are subject to change without notice.

MANUFACTURING: Mixers, Bypass Feeders, Filter Feeders, Bromine Feeders, Sample Coolers, Sludge Traps, Separators, Separator Systems, Tank Stands, Tank Package Systems, Glycol Feed Systems, Coupon Racks, Control Stations, NEMA Enclosures, Custom Packaged Systems and Specialty Welding

P.O. Box 6207 | Garden Grove, CA 92846-6207 / 11800 Monarch St. | Garden Grove, CA 92841-2113 | Phone (714) 379-5519 | Fax (714) 379-5549
Northern California Region | Phone (510) 487-5310 | Southwest Region | Phone (602) 470-1015 | Email: customerservice@jllwingert.com

www.jllwingert.com