



QUFRESH

Fresh Air is Better Air

100 Washington Rd Mineral Wells, TX 76067

SL100-3H

Bathroom Ventilator Specifications

BLOWER:

- High Efficiency ECM Motor designed for Constant Airflow up to 0.4" Static Pressure
- 3 Speed motor allows 100, 80 or 50 CFM setpoint
- Dynamically balanced centrifugal blower wheel for quiet, efficient performance
- Built In Humidity Sensor turns on fan "On Demand"

HOUSING:

- Low Profile 10-1/4" x 10-1/4" x 3-3/8" Housing
- 3-3/8" height allows for 2" x 4" (nominal) joist installations
- Wall or ceiling mounted
- 4" oval duct connector accepts 4" round duct
- Rugged, galvanized steel construction
- Includes mounting tabs and hanger bars to install against joists or studs
- 1/2" electrical connection (Knock out)

GRILLE:

- Polymeric construction
- Fast, Easy, spring installation

Accessories:

- Ceiling Radiation Damper SLCRD

Available as Contractor Packs:

- Housing rough-in SL4HA
- Trim Kit SL-3HB

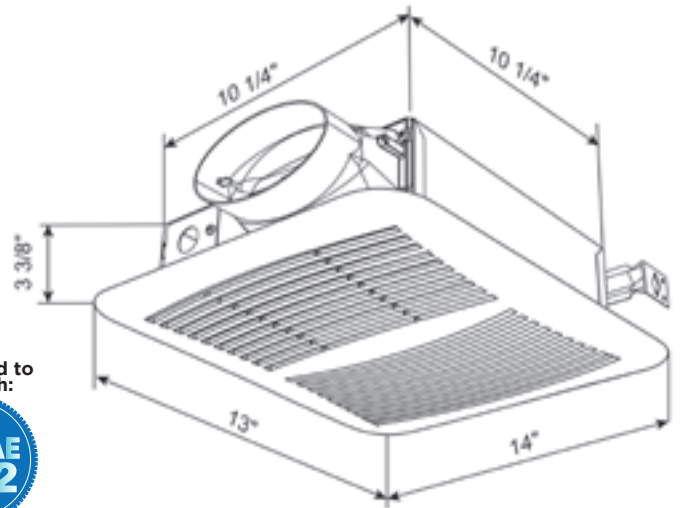

ETL Listed for use over bathtubs and showers when connected to a GFCI protected branch circuit (ceiling mount only).

EXPANDED PERFORMANCE

	Static Pressure (Inches of w.g.)							Fan Speed RPM	Max Watts	Max Amps
	0.00	0.10	0.20	0.25	0.35	0.40	0.45			
Air Flow CFM	102	100	97	97	97	96	87	875	21.0	0.3
Sones		1.2		1.5						
Air Flow CFM	82	80	78	78	77	77	62	800		
Sones		1.0		2.0				725		
Air Flow CFM	50	50	50	50	47	46	46			
Sones		0.6		1.5						

Project		Architect			Contractor		
Location		Engineer			Submitted By		Date
REFERENCE				QTY	REMARKS		