



QUFRESH

Fresh Air is Better Air

Owner's Manual

QuFresh Air Purifier QFAP-950



**99.97%
Effective**
0.3+ micron particles



**3 Speed
Operation**



**Quiet
Operation**



**2 Prong
Plug**



Intertek

FOR HOUSEHOLD USE ONLY

SAFETY



This safety alert symbol is used to alert you to potential personal injury hazards. Obey all safety messages that follow this symbol to avoid possible injury or death.



DANGER

Danger indicates an imminently hazardous situation, which, if not avoided, will result in death or serious injury.



WARNING

Warning indicates a potentially hazardous situation, which, if not avoided, could result in death or serious injury.

SAFETY INSTRUCTIONS WARNING: TO REDUCE THE RISK OF FIRE, ELECTRIC SHOCK, OR INJURY TO PERSONS, OBSERVE THE FOLLOWING:

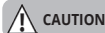

CAUTION

Caution indicates a potentially hazardous situation, which, if not avoided, may result in minor or moderate injury.



ELECTRICAL SHOCK

Used to indicate an electrical shock or electrocution hazard.



Table of Contents

1.	Safety Precautions.....	1
2.	Product Introduction.....	2
3.	Before use.....	3
	a. Removal and Installation of Side Cover Plate.....	3
	b. Place of Air Purifier.....	4
	c. Install the Filter Assembly.....	5
4.	Filter Purification.....	6
5.	Operation Mode and Function Description.....	7
	a. Function Description of Control Panel.....	7
	b. Turn on the Air Purifier.....	7
	c. Air Volume Setting.....	8
	d. Sleep Mode.....	8
	e. Timer Mode.....	8
	f. Child Lock Function.....	8
6.	Maintenance and Cleaning.....	9
	a. Clean Air Purifier.....	9
	b. Replace the Filter Screen.....	10
7.	Troubleshooting.....	11

User Manual

1 Safety Precautions

In order to avoid possible injury or financial loss to you or others, please pay attention to the following safety precautions.

If the power cord is damaged, in order to avoid danger, it must be repaired by the professional personnel of the manufacturer, its maintenance department or similar departments.



Warning



ELECTRICAL SHOCK

Do not touch the power plug with wet hands.

Electric shock may be caused.



WARNING

Before cleaning the air purifier, make sure that the power supply has been disconnected.



CAUTION

Please plug the plug into the power socket before starting the air purifier.

If the plug is not fully inserted into the socket, it may cause electric shock and overheating, and possibly fire.

- Do not use damaged plugs or loose power outlets.



WARNING

Do not damage the power cord and socket.

When using the machine, do not bind the wires. Using the damaged wires may lead to electric shock, short circuit or fire.



CAUTION

Do not disassemble or refit the air purifier.

Disassembly or modification of electrical appliances may lead to electric shock, failure or fire.



ELECTRICAL SHOCK

Do not place rods or other metal objects at the air outlet or opening.

Otherwise, it may touch the internal parts and cause electric shock or damage.

User Manual

2 Product Introduction

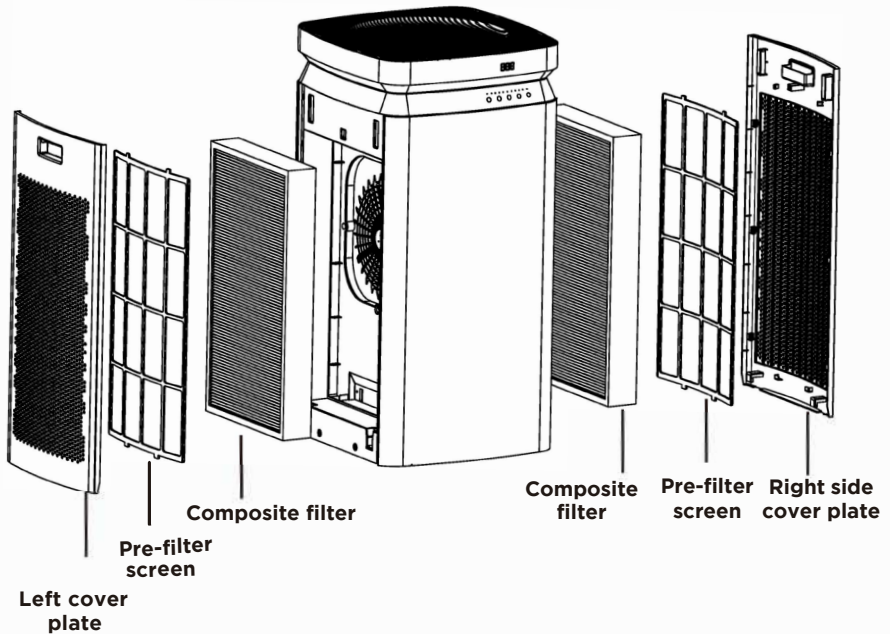
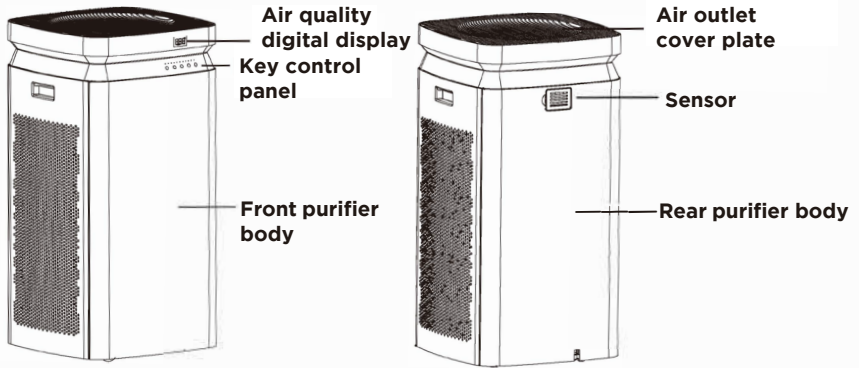

User Manual

3 Before Use

Removal and installation of side cover plate

1. Hold the grooves of the left and right side panel covers by hand and pull them out at the same time.

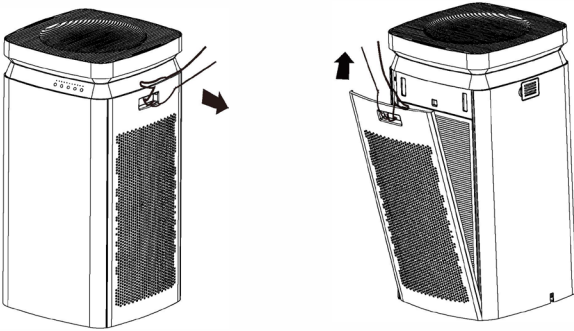

2. When re installing the side panel cover, align and insert the fixed groove, push the side panel cover close to the machine, and the side panel cover will automatically close to the machine.

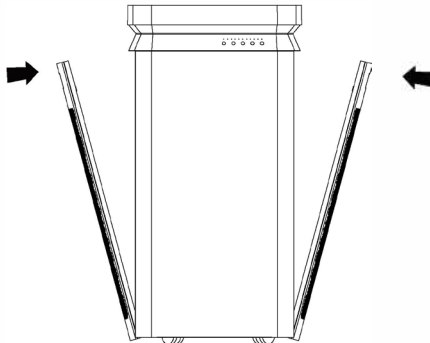

User Manual

Place of air purifier

Do not obstruct the air inlet and outlet to ensure adequate ventilation and maximum efficiency of the machine. In order to achieve good air circulation effect in your room, make sure that the air inlet and outlet of the machine are not less than 20 in. away from the obstacles.

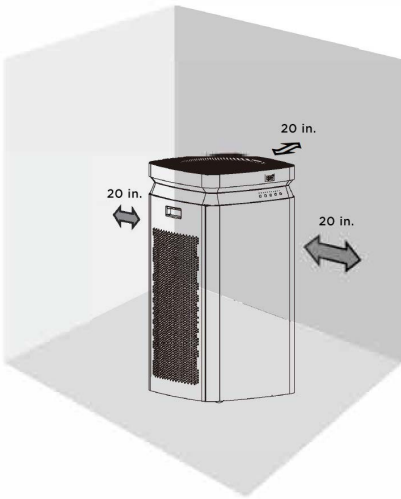

User Manual

Install the filter assembly

All filters are attached to the air purifier, but the packing of the filter must be removed before using the product. Please follow the instructions below to remove the filter and its package, and then put it back into the purifier.

1. Remove all packaging materials and place the machine on a dry, stable, level surface.

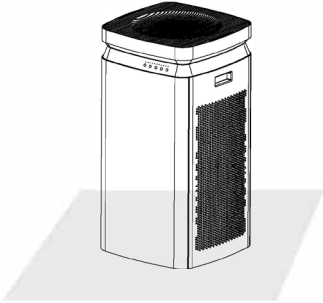

2. Hold the groove of the left and right side plate cover with your hand and pull it out at the same time.

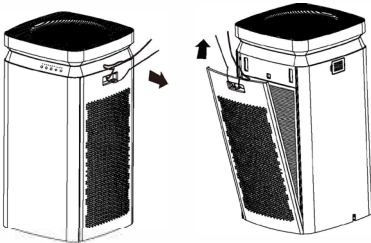

3. Remove all filters inside the purifier.

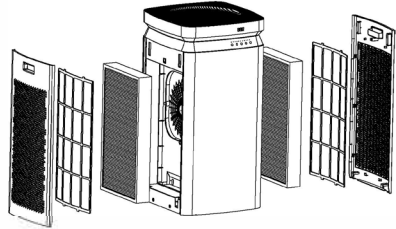

4. Remove all packing materials on the filter screen and put the filter screen back into the purifier.

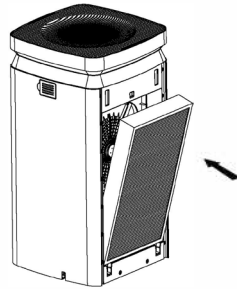

5. Re install the side cover, align and insert the fixed groove, and then push the side cover close to the machine, and the side cover will pull in automatically.

User Manual

4 Filter purification

Step 1: Primary filtration

Step 2: H11 high efficiency filtration

Step 3: Activated carbon filtration

1. Primary filtration

Remove large particles, including hair, fiber, dander, etc.

2. H11 high efficiency filtration

It can effectively filter PM2.5, smoke, pollen, mites and other particles.

3. Activated carbon filtration

High quality activated carbon, modified by special proprietary technology, can effectively purify formaldehyde and other gas pollutants.

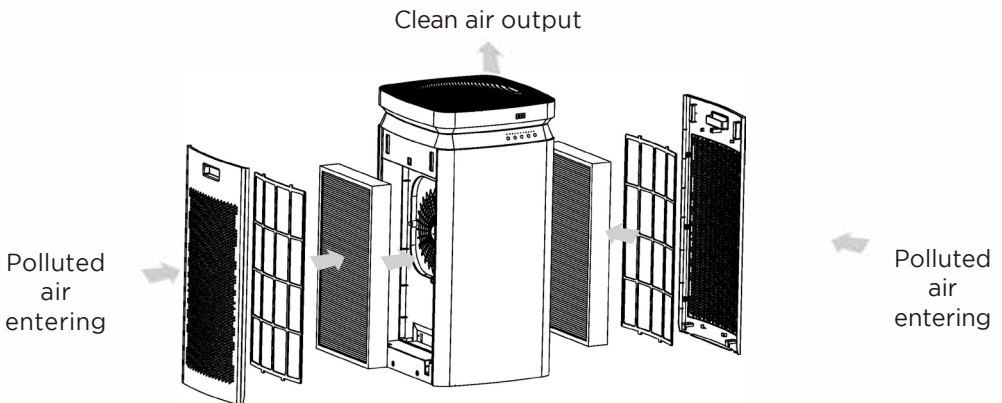

User Manual

5 Usage method

Function description of control panel

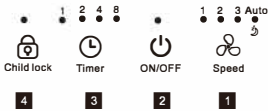

1. Speed button
2. Power button
3. Timer button
4. Child lock button

Plug in the power supply

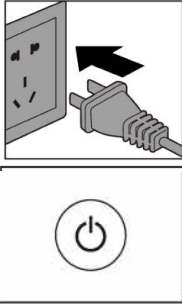

When the power is plugged in, a long beep will sound and all the lights will be on (except the air quality indicator) for 1 second. After that, the air quality indicator will be red for 0.5 second, green for 0.5 second, and blue for 0.5 second. Then the power indicator will be half on, and the machine will enter the standby mode.

Turn on the purifier

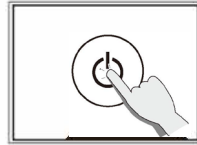

Press the on key (as shown in the figure), the air cleaner will be turned on. Within 10 seconds after the air quality sensor is just opened, the air quality sensor needs to warm up. After 10 seconds of operation, the air quality sensor will automatically and quickly identify the current air quality, and the current air quality can be reflected through the color and digital display of different air quality indicator lights.

Blue	000-075	Excellent
Green	076-150	Good
Red	151-999	Poor

User Manual

Air volume setting

1 2 3 Auto
○ ○ ○ ○



Speed

Fan speed, air volume can be 1, 2, 3, or auto speed, (sleep) cycle selection.

Timer setting

1 2 4 8
○ ○ ○ ○



Timer, the machine can be selected in 2 hours, 4 hours, 6 hours, 8 hours.

Lock Function



Long press the child lock key for 3 seconds to prompt that the sound is on, and the machine enters the child lock mode. In the child lock mode, any key function is invalid. Long press the anion key again for 3 seconds to exit the child lock mode.

User Manual

6 Maintenance and cleaning

Be sure to unplug before cleaning the product. Do not immerse the product in water or any other liquid. The composite filter screen shall not be washed.

Clean air purifier

Clean the inside and outside of the purifier body regularly to prevent dust accumulation.

1. Use a soft dry cloth to wipe the dust off the purifier.
2. Clean the air inlet and outlet with a soft dry cloth.

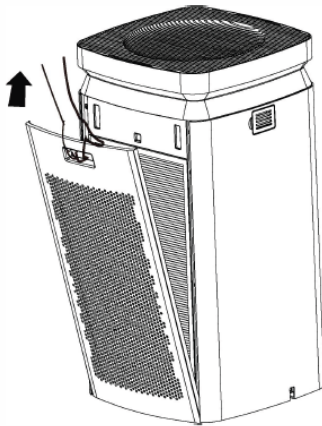

User Manual

Replacing the filter

When the indicator light on the filter reset key flashes slowly, the user is reminded to replace the filter.

1. Remove all filters from the machine and remove all packaging materials from the new filter.

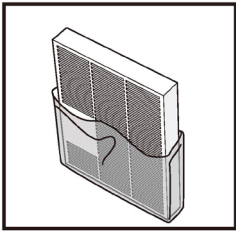

2. Install the composite filter into the machine.

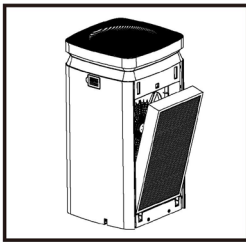

3. Replace the filter screen, re-install the left and right side panels, and plug in the power plug.



Attention

Please shut down unit before replacing the filter.
The filter screen of this product is a composite filter screen, which is easy to damage. The general service cycle is 6 months.
The above time is for reference only, users can change it according to the actual use environment.

User Manual

7 Troubleshooting

This chapter lists the common problems that may be encountered when using this product. If you are unable to solve the problem according to the information below, please contact the customer service center or the dealer.

State	Possible causes	Possible solutions
The machine won't start	The power cord is not plugged in	Pull out the power cord and plug in again
	The power cord is damaged	Contact customer service center or dealer
Fan not working	The machine is not on	Pull out the power plug and plug in the power again
	The motor is damaged	Contact customer service center or dealer
	Foreign particles inside the machine	Contact customer service center or dealer
Poor performance or sub-optimal purification	The filter was not replaced	Replace a new set of filter
	The air inlet or outlet of the machine is blocked	Contact customer service center or dealer
	The plastic package of the filter is not removed	Remove the plastic package of the filter screen for reuse
	There is not proper clearance or space around the machine to ventilate it	Make sure that the air inlet and outlet of the machine are not less than 50cm away from the obstacles
	There is no filter in the machine	Make sure that the filters are placed in the machine in the order indicated
	More than expected room coverage	Recheck whether the area of the used room is consistent with the specified area of the machine

VENTAMATIC, Ltd.
LIMITED WARRANTY STATEMENT

This warranty is underwritten by Falco Insurance Company and is extended to the original retail purchaser of this model or, if this unit is purchased and requires installation by a building contractor, to the original owner of the home. No subsequent purchaser of the unit or of a home in which it is installed is entitled to any of the benefits of this warranty.

This product is warranted against defects in materials and workmanship for a period of one (1) year from the date of original retail purchase. No other parts or components are warranted. There is no warranty for defects caused by abuse, faulty installation, or the like.

Repairs or replacement parts supplied under this warranty are warranted only for the period of this warranty; that is, one (1) year from the date of the original retail purchase of the unit.

In the event of a defect or malfunction, we will replace or repair the defective part or component only and return the new or repaired part to you freight prepaid.

You must bear all other expenses incurred in obtaining repairs, including labor required for field repair or replacement, and the cost of shipping the defective part to us. You must also bear the cost of repair to or replacement of any part or component and the shipping charges incurred for the repair or replacement and return to you of any part or component not covered by this warranty, including parts or components damaged by you.

The company reserves the right to demand and receive written evidence of the date of purchase before undertaking its obligations under this warranty. The right to demand and receive written evidence of date of purchase extends to all licensed dealers of Ventamatic, Ltd. products.

You should, therefore, retain your sales slip and attach a copy of it to the warranty claim.

To start a warranty claim you must:

Contact Ventamatic, Ltd.

An RGA (Returned Goods Authorization) form is required for returns to the factory to ensure your return can be processed efficiently and quickly. Please contact Ventamatic, Ltd. toll-free at 800-433-1626 or via web at www.bvc.com to obtain an RGA and follow the instructions given.

There is no informal dispute settling mechanism available in the event of a controversy involving this warranty.

Any and all implied warranties which may exist terminate upon the expiration of this warranty one (1) year from the date of the original retail purchase. Some states do not allow limitations on how long an implied warranty lasts, so this limitation may not apply to you.

Ventamatic, Ltd. is not liable to you for incidental or consequential damages arising out of defect or malfunction of a unit or its installation or out of any alleged breach of this warranty. Some states do not allow the exclusion or limitation of incidental or consequential damages, so this limitation may not apply to you.

This warranty gives you specific legal rights and you may also have other rights which may vary from state to state.

rev. 04/19