



# QUFRESH

Fresh Air is Better Air

## Owner's Manual

**QuFresh Air Purifier**  
QFAP-210



**99.97%  
Effective**  
0.3+ micron particles



**3 Speed  
Operation**



**Quiet  
Operation**



**2 Prong  
Plug**



**Intertek**

**FOR HOUSEHOLD USE ONLY**

### SAFETY



This safety alert symbol is used to alert you to potential personal injury hazards. Obey all safety messages that follow this symbol to avoid possible injury or death.



**DANGER**

Danger indicates an imminently hazardous situation, which, if not avoided, will result in death or serious injury.



**WARNING**

Warning indicates a potentially hazardous situation, which, if not avoided, could result in death or serious injury.

**SAFETY INSTRUCTIONS WARNING: TO REDUCE THE RISK OF FIRE, ELECTRIC SHOCK, OR INJURY TO PERSONS, OBSERVE THE FOLLOWING:**



**CAUTION**

Caution indicates a potentially hazardous situation, which, if not avoided, may result in minor or moderate injury.



**ELECTRICAL SHOCK**

Used to indicate an electrical shock or electrocution hazard.

# Table of Contents

|    |  |       |
|----|--|-------|
| 1. | Safety Precautions.....                              | 1-2   |
| 2. | Product Introduction.....                            | 3     |
|    | a. Function Description of Control Panel .....       | 4     |
| 3. | Before use.....                                      | 5     |
|    | a. Removal and Installation of Rear Cover Plate..... | 5     |
|    | b. Place of Air Purifier.....                        | 5     |
|    | c. Install the Filter Assembly.....                  | 6     |
|    | d. Understand the Role of Filters.....               | 8     |
|    | e. Integrating Multiple Functions into One.....      | 9     |
|    | f. Unique Triple Purification Technology.....        | 9     |
| 4. | Usage Method.....                                    | 10    |
|    | a. Function Description of Control Panel.....        | 10    |
|    | b. Turn on the Air Purifier.....                     | 11    |
|    | c. Manual Mode.....                                  | 11    |
|    | d. Air Volume Setting.....                           | 12    |
|    | e. Sleep Function.....                               | 12    |
|    | f. Child Lock Function.....                          | 12    |
|    | g. Timer Function.....                               | 12    |
|    | h. Reset Function.....                               | 12    |
| 5. | Maintenance and Cleaning.....                        | 13    |
|    | a. Clean Air Purifier.....                           | 13    |
|    | b. Replace the Filter Screen.....                    | 14    |
|    | c. Operation Steps.....                              | 14-15 |
|    | d. When Idle for a Long Time.....                    | 16    |
|    | e. Reference Time for Replacing Filter Screen.....   | 16    |
| 6. | Troubleshooting.....                                 | 17    |
| 7. | Other Information.....                               | 18    |
|    | a. Warranty and Service.....                         | 18    |
|    | b. Ordering Parts or Accessories.....                | 18    |
|    | c. Recycling.....                                    | 18    |

# User Manual

## 1 Safety Precautions

In order to avoid possible injury or financial loss to you or others, please pay attention to the following safety precautions.

If the power cord is damaged, in order to avoid danger, it must be repaired by the professional personnel of the manufacturer, its maintenance department or similar departments.



### Warning



ELECTRICAL SHOCK

**Do not touch the power plug with wet hands.**

Electric shock may be caused.



WARNING

**Before cleaning the air purifier, make sure that the power supply has been disconnected.**



CAUTION

**Please plug the plug into the power socket before starting the air purifier.**

If the plug is not fully inserted into the socket, it may cause electric shock and overheating, and possibly fire.

- Do not use damaged plugs or loose power outlets.



WARNING

**Do not damage the power cord and socket.**

When using the machine, do not bind the wires. Using the damaged wires may lead to electric shock, short circuit or fire.



CAUTION

**Do not disassemble or refit the air purifier.**

Disassembly or modification of electrical appliances may lead to electric shock, failure or fire.



ELECTRICAL SHOCK

**Do not place rods or other metal objects at the air outlet or opening.**

Otherwise, it may touch the internal parts and cause electric shock or damage.

# User Manual

## Warning

- If you need to move the product, please disconnect the power of the product first.
- Be sure to move the product slowly.
- Do not move the product by pulling the power cord.
- Do not move the machine while the product is in operation. If you need to move the machine, please turn off the power.

## Warning

**In case of any of the following conditions, please turn off the power of the machine immediately.**

- If a switch does not work.
- If the circuit breaker works or the fuse burns out.
- If the power cord or plug is abnormally hot.
- If you find a burnt odor or abnormal sound or vibration.
- If there is any other abnormal phenomenon or fault.

## Warning

### CAUTION

**Do not use solvents to clean the air purifier.**

### ELECTRICAL SHOCK

**Do not pull power cord by the wire.**

If the wire is pulled, it may cause short circuit, or damage the wire, leading to fire or electric shock.

### WARNING

**Not recommended for use in kitchen.**

### ELECTRICAL SHOCK

**The air purifier may cause electric shock or fire if it gets wet.**

- The air purifier should not be used as ventilation or air extraction equipment.

# User Manual

## 2 Product Introduction

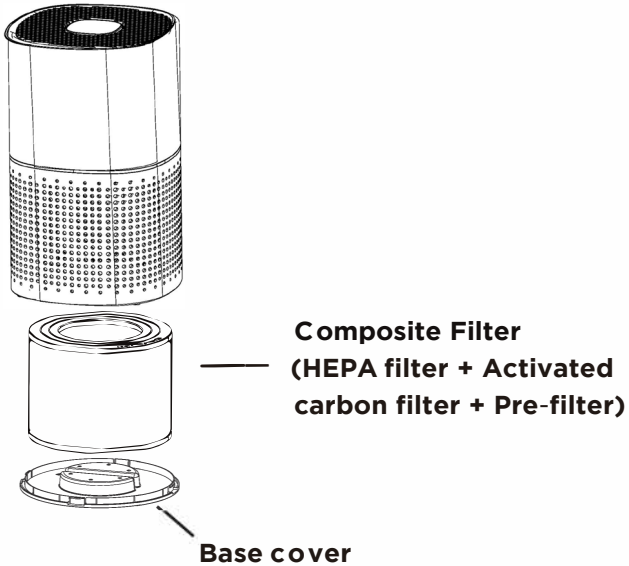
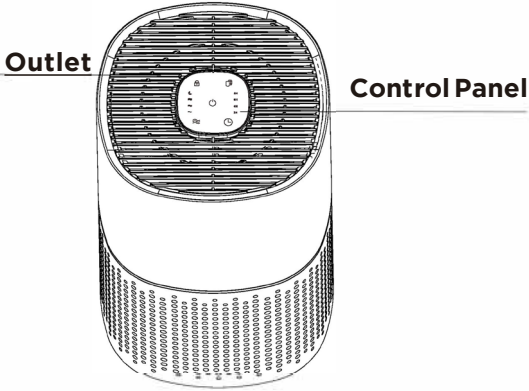

If there is any difference between the product picture and the real object, the real object shall prevail.

# User Manual

## Function description of control panel

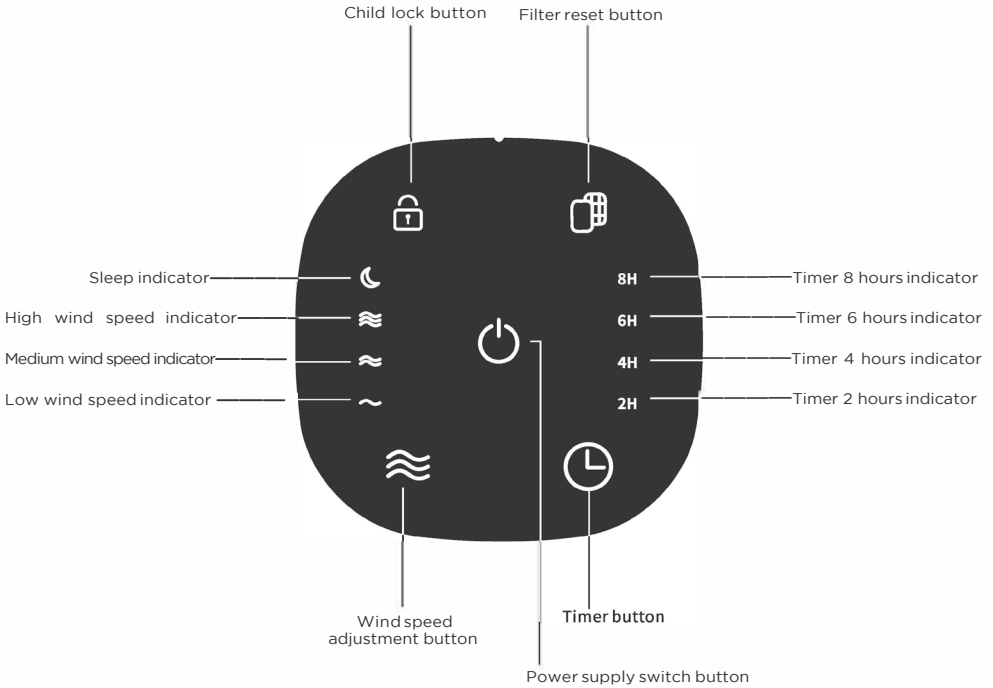

# User Manual

## Removal and installation method of rear cover plate

### 1 Disassembly method of base

Press the indicator key to screw out the base

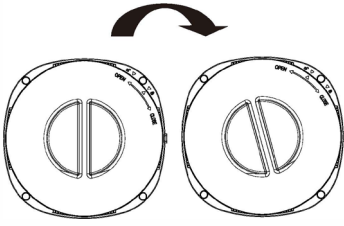

1

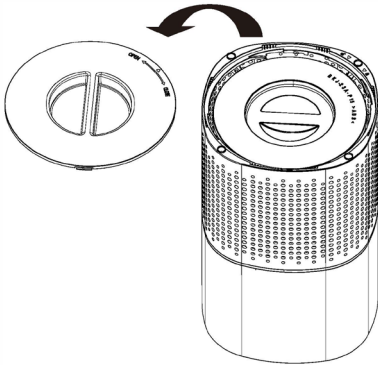

2

### 2 Installation method of base

Re-install the base, press the unlock key to align, and screw it in the locking direction.

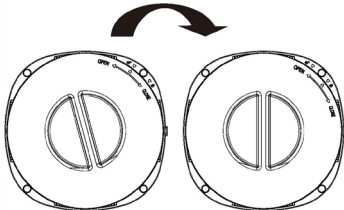

## Place of air purifier

**In order to achieve good air circulation effect in your room, make sure that the air inlet and outlet of the machine are not less than 8 in. away from the obstacles.**

Please use at least 3 ft. away from TV, radio and other electrical appliances.

Please do not plug the power plug into the same socket as the power plug of TV, radio and other electrical appliances.

- If you use it in the same place for a long time, it will contaminate the wall around the host.
- Do not obstruct the air inlet and outlet to ensure adequate ventilation and maximum efficiency of the machine.

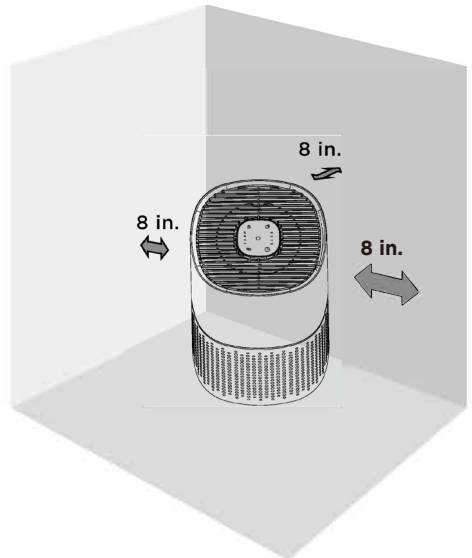

# User Manual

## Install the filter

### Information

This air purifier is equipped with a filter screen inside, but before using the product, be sure to remove the packaging of the filter screen. Please follow the instructions below to remove the filter and its package, and then put it back into the purifier.

### Warning

- Ensure that the power plug is installed, repaired and transported when the power supply is disconnected.
- Do not operate the machine without filter.
- Remove the plastic packaging of the filter screen before use.

2. Press the bottom cover with your fingers, screw it out according to the unlocking direction, and take out the base upward at the same time.

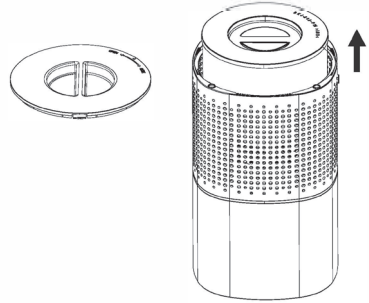

3. Remove the filter screen inside the purifier.

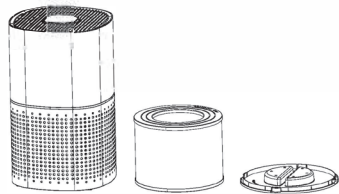

## Operation Steps

When using the air purifier for the first time, please follow the steps below to install the filter correctly.

1. Remove all packaging materials and place the machine on a dry, stable, level surface

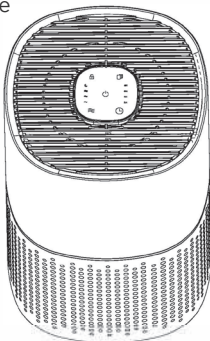

4. Remove the packing material from the filter screen.

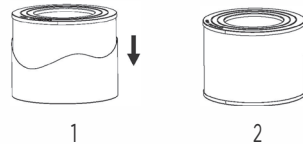



# User Manual

5. Put the filter back into the purifier.

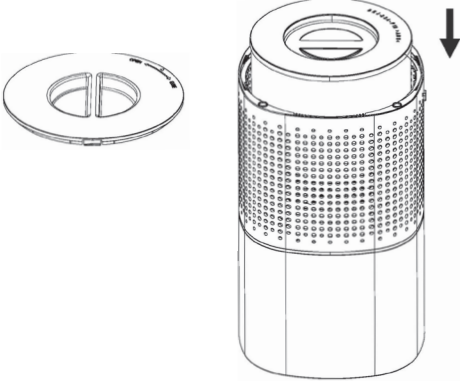

6. Press the indicator key to put in the bottom cover and tighten it.

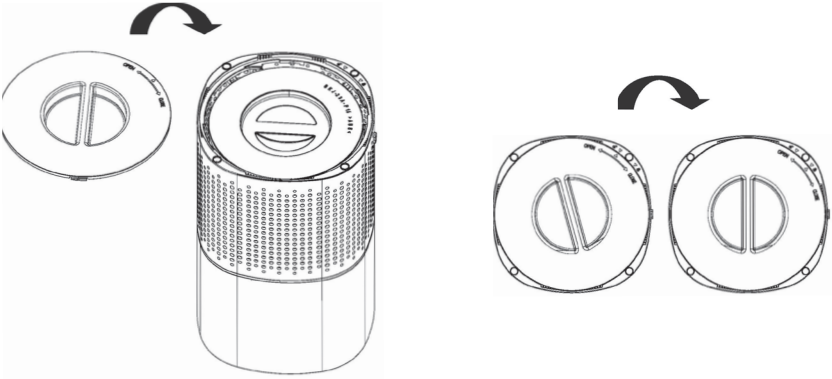

## Tips

When installing the bottom cover, please install it carefully to prevent hand clamping.

# User Manual

## Understand the role of filters

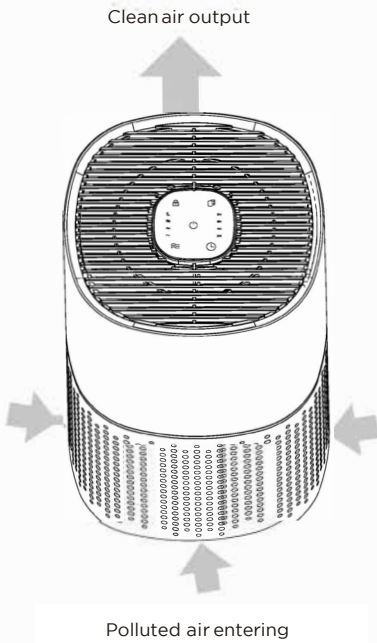

1

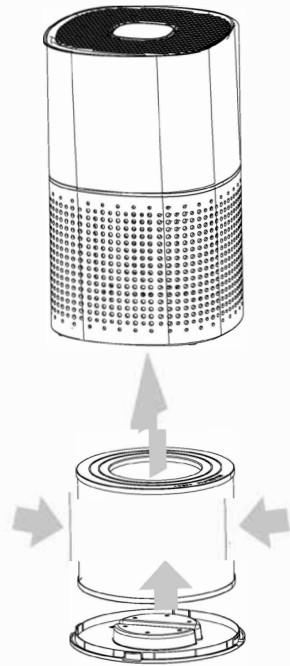

2

The picture is for reference only. If there is any difference between the real object and the picture, the real object shall prevail.

## Integrating multiple functions into one

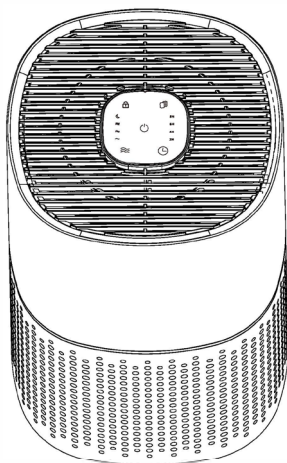

- 4 speed switch
- Timer setting
- Prompt to replace the filter screen
- It is equipped with manual, sleep and child lock operation modes

## Unique triple purification technology



|  |  |
|--|--|
| The primary filter screen              | Intercepts hair, fiber, large particles, dander, etc.  |
| HEPA                                   | Efficient removal of particulate matter such as filter, smoke and pollen.  |
| High quality modified activated carbon | High quality activated carbon, modified by special proprietary technology, can effectively purify formaldehyde and other gas pollutants. |

Note: High efficiency HEPA and high efficiency activated carbon are combined in the same filter screen.

# User Manual

## 4 Usage method

### Function description of control panel

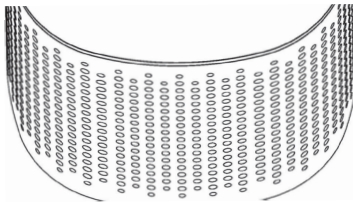
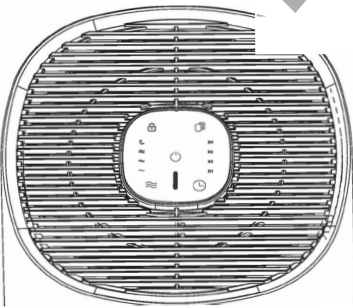
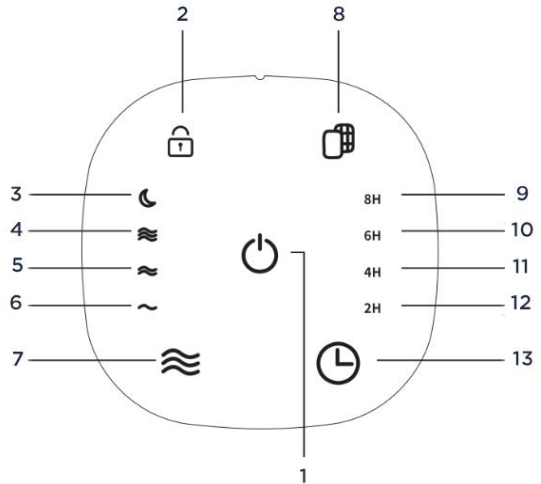

1. Power Supply Switch Button
2. Child Lock Button
3. Sleep Indicator
4. High Wind Speed Indicator
5. Medium Wind Speed Indicator
6. Low Wind Speed Indicator
7. Wind Speed Adjustment Button
8. Filter Reset Button
9. Timer 8 Hours Indicator
10. Timer 6 Hours Indicator
11. Timer 4 Hours Indicator
12. Timer 2 Hours Indicator
13. Timer Button

# User Manual

## Turn on the purifier



Press the power button, the machine will sound a long beep. The machine will enter the automatic operation mode, the automatic gear light will be on, and the fan will work in gear2 (preheating for 10 seconds, and the indicator light of the air quality in time and space will be displayed orange). After the sensor is preheated, the color is displayed according to the current detected value. The machine is operated in automatic mode by default. When the machine is running in automatic mode, the running wind speed will be selected automatically according to the air quality status.





## Manual Mode



After power on, the air purifier is in standby mode. Press the on/ off button to start the air purifier. To enter the automatic mode, press the fan speed adjustment button to prompt the sound to start. The fan speed is in the low, medium, high fan and sleep. After adjusting the fan speed, the product runs according to the chosen speed.

# User Manual

## Air Volume Setting

-  Sleep
-  Highgrade
-  Medium grade
-  Low grade



Air volume regulation, air volume can be weak, medium and strong automatic cycle selection.

## Timer Setting

- 8h
- 6h
- 4h
- 2h



Timer: The machine can be selected in 2 hours, 4 hours, 6 hours, 8 hours according to the needs of users.

## Sleep function



When the product is running, press the "wind speed" key until the sleep indicator is on. When the sound is on, enter the sleep mode, and the sleep indicator will be on (the sleep indicator will be off after 10 seconds). When in the sleep mode, the fan sleep gear will run, and other indicators will be off. Press any key to exit the sleep mode.

## Reset function



When the filter screen is replaced, the user can press the "reset" key for 3 seconds after the filter screen is replaced. The filter screen is reset and the filter screen replacement indicator is off.

## Child lock function



Long press the child lock button for 3 seconds, the sound will be prompted, the child lock indicator will be on, and the operation panel will enter the child lock state. Press any key (except long press the child lock key), the child lock indicator will flash for 3 times, and other button functions will be invalid, indicating the child lock status of the current operation panel. Long press the child lock button for 3 seconds to prompt the sound to start, exit the child lock state, and all button functions return to normal.

# User Manual

## 5 Maintenance and cleaning methods

---

Be sure to unplug the power plug before cleaning the product.

Do not immerse the product in water or any other liquid.

Do not use abrasives. Use corrosive or flammable cleaning agents (such as bleach or alcohol) to clean any parts of the product.

The composite filter is not washable.



### Clean air purifier

Clean the inside and outside of the purifier body regularly to prevent dust accumulation.

1. Use a soft dry cloth to wipe the dust off the purifier.
2. Clean the air inlet and outlet with a soft dry cloth.

# User Manual

## Replace the filter screen

### Information

When the reset button light flashes, remind the user to replace the filter



Reset

### ⚡ Attention

When the product is working, the indicator light for replacing the filter will flash, and the buzzer will sound "Ding, Ding" alarm to remind the user to replace the filter, but the purifier can still work normally.

### ⚡ Attention

Please shut down and unplug the power plug before replacing the filter. After replacing the filter, if the replacement indicator still flickers after starting the machine, please press the reset key for 3 seconds to reset the filter. The replacement indicator turns off and the filter reset is completed.

### 💬 Tips

Put the plastic filter into the machine before disassembly

## Operation steps

1. The machine reminds that the filter needs to be replaced



Reset

2. Turn off the power, stop the purifier, and then unplug the power plug.

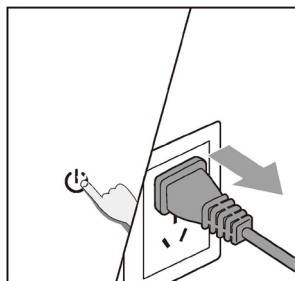

3. Press the bottom cover with your fingers, screw it out according to the unlocking direction, and take out the bottom cover upward at the same time.

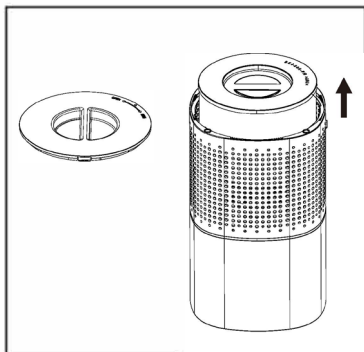



# User Manual

4. Remove the filter inside the purifier and replace it.

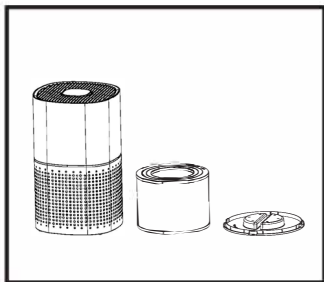

7. Put in the filter screen again, press the indicator key to put in the bootom cover and tighten it.

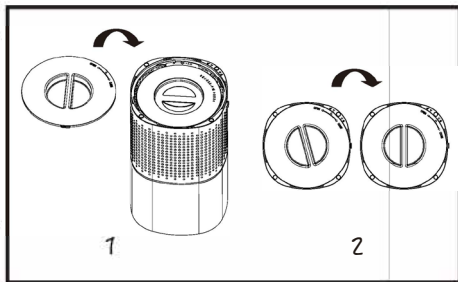

5 Remove the packing material from the new filter screen

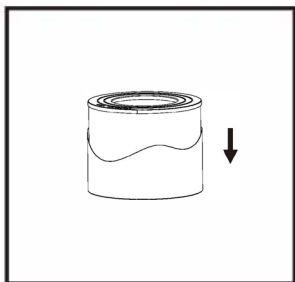

8. After replacing the filter, plug in the power plug and press the reset key for 3 seconds to reset the machine.

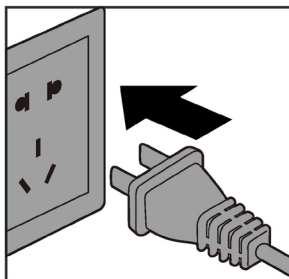

6. Put the filter back into the purifier.

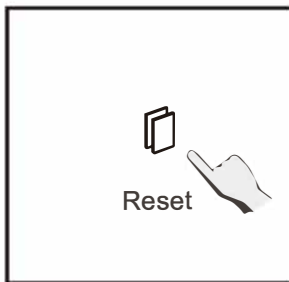
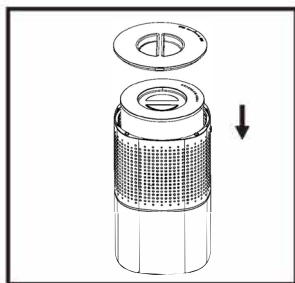

# User Manual

## When idle for a long time

Pull off the power plug. (because standby mode also consumes power.) Dry the interior thoroughly.

Store the machine in a dry and ventilated place. (keeping the product flat or upside down may lead to product failure)

## Reference time for replacing filter screen

The filter screen of this product is primary filter+ HEPA+ activated carbon filter. The filter screen cannot be washed and is damaged. Please do not press it hard. The general service life is six months

The above time is only a reference time, users can change it in advance according to the actual use environment.

### Attention

Please shut down and cut off the power plug before replacing the filter

# User Manual

## 6 Troubleshooting

This chapter lists the common problems that may be encountered when using this product. If you are unable to solve the problem according to the information below, please contact the customer service center or the dealer.

| State   | Possible causes  | Possible solutions  |
|---|--|---|
| The machine can't be started                                      | The power plug is not in place   | Pull out the power plug and plug in the power again   |
|   | The power plug or wire is damaged  | Contact customer service center or dealer   |
| Fan not working   | The machine is not on  | Plug in the power and turn on the machine again   |
|   | The motor is damaged   | Contact customer service center or dealer   |
|   | Motor loose or foreign particles inside the machine                      | Contact customer service center or dealer   |
| Poor purification performance or no optimal purification capacity | The filter was not replaced  | Replace a new set of filter   |
|   | The air inlet or outlet of the machine is blocked                        | Contact customer service center or dealer   |
|   | The plastic package of the filter is not removed                         | Remove the plastic package of the filter screen for reuse   |
|   | There is no proper clearance or space around the machine to ventilate it | Make sure that the air inlet and outlet of the machine are not less than 50cm away from the obstacles |
|   | There is no filter in the machine  | Make sure that the filters are placed in the machine in the order indicated                           |
|   | More than expected room coverage   | Recheck whether the area of the used room is consistent with the specified area of the machine        |

# User Manual

## Warranty and Service

If you need information or have any questions, you can contact our customer service team, toll free at (800) 433-1626.

## Ordering parts or accessories

If you need to replace parts or purchase additional parts, please contact our customer service team, toll free at (800) 433-1626.

## Choose Parts

## 7 Other Information

---

### Recycling

---



When discarding products, please do not stack them with general domestic waste. Please understand the local regulations on classifying mobile phone electronic or electrical products

Proper disposal of the product helps to avoid potential negative effects on the environment and human health

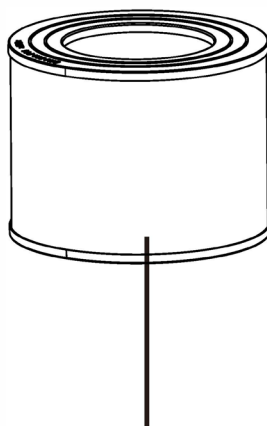

Pre-filter + HEPA+ activated carbon composite filter screen

**VENTAMATIC, Ltd.**  
**LIMITED WARRANTY STATEMENT**

This warranty is underwritten by Falco Insurance Company and is extended to the original retail purchaser of this model or, if this unit is purchased and requires installation by a building contractor, to the original owner of the home. No subsequent purchaser of the unit or of a home in which it is installed is entitled to any of the benefits of this warranty.

This product is warranted against defects in materials and workmanship for a period of one (1) year from the date of original retail purchase. No other parts or components are warranted. There is no warranty for defects caused by abuse, faulty installation, or the like.

Repairs or replacement parts supplied under this warranty are warranted only for the period of this warranty; that is, one (1) year from the date of the original retail purchase of the unit.

In the event of a defect or malfunction, we will replace or repair the defective part or component only and return the new or repaired part to you freight prepaid.

You must bear all other expenses incurred in obtaining repairs, including labor required for field repair or replacement, and the cost of shipping the defective part to us. You must also bear the cost of repair to or replacement of any part or component and the shipping charges incurred for the repair or replacement and return to you of any part or component not covered by this warranty, including parts or components damaged by you.

The company reserves the right to demand and receive written evidence of the date of purchase before undertaking its obligations under this warranty. The right to demand and receive written evidence of date of purchase extends to all licensed dealers of Ventamatic, Ltd. products.

You should, therefore, retain your sales slip and attach a copy of it to the warranty claim.

**To start a warranty claim you must:**

Contact Ventamatic, Ltd.

An RGA (Returned Goods Authorization) form is required for returns to the factory to ensure your return can be processed efficiently and quickly. Please contact Ventamatic, Ltd. toll-free at 800-433-1626 or via web at [www.bvc.com](http://www.bvc.com) to obtain an RGA and follow the instructions given.

There is no informal dispute settling mechanism available in the event of a controversy involving this warranty.

Any and all implied warranties which may exist terminate upon the expiration of this warranty one (1) year from the date of the original retail purchase. Some states do not allow limitations on how long an implied warranty lasts, so this limitation may not apply to you.

Ventamatic, Ltd. is not liable to you for incidental or consequential damages arising out of defect or malfunction of a unit or its installation or out of any alleged breach of this warranty. Some states do not allow the exclusion or limitation of incidental or consequential damages, so this limitation may not apply to you.

This warranty gives you specific legal rights and you may also have other rights which may vary from state to state.

rev. 04/19