



# Super Pump® XE

»»» Ultra-High Efficiency Pumps

**SUPER EFFICIENT PERFORMANCE,  
SUPER AFFORDABLE PRICE**

## EXCEPTIONAL ENERGY EFFICIENCY WITH A LOW PURCHASE PRICE.

Hayward Super Pump sets the industry standard for excellence and value—and new Super Pump XE is no exception. Offering energy efficiency that outperforms Dept. of Energy standards while cutting pump equipment costs by almost a third, Super Pump XE is the just-right pump for just about any pool. With quick and easy installation and dual-voltage capability, it's the most versatile way to unmatched value.

### KEY FEATURES

- » **Industry-leading efficiency** exceeds DOE benchmarks and performance of many competitive VS pumps
- » **Easily programmable** with up to 6 selectable speeds
- » **Dual-voltage capability** (230V/115V) offers more versatility for installation
- » **Simple installation** with up to 2" shorter length than single-speed models and no additional equipment requirements

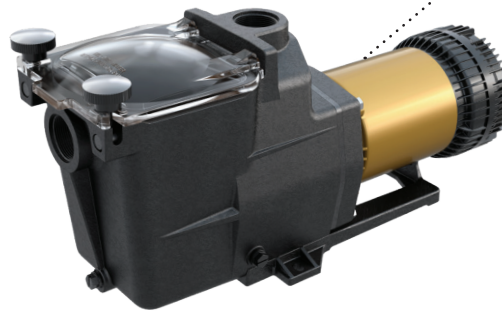

**Easy-access control** toggles between speeds at the touch of a button

**EXPERT LINE®**  
ONLY FROM POOL PROS



Find local utility rebates at [energystar.gov](http://energystar.gov)

### SPECIFICATIONS

MODEL NUMBER	TOTAL HP	VOLTAGE	WARRANTY
SP2610X15XE	1.65	230/115V	3 years*
SP2615X20XE	2.25	230/115V	3 years*

\*When sold by a Totally Hayward® Partner. Exclusions, other terms and conditions may apply—visit [hayward.com/expert](http://hayward.com/expert) for details.

### SUPER PUMP XE DIMENSIONS (INCHES)

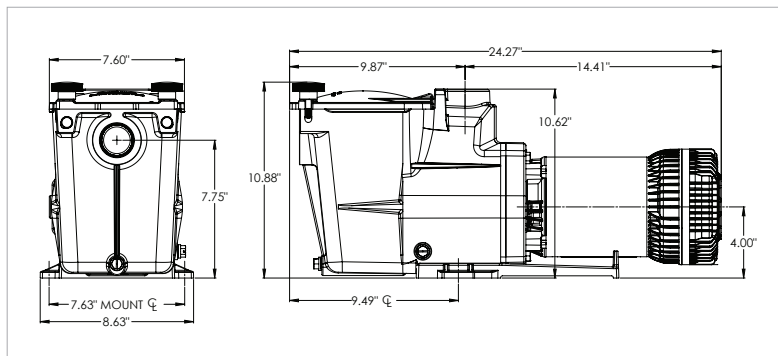

### SUPER PUMP XE PERFORMANCE COMPARISON

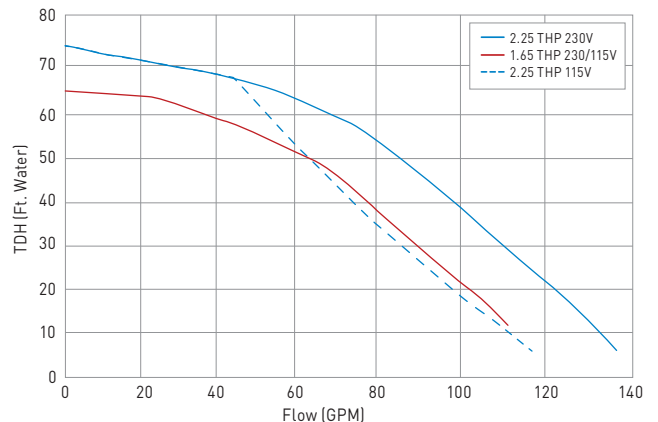

Super Pump XE pumps are listed by:

» [hayward.com](http://hayward.com) » 1-888-HAYWARD | Pumps » Filters » Heating » Cleaners » Sanitization » Automation » Lighting » Water Features » White Goods

Hayward, Hayward & Design, the H logo, Expert Line, Super Pump and Totally Hayward are registered trademarks of Hayward Industries, Inc. ENERGY STAR is a registered mark owned by the U.S. government. All other trademarks not owned by Hayward are the property of their respective owners. Hayward is not in any way affiliated with or endorsed by those third parties. © 2021 Hayward Industries, Inc.

eLITSPXE21