

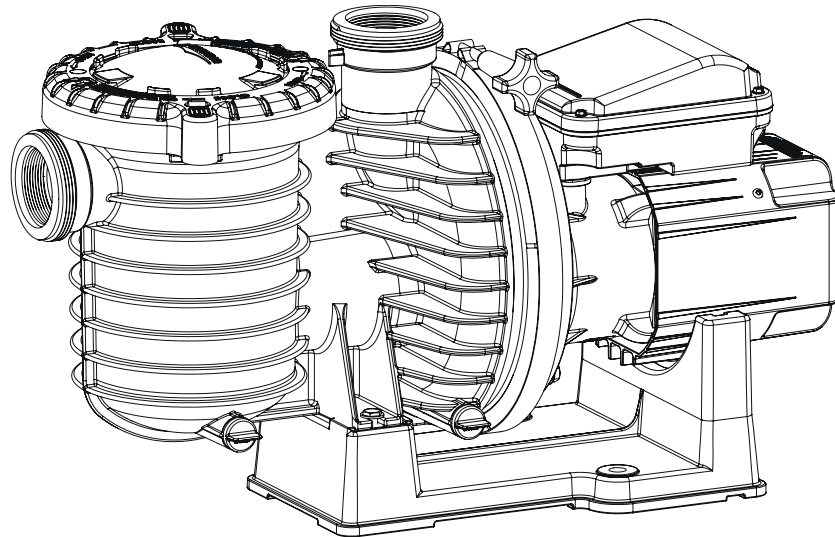

MAX-E-PRO[®]

POOL AND SPA PUMP



INSTALLATION AND USER'S GUIDE

IMPORTANT SAFETY INSTRUCTIONS
READ AND FOLLOW ALL INSTRUCTIONS
SAVE THESE INSTRUCTIONS

IMPORTANT PUMP WARNING AND SAFETY INSTRUCTIONS



IMPORTANT NOTICE

This guide provides installation and operation instructions for this pump. Consult Pentair with any questions regarding this equipment.

Attention Installer: This guide contains important information about the installation, operation and safe use of this product. This information should be given to the owner and/or operator of this equipment after installation or left on or near the pump.

Attention User: This manual contains important information that will help you in operating and maintaining this product. Please retain it for future reference.

READ AND FOLLOW ALL INSTRUCTIONS SAVE THESE INSTRUCTIONS



This is the safety alert symbol. When you see this symbol on your system or in this manual, look for one of the following signal words and be alert to the potential for personal injury.

DANGER

Warns about hazards that can cause death, serious personal injury, or major property damage if ignored.

WARNING

Warns about hazards that may cause death, serious personal injury, or major property damage if ignored.

CAUTION

Warns about hazards that may or can cause minor personal injury or property damage if ignored.

NOTE

Indicates special instructions not related to hazards.

Carefully read and follow all safety instructions in this manual and on equipment. Keep safety labels in good condition; replace if missing or damaged.

When installing and using this electrical equipment, basic safety precautions should always be followed, include the following:

DANGER

FAILURE TO FOLLOW ALL INSTRUCTIONS AND WARNINGS CAN RESULT IN SERIOUS BODILY INJURY OR DEATH. **THIS PUMP SHOULD BE INSTALLED AND SERVICED ONLY BY A QUALIFIED POOL SERVICE PROFESSIONAL. INSTALLERS, POOL OPERATORS AND OWNERS MUST READ THESE WARNINGS AND ALL INSTRUCTIONS IN THE OWNER'S MANUAL BEFORE USING THIS PUMP. THESE WARNINGS AND THE OWNER'S MANUAL MUST BE LEFT WITH THE POOL OWNER.**

WARNING

Do not permit children to use this product.

WARNING

RISK OF ELECTRICAL SHOCK. Connect only to a branch circuit protected by a ground-fault circuit-interrupter (GFCI). Contact a qualified electrician if you cannot verify that the circuit is protected by a GFCI.

WARNING

This unit must be connected only to a supply circuit that is protected by a ground-fault circuit-interrupter (GFCI). Such a GFCI should be provided by the installer and should be tested on a routine basis. To test the GFCI, push the test button. The GFCI should interrupt power. Push the reset button. Power should be restored. If the GFCI fails to operate in this manner, the GFCI is defective. If the GFCI interrupts power to the pump without the test button being pushed, a ground current is flowing, indicating the possibility of an electric shock. Do not use this pump. Disconnect the pump and have the problem corrected by a qualified service representative before using.

CAUTION

This pump is for use with permanent swimming pools and may also be used with hot tubs and spas if so marked. Do not use with storable pools. A permanently-installed pool is constructed in or on the ground or in a building such that it cannot be readily disassembled for storage. A storable pool is constructed so that it is capable of being readily disassembled for storage and reassembled to its original integrity.

General Warnings

- Never open the inside of the drive motor enclosure. There is a capacitor bank that holds a 230 VAC charge even when there is no power to the unit.
- The pump is not submersible.
- The pump is capable of high flow rates; use caution when installing and programming to limit pumps performance potential with old or questionable equipment.
- Code requirements for electrical connection differ from country to country, state to state, as well as local municipalities. Install equipment in accordance with the National Electrical Code and all applicable local codes and ordinances.
- Before servicing the pump; switch OFF power to the pump by disconnecting the main circuit to the pump.
- This appliance is not intended for use by persons (including children) of reduced physical, sensory or mental capabilities, or lack of experience and knowledge, unless they have been given supervision or instruction concerning the use of the appliance by a person responsible for their safety.

DANGER

SUCTION ENTRAPMENT HAZARD: STAY OFF THE MAIN DRAIN AND AWAY FROM ALL SUCTION OUTLETS! THIS PUMP IS NOT EQUIPPED WITH SAFETY VACUUM RELEASE SYSTEM (SVRS) PROTECTION AND DOES NOT PROTECT AGAINST BODY OR LIMB ENTRAPMENTS, DISEMBOWELMENTS (WHEN A PERSON SITS ON A BROKEN OR UNCOVERED POOL DRAIN) OR HAIR ENTANGLEMENTS.



THIS PUMP PRODUCES HIGH LEVELS OF SUCTION AND CREATES A STRONG VACUUM AT THE MAIN DRAIN AT THE BOTTOM OF THE BODY OF WATER. THIS SUCTION IS SO STRONG THAT IT CAN TRAP ADULTS OR CHILDREN UNDER WATER IF THEY COME IN CLOSE PROXIMITY TO A DRAIN OR A LOOSE OR BROKEN DRAIN COVER OR GRATE.

THE USE OF UNAPPROVED COVERS OR ALLOWING USE OF THE POOL OR SPA WHEN COVERS ARE MISSING, CRACKED OR BROKEN CAN RESULT IN BODY OR LIMB ENTRAPMENT, HAIR ENTANGLEMENT, BODY ENTRAPMENT, EVisCERATION AND/OR DEATH.

The suction at a drain or outlet can cause:

Limb Entrapment: When a limb is sucked or inserted into an opening resulting in a mechanical bind or swelling. This hazard is present when a drain cover is missing, broken, loose, cracked or not properly secured.

Hair Entanglement: When the hair tangles or knots in the drain cover, trapping the swimmer underwater. This hazard is present when the flow rating of the cover is too small for the pump or pumps.

Body Entrapment: When a portion of the body is held against the drain cover trapping the swimmer underwater. This hazard is present when the drain cover is missing, broken or the cover flow rating is not high enough for the pump or pumps.

EVisCeration/Disembowelment: When a person sits on an open pool (particularly a child wading pool) or spa outlet and suction is applied directly to the intestines, causing severe intestinal damage. This hazard is present when the drain cover is missing, loose, cracked, or not properly secured.

Mechanical Entrapment: When jewelry, swimsuit, hair decorations, finger, toe or knuckle is caught in an opening of an outlet or drain cover. This hazard is present when the drain cover is missing, broken, loose, cracked, or not properly secured.

NOTE: ALL SUCTION PLUMBING MUST BE INSTALLED IN ACCORDANCE WITH THE LATEST NATIONAL AND LOCAL CODES, STANDARDS AND GUIDELINES.

IMPORTANT PUMP WARNING AND SAFETY INSTRUCTIONS

⚠ WARNING TO MINIMIZE THE RISK OF INJURY DUE TO SUCTION ENTRAPMENT HAZARD:

- A properly installed and secured ANSI/ASME A112.19.8 approved anti-entrapment suction cover must be used for each drain.
- Each suction cover must be installed at least three (3') feet apart, as measured from the nearest point to nearest point.
- Regularly inspect all covers for cracks, damage and advanced weathering.
- If a cover becomes loose, cracked, damaged, broken or is missing, replace with an appropriate certified cover.
- Replace drain covers as necessary. Drain covers deteriorate over time due to exposure to sunlight and weather.
- Avoid getting hair, limbs or body in close proximity to any suction cover, pool drain or outlet.
- Disable suction outlets or reconfigure into return inlets.

⚠ WARNING The pump can produce high levels of suction within the suction side of the plumbing system. These high levels of suction can pose a risk if a person comes within the close proximity of the suction openings. A person can be seriously injured by this high level of vacuum or may become trapped and drown. It is absolutely critical that the suction plumbing be installed in accordance with the latest national and local codes for swimming pools.

⚠ WARNING A clearly labeled emergency shut-off switch for the pump must be in an easily accessible, obvious place. Make sure users know where it is and how to use it in case of emergency.

The Virginia Graeme Baker (VGB) Pool and Spa Safety Act creates new requirements for owners and operators of commercial swimming pools and spas.

Commercial pools or spas constructed on or after December 19, 2008, shall utilize:

(A) A multiple main drain system without isolation capability with suction outlet covers that meet ASME/ANSI A112.19.8a Suction Fittings for Use in Swimming Pools, Wading Pools, Spas, and Hot Tubs and either:

- (i) A safety vacuum release system (SVRS) meeting ASME/ANSI A112.19.17 Manufactured Safety Vacuum Release systems (SVRS) for Residential and Commercial Swimming Pool, Spa, Hot Tub, and Wading Pool Suction Systems and/or ASTM F2387 Standard Specification for Manufactured Safety Vacuum Release Systems (SVRS) for Swimming pools, Spas and Hot Tubs or
- (ii) A properly designed and tested suction-limiting vent system or
- (iii) An automatic pump shut-off system.

Commercial pools and spas constructed prior to December 19, 2008, with a single submerged suction outlet shall use a suction outlet cover that meets ASME/ANSI A112.19.8a and either:

- (A) A SVRS meeting ASME/ANSI A112.19.17 and/or ASTM F2387, or
- (B) A properly designed and tested suction-limiting vent system, or
- (C) An automatic pump shut-off system, or
- (D) Disabled submerged outlets, or
- (E) Suction outlets shall be reconfigured into return inlets.

⚠ CAUTION For Installation of Electrical Controls at Equipment Pad (ON/OFF Switches, Timers and Automation Load Center)



Install all electrical controls at equipment pad, such as on/off switches, timers, and control systems, etc. to allow the operation (startup, shut-down, or servicing) of any pump or filter so the user does not place any portion of his/her body over or near the pump strainer lid, filter lid or valve closures. This installation should allow the user enough space to stand clear of the filter and pump during system start-up, shut down or servicing of the system filter.

⚠ DANGER HAZARDOUS PRESSURE: STAND CLEAR OF PUMP AND FILTER DURING START UP.



Circulation systems operate under high pressure. When any part of the circulating system (i.e. locking ring, pump, filter, valves, etc.) is serviced, air can enter the system and become pressurized. Pressurized air can cause the pump housing cover, filter lid, and valves to violently separate which can result in severe personal injury or death. Filter tank lid and strainer cover must be properly secured to prevent violent separation. Stand clear of all circulation system equipment when turning on or starting up pump. Before servicing equipment, make note of the filter pressure. Be sure that all controls are set to ensure the system cannot inadvertently start during service. Turn off all power to the pump. **IMPORTANT: Place filter manual air relief valve in the open position and wait for all pressure in the system to be relieved.**

Before starting the system, fully open the manual air relief valve and place all system valves in the "open" position to allow water to flow freely from the tank and back to the tank. Stand clear of all equipment and start the pump.

IMPORTANT: Do not close filter manual air relief valve until all pressure has been discharged from the valve and a steady stream of water appears. Observe filter pressure gauge and be sure it is not higher than the pre-service condition.

General Installation Information

- All work must be performed by a qualified service professional, and must conform to all national, state, and local codes.
- Install to provide drainage of compartment for electrical components.
- These instructions contain information for a variety of pump models and therefore some instructions may not apply to a specific model. All models are intended for use in swimming pool applications. The pump will function correctly only if it is properly sized to the specific application and properly installed.

⚠ WARNING Pumps improperly sized or installed or used in applications other than for which the pump was intended can result in severe personal injury or death. These risks may include but not be limited to electric shock, fire, flooding, suction entrapment or severe injury or property damage caused by a structural failure of the pump or other system component.

Pumps and replacement motors that are single speed and one (1) Total HP or greater cannot be sold, offered for sale, or installed in a residential pool for filtration use in California, Title 20 CCR sections 1601-1609.

CUSTOMER SERVICE / TECHNICAL SUPPORT

If you have questions about ordering Pentair replacement parts, and pool products, please contact:

Customer Service and Technical Support, USA

(8 A.M. to 4:30 P.M. — Eastern/Pacific Times)

Phone: (800) 831-7133

Fax: (800) 284-4151

Web site

Visit www.pentair.com for more information about Pentair products.*

Sanford, North Carolina (8 A.M. to 4:30 P.M. ET)

Phone: (919) 566-8000

Fax: (919) 566-8920

Moorpark, California (8 A.M. to 4:30 P.M. PT)

Phone: (805) 553-5000 (Ext. 5591)

Fax: (805) 553-5515

TABLE OF CONTENTS

Important Pump Warning and Safety Instructions	i	Operation	4
Installation	1	Pressure Test	4
Location	1	Priming the Pump	4
Piping	1	Draining Pump	4
Thread Taping Instructions	1	Winterizing	5
Fittings	1	Start-up for Winterized Equipment	5
Suction Requirements	2	Performance Curves	5
Suction Outlet Covers	2	Maintenance	6
Testing and Certification	2	Cleaning the Strainer Basket	6
Water Velocity	2	Pump Disassembly/Removing Old Seal	6
Electrical Installation	3	Pump Reassembly/Installing New Seal	7
Wiring	3	Troubleshooting	8
Grounding	3	Replacement Parts	9
Bonding	3		

* Translated versions of this manual are available online at / La versión en español de este manual del producto, se puede encontrar en línea a : https://www.pentair.com/en/products/pool-spa-equipment/pool-pumps/max-e-pro_high_efficiencypoolandspapumps.html

INSTALLATION

WARNING

Trapped air in the system can cause permanent equipment damage. Ensure all air is relieved from the system before operating, testing or servicing the equipment.

CAUTION

Do NOT connect system to a high pressure or city water system.

Location

Only qualified, licensed personnel should install the pump and pump wiring.

Be sure the Max-E-Pro® Pool and Spa Pump equipment pad or plumbing meets the following requirements:

- Pump mount must be solid, level, rigid and minimize vibration. To reduce vibration and stress to piping, bolt the pump to the equipment pad.
- Allow for enough ventilation to maintain air temperature at less than the maximum ambient temperature rating listed on the motor nameplate.
- If installed in an enclosure/pump house, the enclosure must have adequate ventilation and air circulation to keep the temperature inside the enclosure at or below the maximum rated ambient temperature when the pump is running.
- Locate away from corrosive or flammable liquids.
- Suction port should be as close to water level as possible.
- To reduce friction losses use short, straight suction pipe.
- Allow for gate valves in both the suction and discharge piping.
- Provide adequate floor drainage to prevent flooding and protect the pump from excess moisture.
- Allow adequate access for servicing pump and piping.

Port Threads:

Internal - 2" NPT for direct connection to pipe. External - 3-1/4" Buttress. Fits P/N U11-200P Union Collar for quick disconnect.

See parts list on page 9 for Union Kit part numbers.

Figure 1

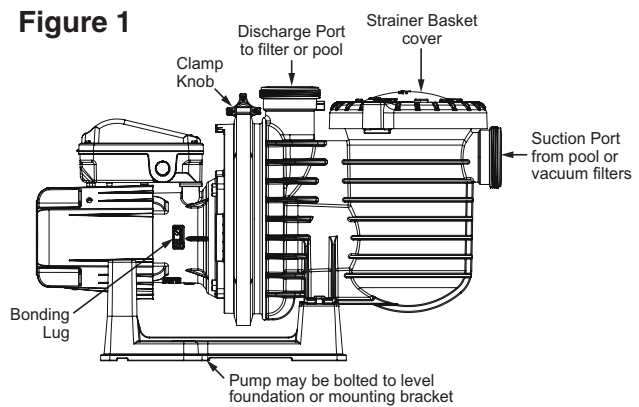

Piping

1. Use at least 2" (51mm) pipe. Increase size if a long run is needed.
2. Support both the suction and discharge piping independently, placing these supports as close to the pump as possible. This will prevent unnecessary strain on the pump.
3. During piping installation, start all piping and run the pipe away from the pump. This will prevent strain caused by a gap at the last connection.
4. Slope suction pipe slightly upward toward the pump to prevent airlocking.
5. To prevent flooding when removing the pump for service, all flooded suction systems must have a gate valve in both the suction and discharge pipes.
6. For most installations Pentair recommends installing a valve on both the pump suction and return lines so that the pump can be isolated during routine maintenance. However, we also recommend a valve, elbow or tee installed in the suction line should be no closer to the front of the pump than five (5) times the suction line diameter.

Example: A 2 inch pipe requires a 10 inch (25.4 cm) straight run in front of the suction inlet of the pump. This will help the pump prime faster and last longer.

Note: Do not install 90° elbows directly into the pump inlet or outlet.

Taping Instructions

1. If connecting threaded pipe directly to the pump, apply one or two layers of thread seal tape to the male pipe threads. Cover the entire threaded portion of the pipe.

Note: Do NOT use pipe dope; pipe dope can lead to cracking in some plastics and may damage components in the piping system.

2. If plumbing threaded pipe to the pump using unions, apply thread seal tape between the pipe and union adapter. The union collar should be installed hand-tight. Be sure the union's O-ring is seated correctly in its groove.

Note: DO NOT overtighten or tighten past the thread stops within the pump ports.

If leaks occur, remove pipe, clean off old tape, rewrap with one or two layers of new tape and reinstall the piping.

Fittings

1. Fittings restrict flow. Use the fewest number of fittings possible to maximize system efficiency.
2. Avoid fittings that could lead to air traps in suction piping.
3. Pool and spa drains must conform to International Association of Plumbing and Mechanical Officials (IAPMO) standards.
4. Use only non-entrapping suction fittings and dual suction outlets.

Pump Suction Requirements

The pump suction system must provide protection against the hazard of suction entrapment or hair entrapment/entanglement.



WARNING Pump suction is hazardous and can trap and drown or disembowel bathers. Do not use or operate swimming pools, spas, or hot tubs if a suction outlet cover is missing, broken, or loose. Follow the guidelines below for a pump installation which minimizes risk to users of pools, spas, and hot tubs.

Suction Outlet Covers

All suction outlet covers must be properly maintained. They must be replaced if cracked, broken or missing. All suction outlets must have correctly installed, screw-fastened covers in place.

Provide at least two hydraulically balanced main drains, with covers, as suction outlets for each circulating pump suction line. The centers of the main drains (suction outlets) on any one suction line must be at least three feet apart.

The system must be built so that it cannot operate with the pump drawing water from only one main drain (that is, there must be at least two main drains connected to the pump whenever it is running – see **Figure 2**). However, if two main drains run into a single suction line, the single suction line may be equipped with a valve which will shut off both main drains from the pump (see **Figure 2**).

More than one pump can be connected to a single suction line as long as the requirements above are met.

Testing and Certification

Suction outlet covers must have been tested by a nationally recognized testing laboratory and found to comply with the latest ANSI/ASME Specifications for Suction Fittings For Use in Swimming Pools, Spas, Hot Tubs, and Whirlpool Bathtub Applications.

Water Velocity

The maximum water velocity through the suction fitting or cover for any suction outlet must not exceed 1.5 feet per second unless the outlet complies with the latest ANSI/ASME Specification for Suction Fittings For Use in Swimming Pools, Spas, Hot Tubs, and Whirlpool Bathtub Applications. In any case, do not exceed the suction fitting's maximum designed flow rate.

If 100% of the pump's flow comes from the main drain system, the maximum water velocity in the pump suction hydraulic system must be six feet per second or less even if one main drain (suction outlet) is completely blocked. The flow through the remaining main drain(s) must comply with the latest ANSI/ASME Specification for Suction Fittings For Use in Swimming Pools, Spas, Hot Tubs, and Whirlpool Bathtub Applications.

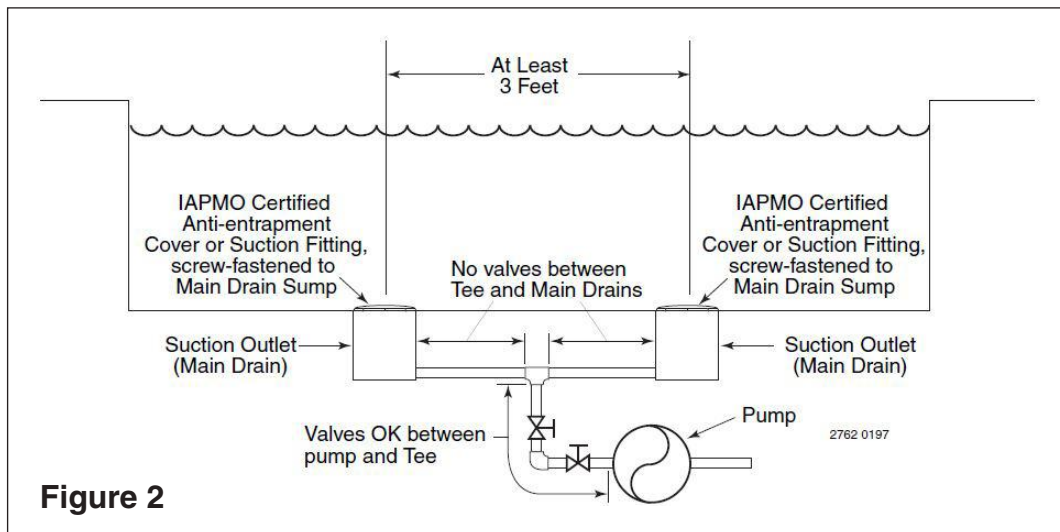

Electrical Installation

⚠ WARNING



RISK OF ELECTRICAL SHOCK OR ELECTROCUTION. This pump must be installed by a licensed or certified electrician or a qualified service professional in accordance with the National Electrical Code (NEC) and all other applicable national or local codes and ordinances. Improper installation will create an electrical hazard which could result in death or serious injury to users, installers, or others due to electrical shock, and may also cause damage to property.

Always disconnect power to the pump at the circuit breaker before servicing the pump. Failure to do so could result in death or serious injury to service people, users or others due to electric shock.

Read all servicing instructions before working on the pump.

Wiring

1. Before wiring the pump, ensure all power on the pump's circuit is turned off at the circuit breaker.

⚠ WARNING

STORED CHARGE - Wait at least 60 seconds before servicing.

2. Become familiar with the wiring diagram and electrical specifications of your particular pump motor. This information is provided on the motor nameplate label found on the side of the motor.
3. Ensure the supply voltage meets the requirements listed on the motor nameplate label. If these requirements are not met, permanent motor damage may occur.
4. For wiring sizes and general guidelines for proper electrical installation, follow the specifications defined in the National Electrical Code and all other applicable national or local codes.
5. 3-Phase motors require external overload protection. An initial inspection is needed to ensure proper rotation of the pump.
Once installed, momentarily cycle the power on and then off. Note the rotation of the motor fan or shaft as it comes to a stop. If wired correctly the motor shaft and/or fan will match the rotation arrow noted on the pump.
6. Use a strain relief and ensure all electrical connections are clean and tight.
7. Cut all wires to the appropriate length so they do not overlap or touch when connected.

Grounding

1. Permanently ground the motor using the green ground screw. Use the correct wire size and type specified by National Electrical Code. Ensure the ground wire is connected to an electrical service ground.
2. The pump should be permanently connected to either a circuit breaker, 2-pole timer or 2-pole relay.

Note: If power is supplied by a GFCI circuit breaker, the pump should be wired on its own independent circuit **unless the pump is operated in tandem with a Pentair salt chlorine generator.**

Bonding

1. Bond the motor to the structure in accordance with the National Electrical Code and all other applicable national or local codes. Use a solid copper bonding conductor not smaller than 8 AWG. For Canadian installations, a 6 AWG or larger solid copper bonding conductor is required. Run a wire from the pump's bonding screw or lug to the bonding structure.
2. Connect the bonding wire to all metal parts of the pool structure and to all electrical equipment, metal conduit and metal piping within 5 ft. (1.5 m) of the inside walls of the pool. Run a wire from the external bonding screw or lug to the bonding structure.

⚠ WARNING

Before establishing or restoring power to the pump, be sure all electrical connections are tight and all electrical and wiring compartment covers are properly installed.

Note: When the pump is started and stopped by removing power with a relay or timer, a two-pole device should be used to apply and remove power to both POWER LINE TERMINALS. Pentair offers GFCI breakers which offer appropriate personal protection while meeting 2008 to current NEC Standards for Pool Pumps. See Pentair product catalog for details.

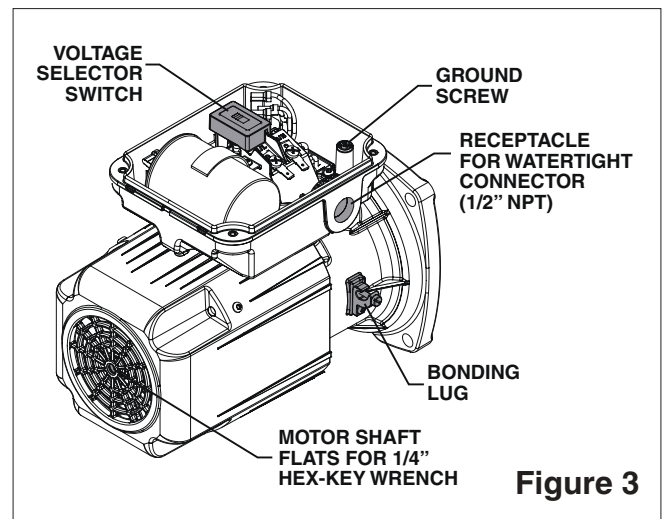

Figure 3

OPERATION

⚠ CAUTION

DO NOT run the pump dry. If the pump is run dry, the mechanical seal will be damaged and the pump will start leaking. If this occurs, the damaged seal must be replaced. ALWAYS maintain proper water level. If the water level falls below the suction port, the pump will draw air through the suction port, losing the prime and causing the pump to run dry, resulting in a damaged seal. Continued operation in this manner could cause a loss of pressure, resulting in damage to the pump case, impeller and seal and may cause property damage.

Pressure Test

Before performing pressure tests on the system, make the following safety checks:

1. Be sure all clamps, bolts, lids and system accessories are properly and tightly installed.
2. Release all pressure in the system.
3. Water pressure during test must not exceed 25 PSI (7.5 kg/cm²).
4. Water temperature during test must not exceed 100°F (38°C).
5. Limit pressure test to 24 hours. After test, visually inspect the system to ensure it is ready for operation.

Priming the Pump

⚠ WARNING

DO NOT open the strainer pot if pump fails to prime or if pump has been operating without water in the strainer pot. Pumps operated in these circumstances may experience a build up of vapor pressure and may contain scalding hot water. Opening the pump may cause serious personal injury. In order to avoid the possibility of personal injury, make sure the suction and discharge valves are open and strainer pot temperature is cool to touch, then open with extreme caution.

1. Relieve all air from filter and piping system. See the filter owner's manual for correct procedure.
2. In a flooded suction system (water source higher than the pump), the pump will prime itself when suction and discharge valves are opened.
3. If pump is not in a flooded suction system, unscrew and remove strainer cover; fill strainer and pump with water.
4. Clean and inspect O-Ring; reinstall on strainer groove.

Note: Do not lubricate the strainer lid O-Ring. The original equipment O-Ring contains a permanent internal lubricant.

Note: If you replace the O-Ring with a non-internally lubricated O-Ring, you may need to apply a silicone based lubricant.

5. Replace strainer lid, turning clockwise to tighten the cover. Hand tighten only.
6. Pump should now prime. Priming time will depend on vertical length of suction lift and horizontal length of suction piping.
Note: If pump does not prime, make sure that all valves are open, suction pipe end is under water, and that there are no leaks in suction pipe. See *Troubleshooting*, page 8.

Draining the Pump

⚠ WARNING

SEPARATION HAZARD! Purging the system with compressed air can cause components to separate, with risk of severe injury or death to anyone nearby. Use only a low pressure (below 5 PSI), high volume blower when air purging the pump, filter, or piping.

1. Pump down the pool, spa or hot tub water level below all inlets.

⚠ WARNING

HAZARDOUS VOLTAGE! To avoid dangerous or fatal electrical shock hazard, turn OFF power to the motor at the circuit breaker before draining the pump.

2. Remove strainer lid (turn counterclockwise). If necessary, tap handles gently with a rubber mallet. Low pressure air can be used to remove remaining water from the piping.
Note: Lugs have been provided on the trap lid to use a lever or pry bar for loosening.
3. Cap inlet piping after draining to keep water out of the pipes.
4. To prevent pump from freezing, remove strainer lid and drain the pump through the drain plugs provided.
 - Gravity drain system as far as possible.
 - Protect areas which retain water with non-toxic propylene glycol antifreeze ("RV" antifreeze).
5. Clean pump and strainer basket thoroughly; replace strainer lid.
6. Be sure motor is kept dry and covered.

Winterizing

⚠ CAUTION

Allowing the pump to freeze will damage pump and void warranty.

⚠ CAUTION

Do not use anti-freeze solutions (except propylene glycol) in your pool/spa system. Propylene glycol, "RV antifreeze", is non-toxic and will not damage plastic system components; other anti-freezes are highly toxic and may damage plastic components in the system.

1. Drain all water from pump and piping when expecting freezing temperatures or when storing pump for a long time (see instructions below).
2. Keep motor dry and covered during storage.
3. To avoid condensation/corrosion problems, do not cover pump with plastic.

For outdoor/unprotected installations:

1. Gravity drain system as far as possible.
2. Protect areas which retain water with non-toxic propylene glycol antifreeze ("RV antifreeze").
3. Enclose entire system in a weatherproof enclosure.
4. To avoid condensation/corrosion damage, allow ventilation; do not wrap system in plastic.
5. Use a 40% propylene glycol/60% water solution to protect pump to -50°F (-46°C).

Start-up for Winterized Equipment

1. Remove any temporary weather protection placed around system for shutdown.
2. Follow filter manufacturer's instructions for reactivation of the filter.
3. Inspect all electrical wiring for damage or deterioration over the shutdown period. Have a qualified serviceman repair wiring as needed.
4. Inspect and tighten all watertight connections.
5. Open all valves in suction and return piping.
6. Remove any winterizing plugs in piping system.
7. Drain all antifreeze from system.
8. Close all drain valves and replace all drain plugs in piping system.
9. Prime pump according to *Priming the Pump* on page 4.

Performance Curve

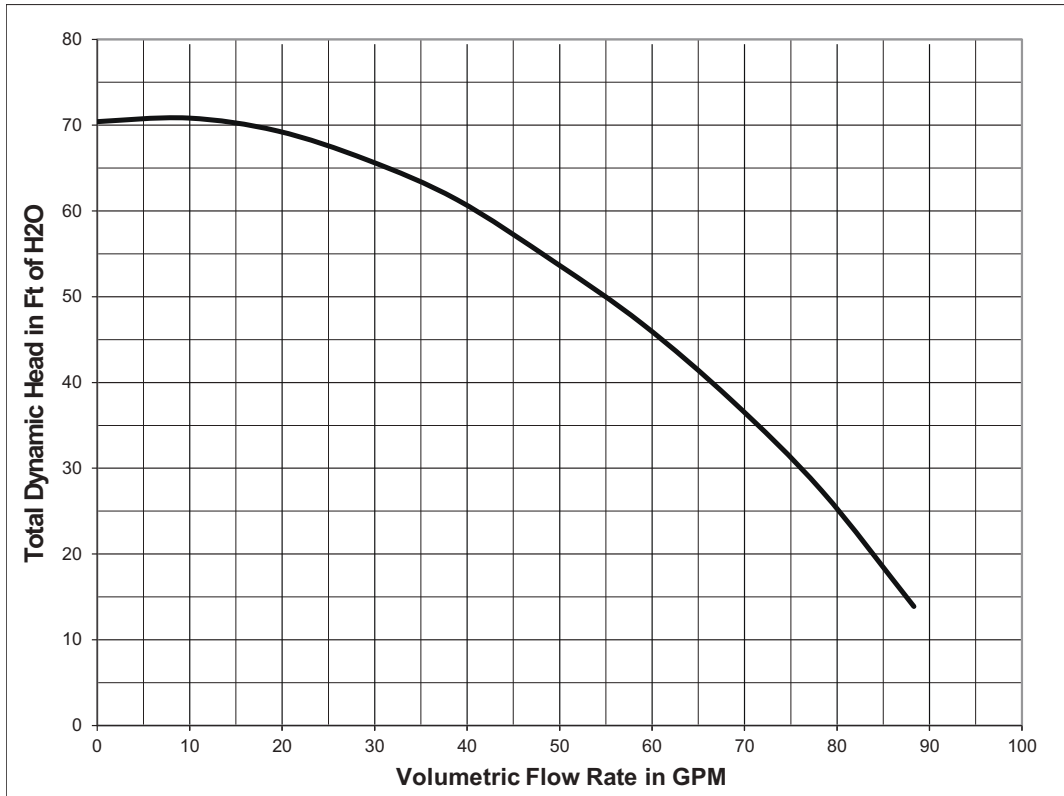

MAINTENANCE

⚠ WARNING



This pool pump must be installed by a licensed or certified electrician or a qualified pool serviceman in accordance with the National Electrical Code and all applicable local codes and ordinances. Improper installation will create an electrical hazard which could result in death or serious injury to pool users, installers, or others due to electrical shock, and may also cause damage to property.

Always disconnect power to the pool pump at the circuit breaker before servicing the pump. Failure to do so could result in death or serious injury to serviceman, pool users or others due to electric shock.

Read all servicing instructions before working on the pump.

Cleaning the Strainer Basket

The only routine maintenance needed is inspection/cleaning of the strainer basket. Debris or trash that collects in the basket will choke off water flow through the pump. Follow the instructions below to clean the strainer basket:

1. Disconnect power to the pump at the circuit breaker.
2. Close all gate valves in the suction and discharge lines.
3. Release all pressure from the pump and piping system.
4. Remove strainer lid (turn counter-clockwise). If necessary, tap handles gently with a rubber mallet.
5. Remove the strainer basket and clean. Be sure all holes in basket are clear.
6. Flush basket with water and place back into the strainer pot.

Note: Ensure the large opening in the basket is oriented towards the pipe connection port (between ribs provided). If the basket is replaced backwards the lid will not fit on the strainer pot.

7. Clean and inspect the lid O-Ring and reinstall on strainer groove.
8. Clean the O-Ring groove on the strainer pot and reinstall the lid/locking ring.

Note: To prevent sticking, hand tighten only.

9. Prime the pump (see *Priming the Pump*, page 4).

Pump Disassembly / Removing Old Seal

1. Disconnect power to the pump at the circuit breaker.
2. Close all gate valves in the suction and discharge lines.
3. Release all pressure from the pump and piping system.
4. Drain the pump by removing the drain plugs at the bottom of the strainer pot.
5. Remove the band clamp that holds the pump halves together. The motor and seal plate assembly can now be pulled away from pump body.
6. Remove the five (5) screws securing the diffuser to the seal plate. Remove the diffuser.
7. Hold the motor shaft, at the back of the motor, with a 1/4" hex-key wrench.
8. Unscrew the impeller from the motor shaft (turning counterclockwise when facing the impeller).
9. Remove the rotating seal member from the motor shaft.
10. Remove the four (4) screws securing the seal plate to the motor.
11. Place seal plate face down on a flat surface and tap out white ceramic seal (see **Figure 4**).
12. Clean the seal plate's seal cavity and the motor shaft.

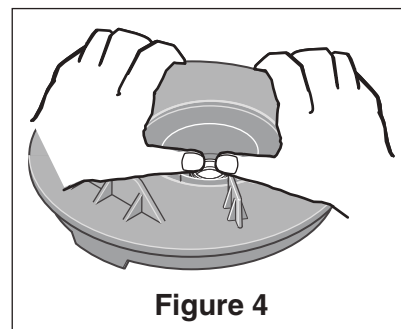

Figure 4

Pump Reassembly / Installing New Seal

IMPORTANT: The ceramic seal of the pump shaft seal must be clean and free of dirt, grease and dust before installing.

1. Wet the outer edge of the ceramic seal with a small amount of liquid detergent. Firmly and squarely press it into the seal plate cavity with your thumbs.
2. If ceramic seal does not seat properly into the seal plate cavity, remove it and place the seal face up on a flat surface. Reclean the seal plate cavity and attempt to reseat the seal.
3. If ceramic seal still will not seat correctly in the seal plate, place a cardboard washer over the ceramic seal and use a piece of 3/4" standard pipe to press the seal into place.

Note: Be sure not to scratch or mar the surface of the seal. If seal is damaged it will leak.

4. Remount the seal slate onto the motor using the four (4) motor to seal plate screws. Torque the screws to 60-80 inch-lbs. (69-92 kg/cm).
5. Apply a small amount of liquid detergent to the inside diameter of the rotating seal member.
6. Slide the rotating seal member, polished carbon face outwards, over the impeller sleeve until rubber drive ring hits the back of the impeller.

Note: Be sure not to scratch or mar the polished seal face. The seal will leak if damaged.

7. Screw the impeller onto the motor shaft clockwise. The impeller will correctly seat the rotating seal member into the seal plate.
8. Mount the diffuser onto the seal plate with the five (5) screws. Torque screws to 10-14 inch/lbs. (11.2-16.1 kg/cm).
9. Assemble the motor and seal plate to the pump body by reinstalling the band clamp.

Note: The clamp knob can be located in any position around the volute. If it is moved after assembly, tighten knob while tapping around clamp to assist sealing. DO NOT move the clamp while the pump is full of water.

10. Reinstall the drain plug into the bottom of the pump body.
11. Open all gate valves in the suction and discharge lines.
12. Reconnect power to the pump at the circuit breaker.
13. Prime the pump according to *Priming the Pump*, on page 4.

TROUBLESHOOTING

Read and understand all safety and operating instruction in this manual before servicing the pump.

Only qualified personnel should electrically test the pump motor.

Problem	Possible Cause	Corrective Action
Failure to Pump Water; Reduced Capacity or Discharge Pressure	Suction leaks / lost prime	<p>Ensure pump volute and strainer basket are full of water. See <i>Priming the Pump</i> on page 4.</p> <p>Inspect for leaks in the suction piping.</p> <p>Ensure suction pipe inlet is well below the water level to prevent pump from sucking air.</p> <p>Suction lift of 10 to 20 feet (3-6 m) will reduce performance. Suction lift of more than 20 feet (6 m) will prevent pumping and cause pump to lose prime. In either case, move pump closer (vertically) to water source. Make sure suction pipe is large enough.</p>
	Clogged pipe or impeller, or worn impeller/diffuser	<p>Ensure the strainer pot/basket is not clogged. If it is, clean the basket and pot.</p> <p>Ensure impeller is not clogged. Disassemble the pump according to <i>Pump Disassembly</i>, on page 6. If a blockage in the impeller is found clear the blockage and reassemble the pump according to <i>Pump Reassembly</i>, on page 7.</p> <p>Inspect the impeller and diffuser for wear. If either shows sign of damage or major wear, order replacement parts listed in the <i>Parts List</i> (page 9).</p> <p>Pump may be trying to push too high a column of water. If so, a “higher head” pump is needed.</p>
	Electrical issue	<p>Pump may be running too slowly. Check voltage at motor terminals and at the meter while pump is running. If low, see wiring instruction or consult power company.</p> <p>Inspect for loose electrical connections.</p> <p>Pump may be too hot.</p> <ol style="list-style-type: none"> Check line voltage. If less than 90% or more than 110% of rated voltage, consult a licensed electrician. Increase ventilation to the pump. Reduce ambient temperature. Tighten any loose electrical connections.
Mechanical Trouble and Noise	Suction and/or discharge piping are not properly supported	See <i>Piping</i> , on page 1, for plumbing installation requirements and recommendations.
	Pump is not properly mounted	Pump should be securely mounted to a concrete platform.

REPLACEMENT PARTS

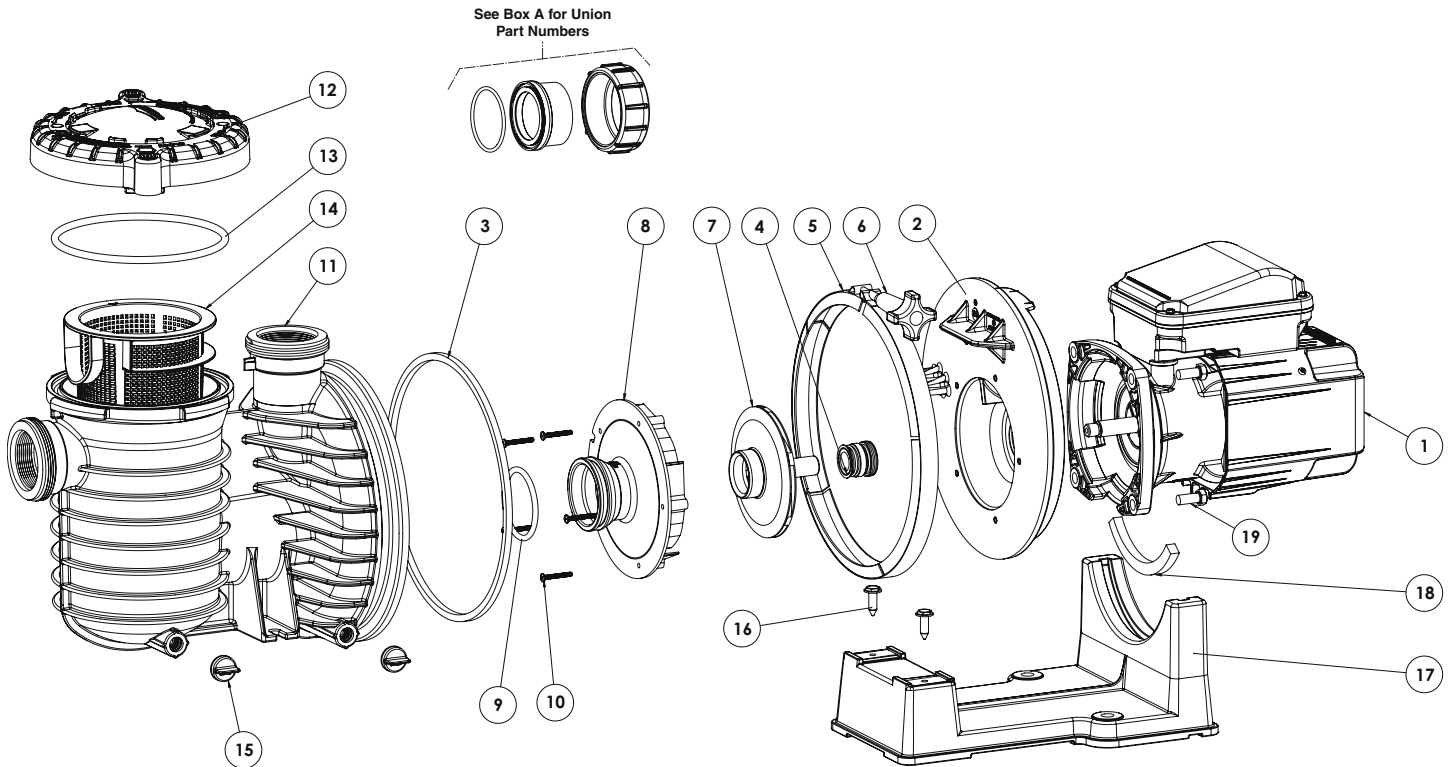

Item #	Part #	Part Description	Qty.
1	356362S	Motor	1
2	C203-194P	Seal Plate Kit (Incl. Item# 3-4)	1
3	357099	Gasket, Seal Plate to Housing	1
4	17351-0101S	Shaft Seal	1
5	C19-37A	Band Clamp	1
6	WC36-22	Band Clamp Knob	1
7	C105-238PDOEZ	Impeller	1
8	356359Z	Diffuser	1
9	357098Z	Diffuser O-Ring (Blue Coating)	1
10	357841Z	Diffuser Screw Kit	1
11	17307-0110S	Trap Body Assembly (Incl. Item# 12-15)	1
12	17307-0111S	Trap Cover Assembly (Incl. Item# 12-13)	1
13	35505-1440	Trap O-Ring	1

Item #	Part #	Part Description	Qty.
14	C8-58P	Basket	1
15	U178-920P	Drain Plug, 1/4" NPT	2
16	U30-918SS	Base Screw	2
17	C4-79P	Base	1
18	C35-43	Motor Pad	1
19	U30-74SS	Screw, 3/8-16 x 1" Hex Head	4
-	357810	Fan Guard Kit	1

(-) Note: Not shown

Box A

For quick disconnect pipe connections, purchase separately:
 Pkg. 188 2" Slip 1/2 Union Kit or
 Pkg. 189 2" NPT 1/2 Union Kit.

Kit Includes:

U11-200P Union Collar
 U9-362 O-Ring
 U11-196P 2" Slip adapter OR
 U11-199P 2" NPT adapter.

NOTES

NOTES



1620 HAWKINS AVE., SANFORD, NC 27330 • (919) 566-8000
10951 WEST LOS ANGELES AVE., MOORPARK, CA 93021 • (805) 553-5000

WWW.PENTAIR.COM

All indicated Pentair trademarks and logos are property of Pentair. Third party registered and unregistered trademarks and logos are the property of their respective owners. Because we are continuously improving our products and services, Pentair reserves the right to change specifications without prior notice.

© 2021 Pentair. All rights reserved. This document is subject to change without notice.



P/N 356990 REV. B 3/1/21