



Project _____

AIA# _____ SIS# _____

Item # _____ Quantity _____

MASTER SERIES

Full-Size Gas Hot Plates



Model PCV-4

The images presented here are illustrative and may vary or not exactly match the physical product.



DESCRIPTION

Coriat Master Series Full-Size Gas Hot Plates are specially designed as central elements in regular kitchens or as auxiliary devices in very large kitchens. They are useful for simultaneously cooking on frying pans, saucepans, cocottes and brasiers.

SPECIFY TYPE OF GAS WHEN ORDERING

- Natural Gas
- Propane

SPECIFY ALTITUD

Above 2,000 ft

MODELS

- PCV-2
- PCV-6
- PCV-4
- PCV-8

STANDARD FEATURES

- External and internal sheet metal parts in stainless steel.
- Heavy duty removable cast iron top grates.
- "Drop in" stainless steel burner drip pan, to retain spills.
- Removable stainless steel crumb tray, for fast cleaning.
- 24,000 Btu/h solid cast iron open burners.
- Individual stainless steel no clog pilots.
- Independent manual controls for each burner.
- Zamak die cast knobs with set screws.
- Gas pressure regulator.
- Stainless steel adjustable legs.
- CSA design certified, NSF listed.

ACCESORIES

Equipment Stand Size

- 11 1/2"
- 34 1/2"
- 23"
- 46 1/2"

MASTER SERIES - Full-Size Gas Hot Plates

Approved by _____ Date _____ Approved by _____ Date _____



MASTER SERIES

Full-Size Gas Hot Plates

CLEARANCE AND POSITIONING REQUIREMENTS

This product must be installed on a non-combustible surface only, with a minimum of 6" from all sides. There must be a clearance of at least 6" from another appliance. This unit is supplied with 4 legs and must be placed on a resistant non-slip surface.

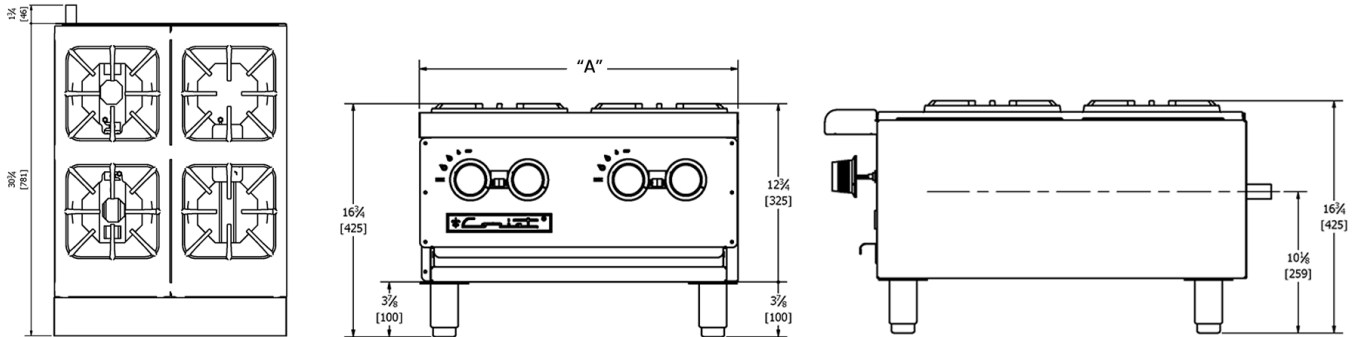

Model	Width (A)	Depth	Overall Height	Working Height	Working Area	Burners	BTU/HR	Shipping Weight (Lbs/Kg)
PCV-2	11 5/8"	30 3/4"	16 3/4"	16 1/8"	11 5/8" x 26 3/4"	2	48,000	101/46
PCV-4	23 1/4"	30 3/4"	16 3/4"	16 1/8"	23 1/4" x 26 3/4"	4	96,000	168/76
PCV-6	34 5/8"	30 3/4"	16 3/4"	16 1/8"	34 5/8" x 26 3/4"	6	144,000	231/105
PCV-8	46 1/2"	30 3/4"	16 3/4"	16 1/8"	46 1/2" x 26 3/4"	8	192,000	291/132

Constant improvement in all our processes is a Coriat value, therefore some specifications are subject to change without notice.

Approved by _____ Date _____ Approved by _____ Date _____