

2019-2024 RAM 1500 DT, REBEL

DITCH LIGHT BRACKET SET

130198

INSTALLATION INSTRUCTIONS

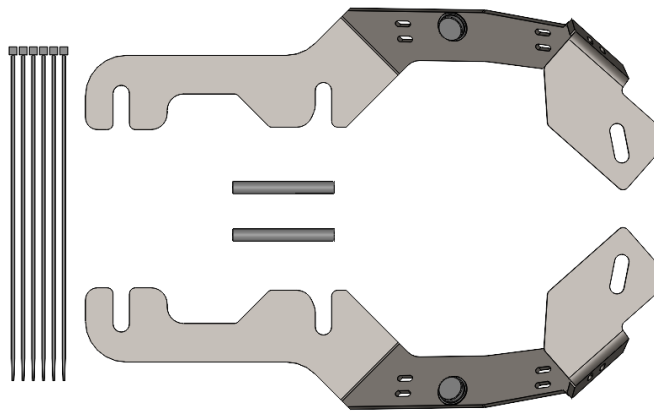

SAFETY

Your safety is extremely important to us. Working on vehicles has ever-present hazards which require precautions at all times to avoid injury or death. We've outlined some precautions to take below in order to help you make informed decisions about your safety before installing this product. This is not an exhaustive list, and you must use your own good judgment before performing any work in each step of this installation.

ALWAYS:

- wear eye protection
- use tire blocks and emergency brake
- disconnect battery(s)
- use care when moving components
- route electrical cables away from moving parts
- identify all pinch points
- wear gloves
- identify slipping and tripping hazards
- wear steel toe footwear
- understand proper use of tools before use
- work on a flat surface
- use care when lifting components
- insulate cables
- jack your vehicle from the OEM's lifting points
- torque all fasteners to suggested specs
- remove any hazards before starting on the job

LIABILITY

All liability for installation and use of this product rests with the owner. Improper installation, maintenance, and operation can result in serious injury or death as well as equipment or vehicle damage. Use this product at your own risk

KIT COMPONENTS

130198 – HOOD DITCH LIGHT BRACKET ASSEMBLY

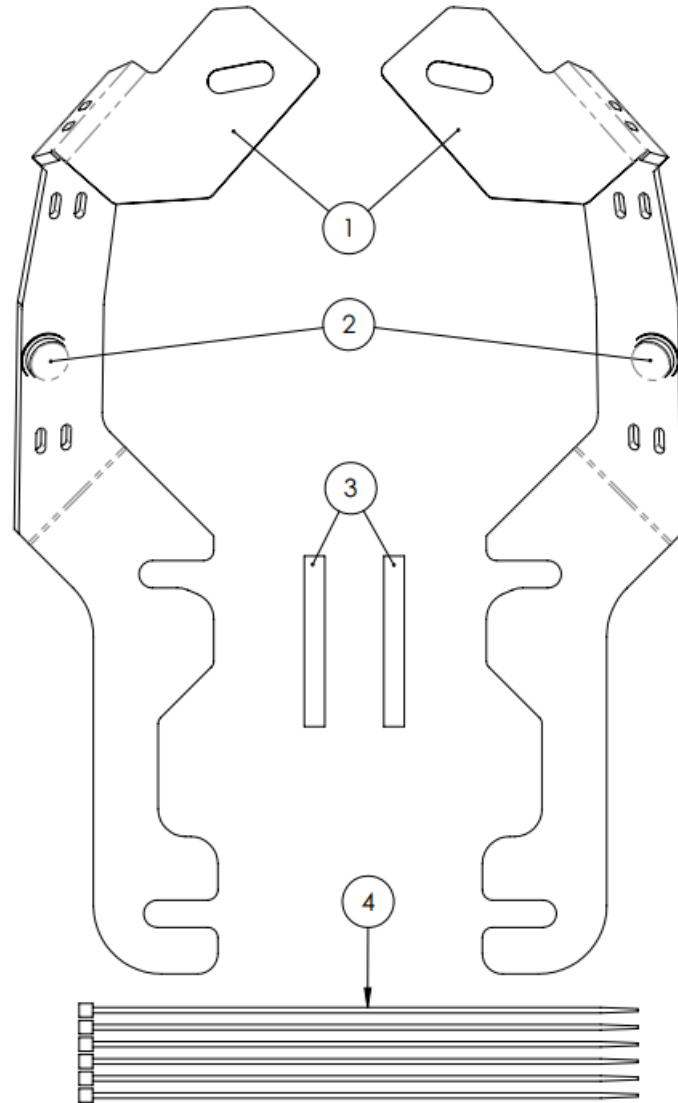

ITEM NO.	PART NUMBER	DESCRIPTION	QTY.
1	100213	Hood Ditch Light Bracket, PAIR, 2019-2024 RAM 1500 Rebel, 5th Gen	1
2	200112	Adhesive Polyurethane Rubber Bumper, 3/4" OD, 3/16"	2
3	200111	EPDM Rubber Trim, 1/8 Wide x 2.5 long	2
4	200109	Black Zap Strap, 8 Inch	6

SET UP

1. Read this entire document before performing any work.
2. Ensure you have all the parts and hardware shown in Kit Components.
3. Gather the tools required, outlined in **Table 1**.

Table 1

Tool List	
○	13mm socket, 13mm Wrench
○	Flush Cutters (or side cutters)

4. Open and assemble your LED Lights. The Vivid Lumen FNG-3 Lights easily assemble thanks to threaded holes. First put the 8mm hardware in the bracket, and attach the bracket to the light using the provided hardware and Allen key. Attach the Light to the top slot in the Ditch Light Bracket, leaving it finger tight for future adjustment.
5. Route the light power cables along the backside of the bracket. Leaving enough room for the light to move, secure the wire it to the bracket using the provided zip ties at the locations shown in Figure 1.



Figure 1



Figure 2

6. Park your truck on a flat surface and apply the parking brake. Pop the hood.
7. Mark the position of the hood hinges, relative to the hood, using a piece of painters tape or a fine tip marker (Figure 2)
8. Install the provided rubber trim on the edge of the hood (windshield side) where the brackets will protrude through the hood.

9. Starting with the passenger side, loosen (but do not fully remove) the 2 nuts that secure the hood to the hinge (Green Arrows, Figure 2)
10. Insert the bracket assembly between the gap in the hood and windshield, and slide the bracket between the flanged nut and the hood hinge. Align the hood bracket with the mark you made in Step 7 and slowly tighten nuts, alternating between them.
11. Repeat this process for the driver's side, making sure the bracket is inserted between the washer fluid line and hood.
12. Connect the lights with a wiring kit (sold separately). See our website for pre-made kits we offer.
13. Tuck the light wires between the foam hood seal and cowl (Yellow Arrow, Figure 2).
14. Slowly close the hood, making sure that the wires clear the hood hinge or any other pinch points when closed. Adjust if needed.
15. Turn on lights and adjust light beam to desired position. Tighten down the light to the bracket using a 13mm wrench.
16. Enjoy your next adventure, keepin' the ditch on either side!