

## 2019-2022 RAM REBEL AND 1500

# RECOVERY HOOK MOUNTING KIT

## INSTALLATION INSTRUCTIONS

Your safety is extremely important to us. Working on vehicles has ever-present hazards which require precautions at all times to avoid injury or death. We've outlined some precautions to take below in order to help you make informed decisions about your safety before installing this product. This is not an exhaustive list, and you must use your own good judgment before performing any work in each step of this installation.



### ALWAYS:





- wear eye protection
- use tire blocks and emergency brake
- disconnect battery(s)
- use care when moving components
- route electrical cables away from moving parts
- identify all pinch points
- wear gloves
- identify slipping and tripping hazards
- wear steel toe footwear
- understand proper use of tools before use
- work on a flat surface
- use care when lifting components
- insulate cables
- jack your vehicle from the OEM's lifting points
- torque all fasteners to suggested specs
- remove any hazards before starting on the job

### LIABILITY

All liability for installation and use of this product rests with the owner. Improper installation, maintenance, and operation can result in serious injury or death as well as equipment or vehicle damage. Use this product at your own risk.

**PARTS LIST**

100117 - REAR RECOVERY HOOK MOUNTING BRACKETS COMPONENTS		QTY
	Driver Side Recovery Hook Bracket	1
	Passenger Side Recovery Hook Bracket	1
	3/4" SCH40 Aluminum Pipe Spacer	2

RECOVERY HOOK BRACKET INSTALL HARDWARE		QTY
	M14-2.0 40mm 10.9 Flange Bolt	4
	M14-2.0 Flange Nut	3
	1/2"-13 x 1.5" YZ Flange Bolt	2
	1/2" - 13 Flange Nut	2

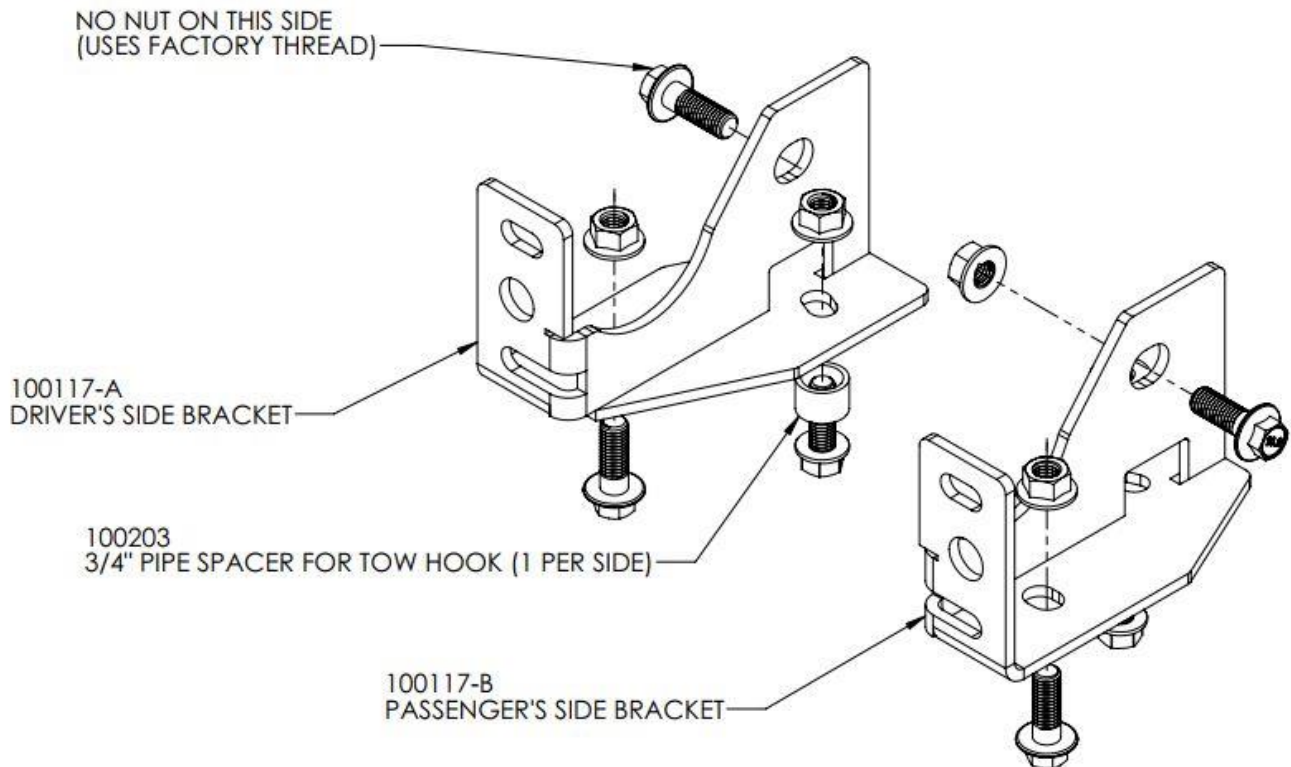

## TABLE OF CONTENTS

PARTS LIST .....	2
SET UP .....	4
FACTORY RECOVERY POINT REMOVAL .....	4
INSTALLING RECOVERY POINT ADAPTERS.....	5

**SET UP**

- Read this entire document before performing any work.
- Gather the tools required, outlined in **Table 1**.

**Table 1**

Tool List	
<input type="radio"/>	<b>Socket Set</b>
<input type="radio"/>	<b>Torque Wrench</b>
<input type="radio"/>	<b>Impact Driver (recommended)</b>

- Park your RAM on flat ground, engage the emergency brake, block the tires, and disconnect the negative battery terminal.
- Torque all 3/8" hardware to **25 ft-lbs** and all M12 and 1/2" hardware to **60 ft-lbs** and all M14 & 5/8" hardware to **90 ft lbs**.

**FACTORY RECOVERY POINT REMOVAL**

1. Remove the front body mount bolt [18mm] and second bolt [21mm] attaching the recover point in place.
  - The body mount bolts can be difficult to remove, using a mallet to hit downwards on the hook can help to free up the bolt once the threads are fully disengaged.
2. Remove the body mount bolt, leaving the rubber washer attached to the hook. Reinstall the body mount bolt and torque to spec.



**Figure 1**

3. Repeat for the second recovery point.

**Bed Step Modification [If Equipped]**

If your truck is equipped with the MOPAR bed step, some modification is required to fit both the step and recovery hook brackets.

4. Remove the bed step from the truck.



5. Trim the bottom lip off of the bed step bracket, as depicted above and circled in RED.

**INSTALLING RECOVERY POINT ADAPTERS**

4. Remove the two bumper mounting bolts on each side.



Figure 2

5. Install the recovery point adapters as depicted.
  - a. If equipped, reinstall the MOPAR bed step over top of the VICE recovery point adapter.
  - b. Tighten down the M14 then backoff 1 turn, then tighten down the bumper nuts, then go back and torque M14 and bumper nuts to spec to ensure that bracket fully seats on both faces.
6. Install supplied aluminum pipe shim in assembly as shown in Figure 5 on next page
7. Install the recovery points.



Figure 3



Figure 4

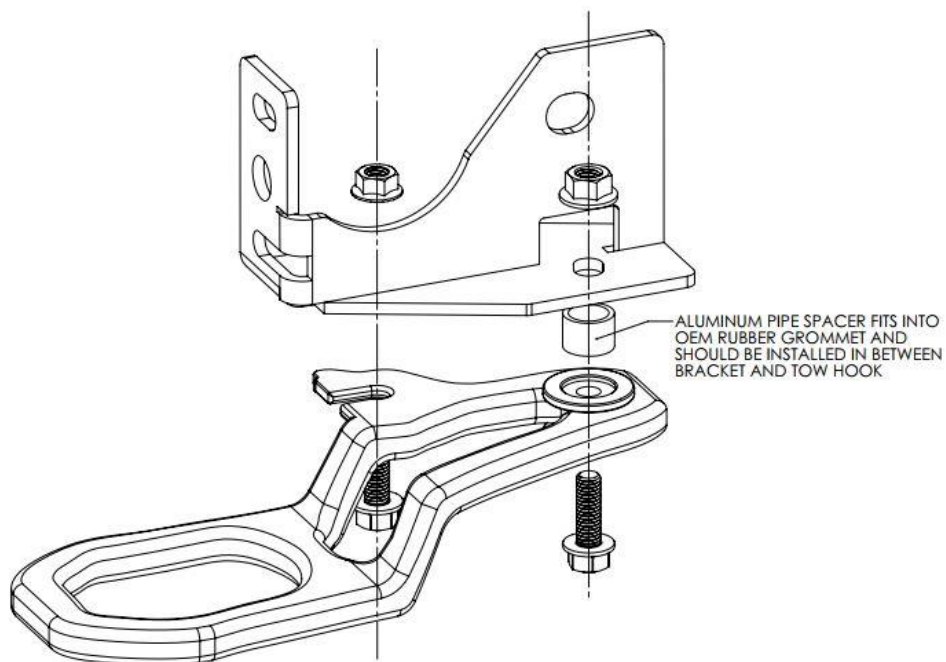

Figure 5