

2019-2023 RAM REBEL, 1500 AND TRX MOD FRONT BUMPER INSTALLATION INSTRUCTIONS

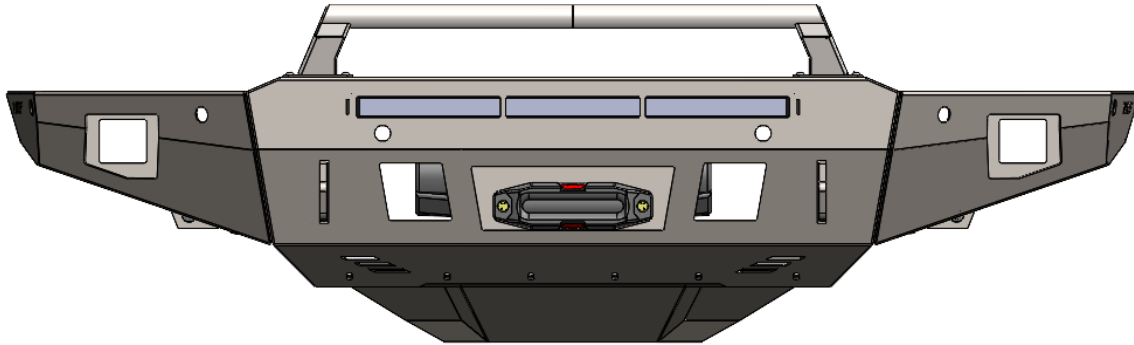

Your safety is extremely important to us. Working on vehicles has ever-present hazards which require precautions at all times to avoid injury or death. We've outlined some precautions to take below in order to help you make informed decisions about your safety before installing this product. This is not an exhaustive list, and you must use your own good judgment before performing any work in each step of this installation.

ALWAYS:

- wear eye protection
- use tire blocks and emergency brake
- disconnect battery(s)
- use care when moving components
- route electrical cables away from moving parts
- identify all pinch points
- wear gloves
- identify slipping and tripping hazards
- wear steel toe footwear
- understand proper use of tools before use
- work on a flat surface
- use care when lifting components
- insulate cables
- jack your vehicle from the OEM's lifting points
- torque all fasteners to suggested specs
- remove any hazards before starting on the job

















LIABILITY















All liability for installation and use of this product rests with the owner. Improper installation, maintenance, and operation can result in serious injury or death as well as equipment or vehicle damage. Use this product at your own risk.







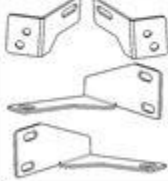







We have a companion installation video which details the installation procedure for this Bumper, we put a lot of time and energy into producing videos that are clear and helpful with a high production value. Access the video by looking us up on Youtube [[@VICE Design](#)], or scanning the QR code below.

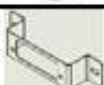

PARTS LIST

100115 (REBEL) or 100122 (1500) BASE BUMPER COMPONENTS		QTY
	Main Bumper Body (steel, bare)	1
	Driver's Side Wing (steel, bare)	1
	Passenger's Side Wing (steel, bare)	1
	1/4" Driver Side Frame Bracket (steel, bare)	1
	1/4" Passenger Side Frame Bracket (steel, bare)	1
(100162) TOW LUGS COMPONENTS		QTY
	1/2" Recovery Lugs (steel, bare)	2
	1/2" Grade 8 Carriage bolts	4
	1/2" Flange Nuts	4
BUMPER BASE INSTALL HARDWARE		QTY
	3/8"-16 x 1" Zinc Carriage Bolt	6
	3/8" Flange Nut	6
	M12x35 Zinc Carriage Bolt	10
	M12 Pushnut Bolt Retainer	6
	M12 Disc/Flange Nut	10
	M14 x 40mm Flanged Hex Bolt	2
	68335631AA Sensor Bezel (plastic, black)	2
	1" Sensor Hole Plug (plastic, black)	6

100120 - WINCH PLATE (OPTIONAL)		QTY
	1/4" Winch Mounting Plate (steel, bare)	1
	M12 x 45 mm Gr 8.8 Zinc Carriage Bolt	2
	M12 Disc/Flange Nut	2
	M12 Pushnut Bolt Retainer	2
100118 [Low Rise] or 100127 [High Rise] BULLBAR (OPTIONAL)		QTY
	Low Rise OR High Rise Bullbar (steel, bare)	1
	3/8"-16 x 3/4" SS Button Head Socket Cap Screw	8
	3/8" YZ Flat Washer	8
	3/8"-16 YZ Hex Nut	8
100129 - INTEGRATED BUMPER SKID PLATE (OPTIONAL)		QTY
	INTEGRATED BUMPER SKID PLATE (steel, bare)	1
	3/8"-16 x 3/4" SS Button Head Socket Cap Screw	6
	M8 Flange Nut	4
	3/8" U-Nut, Short	6
	M10 x 30mm Gr 10.9 Hex Flange Bolt	2
	100144 - Intercooler relocation bracket kit, 3.0L EcoDiesel [ECO DIESEL TRUCKS ONLY - NOT INCLUDED FOR GAS TRUCKS]	1
100124 - DIFFERENTIAL & STEERING SKID PLATE (OPTIONAL)		QTY
	DIFFERENTIAL & STEERING SKID PLATE (steel, bare)	1
	M10 x 30mm Gr 10.9 Hex Flange Bolt	4

OPTIONAL LIGHTING KITS		QTY
Fog Light Kit		
	525 Driving Light – DOT/SAE 10-20182A	2
	OR	
	Infinity HD Driving Light	
	H11 Fog Light Adaptors – Pair 10-30269	1
32" Light Bar Kit		
	32" Single Row Light Bar – SRS32 10-10009	1
	H1 Wiring Harness & Switch Kit 10-30030	1
100122- TRX AMBER MARKING LIGHT (TRX ONLY)		QTY
	#10-24 x 1" Button Head Hex Drive Screw	4
	#10 Washer	4
	#10-24 Hex Nut	4
	#6-32 x 1-1/4" Pan Head Phillips Screw	4
	#6 Washer	8
	#6-32 Hex Nut	4
	TRX Amber Marking Light Bracket	2
100128- TRX STOCK SKID PLATE MOUNTS (TRX ONLY)		QTY
	100128 - TRX OEM Skidplate Mounts	2
	M10 x 30mm Gr 10.9 Hex Flange Bolt	2
	M10 Flange Nut	2

5.2

TABLE OF CONTENTS

PARTS LIST	2
SET UP.....	6
FACTORY BUMPER REMOVAL	6
MOD BUMPER SET UP	8
WINCH MOUNT INSTALLATION [OPTIONAL].....	10
INSTALLING THE BUMPER	10
INSTALLING THE SKIDPLATE(s) [OPTIONAL]	12

SET UP

- Read this entire document before performing any work.
- Gather the tools required, outlined in **Table 1**.

Table 1

Tool List	
○	Socket Set
○	Flat Head Screwdriver or Plastic Pry Tool
○	Flush Cutters
○	Impact Driver (recommended)

- Park your RAM on flat ground, engage the emergency brake, block the tires, and disconnect the negative battery terminal.
- Unless otherwise noted, Torque all 3/8" steel hardware to **30 ft-lbs** and all M12 and 1/2" hardware to **65ft-lbs**.

FACTORY BUMPER REMOVAL

1. Remove the front lower fender liners by removing the 5x 8mm bolts holding them in place on both the left and right wheel well.
2. Unhook the main bumper wiring harness by locating the connector on the driver's side, right behind the fender liner which was previously removed.
 - Slide the red tab backwards
 - Push down on the black tab on the right
 - Pry open the grey latch bar, and continue until the connector halves separate

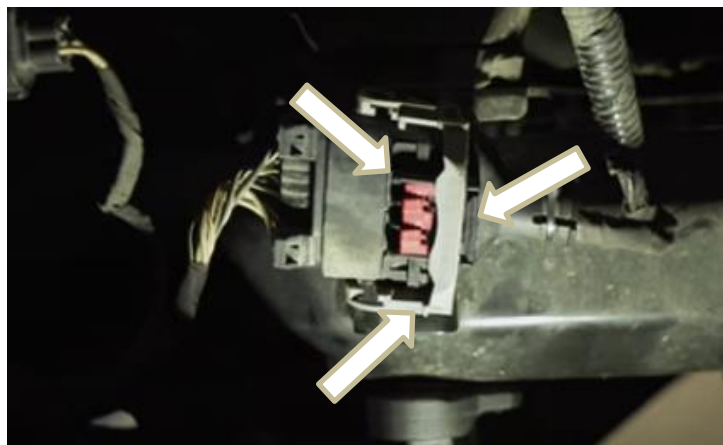

3. The factory bumper is secured to the truck using 3x 18mm nuts at the front of each frame horn. Loosen, and leave the top two nuts finger tight to prevent the bumper from falling off.
4. With a partner, remove the final two nuts and carefully tilt the top of the bumper back, while pulling the bottom of the bumper up and out. Remove the bumper from the truck.
5. Place the bumper face down somewhere convenient to work on it, to allow you to remove the parts which will be transferred over to the new VICE bumper.
6. Remove the factory sensors from the bumper (if equipped). The sensors pop out by prying open the tabs on either side and pulling the sensor out the back.
 - Leave the rubber rings on the sensors
 - To access the two center sensors the stamped steel frame mount brackets must be removed. See below.



7. Remove the rest of the harness by prying off the Christmas tree harness mounts
 - VICE recommends leaving the sensors attached to the harness
8. Remove 4 of the sensor bezels from the bumper and save, they will be used to install the sensors on the new VICE bumper.
 - The two outermost sensor bezels are molded into the bumper and cannot be removed, 2x new sensor bezels have been provided in your kit to account for these.
9. Remove the factory tow hooks by undoing the 19mm and 21mm bolts holding each in place.
 - **OPTIONAL** If reusing the tow hooks elsewhere (VICE offers a bracket kit allowing you to relocate them to the rear of your truck like the TRX's) remove the grommet that the tow hook was fastened to.
 - Ensure that the bodymount bolts are re-installed after removal of the tow hooks

MOD BUMPER SET UP

11. Have your bumper and all included steel brackets coated in the color and finish you desire. See our Recommended Coatings document for the best fit and finish for your truck!
12. Install the bumper wings highlighted blue in **Figure 1** onto the center section using 3x 3/8 carriage bolts, washers, and nuts per side. See bolts and nuts highlighted blue in **Figure 2**. Align the inside of the bumper edges so they sit flush and tighten the fasteners to about 30ft-lbs.
13. Install the lugs shown in Figure 1 using the 1/2" Gold Grad 8 carriage bolt, 2 per side, with the nut facing the center of the bumper. **Torque all 4 of these carriage bolts to 65 ft-lbs**

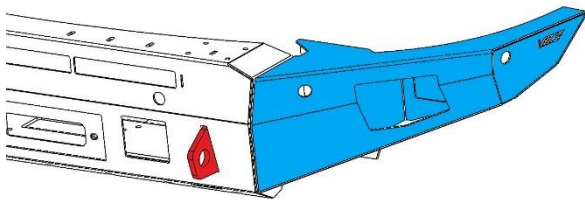

Figure 1

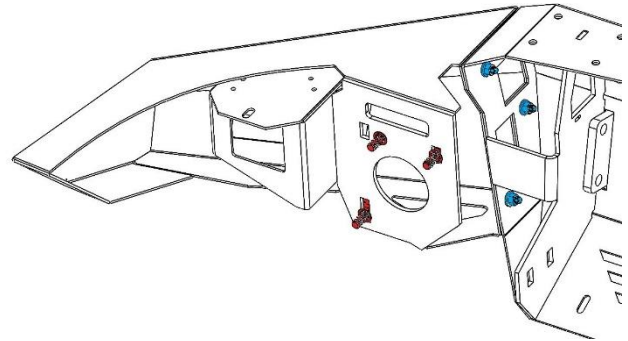

Figure 2

14. **OPTIONAL** If purchased, install the 32" light bar. Use the hardware that comes with the light bar.
15. **OPTIONAL** If purchased, install the street legal pod lights in each of the wing sections by sliding the light, harness and hardware through the front of the bumper and securing with the hardware included with the lights.
16. **OPTIONAL** If purchased, install the Ram Bar onto the top of the bumper using 8x 3/8" stainless button head fasteners and 3/8 flange nuts

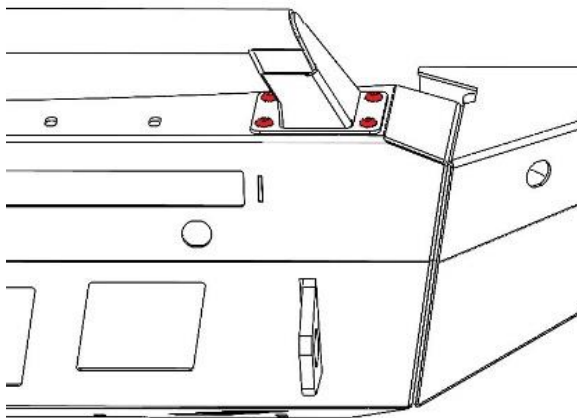

Figure 3

17. Install M12 carriage bolts into the frame plate highlighted in Figure 4 (three on each side). Use the **top** two square slots if installing on a **1500**, use the **bottom** two square slots if installing on **REBEL**. Use a 17mm deep socket to secure the provided pushnut bolt retainers and hold the bolt onto the bumper as in Error! Reference source not found.. These will make installing the bumper much easier!

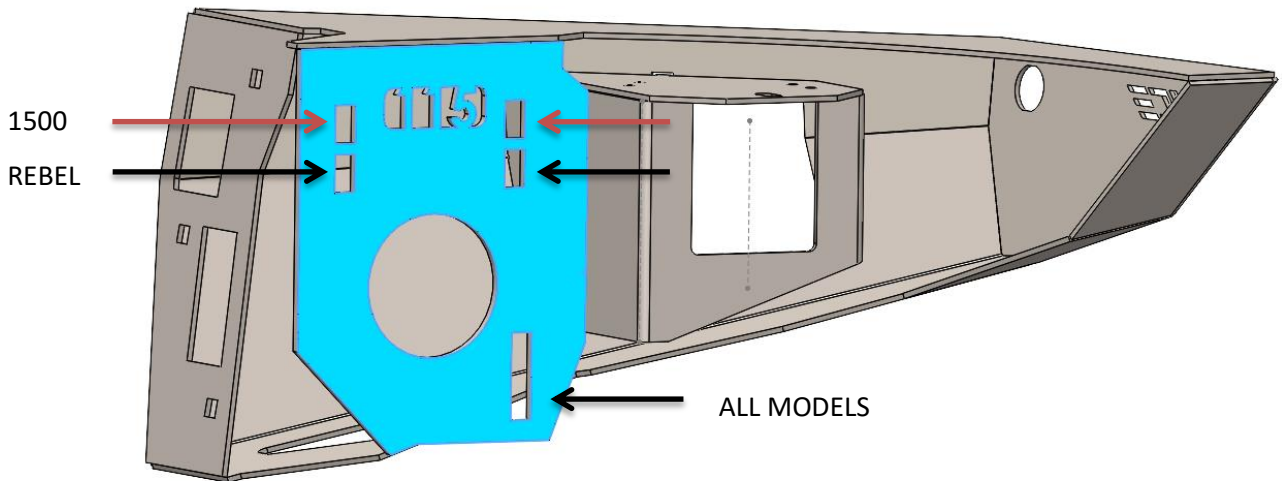

Figure 4

18. **OPTIONAL** Install the 6" round lights into the top of the bumper, using the hardware included with the lights.
19. If your truck is not equipped with factory parking sensors, install the round Flushmount blanking plugs provided into the 6 sensor holes on the bumper
20. If your truck is equipped with factory parking sensors, remove the bezels from your stock bumper and install them into the MOD bumper. Ensure to orient the bezels with the Tall sides facing up/down, and the Narrow Notch facing towards the outside of the vehicle, ie: on the left two holes the narrow notch faces left, on the right holes it faces right, as indicated in **Figure 5**.

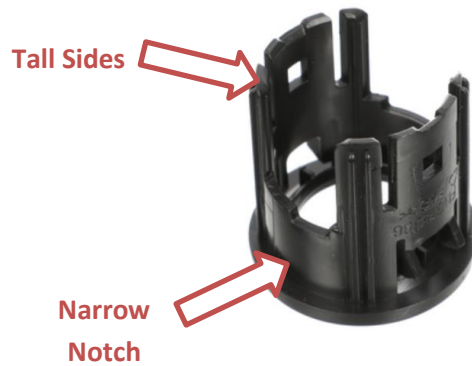

Figure 5

21. With the plug on the driver's side of the bumper, thread the rest of the sensor harness through the frame mounts across the bumper.
22. Install the sensors into the bezels with the connectors oriented to be facing towards the center of the bumper.
23. Tie strap the harness securely in place to the tie strap mounting locations provided.

WINCH MOUNT INSTALLATION [OPTIONAL]

VICE recommends using our Control Box Relocation kit when fitting your winch. Although it should be possible to fit a medium body winch with the controller on the winch, it will typically require some modification of the grill.

24. Remove the winches control box and relocate following the control box relocation instructions.
25. Install 2x M12x45 carriage bolts (*the longer M12 carriage bolts*) and push nut retainers into the fairlead mount holes of the winch plate. **Figure 6**

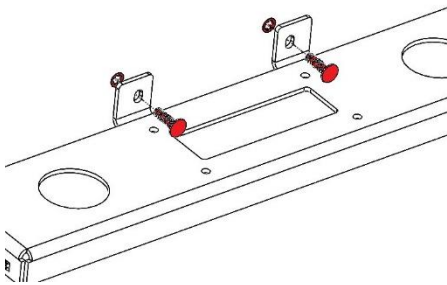

Figure 6

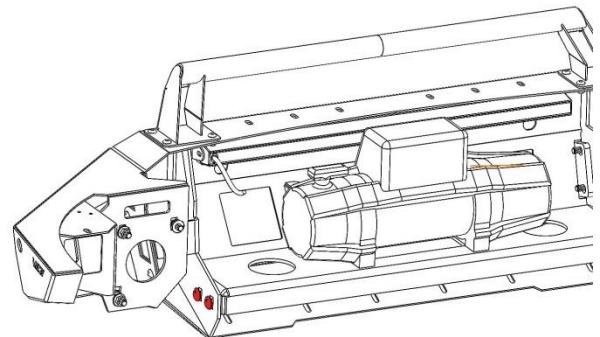

Figure 7

26. With the winch oriented to spool out the bottom, follow your winches manufacturers instructions to fix it to the VICE winch mounting plate.
27. Install the winch and winch plate assembly onto the bumper by inserting it onto the rear of the bumper and installing the fairlead. Loosely fit the 2x carriage bolts on either side, as there is an additional bracket which will install into these once the bumper is installed. See **Figure 7**.

INSTALLING THE BUMPER

28. With a partner, lift the bumper into place and loosely install the nuts onto the 6x frame mounting bolts.
29. Make fine adjustments to the bumpers level and positioning to ensure a clean and consistent gap at the top and fully torque the 6x frame mounting nuts.
30. You can now install the two braces (blue bracket in **Figure 8**) which tie the bumper primary mounts into the factory tow hook mount (red bolt in **Figure 8**). Use 2x 12mm carriage bolts on the bumper side retained with 12mm flange nuts, and 14mm flange bolt on the frame side.

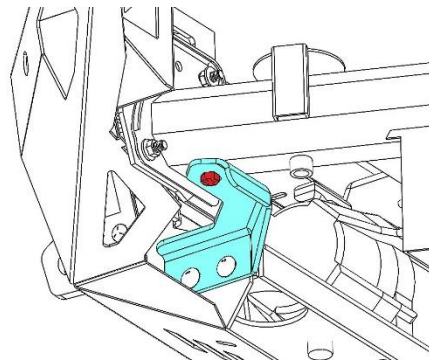

Figure 8

31. Once everything is adjusted to the body lines, torque all M12 carriage bolt fasteners to **65 ft-lbs** , and tighten the M14 Flange bolt from step 29 to **105 ft-lbs**.

INSTALLING THE SKIDPLATE(S) [OPTIONAL]

32. To prepare the skidplate, install the 6x U-Nuts onto the bumper side of the skidplate.
- Note the orientation of the U-Nuts; ensure that the raised threaded portion it toward the inside of the skidplate. Refer to **Figure 9** below.

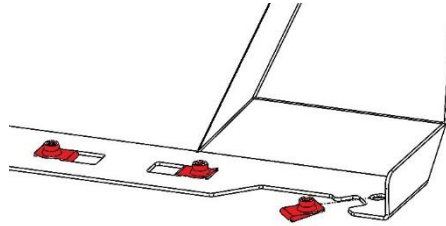
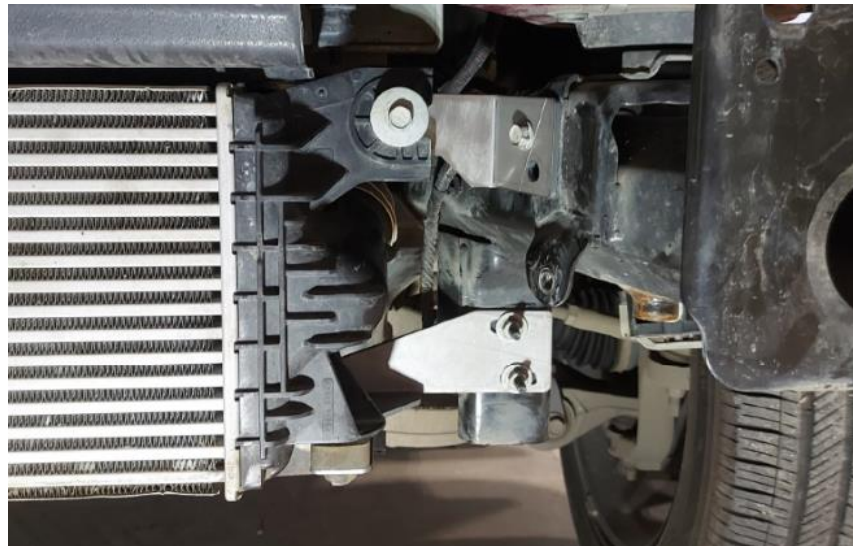

Figure 9

33. If your truck is equipped with the eco diesel motor:
- Remove the factory intercooler support brackets from either end of the intercooler
 - Install the 2x VICE intercooler relocation brackets using the factory hardware.



34. Remove the front two bolts from the factory differential skid plate
- If installing a VICE differential skid plate; remove all 4 bolts from this factory differential skid plate and replace with the VICE differential skid plate.
35. Install the skid plate by sliding it on top of the lower face of the bumper, and then doing up the two M10 x35mm Flanged bolts on the differential skid plate.
36. Install the 6x bolts fastening it to the lower edge of the bumper.
37. Tighten all M10 Flange bolts to **50 Ft-lbs** and stainless button heads to **19 ft-lbs**
38. After 100 km of driving, inspect and re-torque all bumper and winch fasteners.