

Cherry Blossom Gaming Headset

Thank you for purchasing this product.

Please read all the instructions carefully and keep this instruction manual for future reference. If you have any questions, please feel free to contact us at cs@mytrixtech.com

Getting to Know Your Headset

- A** Head Cushion
Padded headband for comfort.
- B** Ear Cushions
Breathable soft ear cushions for long gaming sessions.
- C** RGB LED Illumination
Connect the USB plug to a USB port to enable the RGB lighting on the earpads.
- D** Adjustable Boom Mic
Flexible microphone, with noise canceling for crisp clear voice.
- E** Nylon Cord
Strong woven cord for extra durability.



Headset In-Line Control

- A** Integrated In-Line Control
With volume & mute control.
- B** Volume Dial
Adjust the volume with the knob.
- C** Mute Switch
Slide up or down to mute or unmute

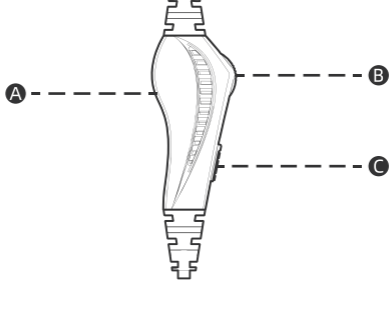

Package Includes

- 1x Cherry Blossom Gaming Headset.
- 1x Y-Cable (Adapter for PC) With Audio and Microphone Connectors.
- 1x User Manual.

RGB light Setup

To enable the LED light illumination on the headset, the USB plug will need to be connected to a powered USB port. USB ports can be found on a gaming console or computer.

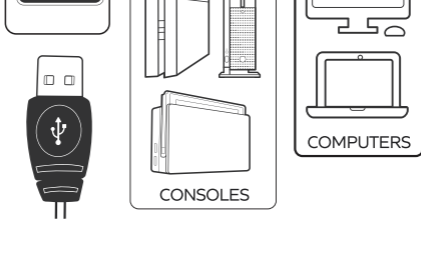

Setup for PC

1. If your computer has separate sound and mic input ports, plug in the headset's 3.5mm jack to the 2-in-1 splitter.
2. Connect the microphone jack from the splitter to the microphone jack located on your computer.
3. Connect the audio jack from the splitter to the audio jack located on your computer.

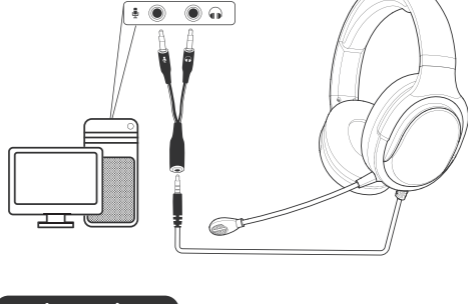

Other Devices

Connect the headset jack to the 3.5mm AUX port on your device.

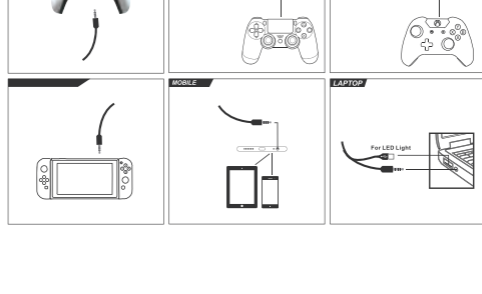

Specifications

Headphone:
 Speaker: 40mm
 Impedance: 32±2Ω
 Sensitivity: 120db±3db
 Frequency Range: 20 Hz-20 kHz
 THD:<= 1
 Rated Power: 15mW
 Max Power: 30mW

Microphone:
 Microphone Size: 6.0×5.0 mm
 Sensitivity: -46±3dB
 Directivity: Omni-Directional
 Impedance: <=2.2KΩ
 Frequency Range: 100hz-10khz

Troubleshooting & Customer Support

Troubleshooting:

NO LIGHTS	Make sure the USB cable is plugged into a power source either on your computer or console.
THE VOLUME ON THE HEADSET IS LOW	Make sure the volume on your device or console is turned up. You may need to go into your console's or device's settings to make this change.
MICROPHONE FEEDBACK NO AUDIO OR MUFFLED AUDIO	Unplug your headset and if it is connected to a controller turn the controller OFF & ON then reconnect your headset

Care & Maintenance

DO NOT expose the unit to liquid, moisture, or humidity to avoid damaging the product's internal circuitry.
 DO NOT use abrasive cleaning solvents to clean the unit.
 DO NOT expose the unit to extremely high or low temperatures as this will shorten the life of the electronic device, and/or distort certain plastic parts.
 DO NOT expose the unit to and/or use sharp objects on the headset.

DO NOT attempt to disassemble the unit.
 Please reach to us at cs@mytrixtech.com if you have encountered any issues.

Company Information

Company: Mytrix Technology LLC
 Customer Service: +1-978-496-8821
 Email: cs@mytrixtech.com
 Address: 13 Garabedian Dr. Unit C, Salem NH 03079
 Website: www.mytrixtech.com