



Known for Reliability Since 1921

The BIRO Model 44SSFH (Stainless Steel/Fixed Head) Power Meat Saw equipped with a 142" (3606.8 mm) Saw Blade is a heavy-duty, high-volume bandsaw that is well-suited for continuous intensive operation. The 3HP industrial motor, at 4000 feet per minute as standard blade speed, provides you with plenty of power and efficiency. BIRO's unique EZ-Flow meat carriage with 8 Stainless Steel Bearings helps reduce operator fatigue and increase productivity. The watertight magnetic electrical controller helps ensure safe, reliable operation. The 18" (457mm) diameter saw blade wheels with a 17-5/32" (435.8mm) horizontal cutting clearance and a full 17-1/8" (435mm) vertical cutting clearance (excluding Low-Profile, High Head, and some tabling) lets you cut larger product pieces than other saws. A broad range of designs, configurations, and options give you the flexibility to own a saw that fits your exact needs. The BIRO Model 44SSFH Series Power Meat Saws have superior durability and engineering features you've come to expect from BIRO, which means you'll get years of reliable use, low maintenance, and minimal overall cost of ownership.

44SSFH SERIES



Model 44SSFHTL
(Stainless Steel Fixed Head True Left)



Model 44SSFH
(Stainless Steel Fixed Head)



SPECIFICATIONS:
MODEL 44SSFH
(STAINLESS STEEL FIXED HEAD)
POWER CUTTER SERIES

Construction: Stainless steel.

Motors:

HP	TYPE	VOLTS	AMPS	CYCLE	PH	STATUS
3	DP	208-220/440	9.4-9.0/4.5	60	3	STD
3	DP	220/380-415	11.6/6.2-5.8	50	3	STD
5	MR	208-220/440	15.4-14.6/7.4	60	3	EC
5	TEFC	575	5.16	60	3	EC
5	MR	380-415	8.1-7.8	50	3	EC

DP = Drip Proof EC = Extra Cost MR = Moisture Resistant
 STD = Standard TEFC = Totally Enclosed Fan Cooled

Standard Features: Two saw blades, operation and parts manual, safety wall poster, end cut safety pusher plate (where applicable).

Switch: Watertight magnetic with thermal overload and under voltage protection.

Head and Door: Stainless steel fixed head, removable head door.

Blade Standard: Hard tooth, three teeth per inch (8.5 mm between teeth), 142" (3606.8 mm) long x 5/8" (16 mm) wide, .022" (.56 mm) thick (two supplied with each saw).

Blade Speed: Std. 4000 feet (1219 m) per minute approx. Higher blade speed available depending on product to be cut.

Blade Back-up Guides: Upper and lower blade backup guides, (both with long life carbide back-up inserts). Both assemblies removable for easy cleaning.

Blade Wheels: 18" (457 mm) cast iron, chrome nickel plating, upper wheel assembly lifts out.

Bearings: Heavy duty tapered roller bearings used in upper wheel and lower bearing housings.

Catch Pan: Poly, extra deep (rounded corners) pan sealed off from other parts of base, accessible through base hinged door.

Options (EC): Models 44SSFH (A-H) accept 142" (3606.8 mm) blade. (For reference: Low Profile - 135"/ High Head - 156" blades)

Cleaning Unit: Stainless steel body, long life carbide guide insert, stainless steel saw cleaners, removable as a unit for easy cleaning (assembly also adjustable as a unit).

Drive System: Non slip silent v-belt, tension adjustable.

Legs: Four stainless steel leg bolt levelers.

Meat Carriage: Stainless steel EZ-flow movement with eight stainless steel bearings.

Meat Gauge Plate: Stainless steel faced, adjustable from 1/16" (1.59 mm) to 6-1/2" (165 mm) locks in position, can be disengaged, entire assembly removable for cleaning.

Motor Compartment: Sealed off from meat contact areas, easily accessible through removable panel door.

Rear Platter: Stainless steel, held in place with two push pull hold down stainless steel rods (where applicable).

Safety End Cut Pusher Plate: Standard, removable pusher plate, storage hanger provided.

Certification: U.S.D.A., U.L., N.S.F., C.F.I.A.
 (C.S.A., STD., DP, 3HP-230-60-3)

Weight Standard Configuration: See drawing A
 Uncrated: 600 lbs. (272 kg.) approximate.
 Crated: 700 lbs (318 kg.) approximate.

Dims. Standard Configuration Crated: See drawing A
 L = 54"(137 cm), W = 45"(114 cm), H = 83"(211 cm).

Note: Weights and dims. of other designs will vary depending on the design and options selected.

See dimensional drawings, pages 3 & 4.	A	B	C	D	E	F	G	H
Power cord (12 Gauge) and plug- specify cord length- Required	EC	EC	EC	EC	EC	EC	EC	EC
Double movable saw guide bar, recommended on E & F	EC	EC	EC	EC	REC EC	REC EC	EC	EC
Stainless steel saw blade wheels - (IPOS)	EC	EC	EC	EC	EC	EC	EC	EC
Double flange cast saw blade wheels - (IPOS)	EC	EC	EC	EC	NC	NC	EC	EC
1" (25.4 mm) cast saw blade wheels - (IPOS)	EC	EC	EC	EC	NC	NC	EC	EC
Accepts 1" (25.4 mm) wide saw blade	EC	EC	EC	EC	EC	EC	EC	EC
Longer Stainless steel hex adjustable legs - 2" (51 mm) increments	EC	EC	EC	EC	EC	EC	EC	EC
Left hand feed (Left to Right) available for all listed designs	EC	EC	EC	EC	EC	EC	EC	EC
Narrow upper and table guides for .018 (.046 cm) thick saw blades - (IPOS)	EC	EC	NR	NR	REC EC	REC EC	NR	NR
Legend: STD = Standard EC = Extra Cost REC = Recommended NC = No Charge NR = Not Recommended								
IPOS = In Place of Standard; <i>All specifications contained herein are subject to change without notification.</i>								

SEE AVAILABLE POWER CUTTER OPTIONS PAGE 2.

A, Model 44SSFH-STD.

Standard right to left feed

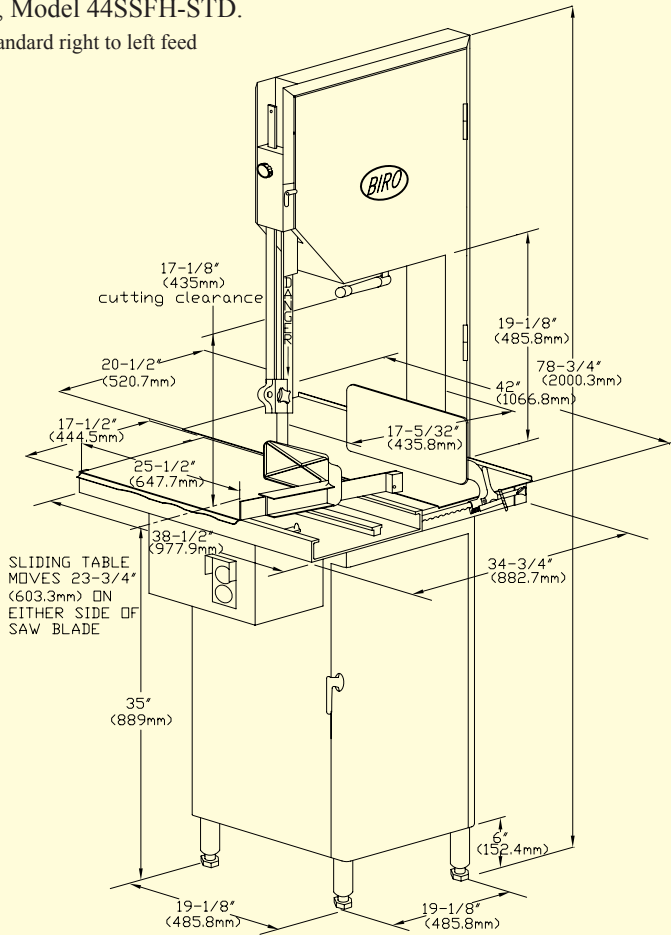

B, Model 44SSFH-T.L.

(True left to right feed)
Less meat gauge plate assembly.

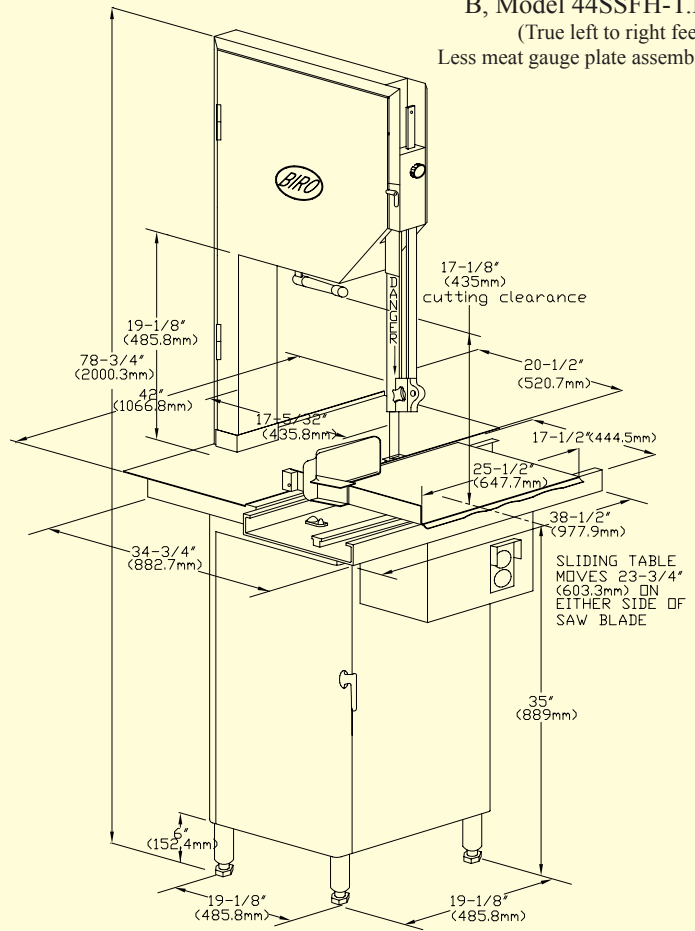

C, Model 44SSFH-F.F.T.

(Fixed Front Table)

Standard right to left feed.

Other front fixed table sizes available.

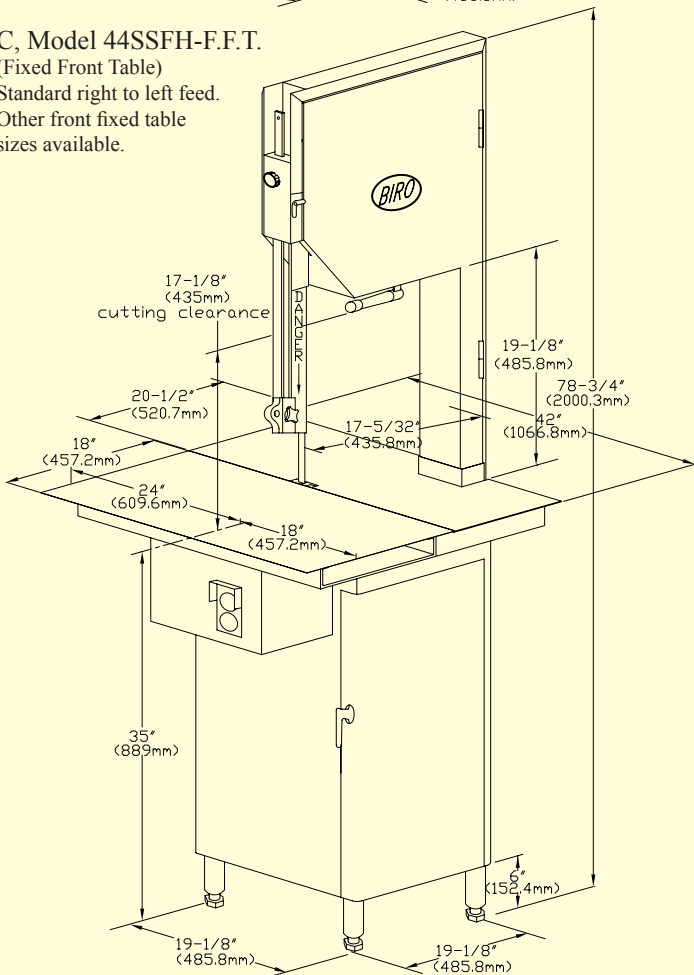

D, Model 44SSFH-H.D.F.F.T.

(Heavy Duty Fixed Front Table)

Standard right to left feed.

Other HD fixed table sizes available.

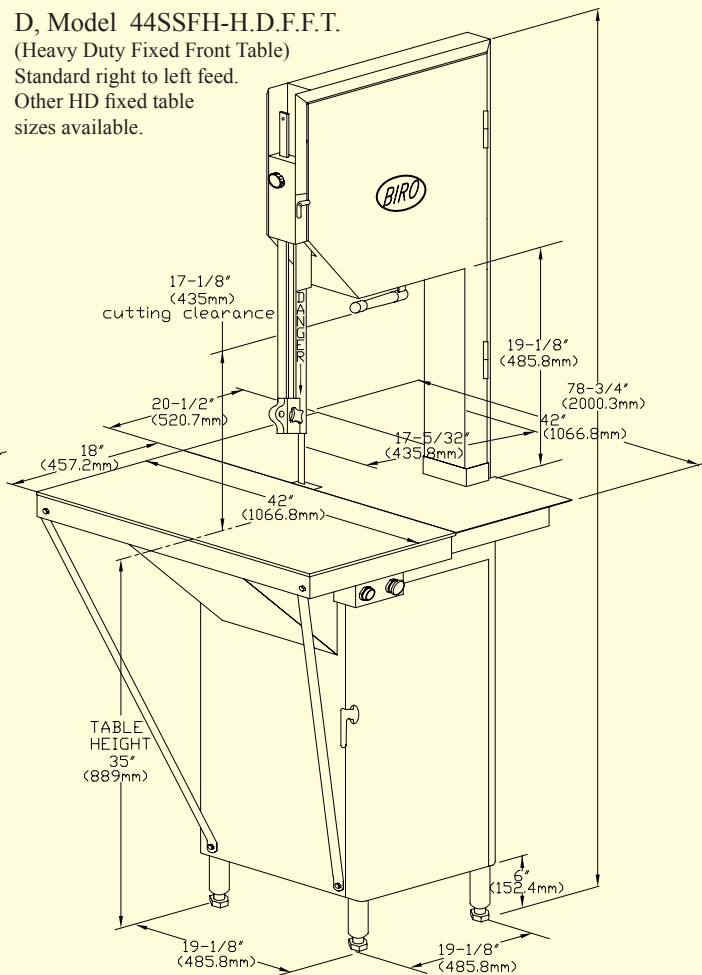

E, Model 44SSFH-P.C.G.P
 (Portion Control Gauge Plate)
 Standard right to left feed.

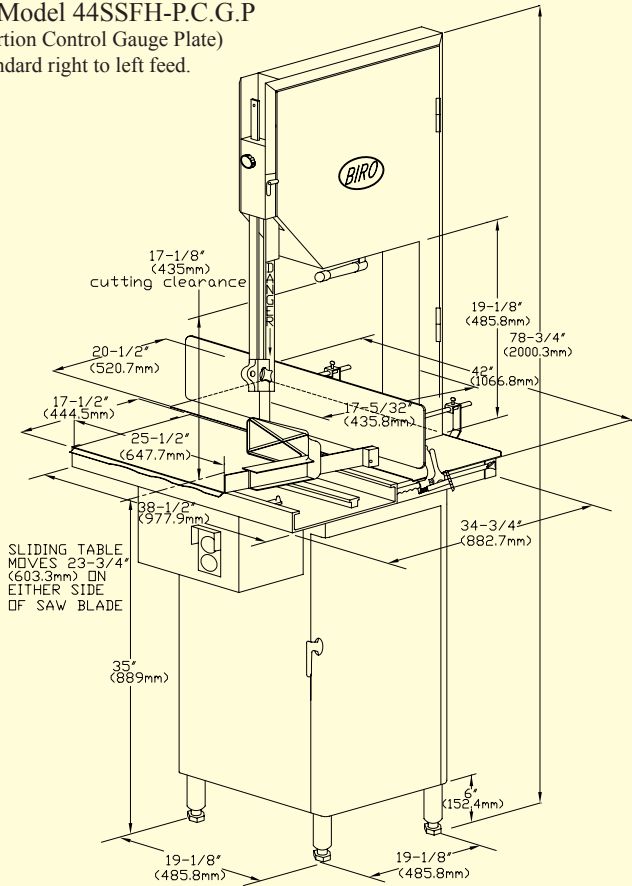

F, Model 44SSFH-P.G.F.
 (Precision Gauge Fence)
 Standard right to left feed.

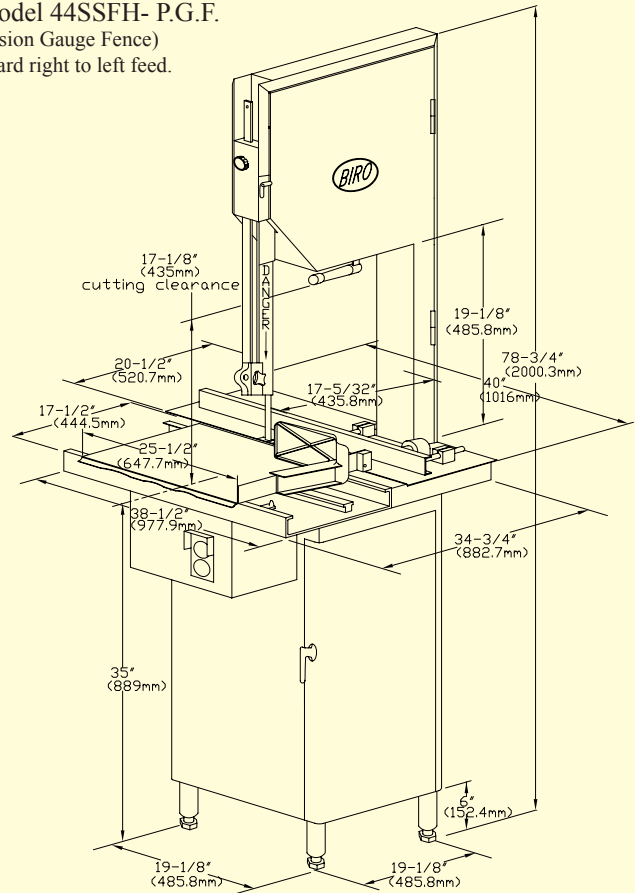

G, Model 44SSFH-D.R.T.
 (Double[inside/outside] Rolling Table)
 Standard right to left feed.
 Other rolling table sizes available.

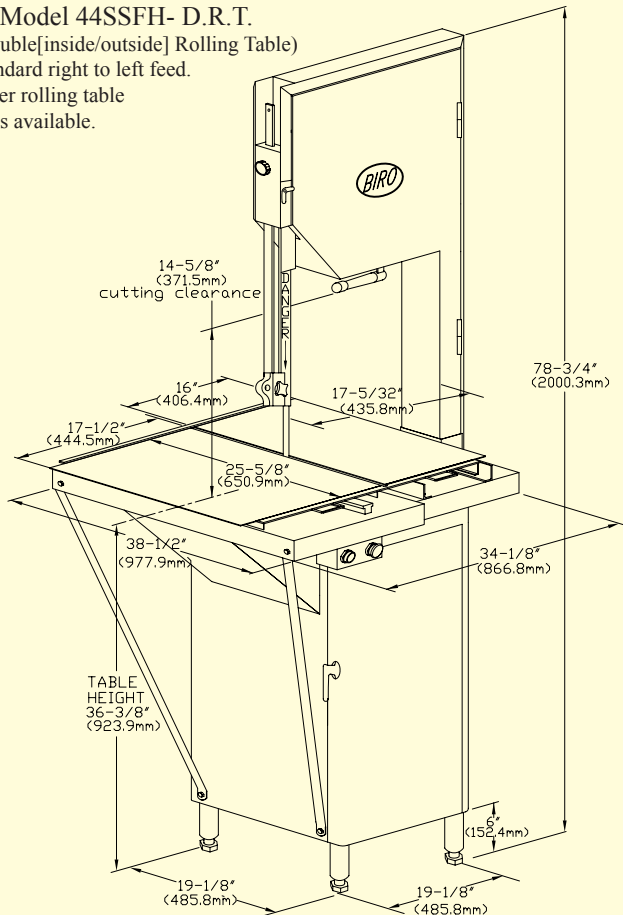

H, Model 44SSFH-R.C.T.
 (Double[inside/outside] Rolling Conveyor Tops)
 Standard right to left feed.
 Other rolling conveyor top sizes available.

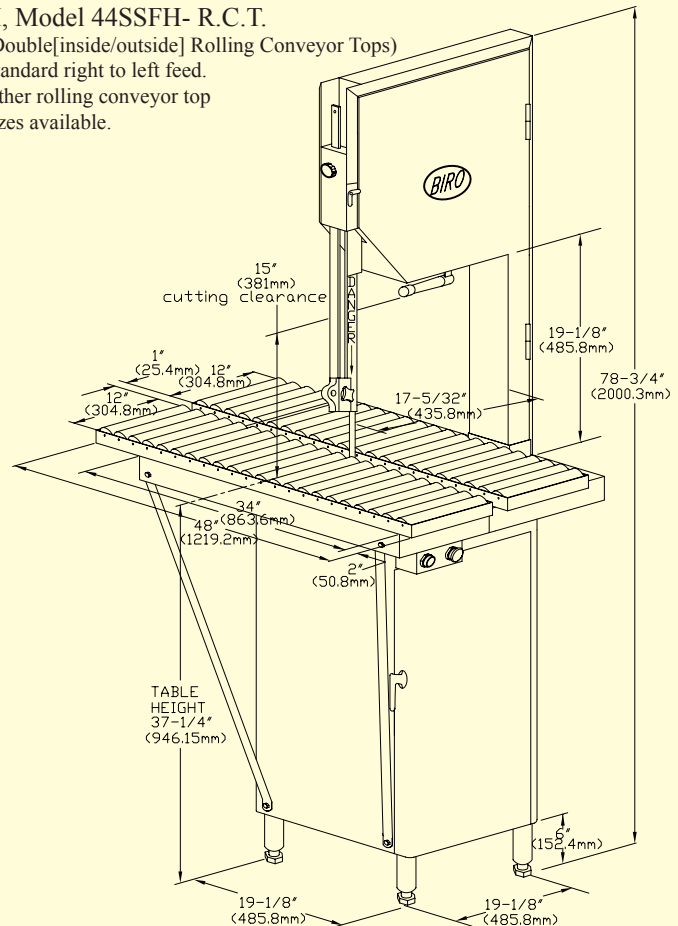

BIRO MANUFACTURING COMPANY
 1114 WEST MAIN STREET
 MARBLEHEAD, OH 43440-2099 U.S.A.

Phone: (419) 798-4451
 Fax: (419) 798-9106

www.birosaw.com
 sales@birosaw.com

ITEM NO.: LIT-44SSFH SERIES-369
 FORM NO.: 44SSFH-369-4-19-4 B

Service is available from locations worldwide