

POMPE A PISTONI ALTA PRESSIONE
HIGH PRESSURE PLUNGER PUMPS

•
IDROMECCANICA[®]
BERTOLINI



LIBRETTO ISTRUZIONI USO, MANUTENZIONE ORDINARIA
E NORME DI SICUREZZA
*OPERATING, SET-UP, ROUTINE MAINTENANCE AND SAFETY
INSTRUCTIONS*

HIGH PRESSURE PISTON PUMPS

You have decided to show your preference for the "**BERTOLINI**" brand and have bought a product which has been manufactured with the benefit of the most modern technology and the finest materials, designed through research to ensure its improved quality, duration and functionality.

We thank you for the trust shown in our products.

Please read this booklet with care and always keep it within easy reach. You will find it useful in resolving any problem you may have with regard to the characteristics and functionality of the product.

Thank you for having chosen "BERTOLINI"

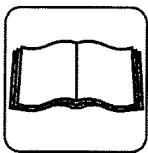

We at **Idromeccanica Bertolini** recommend that you read this Use and Maintenance Manual carefully before installing and using the pump. You should keep it within easy reach for any further reference. The Manual should be considered as an integral part of the pump itself.

Any person using the pump is expected to observe the relevant legislative provisions currently in force in the country where the pump is to be used. They are also required to follow the instructions set out in this Manual with care.

A- INTENDED USE

CAUTION

- The pump is only intended for pumping:
 - high-pressure water in washing machines (water cleaners);
 - water not for food use.
- The pump is not intended for distributing:
 - non – filtered water or water with dirt;
 - detergents, paints and chemical substances both in their pure state and in water solution;
 - sea water or high salt concentration water;
 - fuels and lubricants of any kind and type;
 - flammable fluids or liquefied gases;
 - food liquids;
 - water with temperature higher than 60°C or lower than 5°C;
- the pump must be never used to wash : persons, animals, electrical devices under voltage, delicate objects, the pump itself or the machine it is part of.
- The accessories (standard and optional) and the detergents used with the pump must be of the type authorised by the Producer .
- The pump is not suitable for the use in rooms that show particular conditions such as, for instance, corrosive or explosive atmospheres.
- For the use on vehicles, boats or aircraft, apply to the technical service of the Producer, because some added prescriptions can be necessary.

Any other use is improper.

The Producer cannot be hold liable for possible damage resulting from unintended or wrong uses.

B. OPERATION

PRELIMINARY ACTIVITIES

CAUTION

- **The pump cannot be commissioned if the machine that incorporates it does not conform to the safety requirements established by European Directives. This conformity is guaranteed by the presence of the CE marking and by the Declaration of Conformity of the Producer of the machine incorporating the pump.**
- Before starting up the machine, carefully read the indications of this manual and the instructions of the machine incorporating the pump. In particular, make sure that you have well understood the operation of the pump and of the machine incorporating the pump as far as the fluid sensing operations are concerned.
- Carry out the preliminary checks recommended by the producer of the machine incorporating the pump.
- Check that all delivery pipes are closed or connected to users in closed position (for instance water gun)
- Make sure that the pump moving parts are suitable protected and that they cannot be accessed by unauthorised personnel.
- Do not use the pump in case:
 - the pump has undergone strong hurts;
 - there are oil leaks;
 - there are visible water leaks;In these cases have the pump be checked by a **Skilled Engineer**.
- Have a **Specialized Engineer** make the scheduled checks as per the extraordinary maintenance.

WARNING

- In case of use at very low temperature, make sure that there is no ice inside the pump.
 - Carry out the scheduled checks of the routine maintenance with special reference to the ones relating to oil.
- a) Replace the oil plug without vent pos.2 by the oil plug with vent. This operation could have already been carried out by the Producer of the machine incorporating the pump.
 - b) With pump at a standstill, check that the oil level corresponds to the middle of the oil level light. The oil level can be also checked by unscrewing the plug with vent: the correct level must be included between the two notches on the rod. Remember that the oil level must be always checked with pump at a standstill and completely cooled down.
For possible filling, refer to the types of lubricants reported in paragraph 12 "Lubrication".
 - c) By referring to the use and maintenance manual of the machine incorporating the pump, check the cleaning of the suction filter.

This Use and Maintenance Booklet is made up of the following chapters:

1. General Safety Rules.
2. Product Description
3. Technical Features
 - Identification of components
 - Selection of pump and equipment design
4. Installation
 - Pump- motor coupling
 - Inlet circuit
5. High pressure circuit
6. Selection of the nozzle
7. Unloader valves- Pressure relief valves
 - 7.a. Technical features- Description
 - Unloader valves - Starting procedure
 - 7.b. Pressure adjusting
 - 7.c. Troubles and cures during the starting procedure
8. Pump- Starting procedure
9. Operation
 - 9.1 Operation with detergent
10. Shut down procedure, cleaning and standstill
11. Starting procedure after long time of no operation
12. Lubrication
13. Routine maintenance
14. Troubleshooting pump/unloader by-pass valve
15. Limited Warranty





















ROUTINE SERVICE AND REPAIR

- A. Pump
 - A.1. Check valves
 - A.2. Packings/ Seals
 - A.3. Ceramic plungers
- B. Unloader valve

Notes:

- a) This Manual is based on, and complies with, technical knowledge applicable as at the date of sale of the product and shall not be considered inadequate for the sole reason that it has been up-dated on the basis of new knowledge/experience.
IDROMECCANICA BERTOLINI S.p.A. has the right to up-date its products and related manuals without being thereby obliged to up-date previous products and manuals, save in cases deriving exclusively from safety considerations.
- b) You may consult our Customer Service in relation to any query or need arising when using or servicing the product and to obtain assistance in choosing accessories to use with it.
- c) No part of this Manual may be reproduced without the written permission of **IDROMECCANICA BERTOLINI S.p.A.**

1- GENERAL SAFETY RULES

-  The high energy on the pressure jet is a source of serious dangers.
 -  The pump must be used only by skilled personnel.
 -  It is strongly recommended to fit mechanically pre-fastened high pressure hoses. They must be homologated for the Max. admissible pressure in the system, and they must carry over the stamping of the overpressure and the max. admissible temperature, besides the name of the producer and date of production.
 -  Before starting check always your machine. Particularly check the integrity of plumbing, high pressure fittings, the gun trigger that should work in a soft way, without releases and immediately return to its position, when off.
 -  Do not install defective high pressure hose and do not try to repair it, rather replace it by an original spare part.
 -  Keep children and animals away from the pump.
 -  Make sure that your system is installed on a strong and safe base.
 -  Always wear eye protection and protective clothing when operating.
 -  Hold always the gun with both hands. Do not open the pressure jet without holding firmly the trigger gun.
 -  Do not turn the jet against persons, animals and fragile objects.
 -  Do not turn the jet against cables or electric equipment, sockets or nearby.
 -  Do not place yourself in front of the pressure jet.
 -  To clean the delicate surfaces use exclusively fan-shaped jets and keep nozzle 75 cm away.
 -  Do not operate gasoline engine in an enclosed area. Be sure that the area is well ventilated.
- THE EXHALATION OF THE EXHAUST GAS COULD BE MORTAL!
-  Provide adequate protection in guarding around the moving parts.
 -  Do not use the equipment to clean surfaces that contain asbestos.
 -  Follow strictly the current regulations of draining of the substances taken down from the surfaces where the pressure jet is used.
 -  Carry out the preliminary checks recommended by the producer of the machine that incorporates the pump.
 -  High pressure jet is dangerous: do not turn the jet against yourself or others.
 -  *Pump must not be used by children or not trained personnel.*

Idromeccanica Bertolini S.p.A. declines any civil or criminal liability for damage or accidents to persons or property as may arise from the failure to observe even only one of the above safety rules

2- PRODUCT DESCRIPTION

Bertolini high pressure piston pumps are designed to pump clean water, and can be used with a temperature up to 60°C.

Do not pump acids or abrasive fluids; consult factory for additional information on questionable fluids.

Pump operation must be within the specifications indicated on the label (fig. 1); do not remove label, otherwise the warranty will be void.

3- TECHNICAL FEATURES

Upon receipt of the pump, check over the label which is similar to the one illustrated below.

The following data are indicated on the label:

1. Max. admissible pressure in bar
2. Max. admissible pressure in P.S.I.
3. Pump model
4. Max. flow rate in l/min
5. Max. flow rate in U.S.G.P.M.
6. Serial number
7. Max HP required at the max. pressure
8. Max. R.P.M.

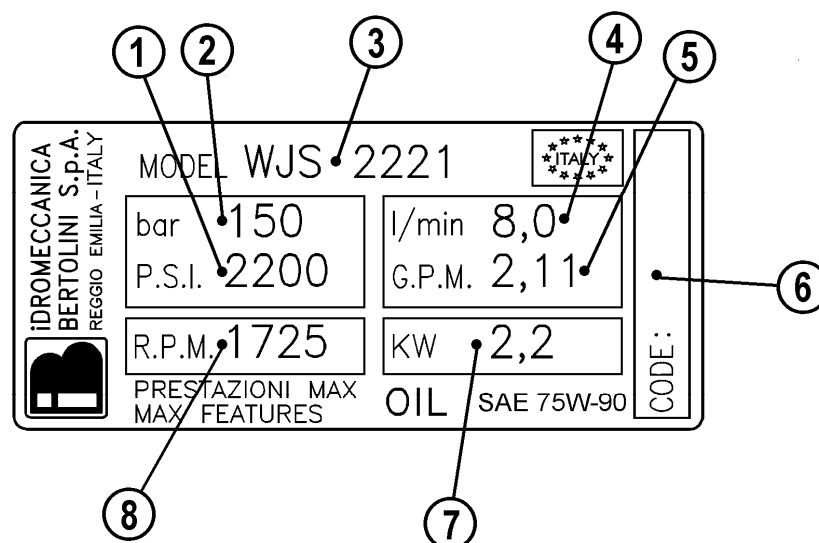

Fig.1

In any case the figures of the pump model enable to identify maximum flow rate and pressure (even if label shows just the pump figures).

With the two first figures you can identify the maximum flow rate in PSI (ex. 40= 4000 PSI = 280Bar).

With the two last figures you can identify the maximum pressure in GPM (ex. 37=3.7 GPM= 14.1l/min)

3.1. IDENTIFICATION OF COMPONENTS

1. Identifying label
2. Oil sight glass with dipstick
3. Pump shaft
4. Discharge
5. Inlet
6. Suction valve cap
7. Pump head or pump body
8. Discharge valve cap

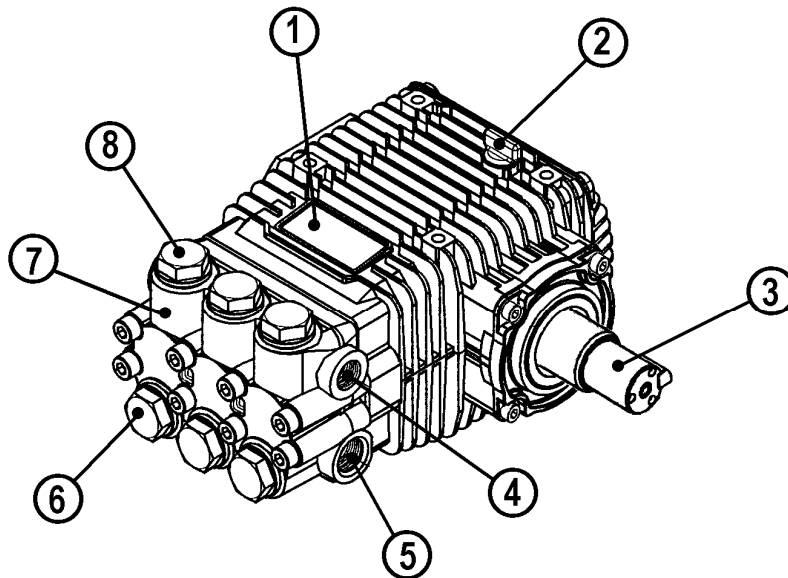

3.2. SELECTION OF PUMP AND EQUIPMENT DESIGN

With regard to safety, all pumps meet the **UNI EN 809** standards and they are intended for mounting directly or by transmission, with an electric motor, petrol engine or hydraulic motor.



When wiring an electrically driven pump follow all electrical and safety EN 60204.1 standards.



The equipment manufacturer should take care of the proper selection and correct size of the operation system to prevent possibly bodily injury. In particular provide adequate protection in guarding around the moving parts, according to the provisions in force.

4- INSTALLATION



Correct installation is the determining factor for good functioning and long life of the pump.

90% of failures and of the misfunctions are consequence of:

- Wrong coupling between pump and motor/engine.
- Wrong inlet circuit.
- Poor quality or not correct adjusting of the unloader valve or pressure relief valve.

Idromeccanica Bertolini S.p.A. declines any liability as may arise from the failure to observe even only one of the following instructions:

4.1. PUMP-MOTOR COUPLING

- In order to obtain correct lubrication of all moving parts the pump must work with the axis of the pistons in horizontal position.
- The pump-motor/engine assembly must be properly installed on a strong base plate.
- When wiring an electrically driven pump follow all electrical and safety EN 60204.1 standards to prevent accidents.
- All wiring must be done by qualified electricians.
 - In case of direct coupling to motor/engine be sure that:
 - the motor/engine shaft is perfectly aligned and centered as to the pump shaft
 - the key is of correct length
 - the pump flange leans against the motor flange before tightening bolts
 - In case of gearbox drive follow the same above recommendations as to the coupling between flanges and between motor/engine shaft- primary shaft and driven shaft-pump shaft
 - In case of pulleys drive check:
 - there is no slack between shafts and pulleys
 - that pulleys are parallel and aligned
 - that belts are correctly stretched. An excessive belts tension will cause premature wear of the bearings.

4.2. INLET CIRCUIT

Inlet can be either in pressure (for all models of pumps) or in suction (only for a few models).

- In any case we recommend to fit an inlet strainer rated at least 2 times the rated flow of the pump.
- In case of inlet in pressure from water system be sure that the flow is suited to that one of the pump. The inlet pressure cannot exceed 5 bar. (72 P.S.I.)
- In case of inlet from a tank, in pressure or in suction, respect the following instructions and what indicated in fig. 3.
 - The tank must be rated at least 4 times the rated flow of the pump (L/min)
 - The inlet pipings must suck close to the tank bottom, water head of at least 200 mm to prevent the formation of siphons, in case the tank is at same level or higher than the pump.
 - The sucking area must be protected from turbulence created by the inlet pipe of the tank, and from the eventual return pipings by proper bulkheads closed on the bottom.
 - The tank must be fitted with a device capable to stop the pump in case of insufficient level of water.
 - The suction hoses and the fittings must have the same sizes shown in the chart. If length exceeds 10 mt. it is necessary to increase the diameters proportionally to the estimated loss of pressure.

Suction hole of the pump	Min. internal dia. of suction hose
3/8" bsp	mm. 9 / 3/8"
1/2" bsp	mm. 14 / 9/16"
3/4" bsp	mm. 18 / 3/4"

-Use only rigid or flexible anti-crushing hoses.

-In case of negative inlet, plumbing to the pump must be airtight, so that pump will not suck air.

-In order to avoid risk of cavitation it is necessary to limit to 1.5 mt. (0,5 mt. for pumps running at fast RPM) the negative pressure of the pump.

-Inlet plumbing must be as rectilinear as possible, keep 90° elbows, bends and valves to a minimum.

-When a device for the detergent suction is installed on the pump inlet do not forget that air is often sucked just from that area.

PUMP/ UNLOADER VALVE - INSTALLATION DIAGRAM

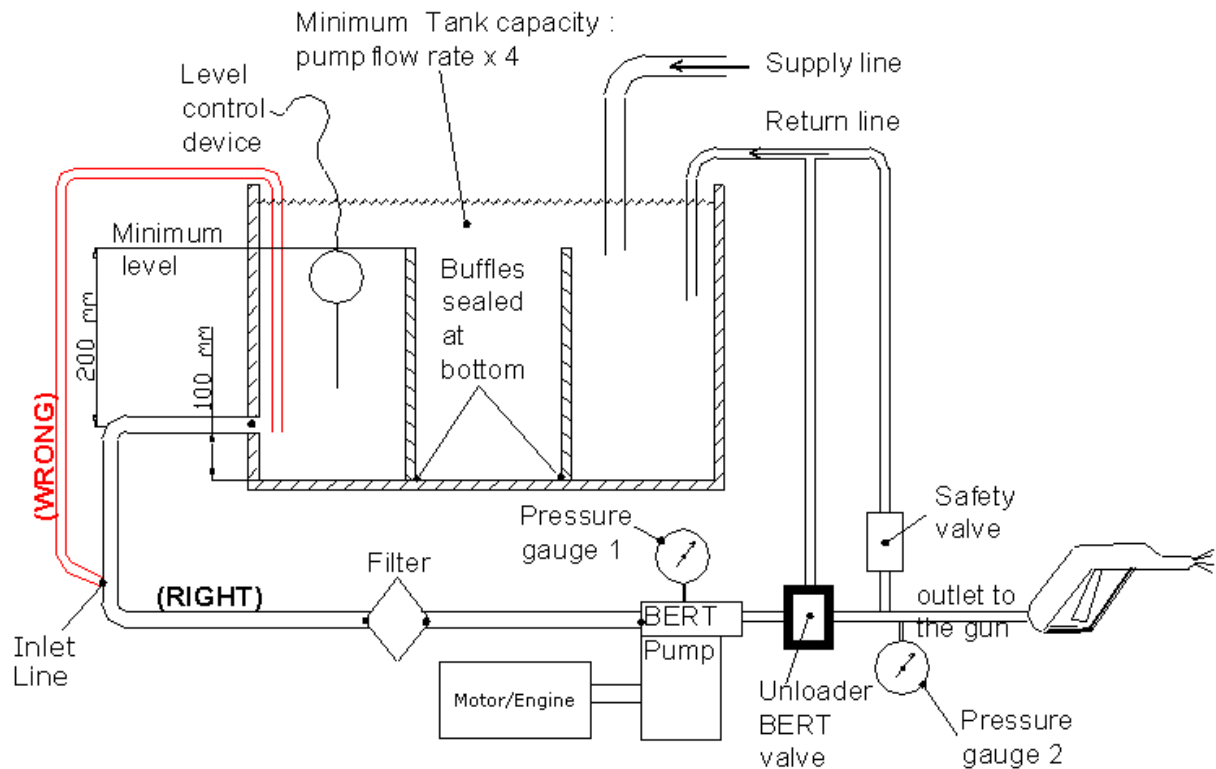

Fig. 3

5- HIGH PRESSURE CIRCUIT

The high pressure circuit must be built-up with adequate components that have minimum performance (pressure and flow), at least 30% more than those reached by the pump.

It is recommended to install a safety relief device set at a pressure of 20-25% more than the setting value of the unloader valve.

In particular, the flexible hoses must have the fittings mechanically seamed directly by the manufacturer and they must carry over the stamping of the name of the manufacturer, the manufacturing date, the rated pressure and the max. admissible temperature.

6- SELECTION OF THE NOZZLE

Particular attention is needed for the selection of the nozzle, which flow must not exceed 90÷95% of the pump flow.

Check in the chart supplied by the nozzle's manufacturer correct flow and pressure.

If the nozzle is too small it will force the unloader valve to by-pass continuously an excessive amount of water, causing premature wearing of its components; furthermore for the same power absorbed from the pump the water flow to the nozzle will be restricted and your system will reduce its performance.

If the nozzle is too large, the system will not reach the required operating pressure.

NOZZLES CHART

NOZZLE		Nozzle selection																												
MEG	hole	hole	Flow rate in GPM at the indicated pressures																											
	Ø mm	Ø INCH	20	30	40	50	60	70	80	90	100	110	120	130	140	150	160	180	200	220	250	280	310	340						
			bar	bar	bar	bar	bar	bar	bar	bar	bar	bar	bar	bar	bar	bar	bar	bar	bar	bar	bar	bar	bar	bar	bar	bar	bar	bar		

			290	435	580	725	870	1015	1160	1305	1450	1595	1740	1885	2030	2175	2320	2610	2900	3190	3625	4060	4560	5000
			psi	psi	psi	psi	psi	psi	psi	psi	psi	psi	psi	psi	psi	psi	psi	psi	psi	psi	psi	psi	psi	psi
..02	0,99	0,039	0,53	0,66	0,74	0,84	0,92	0,98	1,06	1,11	1,19	1,24	1,29	1,35	1,40	1,45	1,50	1,58	1,69	1,77	2,01	2,24	2,48	2,72
..03	1,09	0,043	0,82	0,98	1,14	1,27	1,40	1,50	1,61	1,66	1,80	1,90	1,95	2,03	2,11	2,19	2,30	2,43	2,53	2,64	3,01	3,38	3,75	4,12
..035	1,15	0,045	0,95	1,16	1,35	1,48	1,64	1,77	1,93	2,03	2,14	2,22	2,32	2,43	2,53	2,61	2,75	2,88	3,01	3,17	3,43	3,75	4,07	4,38
..04	1,19	0,047	1,11	1,37	1,56	1,74	1,93	2,06	2,22	2,35	2,48	2,59	2,72	2,82	2,93	3,04	3,14	3,27	3,48	3,72	3,91	4,09	4,28	4,46
..045	1,27	0,050	1,19	1,45	1,69	1,87	2,06	2,22	2,38	2,53	2,69	2,80	2,96	3,06	3,12	3,30	3,33	3,48	3,80	3,96	4,17	4,38	4,59	4,80
..05	1,35	0,053	1,32	1,64	1,87	2,11	2,30	2,48	2,64	2,82	2,98	3,09	3,19	3,41	3,54	3,64	3,78	3,99	4,20	4,46	4,73	4,99	5,25	5,52
..055	1,4	0,055	1,48	1,80	2,06	2,30	2,53	2,72	2,93	3,12	3,27	3,43	3,56	3,72	3,88	4,01	4,14	4,33	4,62	4,91	5,17	5,44	5,70	5,97
..06	1,47	0,058	1,58	1,95	2,27	2,53	2,75	2,98	3,19	3,38	3,59	3,75	3,93	4,09	4,22	4,38	4,54	4,75	5,07	5,39	5,68	5,97	6,26	6,55
..065	1,52	0,060	1,74	2,11	2,46	2,75	2,98	3,25	3,48	3,70	3,88	4,09	4,25	4,41	4,59	4,75	4,91	5,12	5,46	5,81	6,12	6,44	6,76	7,08
..07	1,6	0,063	1,87	2,27	2,64	2,96	3,22	3,48	3,72	3,96	4,17	4,38	4,57	4,75	4,94	5,10	5,31	5,62	5,89	6,26	6,60	6,94	7,29	7,63
..075	1,65	0,065	2,01	2,46	2,82	3,17	3,46	3,75	4,01	4,25	4,46	4,67	4,88	5,07	5,28	5,46	5,65	5,97	6,28	6,68	7,05	7,42	7,79	8,16
..08	1,7	0,067	2,11	2,59	2,98	3,35	3,70	2,93	4,25	4,51	4,75	4,99	5,20	5,41	5,62	5,81	6,02	6,28	6,71	7,13	7,52	7,92	8,32	8,71
..085	1,75	0,069	2,24	2,75	3,19	3,56	3,91	4,22	4,51	4,78	5,04	5,28	5,52	5,73	5,94	6,18	6,34	6,73	7,13	7,44	7,92	8,40	8,87	9,35
..09	1,8	0,071	2,40	2,93	3,38	3,78	4,14	4,49	4,75	5,07	5,33	5,60	5,83	6,07	6,31	6,52	6,73	7,05	7,52	8,00	8,42	8,84	9,27	9,69
..095	1,85	0,073	2,56	3,14	3,54	4,07	4,44	4,78	5,12	5,28	5,73	5,99	6,28	6,52	6,84	6,86	7,10	7,52	7,92	8,32	8,76	9,21	9,66	10,11
..10	1,9	0,075	2,64	3,25	3,75	4,22	4,59	4,99	5,31	5,65	5,94	6,23	6,49	6,76	7,02	7,26	7,52	7,87	8,40	8,90	9,40	9,90	10,40	10,90
..11	1,98	0,078	2,93	3,59	4,14	4,65	5,10	5,49	5,86	6,23	6,57	6,73	7,05	7,31	7,60	7,89	8,13	8,61	9,08	9,50	10,14	10,77	11,40	12,04
..12	2,08	0,082	3,19	3,91	4,54	5,07	5,54	5,99	6,42	6,81	7,15	7,42	7,76	8,05	8,40	8,69	8,98	9,50	10,03	10,51	11,19	11,88	12,57	13,25
..125	2,13	0,084	3,35	4,12	4,75	5,31	5,81	6,28	6,73	7,13	7,52	7,79	8,13	8,47	8,79	9,11	9,40	9,98	10,51	11,04	11,75	12,46	13,17	13,89
..13	2,16	0,085	3,48	4,25	4,91	5,49	6,02	6,49	6,94	7,37	7,76	8,13	8,50	8,84	9,19	9,50	9,82	10,27	11,22	11,62	12,30	12,99	13,68	14,36
..14	2,26	0,089	3,75	4,59	5,28	5,91	6,47	7,00	7,50	7,95	8,37	8,76	9,16	9,53	9,90	10,24	10,59	11,22	11,83	12,41	13,23	14,04	14,86	15,68
..15	2,34	0,092	3,99	4,88	5,62	6,31	6,89	7,47	7,97	8,47	8,92	9,40	9,82	10,22	10,61	10,98	11,35	12,04	12,67	13,31	14,18	15,05	15,92	16,79
..16	2,41	0,095	4,28	5,23	6,05	6,76	7,39	8,00	8,55	9,08	9,56	9,98	10,43	10,85	11,27	11,67	12,04	12,78	13,46	14,12	15,05	15,97	16,90	17,82
..18	2,54	0,100	4,80	5,89	6,78	7,60	8,32	8,98	9,61	10,19	10,74	10,61	11,59	12,06	12,51	12,94	13,38	14,18	14,94	15,68	16,71	17,74	18,77	19,80
..20	2,69	0,106	5,31	6,52	7,52	8,42	9,21	9,98	10,64	11,27	11,91	12,49	12,99	13,52	14,04	14,52	15,00	15,92	16,76	17,58	18,74	19,38	20,54	21,70
..25	2,99	0,118	6,65	8,16	9,42	10,51	11,51	12,43	13,31	14,10	14,89	15,60	16,32	16,98	17,69	18,24	18,82	19,83	21,07	22,18	23,58	24,97	26,37	27,77

HOW TO READ CHART

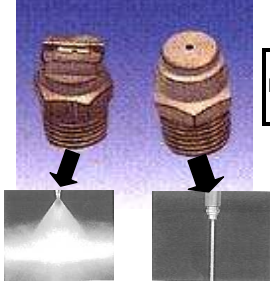
	<p>Nozzles flow rate must not exceed 90,95% of pump flow rate.</p>	<p style="text-align: center;"><i>Flow area for WJ pumps</i></p> <p>Ex. of nozzle selection WJH : 140bar-11,4 l/min</p> <p><i>(calculate 93% of the flow value) ≈ 11,1</i></p>
---	--	---

7. UNLOADER VALVES/ PRESSURE RELIEF VALVES

7.a TECHNICAL FEATURES. DESCRIPTION



For your safety and for safety of your system it is strictly recommended that the high pressure circuit is protected against overloads from a pressure relief valve correctly set.



Choose always the unloader valve according to the performance of your pump (max flow-max pressure).

Model	Pressure range (BAR)	Max. Pressure (BAR)	Max. Flow (L/min)
APR-I 20	From 0 up to 140	140	15
APR-I 25	From 140 up to 175	175	15
APR-I 30	From 175 up to 210	210	21
APR-I 30 N			

Model	Pressure range (bar)	Max. Pressure (BAR)	Max. Flow (L/min)
UNIFIT 20	from 0 up to 140	140	30
UNIFIT 30	from 140 up to 210	210	30
VD 140	from 140 up to 210	140	30
VD 200	from 0 up to 140	210	30
VD 200 N			
VD 280 N	from 210 up to 275	275	30
VD 25/350	from 275 up to 350	350	25

APR/APR-I MODEL- Identification diagram

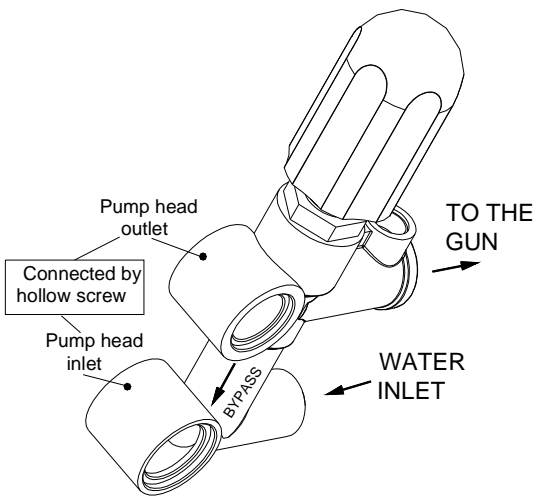

These valves are connected to the head by 2 hollow bolts.
The recycle of the by-pass water is inside the valve and returns directly to the head.

UNIFIT & VD MODELS – Identification diagram

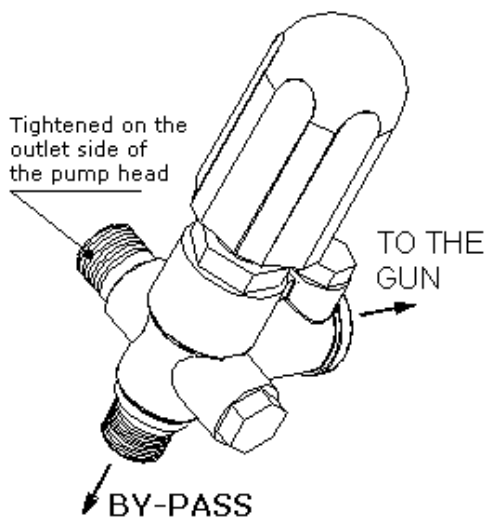

These valves are tightened on the high pressure side of the pump head.
The by-pass water must be connected to the inlet circuit or return to the tank of the pump.



Setting of unloader valve must be done only by skilled personnel. All instructions indicated by manufacturer must be observed.

Bertolini valves have been designed to ensure the best efficiency of the system protection and long life of the pump.

When the gun is open they work as pressure relief valves, they return to by-pass the amount of water in excess, at the setting pressure of the valve.

If, for example, while working with a system set at 140 bar, the nozzle is clogged, the valve is partially opening and is returning to by-pass the amount of water that cannot go through the nozzle, so that the pressure is not overcoming the setting value of the valve.

Instead, when the gun is shut off, the valve is completely opening and is returning to by-pass the whole amount of water.

Bertolini valves are conceived in a way that, in these conditions, only the part of the circuit between the valve and the gun remains on pressure, while the water recycling is done at a very low pressure (less than 5 bar -72 P.S.I.).

In this way the pump is turning on with a minimal absorption of power and the recycling water is warming up very slowly, providing extended life of the pump and of the seals.

The maximum working time in by-pass must never exceed 5 minutes. Otherwise seals will wear quickly.



All Bertolini valves are tested and adjusted in the factory at the max. pressure indicated in the chart.



When necessary, the system's manufacturer should **REDUCE** the max. setting pressure of the valve in order to conform to the max. operating pressure of the pump.



DO NOT BOOST THE SETTING PRESSURE



THE REDUCTION OF THE MAX. SETTING PRESSURE VALUE IS ONLY TO BE CARRIED OUT BY THE SYSTEM'S MANUFACTURER. THE FOLLOWING INSTRUCTIONS MUST BE RESPECTED.

UNLOADER VALVES - STARTING PROCEDURE

7.b PRESSURE ADJUSTING

1. Check on the pump label the data and the correct setting pressure.
2. Make certain that nozzle mounted on the lance has the correct size (see nozzles chart) and is not clogged.
3. Connect the high pressure hose to the pump and check the connection between hose and gun.
4. Connect pump to the inlet circuit.
5. If you have a double lance carry the knob to low pressure position.

6. Extract the adjustable knob (1) and loose with a 3 mm Allen wrench the adjustable dowel (2) until to discharge completely the spring

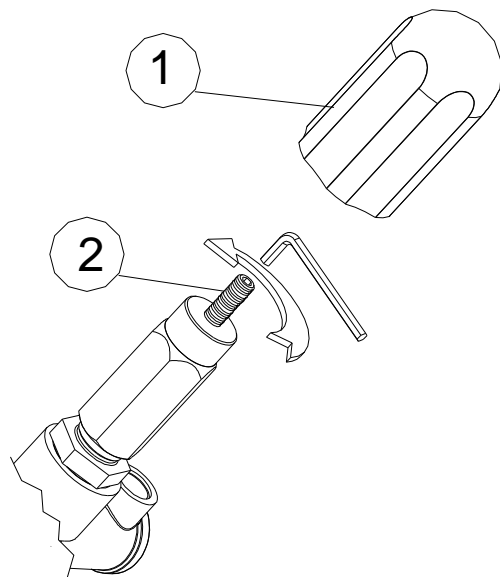

7. Screw by hand the hexagonal part (3) up to the end of stroke, into hexagon (4). Apply one drop of Loctite (green) to the dowel thread.

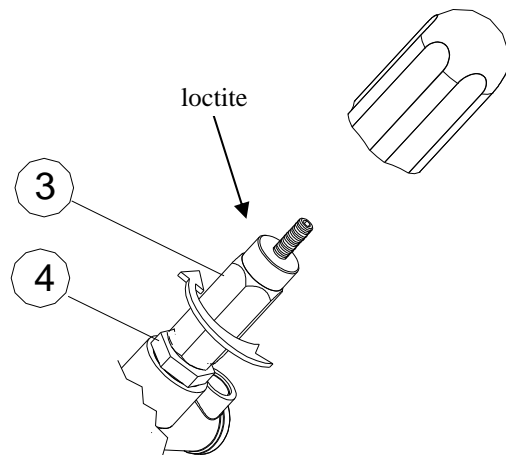

8. Operate the trigger checking its correct functioning.
9. Hold the gun trigger pressed and start the motor/engine.
10. Turn the pump until the water is running out from the nozzle with a continuous and smooth jet.
11. If you have a double lance carry the knob to high pressure position.

12. Hold the gun trigger and turn clockwise the adjustable dowel (2). Be sure that the needle of the pressure gauge goes up regularly while you screw the dowel. The two pressure gauges will show nearly the same pressure (slightly lower on the second gauge compared to the first one).

13. When you have reached nearly 50% of the max. required pressure release the gun trigger and make certain that:

-the pressure of the pressure gauge 1 comes down below 5 bar. (72 P.S.I.)

-the pressure of the pressure gauge 2 is not more than 10-15% of the pressure indicated with the open gun.

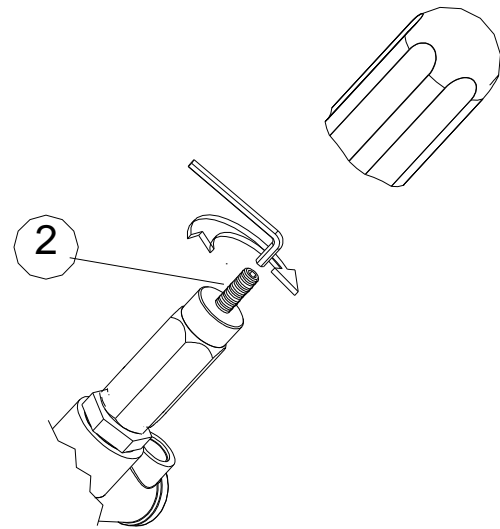

14. Operate twice or three times the gun trigger and check, with gun off, that the pressure of the pressure gauge 2 is steady.

15. Go on as indicated in the above step 12 until to reach the required pressure and repeat all checks of steps 13 and 14.

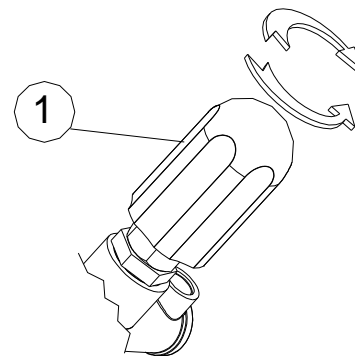

16. The dowel is locked by Loctite (step 7). Once that you have re-positioned the adjustable knob (1), you can adjust pressure safely, simply by unscrewing or screwing it, and you will never exceed the setting pressure.



AFTER STOPPING THE PUMP POINT LANCE AT SAFETY DIRECTION AND PRESS THE GUN TRIGGER IN ORDER TO DISCHARGE THE RESIDUAL PRESSURE FROM THE HIGH PRESSURE HOSE. FAILURE TO OBSERVE THIS SAFETY RULE COULD RESULT IN PERSONAL INJURY OR DAMAGE TO THE PUMP.

7.c TROUBLES AND CURES DURING THE STARTING PROCEDURE

Ref.	Problem	Solution	Probable consequences
Point 8	The gun trigger is crawling during the operation or does not return to its position quickly.	Replace the gun by a new one.	Malfunction of the by-pass valve with possible damages on the pump and the system.
Points 12-15	In spite of your attempts to screw the dowel 3, pressure is not going up.	Do not release the gun trigger before decreasing pressure. -Check the safety valve (if installed) that may not work correctly or at too low pressure. -Check nozzle (if too large or worn). -Check poppet of the pressure regulator (maintenance 1)	Risk of overload on the pump as soon as you shut off gun.
Point 13	Pressure gauge 1 shows high pressure when shutting off gun.	-check the trigger gun: once that gun is shut off it must return quickly to its position. -check the poppet of the gun. -check the piston of the pressure regulator (maintenance 2)	By-pass does not work correctly (overloads risk). Water is recycled at too high pressure and may cause overheating of pump.
	Pressure on pressure gauge 2 goes up over the prescribed values.	-with gun on, unloose the dowel until pressure is going down and try to shut off gun. -If problem continues check pressure regulator (maintenance 2).	Overpressure of the by-pass is too high and may damage pump or system.
Point 14	With pump in by-pass, gun shut off, pressure on the pressure gauge 2 tends to decrease.	Check water leaks (if any) from: -high pressure hose connectors -gun poppet -safety valve (if installed). Check the non-return valve of the pressure regulator (maintenance 3).	Continuous pressure peaks on the circuit, even when gun is shut off. Anomalous stress on the pressure circuit

8. PUMP STARTING PROCEDURE

Before starting pump check to make sure that:

- The suction hose is not damaged or bent;
- The suction strainer is clean;
- The nozzle is unclogged. It must be of proper size and replaced when worn.
- Prime the pump, gun on, to allow air to escape; a quick priming of the pump prevents malfunctions of the pumping elements (packings, pistons);
- The water flow is open or the tube is plunged in the supplying container.
- Do not run the pump dry, it may cause irreparable damages to the packings and sealing components.

9. OPERATION

Carry out the preliminary controls mentioned in the previous paragraph, therefore, after setting at zero the pressure (anticlockwise rotation of the by-pass valve knob), open the lance and start the pump.

Wait for a few seconds to allow pump priming and the hydraulic functioning, after adjust pressure on the valve at the required value (Clockwise rotation of the by-pass valve knob).

After, set out pressure at the required value, if the machine manufacturer has foreseen and installed a proper pressure gauge. Repeat the above operation every time you stop the machine.

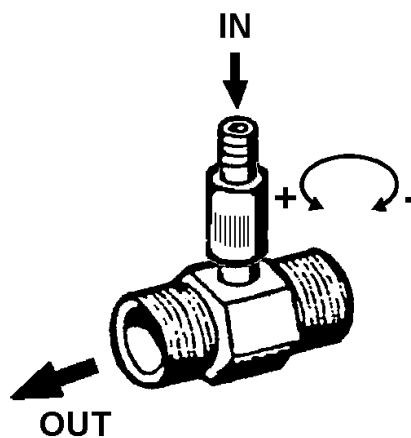

If the injector for detergent is installed on the valve, set the lance at low pressure and adjust the ring nut to get the required amount of product, mixed with water; if the injector is fixed type, the amount of detergent returned is pre-established from the injector size.

Working with an unloader valve with suction recycle, do not operate the pump in the by-pass condition (gun shut off) for more than 3 ÷ 5 minutes. This will result in damage to the pump and pump components. A safety thermal valve, set at max. temperature of 70 °C (158 °F), installed on the pump, reduces the possibility of overheating.

⚠ Do not tamper with the by-pass valve calibration. Operate only using the knob.

9.1 OPERATION WITH DETERGENT

CAUTION

- Use only the detergents recommended by the Producer of the machine incorporating the pump.
In particular, never suck fluids containing solvents, petrol, thinners, acetone and combustible oil, because the sprayed product is highly flammable, explosive and toxic.
- Carefully read all prescriptions and warnings on the label of the detergents in order to take the suitable measure not to generate dangers for you and for the environment.
- Preserve the detergents in a safe place that cannot be reached by children.
In case of contact with eyes, wash immediately with water and apply to a doctor by bringing with you the detergent package.
- In case of ingestion, do not induce vomiting and immediately apply to a doctor by bringing with you the detergent package.

To carry out correctly what described below, refer also to the use and maintenance manual of the machine incorporating the pump.

- a) Set the pump pressure below 30 bar/435 psi (for instance, in case of a water cleaner, this can be obtained by activating the low pressure operation on a lance with the suitable nozzle holder).
- b) If there is the possibility to adjust the detergent suction, operate on the knob: by screwing it you decrease the flow of the sucked detergent and by unscrewing it you increase it.

WARNING

To avoid deposits, after the detergent use it is a good habit to wash the passage ducts by sucking some water.



CAUTION: The high pressure jet, if used incorrectly, could result in personal injury or damages to the environment. Too high pressure may damage the objects that you require to wash; we recommend to carry out operating tests (working pressure, distance of the nozzle from the object, etc.) on waste materials.

Idromeccanica Bertolini S.p.A. declines any civil or criminal liability for damage or accidents to persons or property as may arise from the improper use of the pump, relevant accessories and motors/engines driving the pump.

10. SHUT DOWN PROCEDURE- CLEANING AND STANDSTILL

After use, if chemical products have been used, run the pump with clean water for a few minutes. Then empty the pump, by running the pump for about 20 seconds, without water supply. If freezing conditions are likely to be met, drain completely of pumped fluid or flush with anti-freeze liquid.

- In no case hoses must have fluid on pressure when stopping the pump.
- Carry out the cleaning and maintenance operations recommended by the Producer of the machine incorporating the pump.



Therefore make sure that:

- you have closed the water supply and then stop the pump.
- you have set the delivery pressure at **zero** bar as described in paragraph B.

11. STARTING PROCEDURE AFTER LONG TIME OF NO OPERATION

For pumps working in negative inlet pressure from tank, if they have not run for a long time, priming could be difficult.

For quick priming, force inlet pressure (1 | 3 bar), connecting for example water supply, and start the pump. Once priming is done and the operation is regular, reset the connection in negative pressure.

In some pumps, when starting-up (first minutes), you can notice a little leak of water from the seals; this is a normal factor because, specially in very hot climate conditions, the seals tend to get dry and they loose their elasticity. After working a few minutes, they re-absorb the normal humidity, and they will return to normal conditions.

CAUTION! Do not run the pump dry for a long time; this will result in premature pump failure. The inlet plumbing without elbows, of adequate diameter and fitted with an appropriate strainer makes priming easier. A quick priming of the pump prolongs pumping components and packings life.

12. LUBRICATION

Before each start-up, check the pump crankcase for a proper oil level; proper oil level is indicated by the red dot in the sight-glass or between the high and low marks on the dipstick (incorporated in the plug).

Use only oil SAE 75W-90

LUBRICANTS	
CASTROL	TAF-X 75W-90
PERSIAN	SINTEX GEAR 75W-90
STILMOIL	GEARING SUPER SYNT 75W-90
VALVOLINE	SYNPOWER GEAR OIL 75W-90

Change oil after the first 50 hours and then change oil every 500 hours (200 hours for pumps over 240 Bar) or every 6 months or every time you find quality degradation to the touch.

If the pump is used in humid climates, it is necessary to change oil periodically, and anyway, before finding out the emulsion with condensation (typical off/white colour).

If the pump is used at high temperatures, it is necessary to change oil more frequently in order to prevent the deterioration of lubricating properties.

When changing oil (500 hours or emulsion of water or 200 hours), clean crankcase inside removing all impurities, use degreasing products to be spread by brush and consequent disposal.

CAUTION: Operating pump with emulsified oil (with water, condensation, etc.) will reduce the lubrication of the moving parts and consequently will result in overheating and premature failures to the kinematic mechanism, Idromeccanica Bertolini cannot be hold liable.



**Protect the environment from liquids contained in the pump.
Collect residues and dispose of them regularly.**

13. ROUTINE MAINTENANCE

At each use check oil level and state.

Check every 50 hours:

- a) suction filter cleaning.
- b) The suction circuit (no leaks) and conditions of the hydraulic connections.
- c) Check fixing conditions of the pump to the motor / engine and to the structure.

Checks must be carried out daily if the pump is working in presence of vibrations



IMPORTANT CONDITION!: Nozzle is subject to wear, so it must be replaced every time that your pump will not reach the required pressure; in fact, when worn, the actual flow rate is increasing and pressure is decreasing.

14 TROUBLESHOOTING – PUMP/ UNLOADER BY-PASS VALVE

PROBLEM	PROBABLE CAUSE	SOLUTION
Pump runs normally but pressure is low	<i>Pump is sucking air Stuck valves Unloader valve faulty Nozzle of improper size Worn packings Worn valves</i>	<i>Check inlet circuit and possibility of air ingress Check and clean or replace if necessary Check and replace if necessary Check and replace if necessary Check and replace if necessary Check and replace if necessary</i>
Fluctuating pressure	<i>Jammed valves Pump is sucking air Worn packings Worn nozzle</i>	<i>Check and clean out if necessary Check inlet circuit and possibility of air ingress Check and replace if necessary Check and replace if necessary</i>
Pressure low after normal period of use	<i>Worn check valves Jammed check valves Worn unloader valve seat Worn packings Air in suction</i>	<i>Check and replace if necessary Check and clean out if necessary Check and replace if necessary Check and replace if necessary Check suction line</i>
Noisy Pump	<i>Inlet plumbing of improper size or broken spring of the discharge valve Worn bearings Excessive temperature of water</i>	<i>Check and replace if necessary Check and replace if necessary Reduce temperature</i>
Presence of water in oil	<i>Worn oil seal High humidity in air Worn packings</i>	<i>Check and replace if necessary Check and change oil more frequently Check and replace if necessary</i>
Water dripping below pump	<i>Worn packings Worn O-Ring plunger retainer</i>	<i>Check and replace if necessary Check and replace if necessary</i>
Oil leaks	<i>Worn oil seal</i>	<i>Check and replace if necessary</i>
Change of pressure when gun is off	<i>Leaky gun and/or pressure line Worn non return valve Worn O-Rings</i>	<i>Renew gun and seals of the pressure line Consult Authorized Service Centre</i>
Water leaks from the piston (spring holder)	<i>Worn O-Rings</i>	<i>Consult Authorized Service Centre</i>
Excessive water return in by-pass at the operating pressure	<i>Too small nozzle Worn poppet and/or seat</i>	<i>Install correct nozzle Consult Authorized Service Centre</i>
Pressure gauge shows pressure fluctuations when gun is on	<i>Dirty valve Worn packings Worn check valve</i>	<i>Clean valve and lubricate parts Check and replace if necessary Check and replace if necessary</i>
Pressure is not Set at zero on the pump when shutting off gun	<i>Worn non return valve Worn O-Rings Gun is shutting off too slowly</i>	<i>Check and replace Check and replace if necessary Consult Authorized Service Centre</i>
Too high pressure on the hose when the gun is shutting off	<i>Excessive setting of the pressure spring Piston is not running smoothly</i>	<i>Consult Authorized Service Centre Consult Authorized Service Centre</i>
Operating pressure is not attained	<i>Too large nozzle Worn poppet and/or seat Low pump flow</i>	<i>Install proper nozzle Consult Authorized Service Centre Check pump (see above for the same problem)</i>

15- LIMITED WARRANTY

The liability of the manufacturer under the period of warranty (12 months from date of manufacturer's shipment) is limited to the replacement of the parts that, upon examination, appear in Bertolini's satisfaction to have been defective in material or workmanship.

This warranty is valid only when the fault is ascertained by its technicians, it shall not apply to any pump which have been repaired or altered to adversely affect the performance or reliability of the pump.

This warranty does not apply to malfunctions caused by fault or negligence of the buyer or third party, to the improper use of the pump, to failures reported to the manufacturer after the warranty period has expired, or to the normal wear of the component parts of the products such as seals, cups, O-Rings, valves, etc.

Costs of labour, packages and transport costs are at the Buyer's charges . Products, after receipt pf written factory approval, must be returned complete with all parts and not tampered. Otherwise warranty is void.

This warranty is subject to the following conditions:

- *Pump must be used within the specifications indicated in this manual and in the manual of the machine where the pump is installed. A safety valve must be correctly installed in the system.*
- *The warranty is void if pump is operating without sufficient fluid to the pump (cavitation).*
- *The warranty is void if pump is operating without oil in the crankcase.*
- *Protect pump from freezing. Do not store in area with freezing conditions. Drain completely of pumped fluid. Flush with antifreeze. Do not store or operate in excessively high temperature areas or without proper ventilation.*
- *The warranty is void if installation is not correct.*
- *The warranty is void if the recommended maintenance instructions are not observed.*
- *Different uses of the pump than the ones mentioned in the paragraph "Intended Use".*
- *The warranty is void if the pump use does not conform to the specific current safety standards and if the machine incorporating the pump is without CE marking.*
- *Use of non-original spare parts or even not suited for the pump model.*

USE OF OTHER THAN BERTOLINI PARTS VOIDS THE WARRANTY

ANY PRODUCT MUST BE RETURNED FREE BERTOLINI FACTORY PARTS RETURNED MUST HAVE FACTORY APPROVAL DOCUMENTATION PRIOR TO RETURN.

ROUTINE SERVICE AND REPAIR

A- PUMP

A1- Check valves service

Remove the check valves by unscrewing the six valve caps on the pump manifold (head) with an appropriate Allen wrench.

With the help of a small screwdriver, remove the check valves and their O-Rings from the manifold, taking care not to damage the sealing surface.

Lubricate with grease, insert the new O-Rings on the bottom of each housing and then the check valves. Be careful that the valve position is perpendicular to the bottom of its housing. Replace O-Rings on the covers and tighten to the proper torque (see chart below).

TORQUE SETTINGS FOR CHECK VALVES CAPS

SERIES	TORQUE
WEL-WESL-WE-WES-WSG	70 Nm*
HG-ALG	50 Nm*
WJL-WJC-WJS-WJH-WJG	50 Nm*
BX-WJCU-WB-WBX	22 Nm
WM	70 Nm
TW-TWS-TWSG-KWE	120 Nm
TML	70 Nm
TTV-KTV-TTL-TTK-KTL-RA	70 Nm
KKV-KKL-RB	100 Nm
HD (bolts M12)	70 Nm

*After each check valve service, apply Loctite or equivalent sealant to the check valve cover threads and tighten to the proper torque.

CAUTION!: If you are not sure about the right torque, apply a little amount of Loctite 243 or equivalent sealant to the valve cover thread.

Idromeccanica Bertolini S.p.A. declines any civil or criminal liability for damages or accidents to persons or property, due to a bad torque of the check valves covers, voiding any warranty claim.

A2- Packings/ seals service

Remove the head bolts using a proper Allen wrench and remove the head.

Operate with care to prevent damage to the ceramic plungers, if necessary, use a plastic or a rubber hammer. Remove the packing assemblies from the pump head, using a proper packing extractor. Install the new packings, eventually replace also the O-Rings, which may be worn, and fit them in the pump head housing, which has been previously lubricated with water-proof grease. Place the central plunger of the pump to the top dead centre (all outside), lubricate plungers with water-proof grease and insert pump head by keeping it square to the pump, being careful not to force on the plungers which may get damaged.

A series of packing extractors are available, upon request, to make this operation easier.

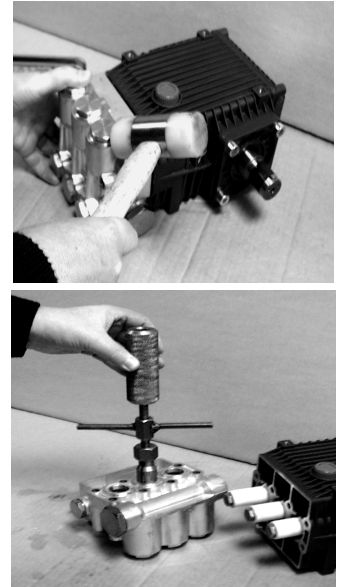

A3- Ceramic plungers service

Loosen the nuts and remove the plungers, clean with care the plunger rods surface.

Replace and lubricate the O-Rings and the anti-extrusion rings of the plungers rods, then install the new plunger, rotate it slightly to prevent any damage to the seals. Replace washer, apply a little amount of Loctite 243 or equivalent sealant to the thread and tighten nut to 13 Nm. torque.

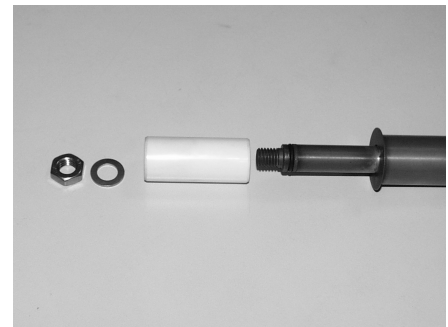

CAUTION: exercise caution not to overtorque the nut. It must be installed with the specified sealant to prevent premature failure to the ceramic plungers.

NOTE: the picture is only an example. Components are not the same for all series. Follow the parts list and the exploded drawing supplied with each product.

B- AUTOMATIC UNLOADER VALVE



CAUTION: Servicing of the unloaders must be done only by skilled personnel. Do not service unloader and contact your local distributor.

1 Leaky poppet

- With a 22 mm fork wrench loose completely the hexagon 4 and remove the cartridge 5 from the valve body.
- Remove seat 6.
- Check O-Ring 8, which must be intact. If necessary replace it.
- Check seat 6, it must not be dented in its internal edge, if necessary, replace it.
- Check the conic surface of poppet 7, it must not be dented, if necessary, replace it (see following step 2)

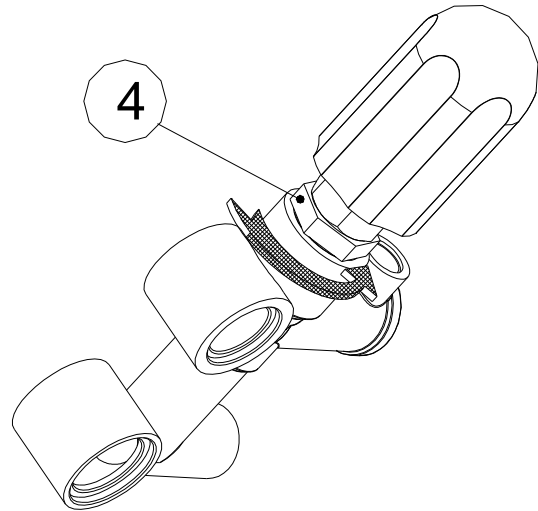

2 piston

- Remove cartridge 5 from the valve body, loosen completely the adjusting knob 1.
 - Remove spring 10 from the cartridge 5 and be sure that it can run free inside the seat.
 - By one finger press into the head of poppet 7, check that piston 9 is running freely.
 - Hold steady the head of poppet 7, use a 10 mm. fork wrench to loose, by a screwdriver, the piston 9 and remove it.
 - Examine the O-Rings 11 and 12, if worn. Replace, if necessary.
 - Lubricate the spring and the piston before reassembly.
- Apply one drop of Loctite to tighten head 7 on piston 9.

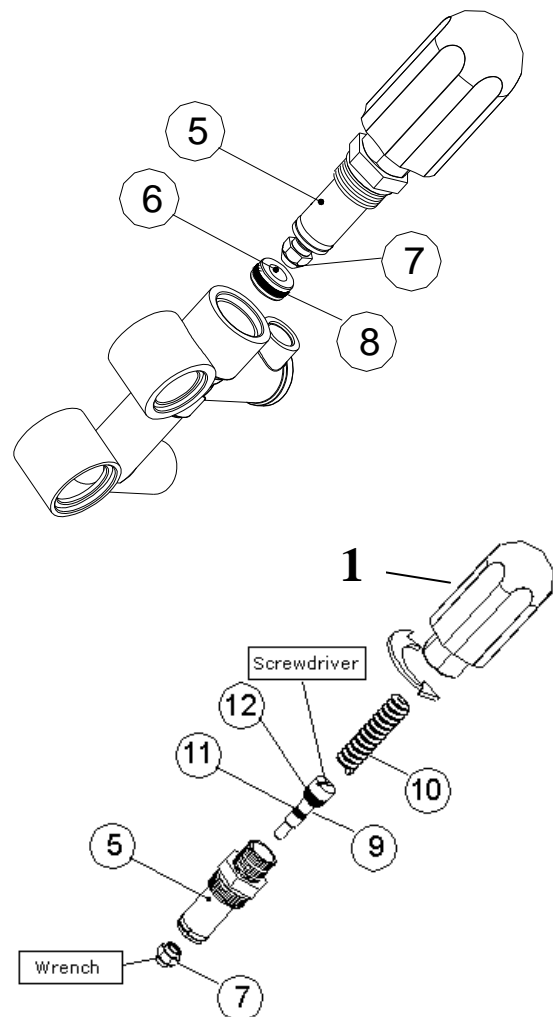

3 nonreturn valve

- Loosen the outlet nipple 13
- Examine spring 14
- Examine O-Ring 16

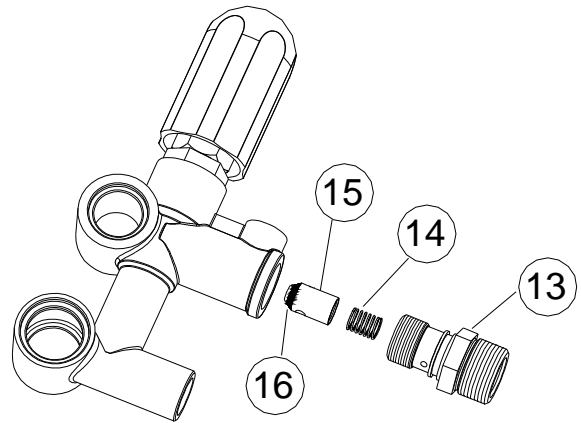



Manufacturer's Declaration

Machines Directive **2006/42/CE** (Attachment II point B)

Idromeccanica Bertolini S.p.A.:
declares under its sole responsibility that the pump series

ALG – BXH-F – BXG – WJC-U – WBL –WBL-F –WBS – WBS-F – WBC – WBC-F – WBH – WBH-F – WBG – WBG-W – WBX – WBXL-F – WBXG – WML – WML-F – WMC – WMC-F – WMS – WMS-F – WMH –WMH-F – WMG – WMG-W – TM-S – TML – TML-F – TML-HP – TMS-HP – TMS – TMS-F – TMH – TMH-F – TMG – AKML – AKMS – TTV – KTV – KKV – HD – **TTL – TTK – KTL – KKL –RA-S – RB-S** – RAL – RAS – RAL-H – RAS-H – RB – RBL – RBS

with the serial number
(to be filled in by purchaser according to identification label)

-is manufactured to be incorporated in a machine or to be assembled with other equipment to form a machine provided for by Directive **2006/42/CE**;

-the producer of the machine, that incorporates the pump, is the only one responsible of the accordance in every point to this Directive's standards.

Therefore Idromeccanica Bertolini S.p.A. declares that the above pump must not be put into operation up to the machine in which it will be built-in will be identified and will be declared in compliance with the Directive's standards **2006/42/CE**.

Reggio Emilia **10.10.11**

Managing Director: L. Quaretti

