



Monsoon Series

Single Phase High Pressure Washer
& Grit Blaster

March 2018

Operator's Instruction Manual

Covers:

Monsoon 100

Monsoon 140

BERTOLINI[®]
pumps
4 year warranty



Operators must read this manual &
understand it before operating this machine

Ref: MONSP0318

Aussie Pumps

AUSSIE HIGH PRESSURE BLASTER RISK ASSESSMENT

MODELS:

In line with the National Occupation Health & Safety Commission's requirements the data below applies to the Aussie Scud range of high pressure water blaster models:

- Monsoon 100
- Monsoon 140

DESCRIPTION:

Electric drive high pressure cold water blasters designed for professional cleaning applications.

MATERIAL CONSTRUCTION:

Aussie Monsoon Scud pressure washers are mounted on heavy duty trolley mounted frames. They consist of a quality 4 pole electric motor driving a triplex style three piston high pressure pump. The machines are supplied with wheels for ease of portability and manoeuvrability. The machines can be supplied with hose reels and up to 30 metres of high pressure hose to increase operator convenience.

RISK RANKING METHOD:

Risk is the combination of the likelihood of a specific unwanted event and the potential consequences if it should occur.

RISK RANKING METHOD:

For each event, the appropriate probability (a letter A to E) and consequences (a number 1 to 5) is selected.

PROBABILITIES:

- A. Common or repeating occurrence.
- B. Known to occur or "it has happened".
- C. Could occur, or "I've heard of it happening".
- D. Not likely to occur.
- E. Practically impossible.

CONSEQUENCES FOR PEOPLE:

1. Fatality or permanent disability.
2. Serious lost time, injury or illness.
3. Moderate lost time, injury or illness.
4. Minor lost time, injury or illness.
5. No lost time.

RISK RANKING TABLE:

The consequences (loss outcomes) are combined with the probability (of those outcomes) in the risk ranking table to identify the risk rank of each loss event (e.g. a consequence of 3 with a probability of B yields a risk rank of 9).

The table yields a risk rank from 1 to 25 for each set of probabilities and consequences. A rank of 1 is the highest magnitude or risk that is a highly likely, very serious event.

A rank of 25 represents the lowest magnitude of risk, an almost impossible very low consequence event.

Controls must be taken to either eliminate or minimise the risk.

C O N S E Q U E N C E	PROBABILITY				
	A	B	C	D	E
1	1	2	4	7	11
2	3	5	8	12	16
3	6	9	13	17	20
4	10	14	18	21	23
5	15	19	22	24	25

POTENTIAL HAZARD:

Hazard	Yes/No	Risk	Risk Rating	Controls
Entanglement with hose (tripping, falling)	Yes	Personal injury of the operator or bystanders	13	<ul style="list-style-type: none"> ◆ Warning stickers ◆ hose reel option
Injury from high pressure water	Yes	Personal injury of the operator or bystanders	13	<ul style="list-style-type: none"> ◆ Warning notice on blaster ◆ Warning in Operator’s Manual, ◆ Use of safety protection clothing (Aussie Pro-operator) ◆ Use of barriers to keep bystanders away from work area
Ergonomic lifting or movement on site	Yes	Personal injury	8	<ul style="list-style-type: none"> ◆ Machine decal warning about correct lifting procedures ◆ Operator’s Manual ◆ Staff training
Electrocution	Yes	Personal injury	12	<ul style="list-style-type: none"> ◆ Warning sticker ◆ Disconnect from power before servicing machine
Unsecured machine, moves unattended	Yes	Cause of accidents and/or injury	18	<ul style="list-style-type: none"> ◆ Warning sticker “Secure Machine during Operation” ◆ Operator’s Manual
Dislodged particles in atmosphere	Yes	Sight damage	6	<ul style="list-style-type: none"> ◆ Warning regarding wearing safety glasses.
Slipping on wet surface	Yes	Personal injury	9	<ul style="list-style-type: none"> ◆ Use of proper footwear
Contact with chemical cleaners used to clean surfaces	Yes	Skin contact could result in burns, skin irritation etc. Fumes from some chemicals may lead to respiratory problems	4	<ul style="list-style-type: none"> ◆ Chemical cleaners to only be used as a last resort when other methods have failed. ◆ Areas to be kept well ventilated. ◆ Staff to follow manufacturers’ instructions at all times for use, storage & disposal. ◆ Staff to wear the appropriate PPE ◆ Respiratory protection when required

Signed originator

Job title

Date Completed

AUSSIE ECO CLEAN BLASTER OPERATING & MAINTENANCE INSTRUCTIONS

**** WARNING ****
AUSSIE MONSOON SERIES HIGH PRESSURE WATER BLASTERS ARE DESIGNED FOR PROFESSIONAL OPERATORS ONLY
IMPORTANT
INSTRUCT OPERATORS IN CARE AND USE OF THE MACHINE BEFORE USE!

Contents:

Blaster Risk Assessment	2	Care & Maintenance	9
Safety precautions	5	Instructions for use of grit blast kit	10
Specifications	5	Troubleshooting	11
Assembly & preparation for use	6	Parts identification	12
A. Machine preparation	6	Replacement parts	13
B. Hose connections	7	Pump parts	14
C. Before starting the machine	8	Service notes	15
D. Starting the electric motor	8	Warnings	16
E. Pressure washing	8	Pressure cleaner daily checks	16
F. Applying detergent	8	Three monthly regular service	16
G. Stopping the machine	9		

CONGRATULATIONS on the purchase of an Aussie Monsoon Scud professional high pressure water blaster. These top of the range machines have been designed to be easy to use, simple to service and offer reliability and performance.

Before attempting to operate your machine please read this Instruction Manual thoroughly following all directions carefully. By doing so you will ensure safe operation of the unit and will enjoy long and trouble free service from your heavy duty water blaster.

GUARANTEE ... EXCLUSIVE 4 YEAR PUMP

This Aussie Eco Clean product is guaranteed against faults in manufacture for two years from purchase. The Bertolini pump has a four year warranty, but must be serviced by an authorised service agent every six months to maintain this warranty. Keep your receipt as proof of purchase and all service receipts. This guarantee is invalid if the product is found to have been abused in any way, or not used for the purpose for which it was intended.

Routine maintenance is the owner's responsibility. Failure to maintain the machine in line with the services outlined on the back page will invalidate warranty. High pressure accessories carry a 3 month warranty.

Where possible return faulty goods to the place of purchase. No products can be returned to us without our prior permission. The reason for return must be clearly state.

N.B. Warranty is not transferrable to third parties in the event of sale of the machine within the warranty period. Please note that any parts used in warranty repairs are guaranteed for a period limited by the original warranty of the parent product.

Our goods come with guarantees that cannot be excluded under the Australian Consumer Law. You are entitled to a replacement or refund for a major failure and for compensation for any other reasonably foreseeable loss or damage. You are also entitled to have the goods repaired or replaced if the goods fail to be of acceptable quality and the failure does not amount to a major failure.

The benefits under the Aussie Pump warranty are in addition to other rights under Australian Consumer Law.





SAFETY PRECAUTIONS - IMPORTANT

1. **NEVER** direct the spray jet at any person or animal. Keep hands and feet clear of the cleaning nozzle at all times.
2. **NEVER** direct spray jet at any surface that may contain asbestos material.
3. **NEVER** hold a finger over the high pressure nozzle.
4. **NEVER** direct the spray jet at the machine itself or any electrical equipment.
5. After use release the pressure in the high pressure hose by operating the gun trigger.
6. **DO NOT** attempt any mechanical repair. If you have a problem with your machine contact your local Aussie Eco Clean Service Division, phone (02) 8865 3500.
7. **NEVER** supply any liquid other than water to the pump inlet.
8. **DO NOT** run dry
9. **NEVER** pull the high pressure hose if it has formed kinks or nooses.
10. **NEVER** pull the hose over sharp objects.
11. **DO NOT** join high pressure hoses. The connectors may leak and cause the unloader to wear prematurely. Buy extra length hoses if extended range required.
12. **DO NOT** attempt to disconnect any hose or coupling with pressure still in the hose.
13. **DO NOT** operate the machine whilst standing on ladders, use a platform tower or scaffolding.
14. Operate in well ventilated areas only.
15. **DO NOT** operate if power cable is damaged, contact a certified electrician for replacement.
16. **DO NOT** try to repair a leak in the hose or connection while the system is under pressure.
17. **DO NOT** substitute any component part on this machine. Use of incorrect parts could cause serious personal injury.
18. Children should **NOT** be allowed to use the machine.
19. We recommend the use of safety goggles and steel cap boots when using the machine.



SPECIFICATIONS

Model	Pump Pressure (psi)	Pump model	EWP	Flow rate (lpm)	Motor	Pump rpm	Weight (kg)
Monsoon 100	1600 (110 BAR)	WBL1114	2800	11	3HP 2.2kW, IP56	1450	45
Monsoon 140	2000 (140 BAR)	WBL917	3400	9	3HP 2.2kW, IP56	1450	45

* NB: Performance using 15 amp plug option



FRAME & WHEEL CARE MAINTAIN OPTIMUM PERFORMANCE

Aussie Monsoon blasters now come fitted with top quality **flat free tyres**. To maintain tyre shape ...

1. Ensure that straps used to secure the unit during transit are not over tightened to the point where tyres misshape.
2. Do not leave the unit strapped down for extended periods.
3. Do not drop the unit; this could cause frame distortion or damage bearings.



ASSEMBLY & PREPARATION FOR USE

Before proceeding with assembly of your new Aussie Eco AB high pressure blaster, check that all parts listed below are included.

- . 1 Gun with melted handle
- . 1 Vario lance
- . 1 High pressure hose
- . 1 Grit blast kit



A. Machine Preparation (initial start-up)

1. Check the oil in the pump.
With the machine on a level surface the oil lever should cover the red spot in the oil level sight glass on the front of the machine. If necessary, top up with SAE 75W-90. Do not mix different grades of oil as this may affect the machines performance. If alternative oil is used, first empty out oil by unscrewing drain plug in bottom of machine.

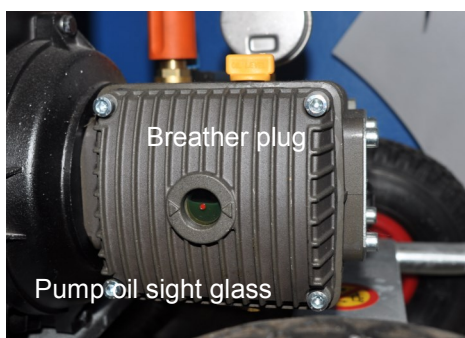

2. Ensure breather plug is fitted to pump.
WARNING: Before operation ensure top mounted travel plug is replaced by breather plug. Failure to fit breather and keep clean can result in over pressuring of oil chamber (crank case) and can blow oil seals. This will void warranty.
3. Plug in machine to suitable power supply.
NOTE: Unit supplied with a 15 amp plug. A 10 amp plug can be retro fitted but the pump pressure will need to be adjusted down to reduce amps drawn by the motor. This should only be done by a qualified technician.

4. Assemble gun/lance assembly.

VARIO LANCE: To assemble the lance, insert lance into gun and screw together.

B. Hose Connections

1. Connect high pressure hose to machine outlet.
2. If optional low pressure downstream, in-line chemical injector is to be used, connect the injector tube to the detergent inlet and place the other end of the tube, with the strainer attached, in the chemical container (not supplied).
3. Connect gun/lance assembly to high pressure hose.
4. Check inlet water filter is clean then connect water supply hose to machine. Use a 25mm (minimum) hose .

Incoming water supply must deliver double the flow of the machine. If questionable, check supply at machine. If supply is insufficient, do not operate from this outlet. For residential use, the outlet closest to the meter will usually deliver the highest flow rate. Connect only to clean town water supply.



Warning: Do not operate from tank or pond. Doing so will cavitate the pump causing damage. Cavitation or pump starvation is not covered by warranty. Cavitation is a phenomenon causing vacuum pockets to form within the pump that eventually implode under pressure pitting the internal pump surfaces.

Aussie Safety Protection Kit

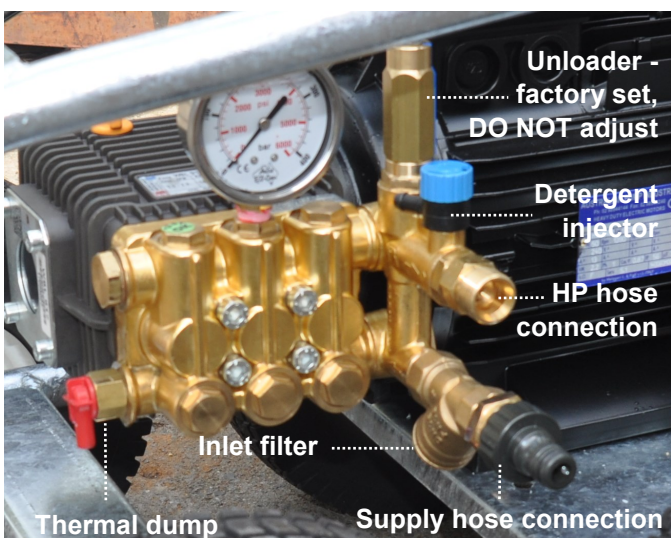

HIGH PRESSURE SPRAY CAN PENETRATE THE SKIN AND CAUSE SERIOUS INJURY!

NEVER POINT THE SPRAY GUN AT YOURSELF, OTHER PEOPLE OR ANIMALS.

SHOULD SPRAY PENETRATE THE SKIN, SEEK MEDICAL ATTENTION IMMEDIATELY!

Fitting Instructions for Optional Hose Reel (Part number AD300001)

- Fit hose reel to the mounting bar using the four sets of nuts and bolts supplied. Ensure all bolts are securely tightened and use Loctite to prevent them vibrating loose.

The reel should be positioned so that it rotates fore/aft to aid fitting whip hose.

- Connect whip hose to high pressure outlet on pump.
- Fit handle to reel.
- Fit gun to hose using C1500.180 nipple.

Start up machine (see below) and check for leaks. All leaks must be rectified before using machine.

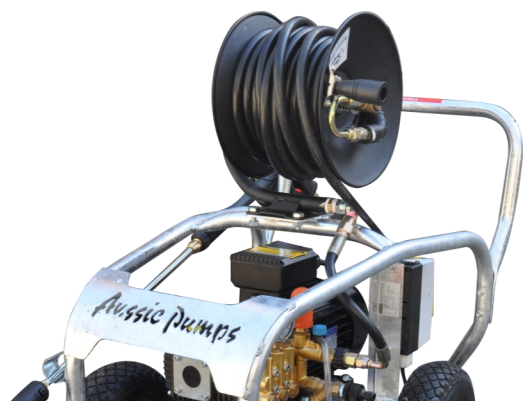

UNLOADER SETTING

The high pressure unloader on the machine is factory set to operate the pump at it's rated pressure.

DO NOT ADJUST. Tampering with the unloader will void warranty and can be dangerous.

C. Before starting the machine

1. Ensure machine is level
2. Turn on water supply.
3. Pull gun trigger until water starts to flow in a steady steam then release trigger.

D. Starting the electric motor

1. Turn on the motor
2. Check that there are no leaks in the line connections, gun or lance. Pressure begins with the gun trigger is squeezed.

**KEEP THE MACHINE OUT OF
MOISTURE LADEN ATMOSPHERES**

E. Pressure washing

WEAR PROPER FACE PROTECTION WHEN OPERATING PRESSURE WASHER!

1. For high pressure jetting the black plastic lance head should be pushed fully in. Rotate the plastic head to adjust the angle of the spray jet.
2. When low pressure and high flow is required, including detergent application, pull the plastic lance head out until it clicks

NOTE: Check the system for water leaks, oil leaks, hose kinks, etc. Correct any problems before proceeding.

Machine is now ready for operation.

WARNING DO NOT RUN EXCESSIVE BY-PASS

SWITCH MACHINE OFF WITHIN TWO MINUTES OF CEASING OPERATION AS EXCESSIVE BY-PASS CAN CAUSE HEAT BUILD UP IN PUMP AND SUBSEQUENT DAMAGE.

EXCESSIVE BY PASS RUNNING VOIDS WARRANTY!!

F. Applying detergent

1. Prepare pressure washer detergent solution as required by manufacturer.
2. Place detergent siphon tub/filter into solution.
3. Adjust lance to low pressure setting.
4. Apply cleaning solution to a dry surface, starting at lower portion of areas to be washed and work upward, using long overlapping strokes.
5. Allow time to detergent to activate and then rinse off. DO NOT allow detergent to dry on.

IMPORTANT;

You must flush the injection system after each use by placing siphon hose into a bucket of clean water, then run pressure washer in low pressure for 2 minutes.

G. Stopping the machine

1. If using the detergent injector, flush out the chemical by running clean water through the system.
2. Allow machine to run for 1 minute without load to cool before stopping.
3. Turn motor switch to OFF
4. Turn off water supply.
5. Pull gun trigger to release all pressure in the system, then LOCK THE TRIGGER.
6. Hoses may now be disconnected from the machine.

Failure to release pressure before disconnecting the hose quick coupler will result in the quick coupler o-ring seal blowing out. This o-ring must be replaced before operating machine.

CARE AND MAINTENANCE:

AFTER EACH USE

If cleaning agents have been mixed with the incoming water, it is essential to flush the machine with clean water after use.

If there is a danger of freezing anti-freeze should be mixed with the flush water or the machine must be completely drained.

After the final flush stop the machine. DO NOT allow the machine to idle for more than 15 seconds. This is particularly important when there is a danger of freezing. Do not run for longer without water supply.

STORAGE

Store the washer in an upright position, preferably drained of water if there is a danger of freezing (or fill with anti-freeze).

PUMP CRANKCASE LUBRICATION

Proper pressure washer pump crankcase lubrication will help extend the working life of the machine. Follow these important guidelines. We recommend keeping a simple service log book.

- Change oil in pump after initial 50 hour run-in period. (SAE 75W-90)
- Change pump oil every 3 months, use high quality oil. (SAE 75W-90)
- Pump oil level can be checked with the dip stick under the breather cap or by viewing the oil sight gauge where fitted. The oil level is correct if level is in the centre of the gauge. If oil level is low, fill to correct level with recommended oil (SAE 75W-90). **DO NOT OVERFILL CRANKCASE!**

PREVENTATIVE MAINTENANCE

- Keep filter in supply hose connection clean, rinse regularly.
- Drain water from pressure hoses, gun/lance assembly and accessories after use.
- Protect pump from freezing. Failure to remove water from the pump in freezing temperatures will result in damaged pump manifold.
- Use ONLY injector of the size and type designed for this model.
- **DO NOT** tamper with unloader valve adjustment.
- **DO NOT** siphon chemicals through the pump, it is designed for water only.
- Incoming water supply must not exceed 60°C, otherwise pumps seal damage could result.

Instructions for use of grit blast kit



WARNING: To reduce the risk of injury, always protect eyes and face with goggles and mask, and hands and arms with heavy work gloves when spraying abrasive materials.

1. Connect lance of grit blast kit in to gun in place of the vario lance.
2. Place the sand probe in the sand container.

How To Sandblast :

1. Connect and open the water supply line before starting the pressure washer.
2. Squeeze the gun trigger to release air in the equipment.
3. Turn on the pressure washer.
4. Squeeze the gun trigger to activate the spray.
5. **CAUTION:** Always test spray on a scrap of similar material first! The high pressure spray could damage the surface if the grit blaster is held too close.

To determine best distance for grit blasting, start with the spray nozzle a metre away from the

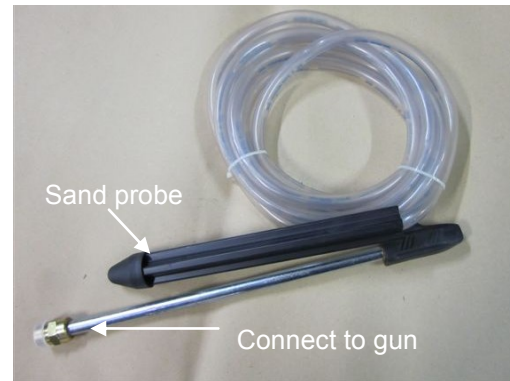

surface and gradually move closer, frequently checking the surface for damage.

6. Always point the nozzle downward when not spraying. This prevents water from entering the sand supply. If water does get into the sand supply hose, remove the probe from the sand, hold the gun trigger open, and let the hose air dry. Always be sure the sand hose is dry before using.
7. Keep the sand covered to prevent the overspray from wetting the sand. Do not allow small pieces of the sand bag to fall into the sand supply. A smaller piece could prevent the flow of sand.

Recommended grit

Task	Sand Mesh	Sand Type	Blasting Angle
Paint from Metal	20/40	Round Silica i.e river sand	0-30
Paint from Masonry	20/40	Round Silica	0-20
Rubber Base Paint from Masonry	10/35	Angular i.e. crushed rock	0-15
Paint from Wood (coarse, rough cut effect)	40/60	Round	1-10
Paint from Wood (smoother, driftwood effect)	20/40	Round	1-10
Metal Scale	20/40	Round	0-15
Rust	16/50	Angular	0-25

Troubleshooting

No Sand	Blocked sand probe.	Clear obstruction and make sure air vents in sand probe are open
	Blocked nozzle.	Remove mixing nozzle and clean
	Wet sand	Dry or replace sand
	Low vacuum	Valve open; air leaks in system. Tighten hose clamps.
Not enough sand	Incorrect water nozzle	Change spray angle
	Collapsed hose	Replace hose or remove restriction
	Partial obstruction to sand probe	Clear obstruction from sand probe inlet
	Low sand level	Change probe to new bag of sand
	Low water pressure &/or flow rate	See machine troubleshooting chart

TROUBLE SHOOTING GUIDE

FAULT	CAUSE	REMEDY
Pump running normally but pressure low on installation	Pump sucking air Valves sticking Unloader valve seat faulty Nozzle incorrectly sized Worn piston packing	Check water supply and possibility of air ingress. Check and clean or replace if necessary Check and replace Check and replace Check and replace
Fluctuating Pressure	Valves worn Valves blocked Pump sucking air Worn piston packing	Check and replace Check and replace Check water supply and air ingress at joints in suction line Check and replace
Pressure low after period of normal use	Nozzle worn Check valves worn Check valves blocked Unloader valve seat worn Worn piston packing Cracked pistons as a result of dry running	Check and replace Check and replace Check and clean Check and replace Check and replace Replace pistons
Pump Noisy	Air in suction Broken or weak suction or delivery valve spring Foreign matter in valves Worn bearing Excessive temperature of liquid	Check water supply and connections on suction line Check and replace Check and clean Check and replace Reduce temperature
Presence of water in oil	Oil seal worn High humidity in air Piston packing worn	Check and replace Check and change oil twice as often Check and replace
Water dripping below pump	Piston packing worn O.R plunger retainer worn	Check and replace Check and replace
Oil Dripping	Travel plug in use on pump Oil seal worn	Replace with breather plug Check and replace if necessary
Unloader switches repeatedly when gun is off	Leaking gun and/or pressure pipe. Leaky sleeve Worn out kick-back valve body Leaky seals	Renew gun, seal pressure pipe Renew sleeve Check and renew as necessary kick-back valve plate and seat Renew seals
Leaky piston rod	Defective O-Ring/Support Ring	Renew piston rod seals and examine surfaces in guide case
Leaky by-pass at nominal pressure	Nozzle too small, too much water. Worn out by-pass valve	Install larger nozzle Examine and renew as necessary, poppet (16 for APR-11 for VD valves - 10 for ADV-8 for Unifit valves), valve set (14 or APR-12 for VD valves - 11for AVD valves - 7 for Unifit) and by-pass valve body.
Pressure gauge shows high pressure fluctuations when shutting off gun	Valve set too high above operating pressure Dirty valve	Adjust the unloader at the operating pressure. Clean valve (removing lime deposits etc). Grease parts before installing.
Motor hums when switched on but does not start	Mains voltage too low Spray gun not activated Cross section of extension lead too small	Check electrical connection Activate spray gun when switching on Use correct dimension extension lead

PARTS IDENTIFICATION

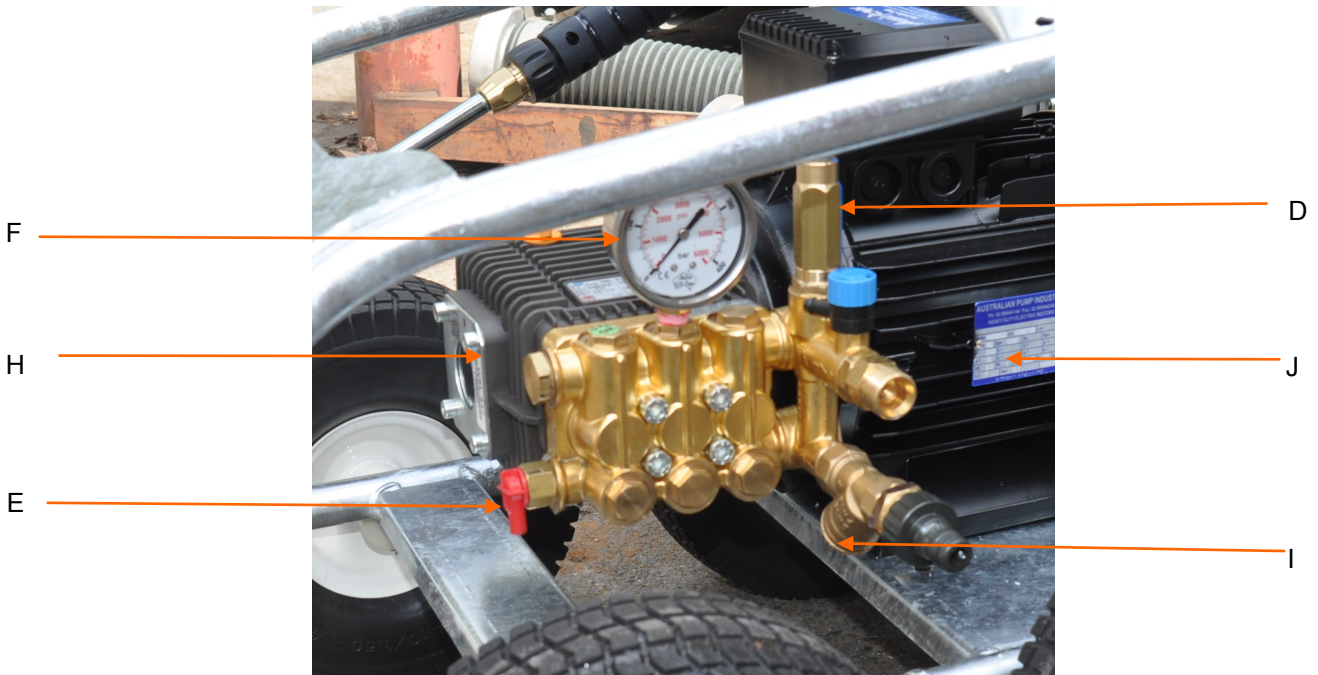

REPLACEMENT PARTS

Position	Part No	Description	Monsoon	
			100	140
Lance & Gun				
A	C4723.45.115	T10 VARIO LANCE	x	x
B	M4021108007	AL13 GUN WITH MELTED HANDLE& QC M22	x	x
Hose				
C	AR206FB6FB6X8	8 MTR HP HOSE (R2, 3000 PSI)	x	x
Unloader				
D	BAPR-I-25ADJ	UNLOADER VALVE (2000 PSI)	x	x
Thermal Dump Valves				
E	MPA60063050	THERMAL DUMP VALVE 3/8"	x	x
Gauge				
F	AGCDR0102	6,000 PSI PRESSURE GAUGE	x	x
Switch				
G	ASWITCHASSYMON	ON/OFF SWITCH (16 AMP)	x	x
Pumps				
H	BWBL1114	BIG BERTY PUMP (1600 PSI, 11 LPM)	x	
	BWBL917	BIG BERTY PUMP (2000 PSI, 9 LPM)		x
Strainer				
I	AY STRAINGER-200	BRASS Y STRAINER 1/2"	x	x
Electric Motor				
J	A140060M001	3HP MOTOR 2.2KW	x	x
Wheel				
K	A400015	10" WHEEL (EACH)	x	x
Optional Hose Reel				
	AD30001	STEEL HOSE REEL WITH 15M R2 WIRE BRAID HOSE	x	x
	C1500.180	NIPPLE (3/8" F x M22) FITS GUN TO HOSE ON REEL	x	x

PUMP PARTS WBL 917, 1114

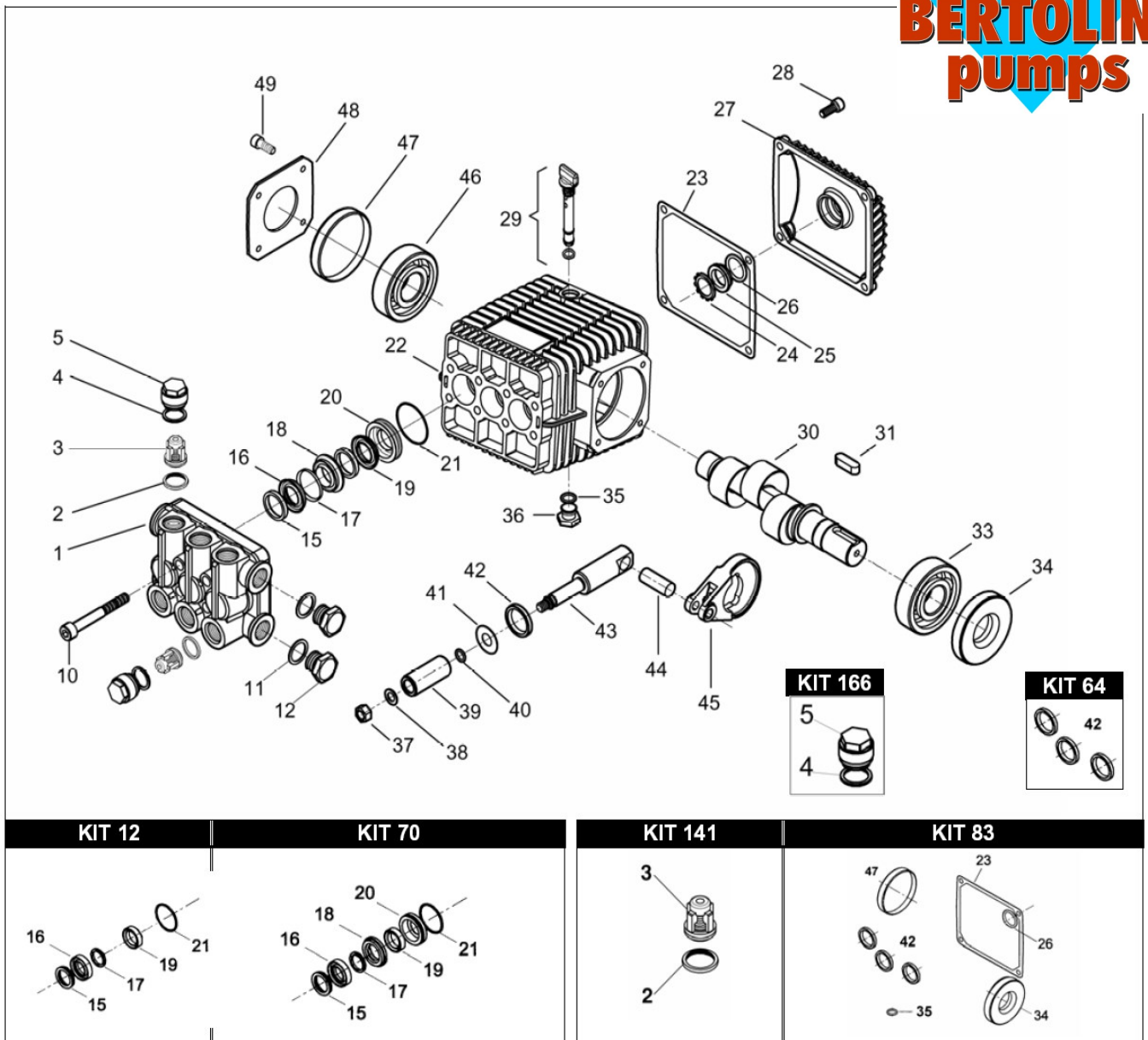

Kit/Position No.	Part No.	Description
Kit 141	B019826973	Valve Kit (12 pieces)
Kit 12	B049813973	Seal Kit Minor (15 pieces)
Kit 70	B049841973	Seal Kit Major (21 pieces)
Kit 83	B049847973	Oil Seal Kit (8 pieces)
Position 25	B040120322	Oil sight glass
Position 29	B049832973	Oil breather plug
Position 39	B050010182	18mm ceramic piston (3 needed)
Aussie pressure test set		Aussie pressure test set includes gauge and fitting for testing pump output pressure and Bertolini Pump Selection Guide

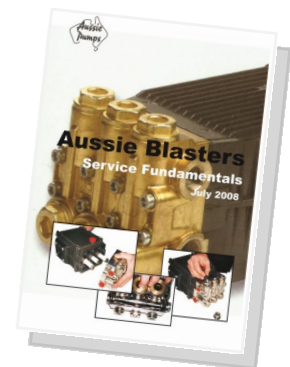

Order the right part first time ... specify the pump model number when ordering parts.

Full parts breakdowns available online ... www.aussiepumps.com.au



WARNING

OVERSPEEDING

Do not operate machine at over 3200rpm (motor speed). Over speeding can cause serious pump damage.

EXCESSIVE BYPASS

Do not run on excessive by-pass. Switch machine off within two minutes of ceasing operation as excessive by-pass can cause heat build up in pump and subsequent damage. Excessive bypass running voids warranty.

HIGH PRESSURE SETTING

The high pressure pump is factory set to operate at its rated pressure. DO NOT ADJUST. Tampering with the pressure regulator will void warranty and can be DANGEROUS.

PRESSURE CLEANER DAILY CHECK LIST

- . Check pump oil level
- . Check all high pressure components for leaks:
 - . gun/lance
 - . HP hose
 - . all fittings
- . Check water filter and clean if necessary
- . Check unloader and thermal dump for leaks

THREE MONTHLY REGULAR SERVICE

All professional machines need to be thoroughly serviced every three months.

- . Change pump oil
- . Check filter for foreign debris
- . Check unloader and thermal dump for leaks
- . Check all HP components for leaks: Gun/lance, HP hose and all fittings

SIX MONTHLY REGULAR SERVICE

To maintain the Bertolini pump warranty (four years from date of purchase), the pump must be serviced by an authorised service agent every six months. Contact Aussie for your nearest agent.

LOOK AFTER YOUR MACHINE AND IT WILL LOOK AFTER YOU!

Aussie HP Accessories ... making light work of cleaning chores



Aussie Spinner ...
CLEAN FLAT SURFACES FAST

stock code:
AGPDFSC20

Aussie Gritblast kit ...
remove paint & rust with ease



MORE BITE

Aussie Tele-wand ...
extend your reach to 5.5m



ideal for
reaching eaves &
washing windows

REACH FURTHER

stock code:
AGPDLTG18

includes **FREE**
harness kit

Aussie Turbomaster turbo lance ...
increase the effective working pressure of
your blaster without loading the pump



MORE PUNCH

WEAR PROTECTIVE GOGGLES & CLOTHING!



Australian Pump Industries Pty Ltd

7 Gladstone Road, Castle Hill NSW 2154

Ph: (02) 8865 3500 Fax: (02) 9894 4240

www.aussiepumps.com.au info@aussiepumps.com.au