

Wireless Rain-Click™ Sensor

OWNER'S MANUAL

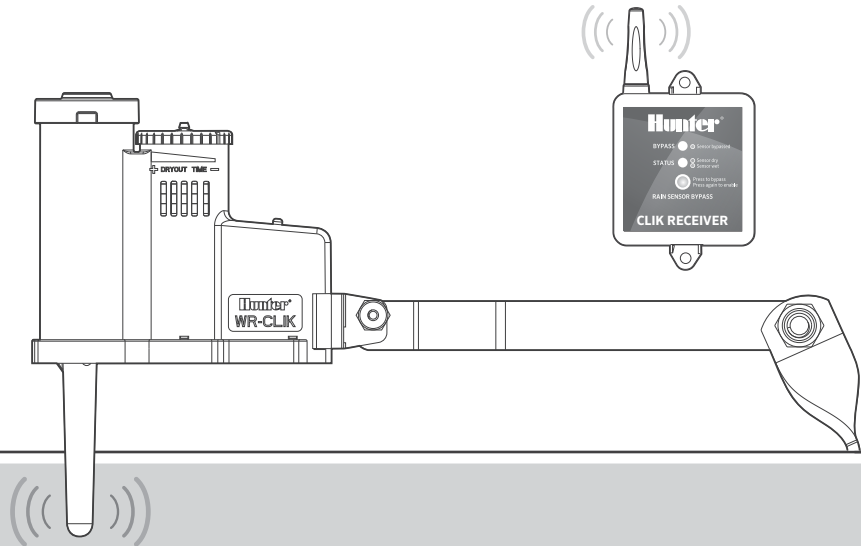

For use with WR-CLIK Rain Sensor

Hunter®

Table of Contents

3 Wireless Rain-Clik Features

3 Key Benefits

4 Wireless Rain-Clik Components

4 Wireless Rain-Clik Sensor

5 Wireless Receiver

6 Mounting the Receiver

6 Wiring the Receiver to Hunter Controllers

7 Wiring the Receiver to Other Controllers: Normally Closed Sensor Applications

7 Wiring the Receiver to Other Controllers: Normally Open Sensor Applications

8 Surface Mounting

8 Gutter Mounting

9 Adjustments and Operation

9 Tips for Mounting the Sensor

9 Receiver Operation

10 Bypassing the Sensor

10 Setting the Transmitter Address at the Receiver

11 Battery Life

11 Checking the Status of the Battery in the Transmitter

11 System Will Not Turn On at All

11 System Will Not Shut Off Even After Heavy Rainfall

11 Sensor Bypass LED Is Flashing Red

12 Replacement Parts and User-Installed Options

13 Notices

13 FCC Notice

14 Innovation, Science and Economic Development Canada (ISED) Compliance Notice

14 CE

15 Notes

Scan for helpful tips on installation, controller programming, and more.



hunter.info/RainClik

To prevent water waste, built-in Quick Response™ Technology instantly shuts down irrigation as soon as it starts raining.

Key Benefits

1. **Quick Response:** Innovative technology that turns off the irrigation system immediately rather than after it has accumulated a fixed amount of rain. No calibration is required.
2. **Maintenance-Free Design:** Provides trouble-free operation for at least 5 years. There are no batteries to replace.
3. **Wireless Operation Up to 243 m:** No wires are required between the rain sensor and controller.
4. **Wireless Rain-Clik Sensor (WR-CLIK):** Acts as a switch to deactivate automatic watering of your irrigation controller when it rains. Once rain has stopped and the sensor has dried out, automatic irrigation will resume. The sensor also halts irrigation when temperatures drop to 3°C or below. The system will resume normal operation once temperatures increase.
5. **Automatic Synchronization:** The Wireless Rain-Clik transmitter will send wireless signals every hour to the receiver to ensure that the sensor and receiver are continuously synchronised.
6. **Lost Communication/Battery Status Indication:** The Sensor Bypass LED will flash RED if the receiver has not received a signal from the transmitter. This can indicate a low or dead battery.

Wireless Rain-Clik Sensor

1. **Manual Test Spindle:** Press and hold the manual test spindle to confirm proper operation of your transmitter.
2. **Vent Ring:** Used to adjust the reset rate or dry out time for the sensors. Opening the vents will decrease the reset rate, while closing the vents will increase the time it takes for the discs to dry out.
3. **Radio Antenna:** Transmits a wireless signal to the receiver up to 243 m. The antenna should be oriented vertically.
4. **Mounting Arm:** Metal extension arm for mounting the sensor.
5. **Battery Status LED:** Used to determine the status of the sealed battery. Pushing the manual test spindle will flash the LED light, indicating that the battery is good.

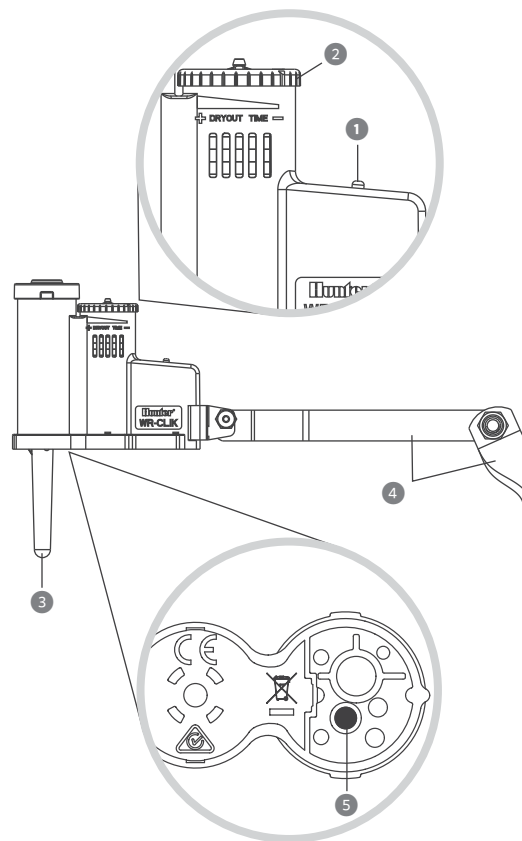

Wireless Receiver

1. **Bypass Button:** Allows automatic or manual watering when the sensor is active.
2. **Receiver Status LED:** Used to indicate the status of the sensor.
3. **Receiver Bypass LED:** Indicates when sensor has been bypassed.
4. **Radio Antenna:** Receives a wireless signal from the transmitter up to 243 m line-of-sight. The antenna should be oriented vertically.
5. **AC Power Wires:** The two yellow wires are attached to a 24 VAC source from the controller.
6. **Receiver Wires:** The sensor wires are attached to either the sensor terminals in the controller or in-line with the valve common wire.
 - **Blue/White Wires:** Used for normally closed sensor applications (Hunter controllers).
 - **Blue/Orange Wires:** Used for normally open sensor applications.
7. **Rubber Cover:** Used to protect the receiver when mounted in outdoor locations.

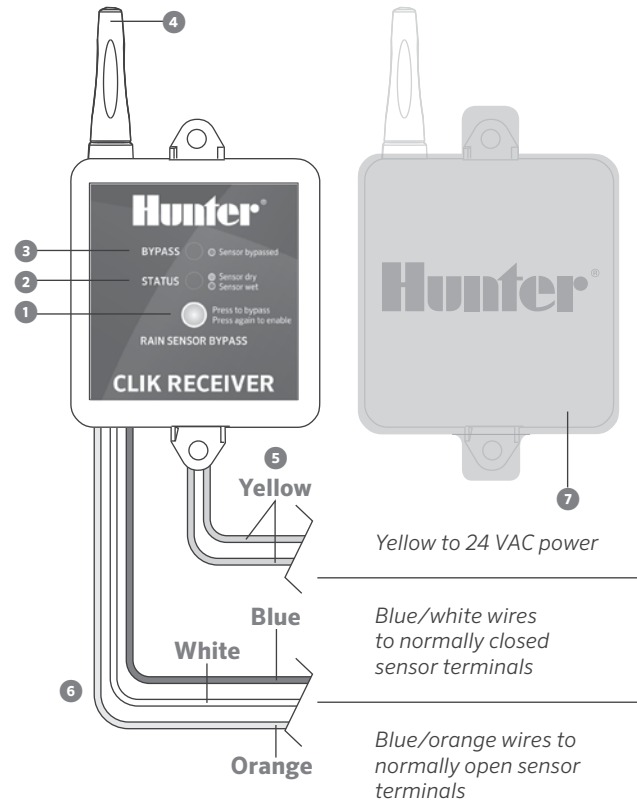

Wiring the Receiver to Hunter Controllers

1. Remove the sensor jumper across the two SEN terminals in the controller.
2. Attach the two yellow wires to the 24 VAC terminals.
3. Attach the blue wire to one SEN terminal and the white wire to the other SEN or SEN COM terminal.



Note:

Additional setup steps required for Hydrawise™, ACC, and ACC2 Controllers.

- **Hydrawise Controllers:** Complete the installation by configuring the sensor in your Hydrawise account.
- **ACC Controllers:** Use features at the “Set Sensor Operation” dial position on ACC to complete setup.
- **ACC2 Controllers:** Use “Devices and Sensor Response” options on ACC2 to complete setup.



SCAN
for help



hunter.help/HydrawiseSensor

hunter.help/ACC2Sensor

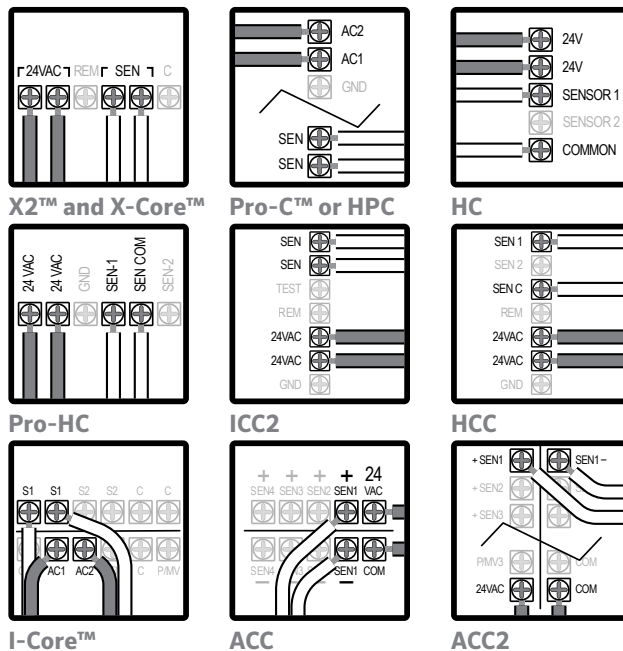

Wiring the Receiver to Other Controllers: Normally Closed Sensor Applications

1. Attach the two yellow wires to the 24 VAC terminals.
2. Attach the blue and white wires to the sensor terminals (if available) or in-line with the valve common wire.

Wiring the Receiver to Other Controllers: Normally Open Sensor Applications

1. Attach the two yellow wires to the 24 VAC terminals.
2. Attach the blue and orange wires to the sensor input.

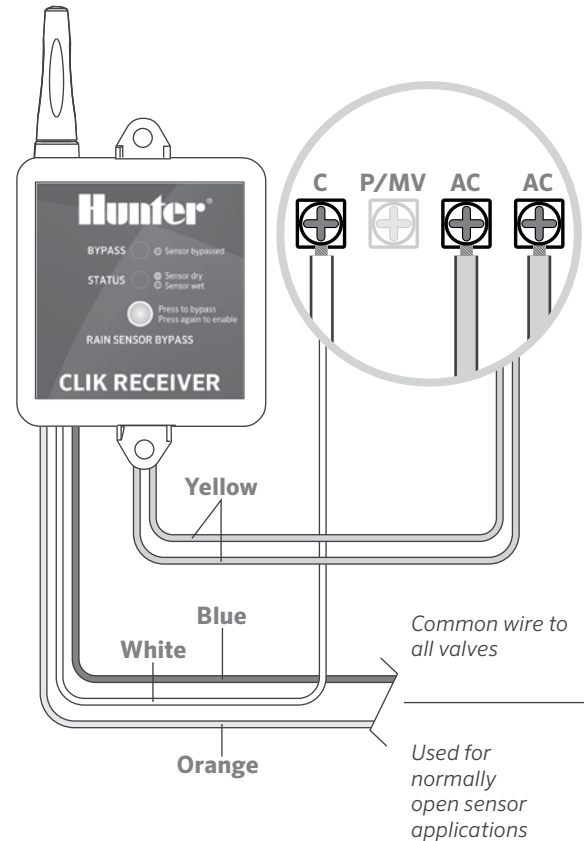

Mounting the Sensor

Surface Mounting

Using the screws provided with your sensor, mount the transmitter on any surface where it will be exposed to unobstructed rainfall, but not in the path of sprinkler spray. The sensor should be oriented upright (as pictured), but the swivel bracket can be moved for mounting on any angled surface. Loosen the locknut and screw before swivelling the bracket, and then retighten.

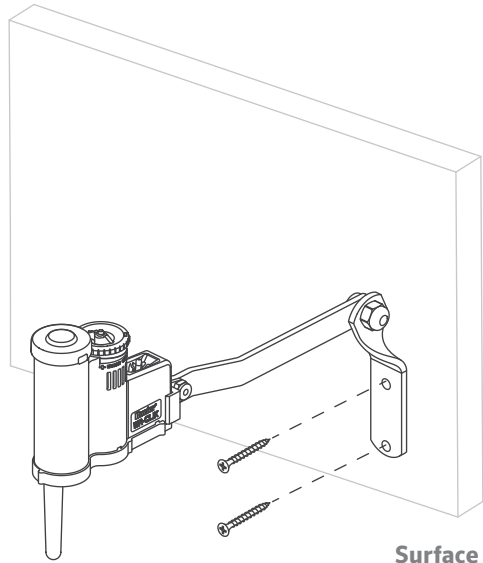

Gutter Mounting

The Sensor Gutter Mount (SGM) allows the transmitter to be mounted directly to the edge of a gutter. Install the SGM on the transmitter by removing the metal extension arm supplied with your sensor and reinstalling the SGM. Position the gutter mount on the edge of the gutter and twist the thumbscrew to secure it in place.

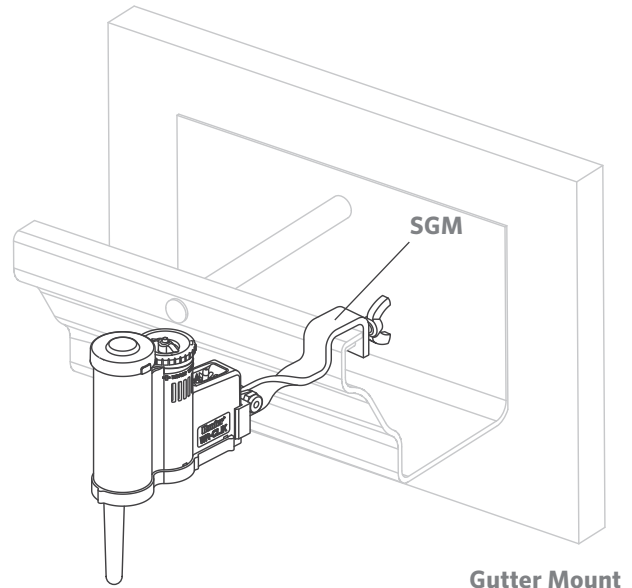

Tips for Mounting the Sensor

- Choose a location, such as the side of a building or post. The closer the transmitter is to the receiver, the better the reception. Do not exceed 243 m.
- To ensure maximum range in communication, mount the receiver and transmitter away from sources of electrical interference (e.g., control panels, transformers, etc.) or metal objects. Best performance is obtained when no physical obstruction lies between the transmitter and receiver.
- Correct placement of the Wireless Rain-Clík model is important for accurate temperature sensing. The best location is out of direct sunlight.
- The reset rate refers to the amount of time it takes the sensor to dry out and resume its normal operation. The mounting location will affect this rate. For example, mounting the transmitter in a very sunny location may cause the sensor to dry out more quickly than desired. Similarly, mounting the sensor in constant shade may keep the sensor from drying out sooner.

Receiver Operation

The receiver has two LED lights that indicate the state of the system.

1. SENSOR STATUS LED:

RED – Sensor is wet (watering disabled).

GREEN – Sensor is dry (watering enabled).

YELLOW – Sensor is in addressing mode.

2. SENSOR BYPASS LED:

RED – Rain sensor is bypassed (even though the sensor is bypassed, the STATUS LED will continue to alert you of the state of the sensor — wet or dry).

OFF – Rain sensor is enabled.

FLASHING RED – Indicates that communication between the transmitter and receiver was lost.



Note

When you first apply power to the receiver, the SENSOR STATUS LED will be RED. Press the manual test spindle on the transmitter for five seconds and release the spindle. The SENSOR STATUS LED will turn GREEN, indicating proper operation.

Bypassing the Sensor

The sensor can be bypassed by using the built-in bypass feature on the receiver. To bypass the sensor, press the SENSOR BYPASS button on the receiver. The bypass status light will turn red when the sensor is bypassed. Pressing the SENSOR BYPASS button again will re-enable the sensor and the sensor bypass light will go out.

Setting the Transmitter Address at the Receiver

Each transmitter is produced with a unique address. A receiver must learn this address to work with that transmitter. This step is only necessary if transmitters and receivers are purchased separately.

1. Prior to applying power (yellow wires) to the receiver, press and hold the bypass button on the receiver.
2. While the bypass button is depressed, apply power to the receiver. The sensor status indicator light should light up yellow, indicating that the receiver is ready to learn a new address.
3. Press and hold the quick response button on the transmitter.
4. Within four seconds, the receiver's sensor status indicator light should turn red. The receiver has now learned the address, which will be retained even in the event of a power outage.
5. Release the button on the transmitter. The sensor status indicator light should turn green.

Note

Units purchased as a kit will already have their communication address preset. No addressing is necessary. However, if the receiver or transmitter is replaced, you will need to reset the address.

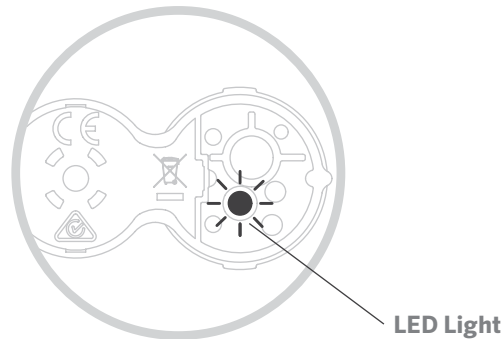

Battery Life

The Wireless Rain-Clik Transmitter is designed to operate for at least 5 years with its sealed, maintenance-free battery. The transmitter is available as a replacement part (WR-CLIK-TR). Should you need to change the transmitter, the receiver will have to learn the new transmitter address.

Checking the Status of the Battery in the Transmitter

1. Press and hold the quick response spindle at the top of the sensor on the short stack.
2. Within a few seconds the LED light on the bottom of the sensor will briefly flash.
3. Release the spindle and the LED light will flash again. If the LED flashes, the battery in the transmitter is good.



SCAN
for help



hunter.help/WRCLIK

If you are experiencing problems with your Wireless Rain-Clik Sensor, follow these simple checks first before assuming the unit is defective and replacing it.

System Will Not Turn On at All

- Check to make sure that the sensor discs are dry and the switch “clicks” on and off freely by pressing the top of the spindle.
- Look for breaks in the wire leading to the receiver and check all connections.
- Verify outside air temperature.

System Will Not Shut Off Even After Heavy Rainfall

- Remove the sensor jumper across the two SEN terminals.
- Check to make sure that rainfall is hitting the sensor.
- Look for breaks in the wire leading to the receiver and check all connections.
- Check the battery in the transmitter.

Sensor Bypass LED Is Flashing Red

- Make sure the battery in the transmitter is good.
- Check for obstructions around the transmitter or receiver antenna.

Replacement Parts and User-Installed Options

REPLACEMENT PARTS

Part Number	Description
WR-CLIK-TR	Wireless Rain-Clik Transmitter Assembly
505900SP	Cap and Spindle Assembly
439700	Mounting Bracket
SGM	Sensor Gutter Mount
WR-CLIK-R	Receiver Assembly

USER-INSTALLED OPTIONS

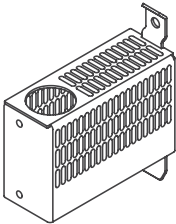
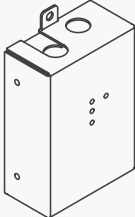
Part Number	Description
WS-GUARD	 <p>Vandal-resistant Wireless Sensor Guard for flat surfaces or pole mounting (order sensor separately)</p>
WR-GUARD	 <p>Vandal-resistant Wireless Receiver Guard for pedestal mounting (order receiver separately)</p>

FCC Notice

This device complies with part 15 of the FCC Rules. Operation is subject to the following two conditions: (1) This device may not cause harmful interference, and (2) this device must accept any interference received, including interference that may cause undesired operation.

This equipment has been tested and found to comply with the limits for a Class B digital device pursuant to Part 15 of the FCC Rules. These limits are designed to provide reasonable protection against harmful interference in a residential installation. This equipment generates, uses, and can radiate radio frequency energy and, if not installed and used in accordance with the instructions, may cause harmful interference to radio communications. However, there is no guarantee that interference will not occur in a particular installation. If this equipment does cause harmful interference to radio or television reception, which can be determined by

turning the equipment off and on, you are encouraged to try to correct the interference by taking one or more of the following measures:

- Reorient or relocate the receiving antenna.
- Increase the separation between the equipment and receiver.
- Connect the equipment into an outlet on a circuit different from that of which the receiver is connected.
- Consult the dealer or an experienced radio/TV technician for help.

Changes or modifications not expressly approved by Hunter Industries could void the user's authority to operate this device. If necessary, consult a representative of Hunter Industries Inc. or an experienced radio/television technician for additional suggestions.

Innovation, Science and Economic Development Canada (ISED) Compliance Notice

This device contains licence-exempt transmitter(s)/ receiver(s) that comply with Innovation, Science and Economic Development Canada's licence-exempt RSS(s). Operation is subject to the following two conditions:

1. This device may not cause interference.
2. This device must accept any interference, including interference that may cause undesired operation of the device.

Le présent appareil est conforme aux CNR d'Industrie Canada applicables aux appareils radio exempts de licence. L'exploitation est autorisée aux deux conditions suivantes:

1. L'appareil ne doit pas produire de brouillage, et
2. L'utilisateur de l'appareil doit accepter tout brouillage radioélectrique subi, même si le brouillage est susceptible d'en compromettre le fonctionnement.

MAXIMUM OUTPUT POWER

Frequency Band (MHz)	Maximum Power (mW)
433.05 - 434.790	0.1

CE

Hereby, Hunter Industries declares that the radio equipment type models WR-CLIK are in compliance with Directive 2014/53/EU.

The full text of the EU declaration of conformity is available at the following internet address:
<http://subsite.hunterindustries.com/compliance>



hunter.info/Compliance

Helping our customers succeed is what drives us. While our passion for innovation and engineering is built into everything we do, it is our commitment to exceptional support that we hope will keep you in the Hunter family of customers for years to come.



**Gene Smith, President,
Landscape Irrigation and Outdoor Lighting**

HUNTER INDUSTRIES | *Built on Innovation*®
1940 Diamond Street, San Marcos, CA 92078 USA
hunterindustries.com

© 2022 Hunter Industries™. Hunter, the Hunter logo, and all other trademarks are property of Hunter Industries, registered in the U.S. and other countries.

P/N 715182 23-594 | EM 10/22

[|For more information visit TheLandscapeStore.com.au](http://TheLandscapeStore.com.au) | (02) 9161 3939 |