

# 2029-3SPB-75IN-SAC-1STRNG4TR

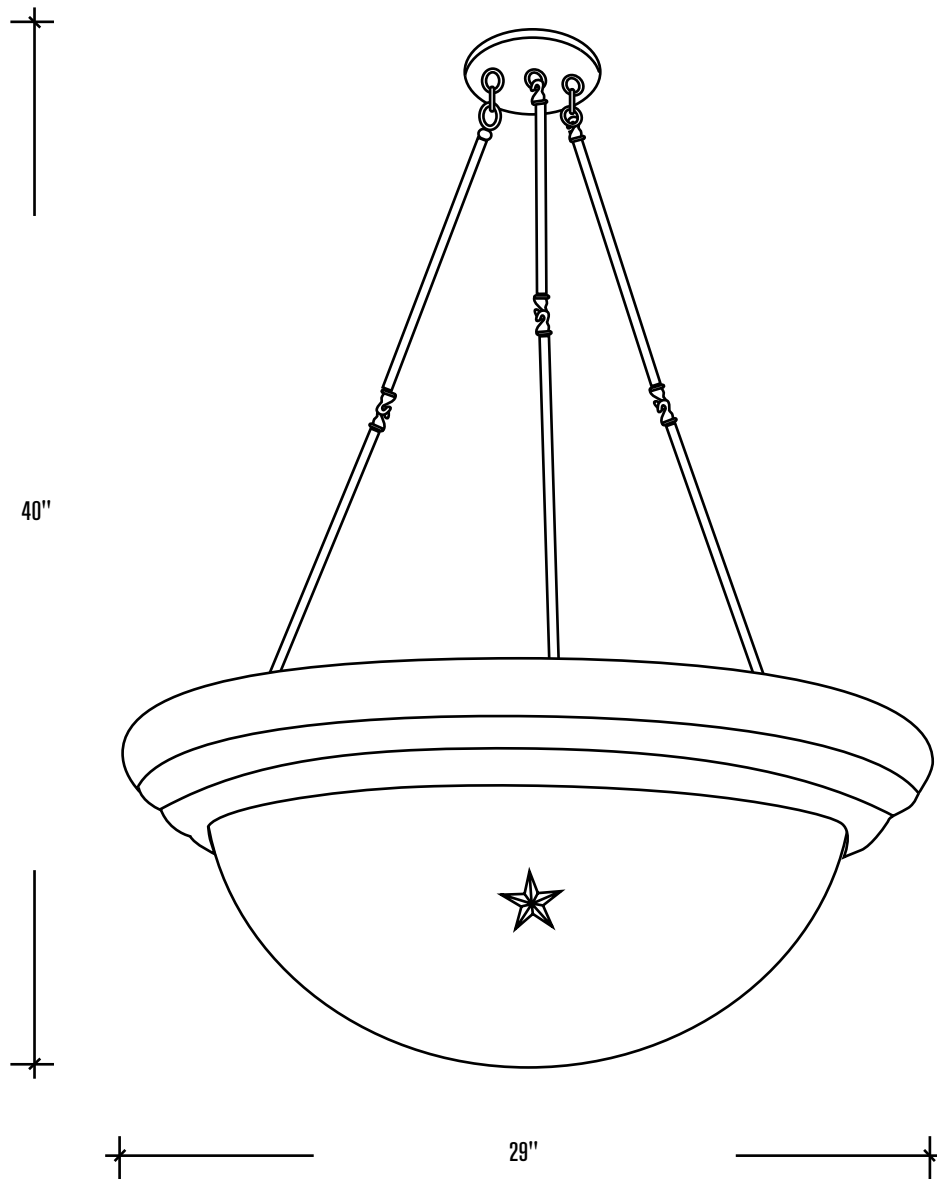

**Lamping:** 3-75W Incandescent, 120V  
**Finish:** Solid Polish Brass  
**Description:** 29" Diameter Ring with Sandblasted White Acrylic Dome, 4 Tier Rod, 1 Center Stem with 4 Decorative Stars

**Dry Location**



532 West Windsor Road  
 Glendale, CA. 91204

[www.dlights.com](http://www.dlights.com)

Date: 04-25-05

Drawn by: CL

Tel: 818.956.5656 • 800.414.5109 • Fax: 818.956.5657