

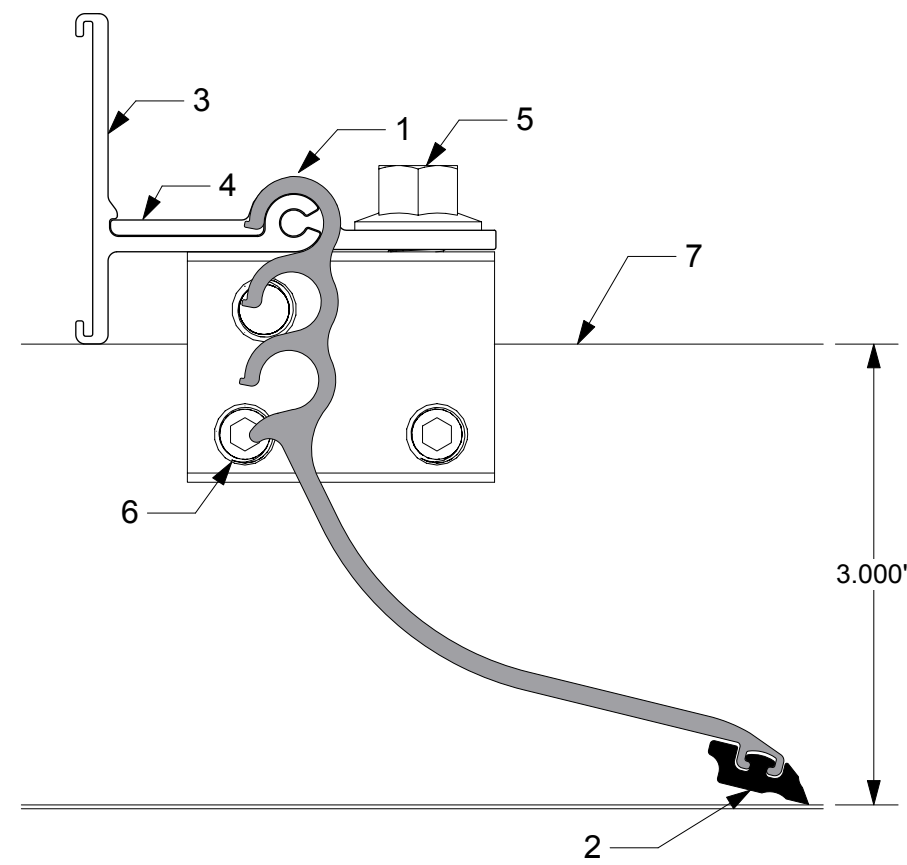

USE SLIDING SNOCLIP III FOR STANDING SEAMS  $\geq 1.75"$  &  $\leq 3"$

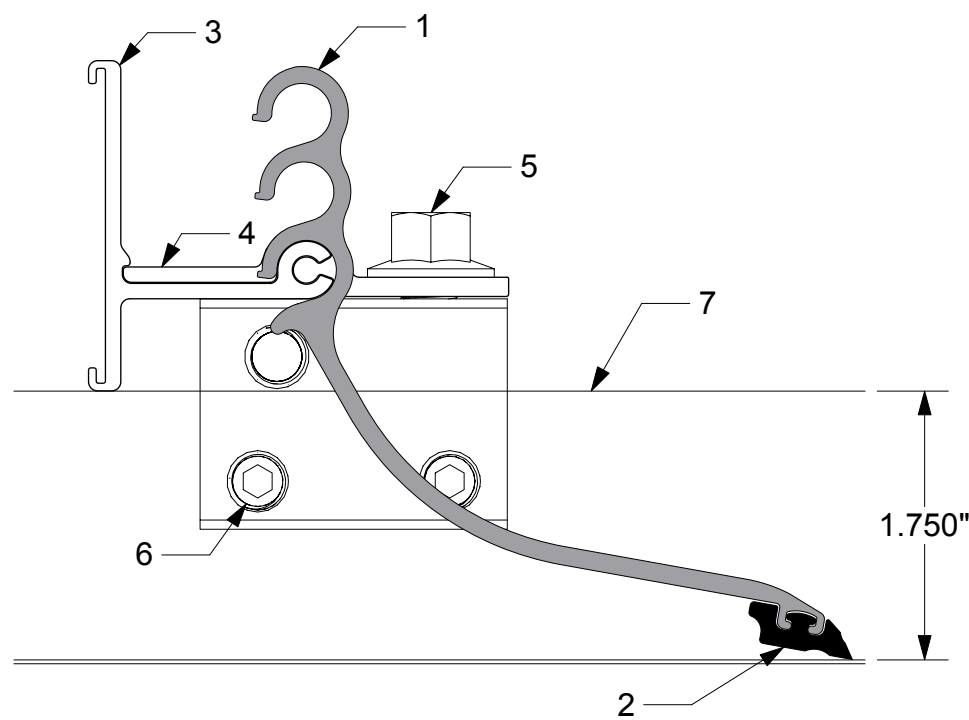

1. SLIDE THE SNOCLIP ON TO COLORGARD FROM END

2. ROTATE THE SNOCLIP DOWN

3. THE "TOE" OF A PROPERLY INSTALLED SNOCLIP™ WILL ENGAGE THE PANEL BEFORE THE "HEEL" DOES.

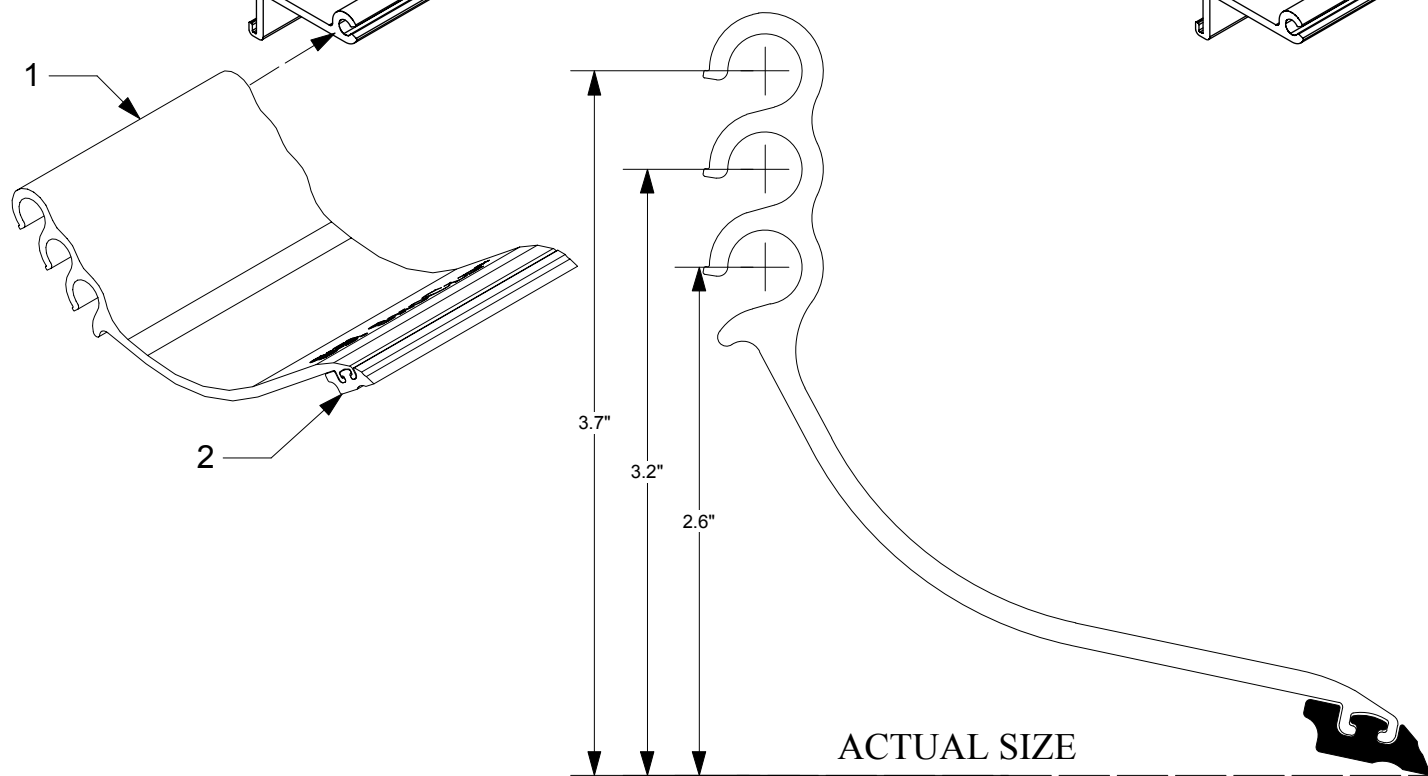
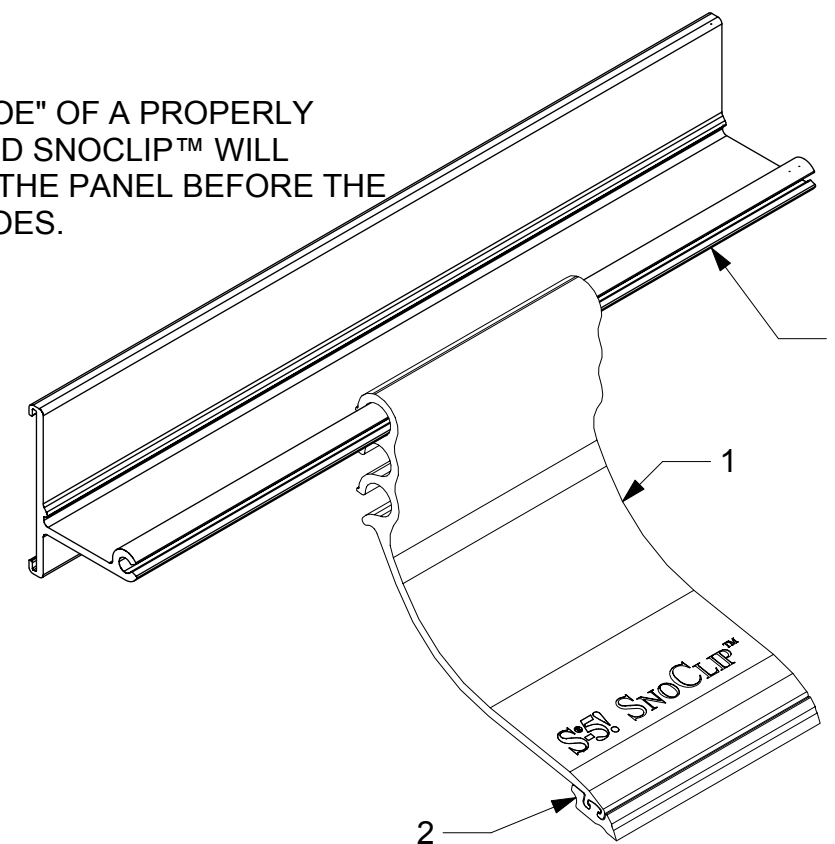
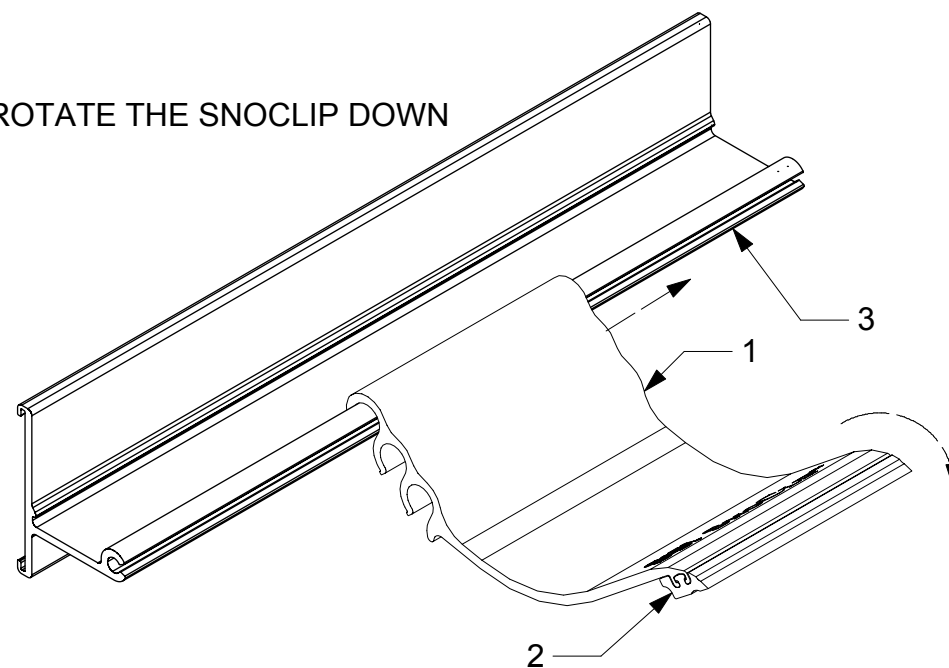
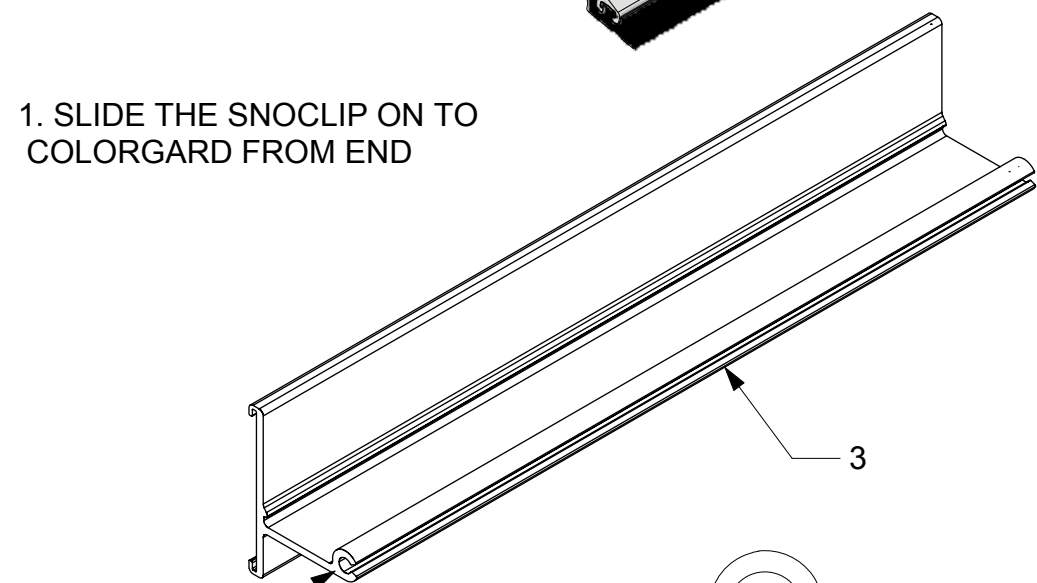

**Notes**

- 1. SNOCLIP
- 2. RUBBER FOOT
- 3. COLORGARD CROSSMEMBER
- 4. VERSACLIP
- 5. M10 HEX FLANGE BOLT
- 6. ROUND POINT SETSCREW
- 7. TOP OF THE SEAM

|  |                       |   |                    |
|--|-----------------------|---|--------------------|
| MATERIAL:  | <b>6000 SERIES AL</b> |   |                    |
| EST ASSEMBLY WEIGHT :  |                       |   |                    |
| SUPPLIED HARDWARE:   |                       |   |                    |
| SCALE:   | <b>NTS</b>            |   |                    |
| OTHER:   |                       |   |                    |
|   |                       | METAL ROOF INNOVATIONS, LTD.<br>8655 TABLE BUTTE RD<br>COLORADO SPRINGS, CO 80908<br>719-495-0518<br>719-495-0045 (FAX) |                    |
|  |                       | TITLE <b>SLIDING SNOCLIP III</b>  |                    |
| DRAWING NO.  | SSC3-A-0-A [CCD]      | DRAWN BY  | MS DATE 08/09/2013 |
| S-5!® PRODUCTS ARE PROTECTED BY MULTIPLE U.S. PATENTS INCLUDING 5,228,248, 5,983,588 AND 6,164,033 (OTHERS ISSUED AND PENDING). EUROPEAN PATENTS ARE ALSO APPLIED FOR AND PENDING UNDER THE PATENT COOPERATION TREATY WITH DIVISIONAL FILING RIGHTS RETAINED. METAL ROOF INNOVATIONS, LTD. (LICENSOR OF S-5!® TECHNOLOGY) AGGRESSIVELY PROSECUTES PATENT INFRINGEMENT. |                       |   |                    |