

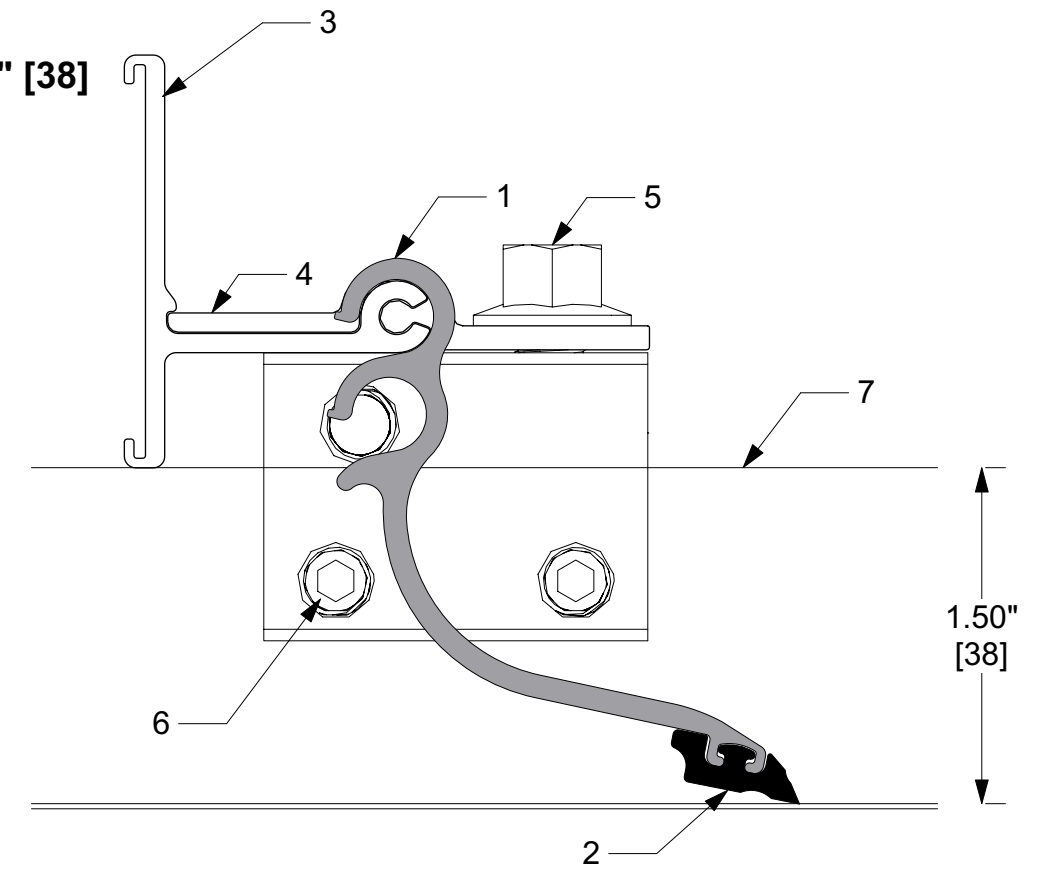

USE SLIDING SNOCLIP II FOR STANDING SEAMS $\geq 1"$ [25] & $\leq 1.50"$ [38]

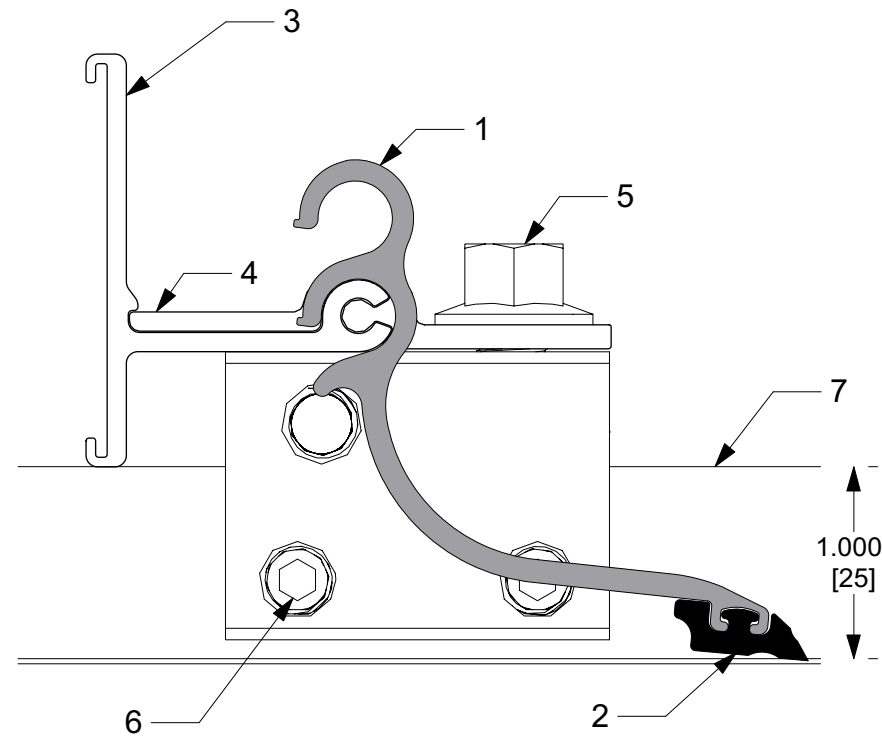

1. SLIDE THE SNOCLIP ON TO COLORGARD FROM END

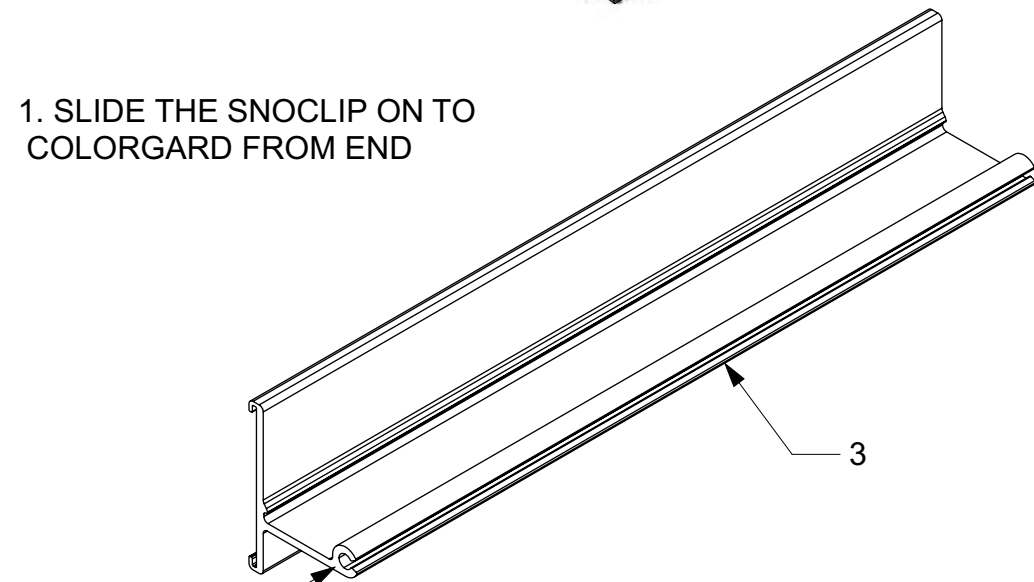

2. ROTATE THE SNOCLIP DOWN

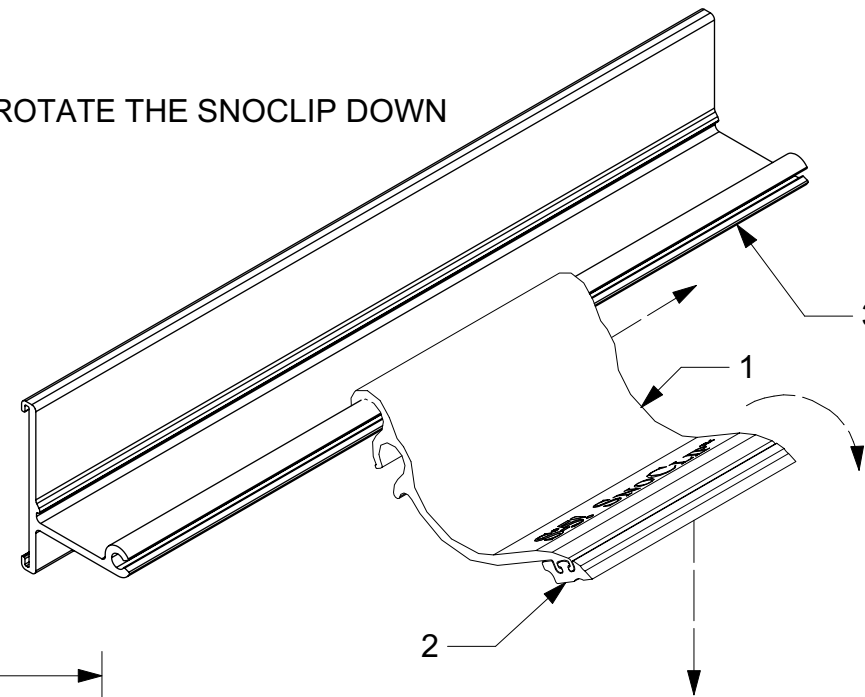

3. THE "TOE" OF A PROPERLY INSTALLED SNOCLIP™ WILL ENGAGE THE PANEL BEFORE THE "HEEL" DOES.

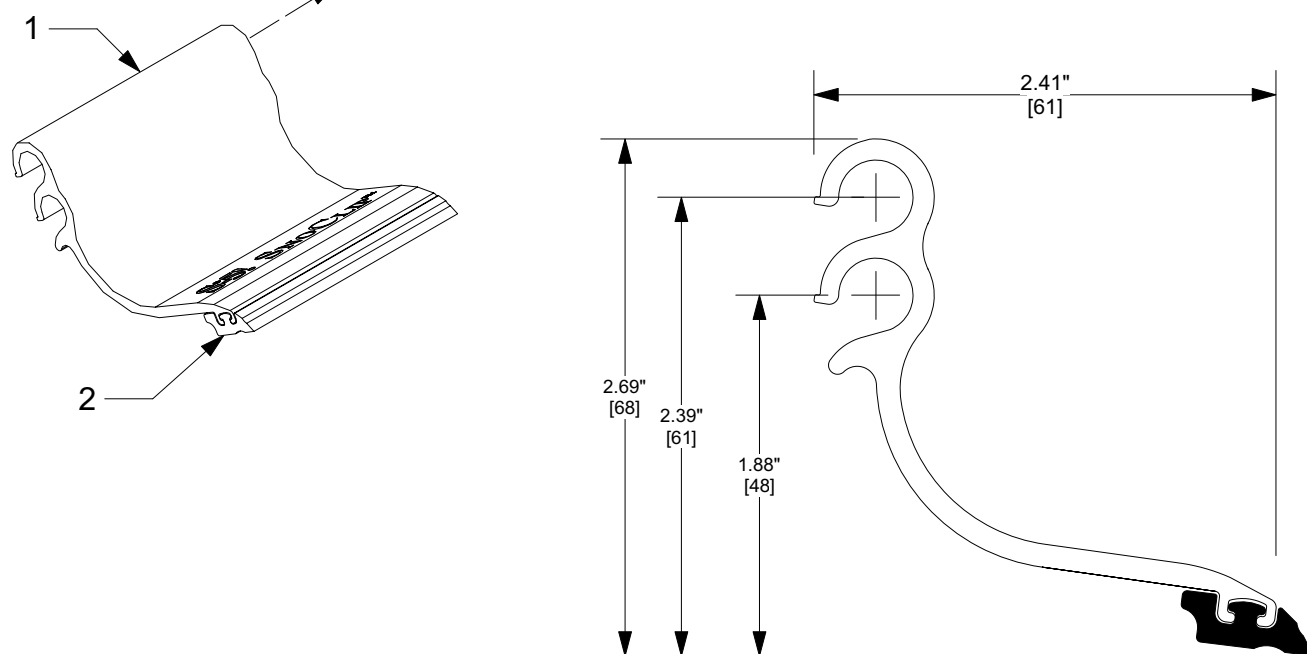
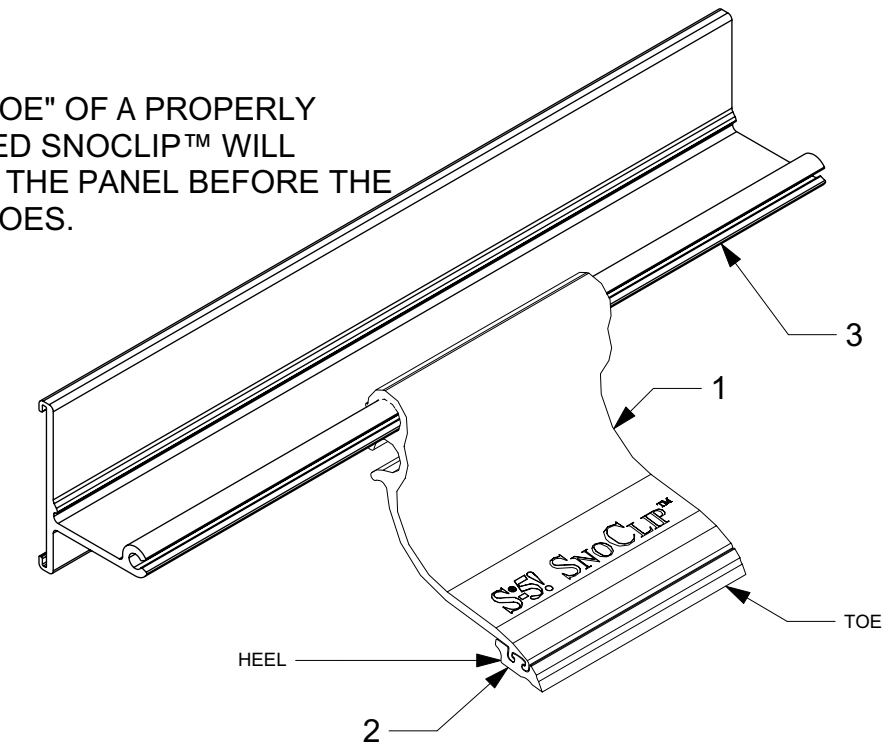

ACTUAL SIZE

Notes

1. SNOCLIP
2. RUBBER FOOT
3. COLORGARD CROSSMEMBER
4. VERSACLIP
5. M10 HEX FLANGE BOLT
6. ROUND POINT SETSCREW
7. TOP OF THE SEAM

MATERIAL: 6000 SERIES AL	 METAL ROOF INNOVATIONS, LTD. 8655 TABLE BUTTE RD COLORADO SPRINGS, CO 80908 719-495-0518 719-495-0045 (FAX)		
EST ASSEMBLY WEIGHT :			
SUPPLIED HARDWARE:	TITLE SLIDING SNOCLIP II		
SCALE: NTS	DRAWING NO. SSC7-A-0-A CCD	DRAWN BY MS	DATE 08/08/2013
OTHER:	<small>S-5!® PRODUCTS ARE PROTECTED BY MULTIPLE U.S. PATENTS INCLUDING 5,228,248, 5,983,588 AND 6,164,033 (OTHERS ISSUED AND PENDING). EUROPEAN PATENTS ARE ALSO APPLIED FOR AND PENDING UNDER THE PATENT COOPERATION TREATY WITH DIVISIONAL FILING RIGHTS RETAINED. METAL ROOF INNOVATIONS, LTD. (LICENSOR OF S-5!® TECHNOLOGY) AGGRESSIVELY PROSECUTES PATENT INFRINGEMENT.</small>		