

XSERIES

MALTA DYNAMICS MOBILE GRABBER

SPEC SHEET

X1260

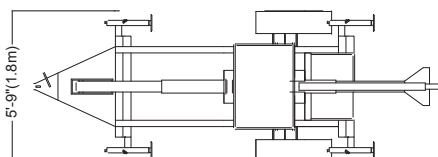
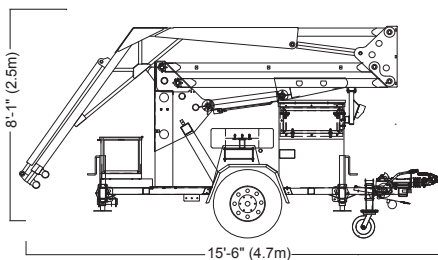
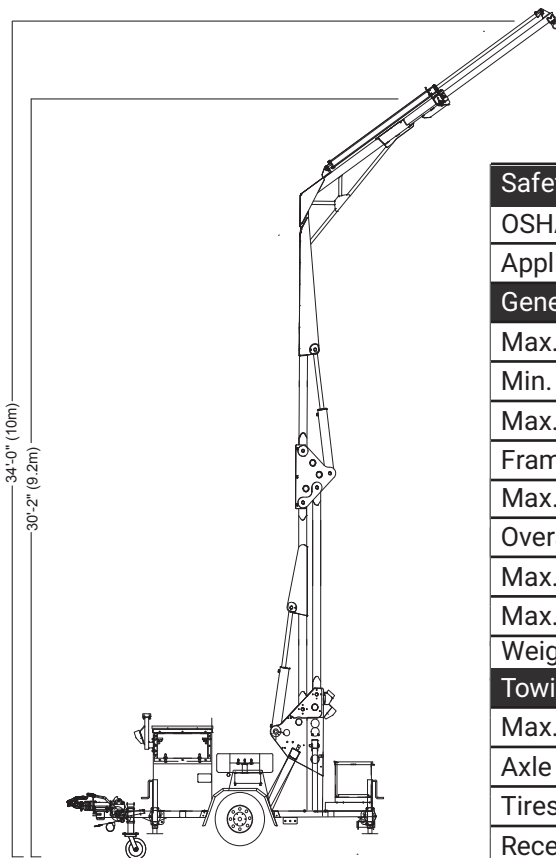

Safety Standards	
OSHA Fall Arrest Standards	
Applicable Fall Arrest Standards set forth in ANSI Z359.6	
General	
Max. Working Height	34' (10.4m) with Mast Fully Extended
Min. Working Height	2' (.6m)
Max. Folded Height	8'-1" (2.6m)
Frame Width	5'-9" (1.7m)
Max. Arm Reach Out	9'-9.5" (3m)
Overall Length	15'-6" (4.7m)
Max. Anchor Point capacity	310 lbs
Max. Allowable Users	5
Weight	5940 lbs (2694 kg)
Towing	
Max. Towing Speed	Posted Highway Speed
Axle	7000 lbs. Torsion Axle w/Electric Brakes
Tires	225/70/R15 Radials
Receiver	2-5/16" Ball
Trailer Plug Wiring	7-Pole Blade Style lead
Operation	
Actuating Method	Electric-driven Hydraulic system
Controls	Remote (15 ft. cord length)
Power Source	12 volt Battery (210 Amp hour rating) w/30A Fuse & Battery Gauge
Charging System	110 Volt quick Smart Charger with Cord
Outri gger System	Four (4) Manually Adjustable Jacks
Hydraulics	
Fluid Type	Mobil DT10 Excel 22
Fluid Capacity	12.5 Gallons

*SRLs not included.