

LG Electronics, Home appliance & Air solution company

56, Digital-ro 10-gil, Geumcheon-gu, Seoul, Republic of Korea (153-801)

www.lg.com

www.lgeaircon.com

LG HVAC SOLUTION

WATER COOLED SCREW CHILLER

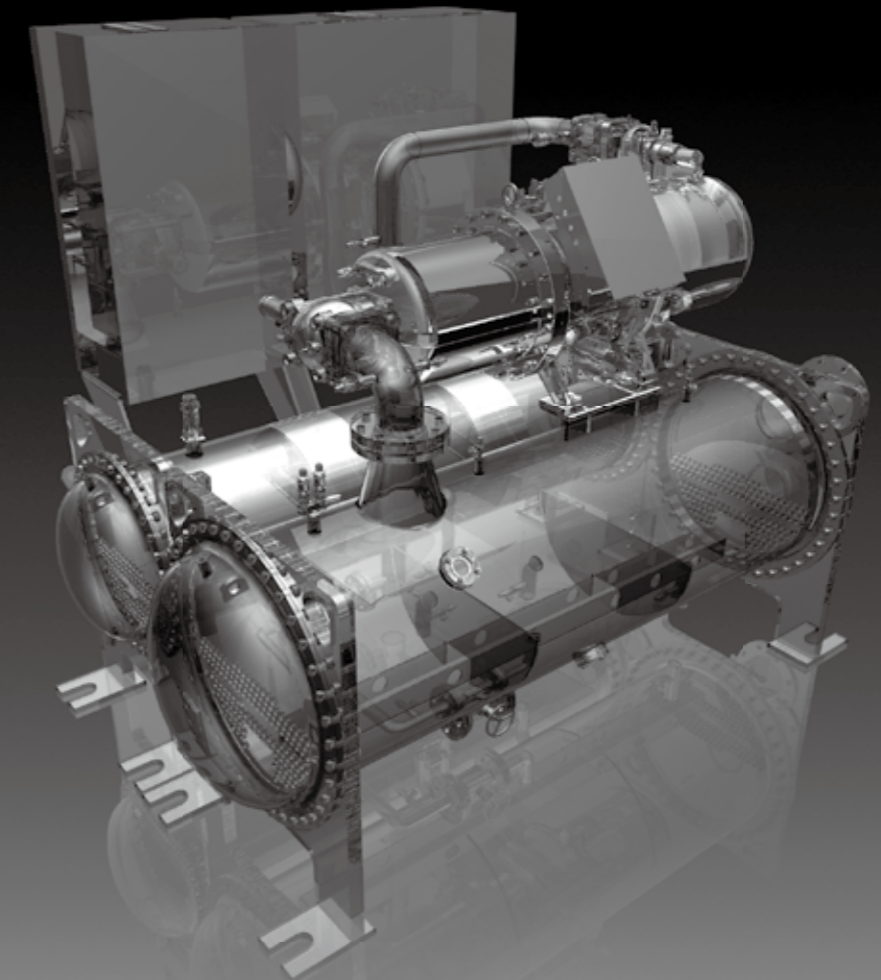

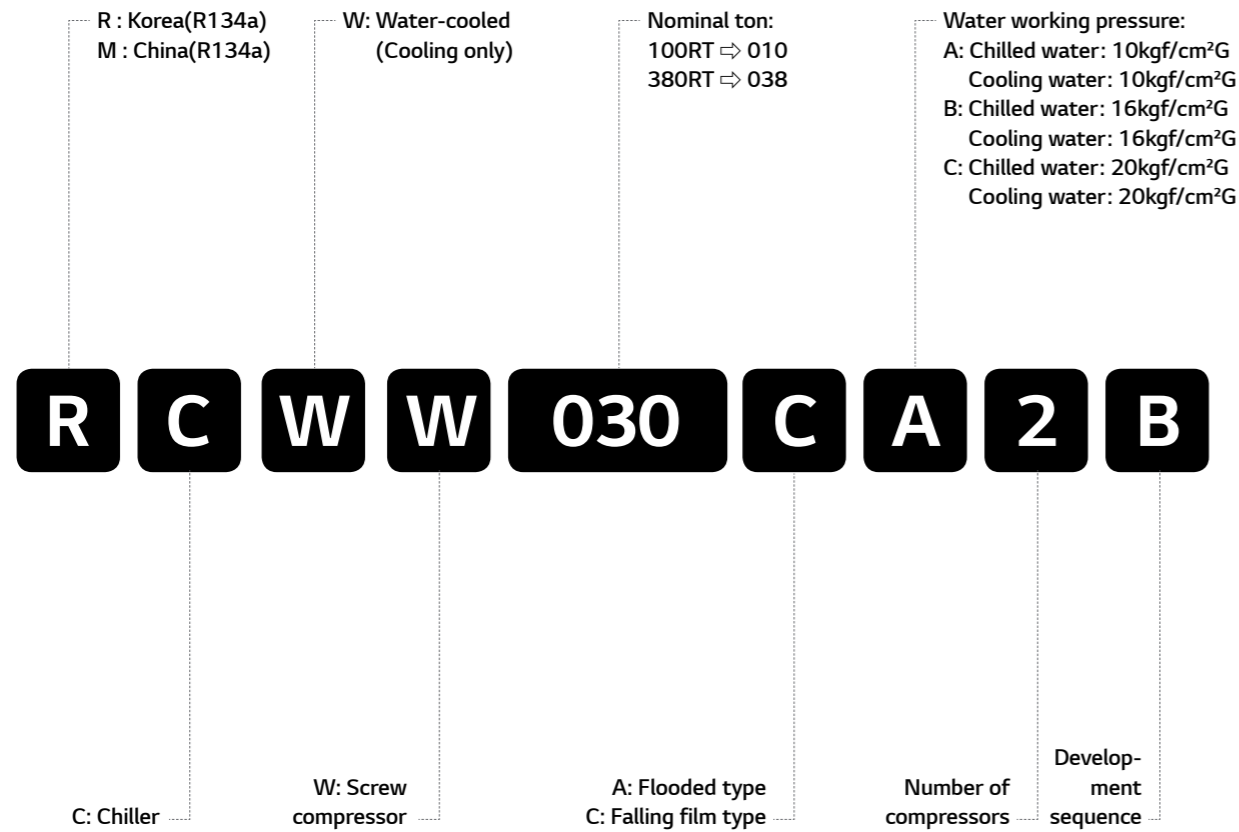

Contents

- 02 Nomenclature
- 03 Line up & Introduction
- 04 Equipment overview
- 06 Control
- 08 Accessories and options
- 09 Specification
- 15 Electrical data
- 22 Outline drawing
- 24 Foundation
- 26 Piping diagram
- 28 Control wiring
- 30 Power wiring
- 32 Installation
- 34 Guide specification

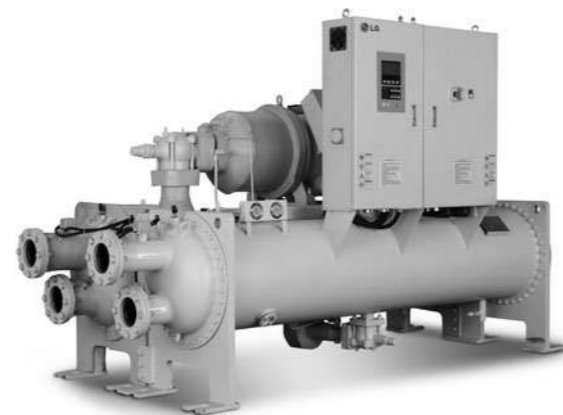

Line up

Model		50	100	150	200	250	300	350	400	450	500
	R-134a		75RT						380RT		
			75RT							440RT	

* The above range is based on the nominal tonnage.



LG's latest Water cooled screw chiller offers excellent operational efficiency thanks to the company's advanced technologies and unrivalled air conditioning expertise. The new model's advanced capacity control system valve help to improve performance and efficiency. LG's proprietary PID(Proportional, Integral, Differential control), which controls hydraulic-head loss rate, helps to minimize energy loss even further.

- High-performance compressor manufactured by specialized manufacturer is adopted to ensure that the chiller is economical and durable with low vibration and low noise.
- Highly integrated motherboard is adopted and hence the function is strong and reliable.
- Advanced control algorithm is adopted to control chiller in advance and hence avoid frequent stoppage protection of chiller.
- We have set complete safety protection function in order to make chiller safely and reliably run.
- The linkage control and remote monitoring function of peripheral equipment ensure that the chiller can run safely and the operation and monitoring are convenient.
- The selection of excellent raw materials and fittings is the key to guaranteeing chiller quality.

High efficiency, High reliability

The RCWW & MCWW series is a kind of water-cooled spray screw chiller produced by LGE Corporation. Because of the special structure design, the chiller has high efficiency and high reliability.

Optimized dedicated motor R134a with high efficiency

Made of premium grade, low-loss core steel with the special slot design, the motors of R134a dedicated compressors

can gain the highest efficiency with low power consumption. Besides, different winding for specific voltage and frequency requirement contributes to the best power factor and excellent performance.

Constructional design of dedicated screw compressor

The screw compressor is characterized by a very compact design. Most of inner dimensions have been totally modified considering displacement volume, size of compression chamber, length & profile of rotors, oil separator specification and oil piping rearrangement, etc. to ensure consistency and cost effectiveness of the compressor.

Compressor

- Semi-hermetical twin-rotor screw compressor.
- Direct-drive, low speed/RPM for high efficiency and high reliability.
- Only three moving parts, resulting in high reliability with simple solution.
- Field serviceable compressor and easy maintenance.
- Precise rotor tip clearance.
- The world's advanced patent screw tooth with low noise, smooth operation long life advantages.
- A refrigerant dispersing cooling device is set internally for compressor cooling, which uses return-refrigerant cooling.
- Years of research and testing. The LG screw chiller has amassed thousands of hours of testing, and conditions

beyond normal air conditioning applications.

Unit performance testing

LG began promoting factory performance tests for air-cooled chillers and water-cooled chillers, to show we stand behind the products we design and build.

The benefits of a performance test include verification of performance, prevention of operational problems, and assurance of a smooth start-up.

Only a performance test conducted in a laboratory or laboratory grade facility will confirm both performance and operation of a specific chiller.

Mostly factory performance tests go smoothly. If a problem occurs, LG personnel easily correct them and chiller is shipped to job site.

When a factory performance test is requested, the test can be conducted at the specified, design conditions. The test facility has the capability to control ambient test conditions to assure our customers that our chillers will perform as predicted.

AHRI certification program and standards and codes

Chillers conform to the following Standards and Codes:

- AHRI 550/590 - water chilling packages using the vapor compression cycle.
- ANSI/ASHRAE 34 - number designation and safety classification of refrigerants.
- ASME Section VIII(Option) - boiler and pressure vessel.
- GB/T 18430.1 - water chilling(heat pump) packages using the vapor compression cycle - part 1: water chilling(heat pump) packages for industrial & commercial and similar applications. (This code is only applied to product manufactured in China)



Equipment Overview Semi-hermetic twin compressor

The semi-hermetic screw compressor is developed especially for applications in air-conditioning and refrigeration. With high operating load design, each compressor is of high efficiency and reliability in all operating conditions. Each compressor has the latest and advanced 5-to-6 Patented Screw Rotor Profile designed to ensure high capacity and efficiency in all operating conditions.

The compressor is equipped with separated radial and axial bearings, liquid injection and economizer connection, PTC motor temperature thermistors and discharge temperature thermistors, a motor protector, and oil level switch and

oil pressure differential switch and other accessories. The complete accessories and their new designs guarantee the compressor has the best reliability, longest bearing life during heavy duty running and strict operating conditions.

The slide valve for capacity control is located in the compressor chamber. The slide valve is actuated by injection of pressurized oil into the cylinder from the oil sump as well as bypass of oil through solenoid valves in each oil lines with pressure differential.

The screw compressors are equipped with either 3-step/4-step capacity control system or continuous(stepless) capacity control system. Both of the capacity control systems consist of a modulation slide valve, piston rod, cylinder, piston and piston rings. The slide valve and the piston are connected by a piston rod. The principle of operation is using the oil pressure to drive the piston in the cylinder. The lubrication oil flows from the oil sump through the oil filter cartridge and capillary then fills into the cylinder due to the positive oil pressure bigger than the right side of spring force plus the high pressure gas. The positive pressure differential causes the piston to move toward the right side in the cylinder. When the slide valve moves toward the right side, the effective compression volume in the compression chamber increases. This means the displacement of refrigerant gas also increases, as a result the refrigeration capacity also increases.

However, when any of the step solenoid valve(for 4-step capacity control system) is opened, the high pressure oil in the cylinder bypasses to the suction port, which causes the piston and the slide valve to move toward the left side, and then some of the refrigerant gas bypasses from the compression chamber back to the suction end. As a result, the refrigeration capacity decreases because of the reduction of displacement of refrigerant gas flowing in the system. The piston spring is used to push the piston back to its original position, i.e. minimum load position in order to reduce the starting current for the next starting.

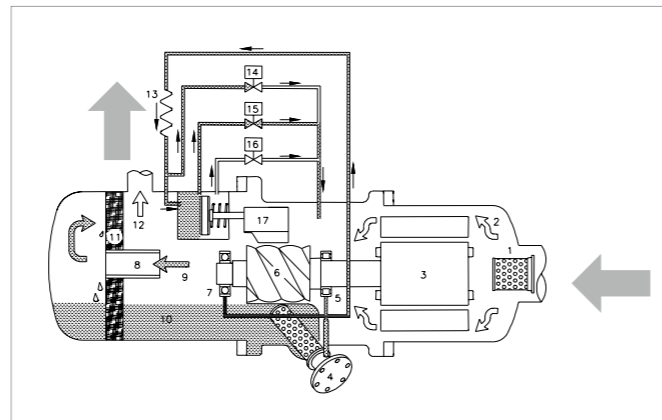

4-steps capacity control

No	Component	No	Component
1	Suction filter	10	Lubricant
2	Gas in(low pressure)	11	Oil separator cartridge
3	Motor	12	Gas out (high pressure without oil)
4	Oil filter cartridge	13	Capillary
5	Suction bearings	14	Solenoid valve, SV2
6	Male rotor	15	Solenoid valve, SV1
7	Discharge bearings	16	Orifice
8	Oil separator baffle	17	Slide valve
9	Gas out(high pressure with oil)		

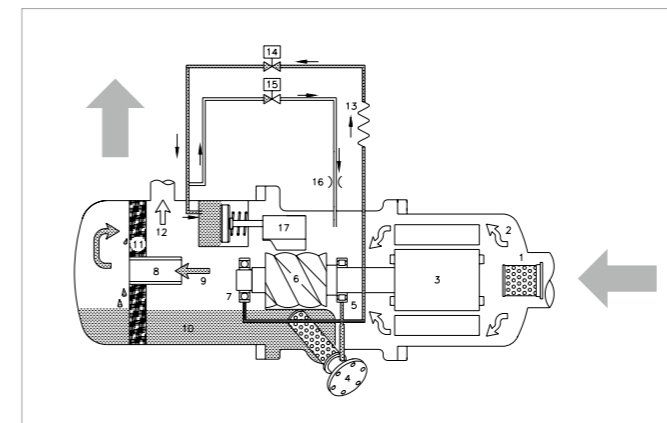

Step-less capacity control

No	Component	No	Component
1	Suction filter	10	Lubricant
2	Gas in(low pressure)	11	Oil separator demister
3	Motor	12	Gas out(high pressure without oil)
4	Oil filter cartridge	13	Capillary
5	Suction bearings	14	Solenoid valve(min. %), SV 25% / 33%
6	Male rotor	15	Solenoid valve (50% of full load), SV 50%
7	Discharge bearings	16	Solenoid valve(75% / 66% of full load), SV 75% / 66%
8	Oil separator baffle	17	Slide valve
9	Gas out(high pressure with oil)	*	For RC2-100, 140 & 180 the SV50% omitted

Heat exchanger

Evaporator Falling film type

"Falling film" shell and tube type evaporator having refrigerant in the shell and chilled water inside the tubes. Advantage of this type evaporator is higher heat transfer performance and reduced refrigerant charge. Distributer located on the top side of inside shell makes uniform flow of refrigerant, this refrigerant flows downward by gravity as a continuous film. The shell is of welded carbon steel construction with steel

tube sheets and copper heat exchange tubes. Removable steel water boxes at both ends of the cooler allow tube cleaning without disturbing the refrigerant circuit.

Tubes are mechanically expanded into tube sheets with double grooves to ensure leak tight and trouble free operation. Multiple compressor/ circuit chillers have coolers with separate refrigeration circuits for each compressor.

Each refrigeration circuit is provided with its own pressure relief valve. All chillers are fitted with drain valves on the removable heads and shell. All coolers are factory insulated with 19mm of closed cell expanded synthetic rubber with all joints vapor sealed.

Expansion device

Expansion unit consists of butterfly valve and orifice. At 100% load situation, the pressure loss at the orifice is smaller than the refrigerant pressure loss in the condenser, thus the super-cooled refrigerant passes through the orifice.

At this stage the maximum amount of refrigerant is flowing into the evaporator. As the load reduces gradually, the circulating amount of refrigerant also reduces and accordingly the refrigerant level in the condenser is getting low.

When the amount of liquid refrigerant reduces, the gas amount in the orifice is getting larger, raising the resistance thus controlling the flow rate.

Control

Controller system information

Generally controller consist of Display, Master, Slave and Relay board. Each board connect with RS485 communication and include analog input/output, digital input/output channel.

- 7 and 10.2-inch color LCD touch screen with high resolution (1,024 x 600)
- Operation scheduling function
- Real time trend display
- Web Access(Additional accessory)
- Running data acquisition
- Easy-to-read display of operational data
- Certified EMI/EMS
- Communication supported: Modbus, RS485(standard)
- Language: English / Chinese / Korean

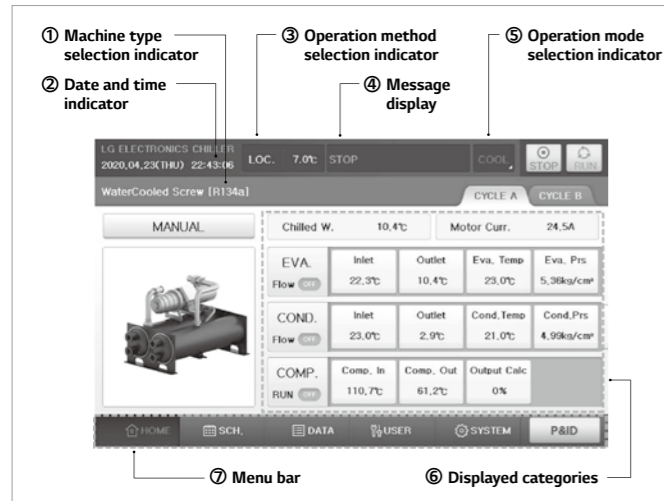

Controller front view

- ① Machine type selection indicator
It show the currently selected model. You can check detail from 'Control Information set' part.
- ② Date and time indicator
It show the current time. You can check detail from 'Sys. Info.(System information)' part.
- ③ Operation method selection indicator
It show the currently selected control mode. You can check detail from 'User set' part.
- ④ Message display
It show the message about status of product.
- ⑤ Operation mode selection indicator
It show the currently selected run mode. You can check detail from 'User set' part.
- ⑥ Displayed categories
It show the currently information of product.
- ⑦ Menu bar
It show the functions for menu operation button.

Features of control unit

The Control unit of LG chiller controls temperature, pressure, current and capacity control valve using high capacity microprocessor. It is constructed to provide the high reliability chiller operation using LG's unique optimum control algorithm.

Controller system composition diagram

Master board and slave board have the same hardware and they are set as master or slave by DIP switch setting. This board consist of analog input/output, digital input/output and communication connections.

BMS support function

Screw chiller's basic communication protocol is Modbus protocol, and it is compatible with the higher level communication methods. Communication protocol support

- Protocol and communication method
 - Standard : Modbus, RS-485
 - Option : BACnet, TCP/IP, Lonwork

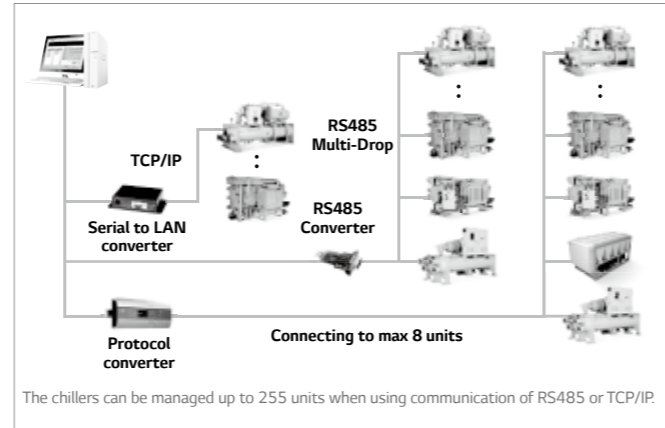

The chillers can be managed up to 255 units when using communication of RS485 or TCP/IP.

Detailed diagrams of BMS

NFB(Non-Fused Breaker) power disconnect switch

A non-fused disconnect is available as a factory-installed option for all units with single point power connection units. This option is that power supply is disconnected during service & repair.

Suction service isolation valve

Service suction isolation valve is installed with unit for each refrigerant circuit as a standard.

General options

Vibration isolation

For installation on building roofs or in sensitive noise areas (hospitals, studios and some residential areas) pre-selected spring type isolators with 1" or 2" deflection are available as a factory option – shipped loose part for field installation.

Power factor correction

Provide equipment with power factor correction capacitors as required to maintain a displacement power factor of 95% at all load conditions.

Water-Cooled Screw chiller standard summary

Items	Standard		Option				
	Standard	Option	400V	415V	440V	460V	480V
Comp.	Power Supply(3Ph)	<input type="checkbox"/> 380V	<input type="checkbox"/> 400V	<input type="checkbox"/> 415V	<input type="checkbox"/> 440V	<input type="checkbox"/> 460V	<input type="checkbox"/> 480V
	Hertz	<input type="checkbox"/> 50Hz	<input type="checkbox"/> 60Hz				
	Capacity Control type	<input type="checkbox"/> Step	<input type="checkbox"/> Stepless				
Control Panel	Angle Valve	<input type="checkbox"/> N/A	<input type="checkbox"/> Yes				
	Communication	<input type="checkbox"/> Modbus	<input type="checkbox"/> BACnet <input type="checkbox"/> TCP/IP <input type="checkbox"/> etc()				
Protection Grade		<input type="checkbox"/> IP4X	<input type="checkbox"/> etc()				
		<input type="checkbox"/> Standard(Single)	<input type="checkbox"/> Multi power Connection				
Factory Wiring		<input type="checkbox"/> Open Wiring	<input type="checkbox"/> Flexible Wiring				
	Supplied by	<input type="checkbox"/> Factory	<input type="checkbox"/> Supplied by customer				
Starter Panel	Starter type	<input type="checkbox"/> Y-Delta(Open)	<input type="checkbox"/> Y-Delta(Closed) <input type="checkbox"/> Soft Starter <input type="checkbox"/> SPG <input type="checkbox"/> Direct				
	Mounted type	<input type="checkbox"/> Unit Mounted	<input type="checkbox"/> Stand Alone				
	Misc. Options	<input type="checkbox"/> N/A	<input type="checkbox"/> Ground Fault Protection <input type="checkbox"/> Power Factor Correction Capacitor <input type="checkbox"/> Integrating Watt-meter				
EVAP.	Power Access	<input type="checkbox"/> From the Top	<input type="checkbox"/> From the Bottom				
	Protection Grade	<input type="checkbox"/> IP4X	<input type="checkbox"/> etc()				
	Waterbox Pressure	<input type="checkbox"/> 150psig(10kg/cm ²)	<input type="checkbox"/> 230psig(16kg/cm ²) <input type="checkbox"/> 300psig(20kg/cm ²)				
COND.	Nozzle Type	<input type="checkbox"/> ANSI-Flange	<input type="checkbox"/> ANSI-Victaulic(AGS) <input type="checkbox"/> ANSI-Victaulic(OGS)				
	Flow proof type(Ref.)	<input type="checkbox"/> Relief V/V(Single)	<input type="checkbox"/> Relief V/V(Dual)				
	Pipe direction(C.B Front st.)	<input type="checkbox"/> Left	<input type="checkbox"/> Right				
Refrigerant Charge	Waterbox Pressure	<input type="checkbox"/> 150psig(10kg/cm ²)	<input type="checkbox"/> 230psig(16kg/cm ²) <input type="checkbox"/> 300psig(20kg/cm ²)				
	Nozzle Type	<input type="checkbox"/> ANSI-Flange	<input type="checkbox"/> ANSI-Victaulic(AGS) <input type="checkbox"/> ANSI-Victaulic(OGS)				
	Flow proof type(Water)	<input type="checkbox"/> N/A	<input type="checkbox"/> DP switch				
Packing	Flow proof type(Ref.)	<input type="checkbox"/> Relief V/V(Single)	<input type="checkbox"/> Relief V/V(Dual)				
	Pipe direction(C.B Front st.)	<input type="checkbox"/> Left	<input type="checkbox"/> Right				
	Insulation	<input type="checkbox"/> Separated Shipping	<input type="checkbox"/> Factory Charge <input type="checkbox"/> Customer supplied				
Sound attenuator	Insulation	<input type="checkbox"/> Shrink film	<input type="checkbox"/> Wooden packing				
		<input type="checkbox"/> Yes	<input type="checkbox"/> N/A				
		<input type="checkbox"/> N/A	<input type="checkbox"/> Yes				
Isolation	Isolation	<input type="checkbox"/> Neoprene PAD	<input type="checkbox"/> Spring 1Inch <input type="checkbox"/> Spring Rubber Pad				
	Anchor Bolt for Foundation	<input type="checkbox"/> N/A	<input type="checkbox"/> Yes				
	Counter Pipe Flange	<input type="checkbox"/> N/A	<input type="checkbox"/> Yes				
Certification	Certification	<input type="checkbox"/> Standard(KGS)	<input type="checkbox"/> ASME VII Only <input type="checkbox"/> CE(PED) <input type="checkbox"/> PED <input type="checkbox"/> (C)JUL(ETL)				
	Factory Performance Test&Process inspec.	<input type="checkbox"/> N/A	<input type="checkbox"/> Report Only <input type="checkbox"/> Customer Witness <input type="checkbox"/> Process inspection				
	Operating Training	<input type="checkbox"/> N/A	<input type="checkbox"/> Yes				
Warranty-Compressor	Warranty-Compressor	<input type="checkbox"/> 1yr	<input type="checkbox"/> etc()				
	Warranty-Ass'y	<input type="checkbox"/> 1yr	<input type="checkbox"/> etc()				
Labor warranty	Labor warranty	<input type="checkbox"/> N/A	<input type="checkbox"/> etc()				
Standard specification		1) Factory Wiring : Open Wiring					
		2) Color : Dawn Gray - Starter / Control Panel : Warm Gray					
		3) Standard provide Emergency stop switch					
		4) Flow proof type : DP Switch(Evaporator)					

R134a(60Hz)

Model		Units	RCWW008CA1B	RCWW010CA1B	RCWW011CA1B	RCWW012CA1B	RCWW014CA1B
AHRI Condition	Cooling capacity	kW	276.0	332.2	376.4	407.0	472.2
		usRT	78.5	94.5	107.0	115.7	134.3
	Input Power	kW	51.6	62.3	70.5	76.1	84.7
		COP	5.35	5.33	5.34	5.35	5.58
General Unit Data	Number of Circuits		1	1	1	1	1
	Refrigerant, R-134a	kg	110	110	110	110	140
	Oil Charge	l	16	16	18	20	20
Weight	Shipping Weight	kg	2,670	2,860	2,950	2,940	3,230
	Operating Weight	kg	2,810	3,020	3,120	3,120	3,460
Compressors	Compressor type		Semi-hermetic twin screw				
	Quantity	EA	1	1	1	1	1
Condenser	Condenser type		Shell and Tube				
	Max. Water Pressure	MPa	1.0	1.0	1.0	1.0	1.0
	Max. Refrigerant Pressure	MPa	1.0	1.0	1.0	1.0	1.0
	Min. Cooling Water Flow Rate	l/s	6.6	7.5	8.5	8.5	10.8
	Max. Cooling Water Flow Rate	l/s	26.5	30.0	34.2	34.2	43.2
	Water Connections	DN	100	100	100	100	125
	Evaporator type		Shell and Tube				
Evaporator	Max. Water Pressure	MPa	1.0	1.0	1.0	1.0	1.0
	Max. Refrigerant Pressure	MPa	0.9	0.9	0.9	0.9	0.9
	Min. Chilled Water Flow Rate	l/s	5.6	7.7	7.7	8.4	10.1
	Max. Chilled Water Flow Rate	l/s	22.3	30.7	30.7	33.5	40.5
	Water Connections	DN	100	100	100	100	125
	Dimension	Length	mm	3,040	3,040	3,040	3,040
Width		mm	1,435	1,435	1,435	1,435	1,480
Height		mm	1,860	1,865	1,865	1,865	2,080

Note:
 1. 1usRT = 3,024kcal/hr = 3.517kW, 1mH₂O = 9.8kPa
 2. AHRI conditions :
 Leaving chilled water temperature is 6.7 °C(44 °F). Water flow is 0.043 L/s per kW(2.4 gpm/ton)
 Entering cooling water temperature is 29.4 °C(85 °F). Water flow is 0.054 L/s per kW(3.0 gpm/ton)
 Fouling factor of water in evaporator is 0.018 m²·°C/kW(0.00001 h-ft²·°F/Btu)
 Fouling factor of water in condenser is 0.044 m²·°C/kW(0.00025 h-ft²·°F/Btu)
 3. Due to our policy of innovation some specification may be changed without prior notification.

R134a(60Hz)

Model		Units	RCWW016CA1B	RCWW018CA1B	RCWW020CA1B	RCWW022CA1B	RCWW020CA2B
AHRI Condition	Cooling capacity	kW	571.6	632.8	681.1	795.9	667.6
		usRT	162.6	180.0	193.7	226.4	189.8
	Input Power	kW	105.0	114.7	124.6	142.0	124.7
		COP	5.44	5.52	5.47	5.61	5.35
General Unit Data	Number of Circuits		1	1	1	1	2
	Refrigerant, R-134a	kg	140	165	165	200	120 x 2
	Oil Charge	l	28	28	28	1	16 / 16
Weight	Shipping Weight	kg	3,560	3,680	3,780	3,880	5,140
	Operating Weight	kg	3,810	3,960	4,060	4,160	5,410
Compressors	Compressor type		Semi-hermetic twin screw				
	Quantity	EA	1	1	1	1	2
Condenser	Condenser type		Shell and Tube				
	Max. Water Pressure	MPa	1.0	1.0	1.0	1.0	1.0
	Max. Refrigerant Pressure	MPa	1.0	1.0	1.0	1.0	1.0
	Min. Cooling Water Flow Rate	l/s	12.0	13.6	13.6	13.6	12.0
	Max. Cooling Water Flow Rate	l/s	48.1	54.4	54.4	54.4	48.1
	Water Connections	DN	125	125	125	125	150
	Evaporator type		Shell and Tube				
Evaporator	Max. Water Pressure	MPa	1.0	1.0	1.0	1.0	1.0
	Max. Refrigerant Pressure	MPa	0.9	0.9	0.9	0.9	0.9
	Min. Chilled Water Flow Rate	l/s	11.2	12.6	12.6	12.6	11.2
	Max. Chilled Water Flow Rate	l/s	44.6	50.2	50.2	50.2	44.6
	Water Connections	DN	125	125	125	125	150
	Dimension	Length	mm	3,145	3,145	3,145	3,365
Width		mm	1,480	1,605	1,605	1,750	1,565
Height		mm	2,080	2,105	2,105	2,150	2,175

Note:
 1. 1usRT = 3,024kcal/hr = 3.517kW, 1mH₂O = 9.8kPa
 2. AHRI conditions :
 Leaving chilled water temperature is 6.7 °C(44 °F). Water flow is 0.043 L/s per kW(2.4 gpm/ton)
 Entering cooling water temperature is 29.4 °C(85 °F). Water flow is 0.054 L/s per kW(3.0 gpm/ton)
 Fouling factor of water in evaporator is 0.018 m²·°C/kW(0.00001 h-ft²·°F/Btu)
 Fouling factor of water in condenser is 0.044 m²·°C/kW(0.00025 h-ft²·°F/Btu)
 3. Due to our policy of innovation some specification may be changed without prior notification.

R134a(60Hz)

Model		Units	RCWW022CA2B	RCWW024CA2B	RCWW026CA2B	RCWW028CA2B	RCWW032CA2B
AHRI Condition	Cooling capacity	kW	754.6	814.0	886.8	945.3	1,141.1
		usRT	214.6	231.5	252.2	268.8	324.5
	Input Power	kW	140.9	152.4	164.7	169.9	210.5
		COP	5.35	5.34	5.38	5.56	5.42
General Unit Data	Number of Circuits		2	2	2	2	2
	Refrigerant, R-134a	kg	120 x 2	120 x 2	120 x 2	145 x 2	145 x 2
	Oil Charge	l	18 / 18	20 / 20	23 / 23	20 / 20	28 / 28
Weight	Shipping Weight	kg	5,460	5,600	5,720	5,770	6,580
	Operating Weight	kg	5,780	5,940	6,080	6,150	7,040
Compressors	Compressor type		Semi-hermetic twin screw				
	Quantity	EA	2	2	2	2	2
Condenser	Condenser type		Shell and Tube				
	Max. Water Pressure	MPa	1.0	1.0	1.0	1.0	1.0
	Max. Refrigerant Pressure	MPa	1.0	1.0	1.0	1.0	1.0
	Min. Cooling Water Flow Rate	l/s	13.6	14.6	14.6	16.9	19.0
	Max. Cooling Water Flow Rate	l/s	54.4	58.6	58.6	67.7	76.0
	Water Connections	DN	150	150	150	150	200
Evaporator	Evaporator type		Shell and Tube				
	Max. Water Pressure	MPa	1.0	1.0	1.0	1.0	1.0
	Max. Refrigerant Pressure	MPa	0.9	0.9	0.9	0.9	0.9
	Min. Chilled Water Flow Rate	l/s	12.6	13.8	13.8	15.7	18.0
	Max. Chilled Water Flow Rate	l/s	50.2	55.1	55.1	62.8	71.8
	Water Connections	DN	150	150	150	150	200
Dimension	Length	mm	3,855	3,855	3,855	3,855	3,855
	Width	mm	1,565	1,565	1,565	1,685	1,685
	Height	mm	2,175	2,175	2,175	2,225	2,225

Note:
 1. 1usRT = 3,024kcal/hr = 3.517kW, 1mH₂O = 9.8kPa
 2. AHRI conditions :
 Leaving chilled water temperature is 6.7 °C(44 °F). Water flow is 0.043 L/s per kW(2.4 gpm/ton)
 Entering cooling water temperature is 29.4 °C(85 °F). Water flow is 0.054 L/s per kW(3.0 gpm/ton)
 Fouling factor of water in evaporator is 0.018 m²·°C/kW(0.00001 h-ft²·°F/Btu)
 Fouling factor of water in condenser is 0.044 m²·°C/kW(0.00025 h-ft²·°F/Btu)
 3. Due to our policy of innovation some specification may be changed without prior notification.

R134a(60Hz)

Model		Units	RCWW036CA2B	RCWW040CA2B	RCWW044CA2B
AHRI Condition	Cooling capacity	kW	1,267.5	1,357.7	1,589.0
		usRT	360.5	386.1	451.9
	Input Power	kW	230.0	249.8	284.7
		COP	5.51	5.44	5.58
General Unit Data	Number of Circuits		2	2	2
	Refrigerant, R-134a	kg	165 x 2	165 x 2	190 x 2
	Oil Charge	l	28 / 28	28 / 28	28 / 28
Weight	Shipping Weight	kg	6,910	6,930	7,430
	Operating Weight	kg	7,430	7,480	7,980
Compressors	Compressor type		Semi-hermetic twin screw		
	Quantity	EA	2	2	2
Condenser	Condenser type		Shell and Tube		
	Max. Water Pressure	MPa	1.0	1.0	1.0
	Max. Refrigerant Pressure	MPa	1.0	1.0	1.0
	Min. Cooling Water Flow Rate	l/s	21.6	21.6	21.6
	Max. Cooling Water Flow Rate	l/s	86.5	86.5	86.5
	Water Connections	DN	200	200	200
Evaporator	Evaporator type		Shell and Tube		
	Max. Water Pressure	MPa	1.0	1.0	1.0
	Max. Refrigerant Pressure	MPa	0.9	0.9	0.9
	Min. Chilled Water Flow Rate	l/s	20.2	20.2	20.2
	Max. Chilled Water Flow Rate	l/s	80.9	80.9	80.9
	Water Connections	DN	200	200	200
Dimension	Length	mm	4,550	4,550	4,550
	Width	mm	1,795	1,795	1,910
	Height	mm	2,275	2,275	2,300

Note:
 1. 1usRT = 3,024kcal/hr = 3.517kW, 1mH₂O = 9.8kPa
 2. AHRI conditions :
 Leaving chilled water temperature is 6.7 °C(44 °F). Water flow is 0.043 L/s per kW(2.4 gpm/ton)
 Entering cooling water temperature is 29.4 °C(85 °F). Water flow is 0.054 L/s per kW(3.0 gpm/ton)
 Fouling factor of water in evaporator is 0.018 m²·°C/kW(0.00001 h-ft²·°F/Btu)
 Fouling factor of water in condenser is 0.044 m²·°C/kW(0.00025 h-ft²·°F/Btu)
 3. Due to our policy of innovation some specification may be changed without prior notification.

R134a(50Hz)

Model		Units	RCWW008CA1B	RCWW010CA1B	RCWW011CA1B	RCWW012CA1B	RCWW014CA1B	RCWW016CA1B
AHRI Condition	Cooling capacity	kW	277.4	337.9	370.1	414.9	473.9	567.2
		usRT	78.9	96.1	105.2	118.0	134.8	161.3
	Input Power	kW	51.8	63.2	68.3	76.2	87.3	103.6
		COP	5.36	5.35	5.42	5.45	5.43	5.48
General Unit Data	Number of Circuits		1	1	1	1	1	1
	Refrigerant, R-134a	kg	110	110	110	110	140	140
	Oil Charge	l	16	16	18	20	20	28
Weight	Shipping Weight	kg	2,800	2,890	2,970	3,030	3,430	3,610
	Operating Weight	kg	2,940	3,050	3,140	3,210	3,660	3,860
Compressors	Compressor type		Semi-hermetic twin screw					
	Quantity	EA	1	1	1	1	1	1
Condenser	Condenser type		Shell and Tube					
	Max. Water Pressure	MPa	1.0	1.0	1.0	1.0	1.0	1.0
	Max. Refrigerant Pressure	MPa	1.0	1.0	1.0	1.0	1.0	1.0
	Min. Cooling Water Flow Rate	l/s	6.6	7.5	8.5	8.5	10.8	12.0
	Max. Cooling Water Flow Rate	l/s	26.5	30.0	34.2	34.2	43.2	48.1
	Water Connections	DN	100	100	100	100	125	125
	Evaporator type		Shell and Tube					
Evaporator	Max. Water Pressure	MPa	1.0	1.0	1.0	1.0	1.0	1.0
	Max. Refrigerant Pressure	MPa	0.9	0.9	0.9	0.9	0.9	0.9
	Min. Chilled Water Flow Rate	l/s	5.6	7.7	7.7	8.4	10.1	11.2
	Max. Chilled Water Flow Rate	l/s	22.3	30.7	30.7	33.5	40.5	44.6
	Water Connections	DN	100	100	100	100	125	125
	Dimension	Length	mm	3,040	3,040	3,040	3,040	3,145
Width		mm	1,435	1,435	1,435	1,435	1,480	1,480
Height		mm	1,860	1,865	1,865	1,865	2,080	2,080

Note:
 1. 1usRT = 3,024kcal/hr = 3.517kW, 1mH₂O = 9.8kPa
 2. AHRI conditions :
 Leaving chilled water temperature is 6.7 °C(44 °F). Water flow is 0.043 L/s per kW(2.4 gpm/ton)
 Entering cooling water temperature is 29.4 °C(85 °F). Water flow is 0.054 L/s per kW(3.0 gpm/ton)
 Fouling factor of water in evaporator is 0.018 m²·°C/kW(0.00001 h-ft²·°F/Btu)
 Fouling factor of water in condenser is 0.044 m²·°C/kW(0.00025 h-ft²·°F/Btu)
 3. Due to our policy of innovation some specification may be changed without prior notification.

R134a(50Hz)

Model		Units	RCWW019CA1B	RCWW020CA2B	RCWW022CA2B	RCWW024CA2B	RCWW028CA2B	RCWW032CA2B	RCWW038CA2B
AHRI Condition	Cooling capacity	kW	657.9	679.3	741.2	829.9	948.9	1,132.3	1,317.9
		usRT	187.1	193.2	210.8	236.0	269.9	322.0	374.8
	Input Power	kW	118.2	126.5	136.6	152.5	175.1	207.6	237.0
		COP	5.57	5.37	5.43	5.44	5.42	5.45	5.56
General Unit Data	Number of Circuits		1	2	2	2	2	2	2
	Refrigerant, R-134a	kg	165	120 x 2	120 x 2	120 x 2	145 x 2	145 x 2	165 x 2
	Oil Charge	l	28	16 / 16	18 / 18	20 / 20	20 / 20	28 / 28	28 / 28
Weight	Shipping Weight	kg	3,720	5,220	5,500	5,780	6,180	6,680	6,990
	Operating Weight	kg	4,000	5,490	5,860	6,120	6,560	7,140	7,510
Compressors	Compressor type		Semi-hermetic twin screw						
	Quantity	EA	1	2	2	2	2	2	2
Condenser	Condenser type		Shell and Tube						
	Max. Water Pressure	MPa	1.0	1.0	1.0	1.0	1.0	1.0	1.0
	Max. Refrigerant Pressure	MPa	1.0	1.0	1.0	1.0	1.0	1.0	1.0
	Min. Cooling Water Flow Rate	l/s	13.6	12.0	13.6	14.6	16.9	19.0	21.6
	Max. Cooling Water Flow Rate	l/s	54.4	48.1	54.4	58.6	67.7	76.0	86.5
	Water Connections	DN	125	150	150	150	150	200	200
	Evaporator type		Shell and Tube						
Evaporator	Max. Water Pressure	MPa	1.0	1.0	1.0	1.0	1.0	1.0	1.0
	Max. Refrigerant Pressure	MPa	0.9	0.9	0.9	0.9	0.9	0.9	0.9
	Min. Chilled Water Flow Rate	l/s	12.6	11.2	12.6	13.8	15.7	18.0	20.2
	Max. Chilled Water Flow Rate	l/s	50.2	44.6	50.2	55.1	62.8	71.8	80.9
	Water Connections	DN	125	150	150	150	150	200	200
	Dimension	Length	mm	3,145	3,855	3,855	3,855	3,855	3,855
Width		mm	1,605	1,565	1,565	1,565	1,685	1,685	1,795
Height		mm	2,105	2,175	2,175	2,175	2,225	2,225	2,275

Note:
 1. 1usRT = 3,024kcal/hr = 3.517kW, 1mH₂O = 9.8kPa
 2. AHRI conditions :
 Leaving chilled water temperature is 6.7 °C(44 °F). Water flow is 0.043 L/s per kW(2.4 gpm/ton)
 Entering cooling water temperature is 29.4 °C(85 °F). Water flow is 0.054 L/s per kW(3.0 gpm/ton)
 Fouling factor of water in evaporator is 0.018 m²·°C/kW(0.00001 h-ft²·°F/Btu)
 Fouling factor of water in condenser is 0.044 m²·°C/kW(0.00025 h-ft²·°F/Btu)
 3. Due to our policy of innovation some specification may be changed without prior notification.

380V / 60Hz

Model	Circuit	Voltage	Compressor			Total RLA	Max Current	MCA	MOCP
			LRA	RLA	Start Current				
RCWW008CA1B	Circuit 1	380	810	88	270	96	270	129	232
RCWW010CA1B	Circuit 1		820	112	273	122	273	165	296
RCWW011CA1B	Circuit 1		985	125	328	135	328	181	325
RCWW012CA1B	Circuit 1		985	134	328	145	328	195	350
RCWW014CA1B	Circuit 1		1,115	150	372	162	372	217	390
RCWW016CA1B	Circuit 1		1,750	188	583	203	583	270	486
RCWW018CA1B	Circuit 1		1,930	200	643	218	643	294	529
RCWW020CA1B	Circuit 1		2,185	217	728	236	728	316	569
RCWW022CA1B	Circuit 1		2,470	248	823	269	823	360	647
RCWW020CA2B	Circuit 1		820	112	273	224	385	329	592
	Circuit 2		820	112	273				
RCWW022CA2B	Circuit 1		985	125	328	249	453	362	651
	Circuit 2		985	125	328				
RCWW024CA2B	Circuit 1		985	134	328	267	462	389	700
	Circuit 2		985	134	328				
RCWW026CA2B	Circuit 1		1,115	146	372	293	518	422	759
	Circuit 2		1,115	146	372				
RCWW028CA2B	Circuit 1		1,115	150	372	300	522	434	781
	Circuit 2		1,115	150	372				
RCWW032CA2B	Circuit 1		1,750	188	583	376	771	541	973
	Circuit 2		1,750	188	583				
RCWW036CA2B	Circuit 1		1,930	200	643	400	843	588	1,058
	Circuit 2		1,930	200	643				
RCWW040CA2B	Circuit 1		2,185	217	728	434	945	632	1,138
	Circuit 2	2,185	217	728					
RCWW044CA2B	Circuit 1	2,470	248	823	496	1,071	719	1,294	
	Circuit 2	2,470	248	823					

Note:
 1. AHRI conditions :
 Leaving chilled water temperature is 6.7°F(44°C)
 Entering cooling water temperature is 29.4°F(85°C)
 2. Symbols :
 LRA : Locked Rotor Ampere
 RLA : Rated Load Ampere
 MCA : Minimum Circuit Ampere
 MOCP : Maximum OverCurrent Protection
 Total RLA : Current when all compressor running
 Start Current : Starting current of one compressor
 Max current : Start current(Circuit 1) + RLA(Circuit 2)

440V / 60Hz

Model	Circuit	Voltage	Compressor			Total RLA	Max Current	MCA	MOCP
			LRA	RLA	Start Current				
RCWW008CA1B	Circuit 1	440	690	77	230	77	230	111	200
RCWW010CA1B	Circuit 1		700	97	233	97	233	142	256
RCWW011CA1B	Circuit 1		810	108	270	108	270	156	281
RCWW012CA1B	Circuit 1		810	115	270	115	270	168	302
RCWW014CA1B	Circuit 1		875	130	292	130	292	187	337
RCWW016CA1B	Circuit 1		1,340	162	447	162	447	233	420
RCWW018CA1B	Circuit 1		1,430	173	477	173	477	254	457
RCWW020CA1B	Circuit 1		1,565	188	522	188	522	273	491
RCWW022CA1B	Circuit 1		1,990	214	663	214	663	310	559
RCWW020CA2B	Circuit 1		700	97	233	194	331	284	511
	Circuit 2		700	97	233				
RCWW022CA2B	Circuit 1		810	108	270	215	378	312	562
	Circuit 2		810	108	270				
RCWW024CA2B	Circuit 1		810	115	270	231	385	336	605
	Circuit 2		810	115	270				
RCWW026CA2B	Circuit 1		875	126	292	252	418	364	656
	Circuit 2		875	126	292				
RCWW028CA2B	Circuit 1		875	130	292	259	421	375	675
	Circuit 2		875	130	292				
RCWW032CA2B	Circuit 1		1,340	162	447	325	609	467	840
	Circuit 2		1,340	162	447				
RCWW036CA2B	Circuit 1		1,430	173	477	346	650	508	914
	Circuit 2		1,430	173	477				
RCWW040CA2B	Circuit 1		1,565	188	522	375	709	546	982
	Circuit 2	1,565	188	522					
RCWW044CA2B	Circuit 1	1,990	214	663	429	878	621	1,117	
	Circuit 2	1,990	214	663					

Note:
 1. AHRI conditions :
 Leaving chilled water temperature is 6.7°F(44°C)
 Entering cooling water temperature is 29.4°F(85°C)
 2. Symbols :
 LRA : Locked Rotor Ampere
 RLA : Rated Load Ampere
 MCA : Minimum Circuit Ampere
 MOCP : Maximum OverCurrent Protection
 Total RLA : Current when all compressor running
 Start Current : Starting current of one compressor
 Max current : Start current(Circuit 1) + RLA(Circuit 2)

460V / 60Hz

Model	Circuit	Voltage	Compressor			Total RLA	Max Current	MCA	MOCP
			LRA	RLA	Start Current				
RCWW008CA1B	Circuit 1	460	720	73	240	73	240	107	192
RCWW010CA1B	Circuit 1		730	93	243	93	243	136	245
RCWW011CA1B	Circuit 1		845	103	282	103	282	149	269
RCWW012CA1B	Circuit 1		845	110	282	110	282	161	289
RCWW014CA1B	Circuit 1		915	124	305	124	305	179	322
RCWW016CA1B	Circuit 1		1,400	155	467	155	467	223	402
RCWW018CA1B	Circuit 1		1,495	166	498	166	498	243	437
RCWW020CA1B	Circuit 1		1,635	179	545	179	545	261	470
RCWW022CA1B	Circuit 1		2,080	205	693	205	693	297	534
RCWW020CA2B	Circuit 1		730	93	243	186	336	272	489
	Circuit 2		730	93	243				
RCWW022CA2B	Circuit 1		845	103	282	206	384	299	537
	Circuit 2		845	103	282				
RCWW024CA2B	Circuit 1		845	110	282	221	392	321	578
	Circuit 2		845	110	282				
RCWW026CA2B	Circuit 1		915	121	305	241	426	349	627
	Circuit 2		915	121	305				
RCWW028CA2B	Circuit 1		915	124	305	248	429	358	645
	Circuit 2		915	124	305				
RCWW032CA2B	Circuit 1		1,400	155	467	311	622	447	804
	Circuit 2		1,400	155	467				
RCWW036CA2B	Circuit 1		1,495	166	498	331	664	485	873
	Circuit 2		1,495	166	498				
RCWW040CA2B	Circuit 1		1,635	179	545	359	724	522	940
	Circuit 2	1,635	179	545					
RCWW044CA2B	Circuit 1	2,080	205	693	410	898	594	1,069	
	Circuit 2	2,080	205	693					

Note:
 1. AHRI conditions :
 Leaving chilled water temperature is 6.7°F(44°C)
 Entering cooling water temperature is 29.4°F(85°C)
 2. Symbols :
 LRA : Locked Rotor Ampere
 RLA : Rated Load Ampere
 MCA : Minimum Circuit Ampere
 MOCP : Maximum OverCurrent Protection
 Total RLA : Current when all compressor running
 Start Current : Starting current of one compressor
 Max current : Start current(Circuit 1) + RLA(Circuit 2)

480V / 60Hz

Model	Circuit	Voltage	Compressor			Total RLA	Max Current	MCA	MOCP
			LRA	RLA	Start Current				
RCWW008CA1B	Circuit 1	480	655	70	218	70	218	102	184
RCWW010CA1B	Circuit 1		690	89	230	89	230	130	234
RCWW011CA1B	Circuit 1		795	99	265	99	265	143	257
RCWW012CA1B	Circuit 1		795	106	265	106	265	154	277
RCWW014CA1B	Circuit 1		850	119	283	119	283	172	309
RCWW016CA1B	Circuit 1		1,295	149	432	149	432	214	385
RCWW018CA1B	Circuit 1		1,370	159	457	159	457	233	419
RCWW020CA1B	Circuit 1		1,485	172	495	172	495	250	450
RCWW022CA1B	Circuit 1		1,850	197	617	197	617	285	512
RCWW020CA2B	Circuit 1		690	89	230	178	319	261	469
	Circuit 2		690	89	230				
RCWW022CA2B	Circuit 1		795	99	265	197	364	286	515
	Circuit 2		795	99	265				
RCWW024CA2B	Circuit 1		795	106	265	212	371	308	554
	Circuit 2		795	106	265				
RCWW026CA2B	Circuit 1		850	116	283	231	399	334	601
	Circuit 2		850	116	283				
RCWW028CA2B	Circuit 1		850	119	283	238	402	344	618
	Circuit 2		850	119	283				
RCWW032CA2B	Circuit 1		1,295	149	432	298	580	428	770
	Circuit 2		1,295	149	432				
RCWW036CA2B	Circuit 1		1,370	159	457	317	615	465	837
	Circuit 2		1,370	159	457				
RCWW040CA2B	Circuit 1		1,485	172	495	344	667	500	900
	Circuit 2	1,485	172	495					
RCWW044CA2B	Circuit 1	1,850	197	617	393	813	569	1,024	
	Circuit 2	1,850	197	617					

Note:
 1. AHRI conditions :
 Leaving chilled water temperature is 6.7°F(44°C)
 Entering cooling water temperature is 29.4°F(85°C)
 2. Symbols :
 LRA : Locked Rotor Ampere
 RLA : Rated Load Ampere
 MCA : Minimum Circuit Ampere
 MOCP : Maximum OverCurrent Protection
 Total RLA : Current when all compressor running
 Start Current : Starting current of one compressor
 Max current : Start current(Circuit 1) + RLA(Circuit 2)

380V / 50Hz

Model	Circuit	Voltage	Compressor			Total RLA	Max Current	MCA	MOCP
			LRA	RLA	Start Current				
RCWW008CA1B	Circuit 1	380	700	95	233	95	233	138	248
RCWW010CA1B	Circuit 1		810	113	270	113	270	164	295
RCWW011CA1B	Circuit 1		875	125	292	125	292	179	322
RCWW012CA1B	Circuit 1		1,220	134	407	134	407	194	350
RCWW014CA1B	Circuit 1		1,340	160	447	160	447	230	415
RCWW016CA1B	Circuit 1		1,565	182	522	182	522	266	478
RCWW019CA1B	Circuit 1		1,990	209	663	209	663	304	547
RCWW020CA2B	Circuit 1		810	113	270	240	383	327	589
	Circuit 2		810	113	270				
RCWW022CA2B	Circuit 1		875	125	292	270	416	358	644
	Circuit 2		875	125	292				
RCWW024CA2B	Circuit 1		1,220	134	407	290	540	389	699
	Circuit 2		1,220	134	407				
RCWW028CA2B	Circuit 1		1,340	160	447	312	607	461	829
	Circuit 2		1,340	160	447				
RCWW032CA2B	Circuit 1		1,565	182	522	390	704	531	956
	Circuit 2		1,565	182	522				
RCWW038CA2B	Circuit 1		1,990	209	663	418	872	608	1,094
	Circuit 2		1,990	209	663				

Note:
 1. AHRI conditions :
 Leaving chilled water temperature is 6.7°F(44°C)
 Entering cooling water temperature is 29.4°F(85°C)
 2. Symbols :
 LRA : Locked Rotor Ampere
 RLA : Rated Load Ampere
 MCA : Minimum Circuit Ampere
 MOCP : Maximum OverCurrent Protection
 Total RLA : Current when all compressor running
 Start Current : Starting current of one compressor
 Max current : Start current(Circuit 1) + RLA(Circuit 2)

400V / 50Hz

Model	Circuit	Voltage	Compressor			Total RLA	Max Current	MCA	MOCP
			LRA	RLA	Start Current				
RCWW008CA1B	Circuit 1	400	730	92	243	92	243	134	241
RCWW010CA1B	Circuit 1		845	110	282	110	282	159	286
RCWW011CA1B	Circuit 1		915	121	305	121	305	174	313
RCWW012CA1B	Circuit 1		1,285	130	428	130	428	189	340
RCWW014CA1B	Circuit 1		1,400	156	467	156	467	224	404
RCWW016CA1B	Circuit 1		1,635	177	545	177	545	258	465
RCWW019CA1B	Circuit 1		2,080	203	693	203	693	295	532
RCWW020CA2B	Circuit 1		845	110	282	220	392	318	573
	Circuit 2		845	110	282				
RCWW022CA2B	Circuit 1		915	121	305	242	426	348	627
	Circuit 2		915	121	305				
RCWW024CA2B	Circuit 1		1,285	130	428	260	558	378	680
	Circuit 2		1,285	130	428				
RCWW028CA2B	Circuit 1		1,400	157	467	313	623	449	807
	Circuit 2		1,400	157	467				
RCWW032CA2B	Circuit 1		1,635	178	545	355	723	516	929
	Circuit 2		1,635	178	545				
RCWW038CA2B	Circuit 1		2,080	203	693	407	897	591	1,063
	Circuit 2		2,080	203	693				

Note:
 1. AHRI conditions :
 Leaving chilled water temperature is 6.7°F(44°C)
 Entering cooling water temperature is 29.4°F(85°C)
 2. Symbols :
 LRA : Locked Rotor Ampere
 RLA : Rated Load Ampere
 MCA : Minimum Circuit Ampere
 MOCP : Maximum OverCurrent Protection
 Total RLA : Current when all compressor running
 Start Current : Starting current of one compressor
 Max current : Start current(Circuit 1) + RLA(Circuit 2)

415V / 50Hz

Model	Circuit	Voltage	Compressor			Total RLA	Max Current	MCA	MOCP
			LRA	RLA	Start Current				
RCWW008CA1B	Circuit 1	415	690	87	230	87	230	126	227
RCWW010CA1B	Circuit 1		795	104	265	104	265	150	270
RCWW011CA1B	Circuit 1		850	114	283	114	283	164	295
RCWW012CA1B	Circuit 1		1,160	122	387	122	387	178	320
RCWW014CA1B	Circuit 1		1,295	147	432	147	432	211	380
RCWW016CA1B	Circuit 1		1,485	167	495	167	495	243	438
RCWW019CA1B	Circuit 1		1,850	191	617	191	617	278	501
RCWW020CA2B	Circuit 1		795	104	265	207	369	300	539
	Circuit 2		795	104	265				
RCWW022CA2B	Circuit 1		850	114	283	228	397	328	590
	Circuit 2		850	114	283				
RCWW024CA2B	Circuit 1		1,160	123	387	245	509	356	640
	Circuit 2		1,160	123	387				
RCWW028CA2B	Circuit 1		1,295	147	432	294	579	422	760
	Circuit 2		1,295	147	432				
RCWW032CA2B	Circuit 1		1,485	167	495	334	662	486	875
	Circuit 2		1,485	167	495				
RCWW038CA2B	Circuit 1		1,850	192	617	383	808	556	1,001
	Circuit 2		1,850	192	617				

Note:
 1. AHRI conditions :
 Leaving chilled water temperature is 6.7°F(44°C)
 Entering cooling water temperature is 29.4°F(85°C)
 2. Symbols :
 LRA : Locked Rotor Ampere
 RLA : Rated Load Ampere
 MCA : Minimum Circuit Ampere
 MOCP : Maximum OverCurrent Protection
 Total RLA : Current when all compressor running
 Start Current : Starting current of one compressor
 Max current : Start current(Circuit 1) + RLA(Circuit 2)

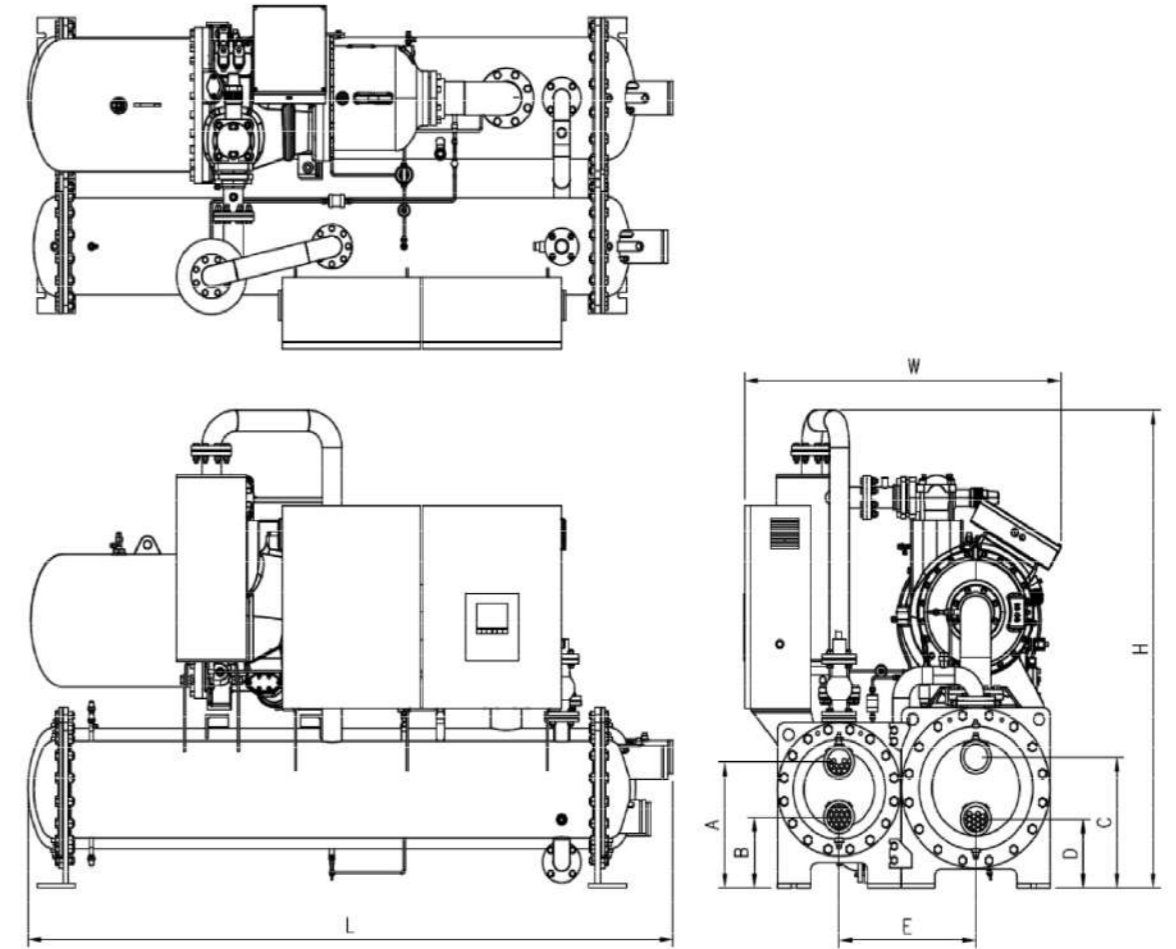

Frequency	Model	L	W	H	A	B	C	D	E
60Hz	RCWW008CA1B	3,040	1,435	1,860	543	283	559	299	595
	RCWW010CA1B	3,040	1,435	1,860	543	283	559	299	595
	RCWW011CA1B	3,040	1,435	1,860	543	283	559	299	595
	RCWW012CA1B	3,040	1,435	1,860	543	283	559	299	595
	RCWW014CA1B	3,145	1,480	2,080	632	392	667	407	655
	RCWW016CA1B	3,145	1,480	2,080	632	392	667	407	655
	RCWW018CA1B	3,145	1,605	2,105	657	357	642	342	715
	RCWW020CA1B	3,145	1,605	2,105	657	357	642	342	715
	RCWW022CA1B	3,365	1,750	2,150	692	432	717	458	775
50Hz	RCWW008CA1B	3,040	1,435	1,860	543	283	559	299	595
	RCWW010CA1B	3,040	1,435	1,860	543	283	559	299	595
	RCWW011CA1B	3,040	1,435	1,860	543	283	559	299	595
	RCWW012CA1B	3,040	1,435	1,860	543	283	559	299	595
	RCWW014CA1B	3,145	1,480	2,080	632	392	667	407	655
	RCWW016CA1B	3,145	1,480	2,080	632	392	667	407	655
	RCWW019CA1B	3,145	1,605	2,105	657	357	642	342	715

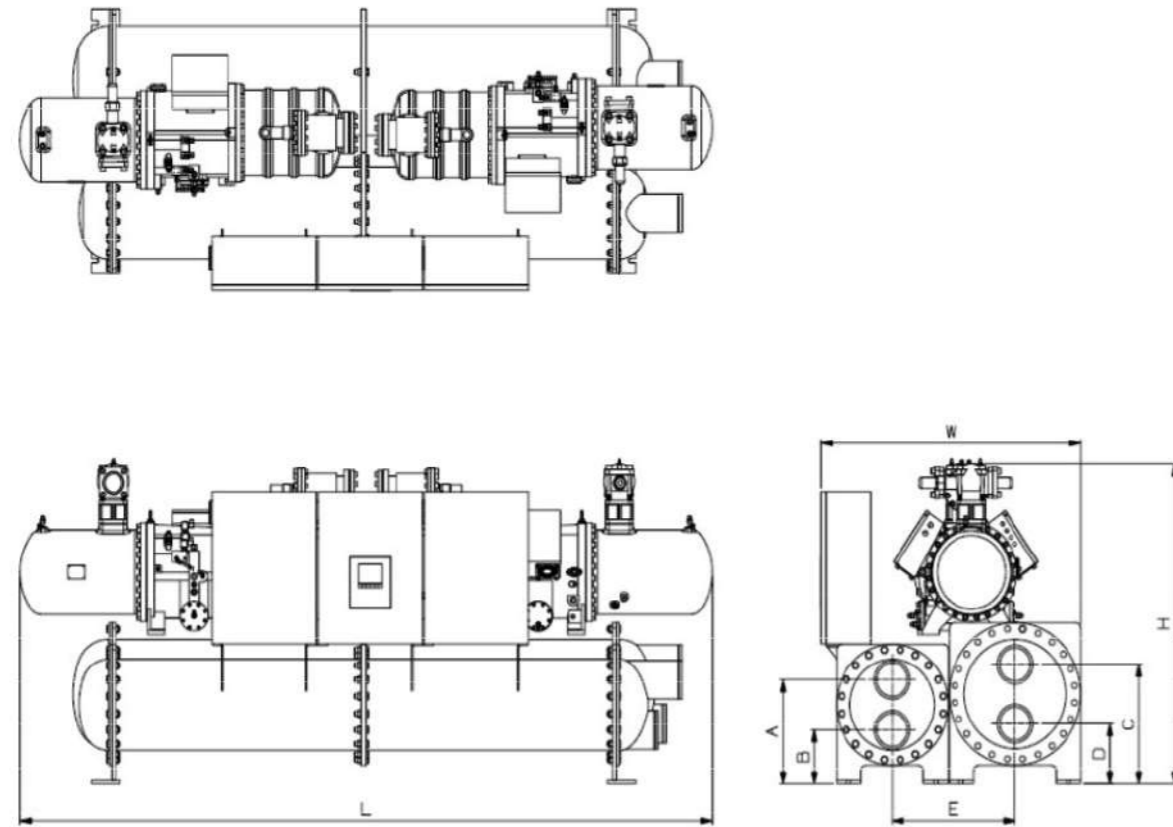

Frequency	Model	L	W	H	A	B	C	D	E
60Hz	RCWW020CA2B	3,855	1,565	2,175	645	335	665	365	740
	RCWW022CA2B	3,855	1,565	2,175	645	335	665	365	740
	RCWW024CA2B	3,855	1,565	2,175	645	335	665	365	740
	RCWW026CA2B	3,855	1,565	2,175	645	335	665	365	740
	RCWW028CA2B	3,855	1,685	2,225	667	407	763	463	800
	RCWW032CA2B	3,855	1,685	2,225	667	407	763	463	800
	RCWW036CA2B	4,550	1,795	2,275	747	427	789	489	855
	RCWW040CA2B	4,550	1,795	2,275	747	427	789	489	855
	RCWW044CA2B	4,550	1,910	2,300	763	463	834	474	915
50Hz	RCWW020CA2B	3,855	1,565	2,175	645	335	665	365	740
	RCWW022CA2B	3,855	1,565	2,175	645	335	665	365	740
	RCWW024CA2B	3,855	1,565	2,175	645	335	665	365	740
	RCWW028CA2B	3,855	1,685	2,225	667	407	763	463	800
	RCWW032CA2B	3,855	1,685	2,225	667	407	763	463	800
	RCWW038CA1B	4,550	1,795	2,275	747	427	789	489	855

1 Compressor model

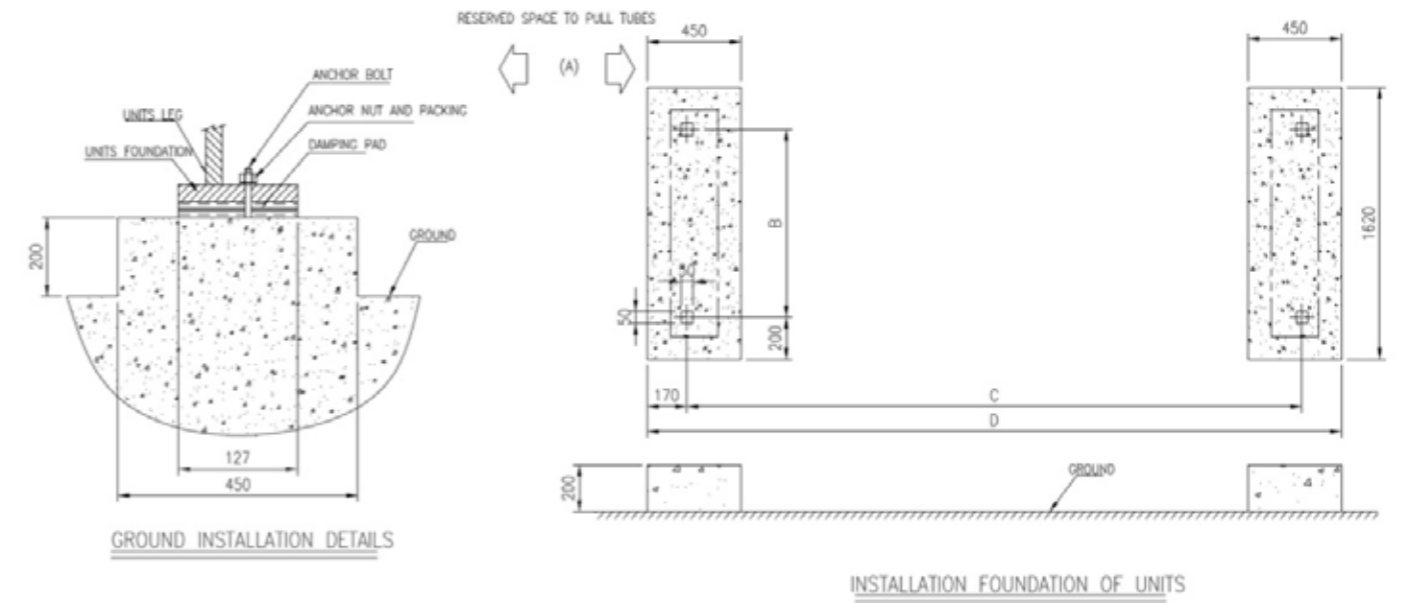

Frequency	Model	A	B	C	D
60Hz	RCWW008CA1B	2,500	1,035	2,530	2,870
	RCWW010CA1B	2,500	1,035	2,530	2,870
	RCWW011CA1B	2,500	1,035	2,530	2,870
	RCWW012CA1B	2,500	1,035	2,530	2,870
	RCWW014CA1B	2,500	1,150	2,530	2,870
	RCWW016CA1B	2,500	1,150	2,530	2,870
	RCWW018CA1B	2,500	1,275	2,530	2,870
	RCWW020CA1B	2,500	1,275	2,530	2,870
	RCWW022CA1B	2,500	1,395	2,530	2,870
50Hz	RCWW008CA1B	2,500	1,035	2,530	2,870
	RCWW010CA1B	2,500	1,035	2,530	2,870
	RCWW011CA1B	2,500	1,035	2,530	2,870
	RCWW012CA1B	2,500	1,035	2,530	2,870
	RCWW014CA1B	2,500	1,150	2,530	2,870
	RCWW016CA1B	2,500	1,150	2,530	2,870
	RCWW019CA1B	2,500	1,275	2,530	2,870

2 Compressor model

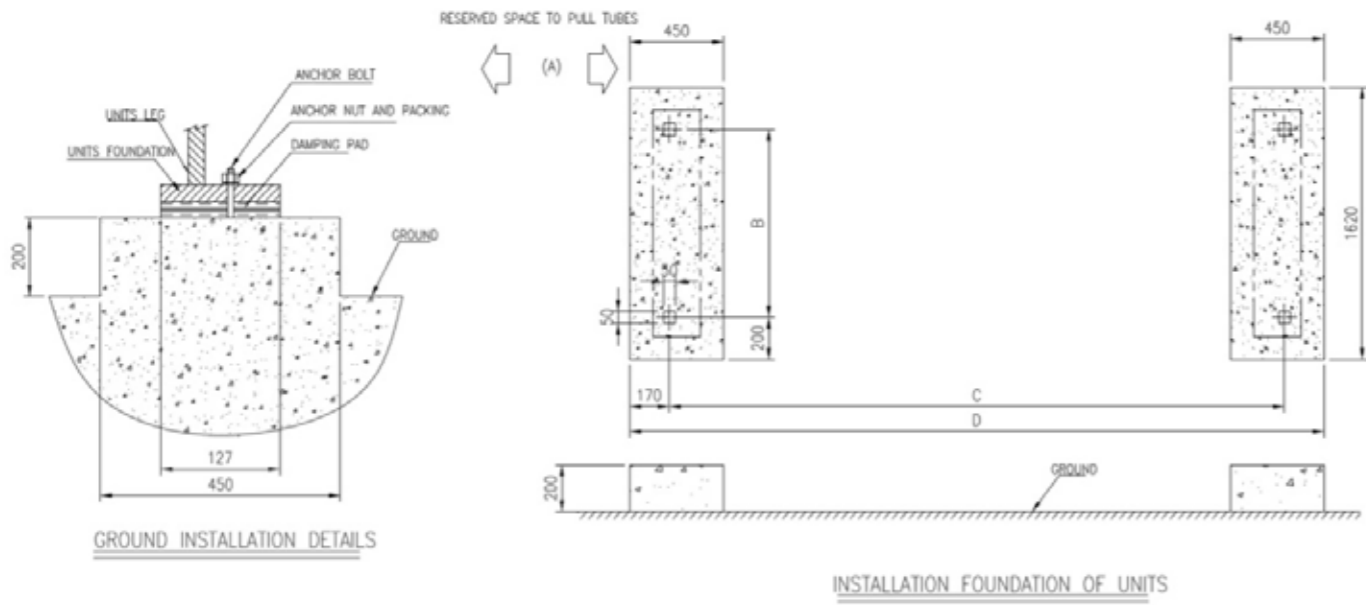

Frequency	Model	A	B	C	D
60Hz	RCWW020CA2B	3,100	1,325	3,128	3,468
	RCWW022CA2B	3,100	1,325	3,128	3,468
	RCWW024CA2B	3,100	1,325	3,128	3,468
	RCWW026CA2B	3,100	1,325	3,128	3,468
	RCWW028CA2B	3,100	1,445	3,128	3,468
	RCWW032CA2B	3,100	1,445	3,128	3,468
	RCWW036CA2B	3,100	1,555	3,128	3,468
	RCWW040CA2B	3,100	1,555	3,128	3,468
50Hz	RCWW044CA2B	3,100	1,670	3,128	3,468
	RCWW020CA2B	3,100	1,325	3,128	3,468
	RCWW022CA2B	3,100	1,325	3,128	3,468
	RCWW024CA2B	3,100	1,325	3,128	3,468
	RCWW028CA2B	3,100	1,445	3,128	3,468
	RCWW032CA2B	3,100	1,445	3,128	3,468
RCWW038CA1B	3,100	1,555	3,128	3,468	

SYMBOL	DESCRIPTION	SYMBOL	DESCRIPTION
	Solenoid valve		High pressure switch
	Electric expansion valve		Low pressure switch
	Expansion device		Differential pressure switch
	Angle valve		Oil level switch
	Ball valve		Flow switch
	Safety valve		Pressure sensor
	Butterfly valve		Temperature sensor
	Check valve		Strainer
	Tee		Filter dryer
	Flange connection		Sight glass
	Reducer		Ejector

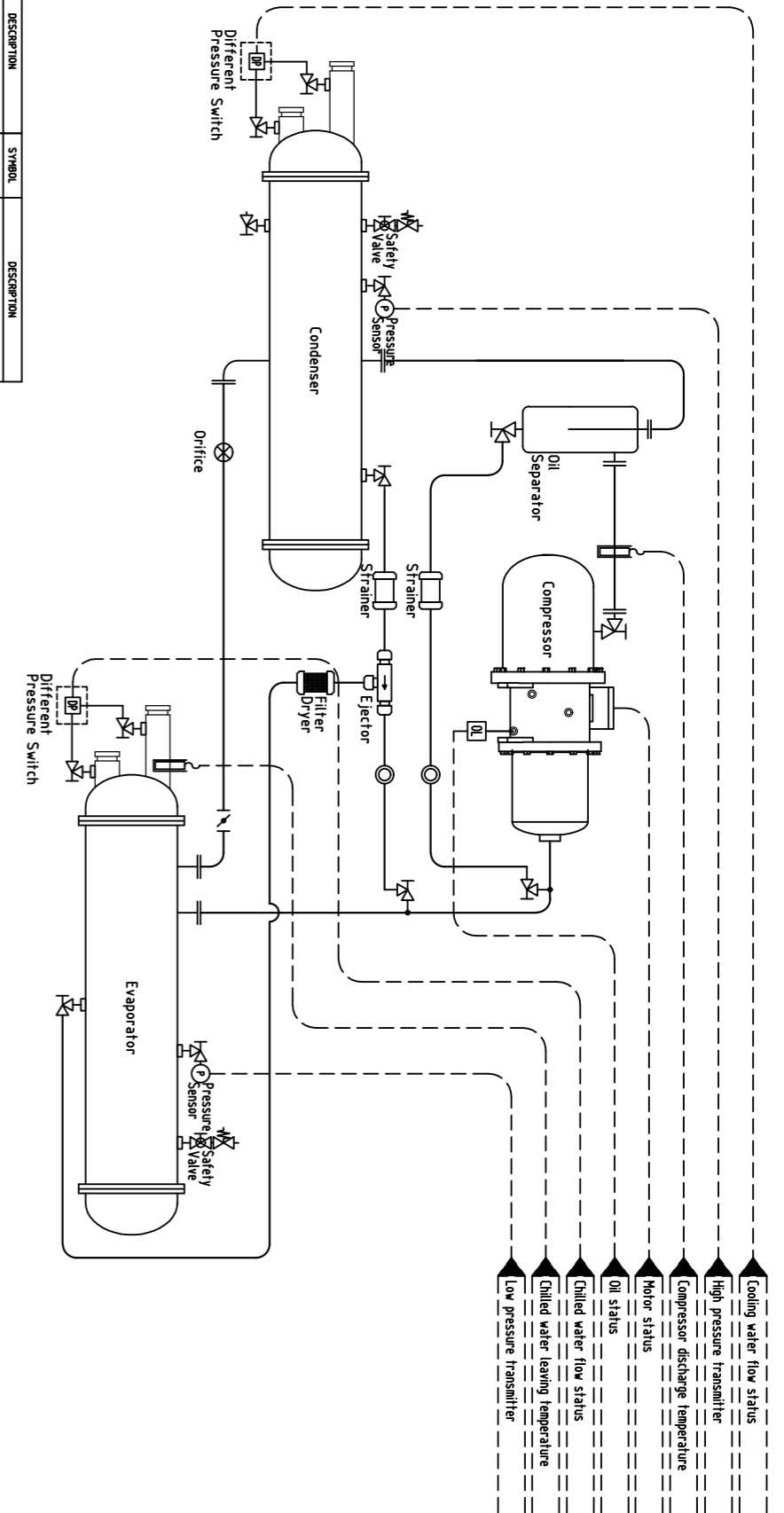

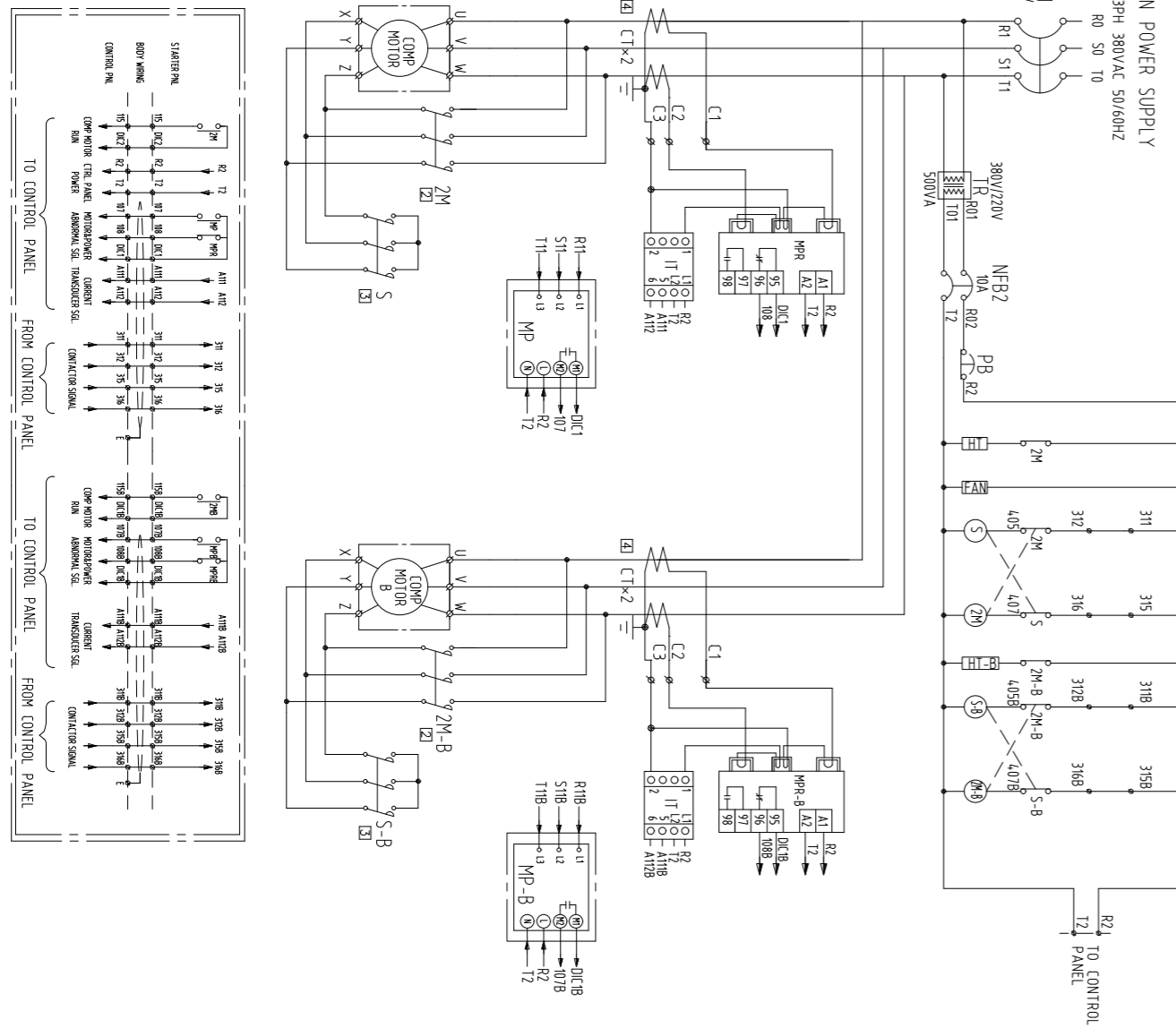

Checking of the site information

Before installing the chiller unit, check the site in advance, review the necessary details and coordinate the followings with the site personnel so that the installation can be performed safely and accurately.

- 1) Work scope and unit data: Check the site installation work scope and approved document
- 2) Installation location: Check the environmental condition to install according to the article 3-2.
- 3) Check the entrance size(width, length and height) to the installing site in advance not to have any trouble in moving. Then check and review the detail method and order for moving the unit.

The environmental condition of installation site

The site space to install or store the product along with the following environmental condition should be considered.

- 1) Be careful not to damage the piping, insulation materials and wires of the chiller unit when storing and installing. The site should have ventilation measures for the refrigerant leakage.
- 2) Select site where the temperature is below 40 °C all the time with good ventilation. When the unit is to be stored for long term, pay a close attention to the temperature of the site to be maintained below 40 °C all the time. If the chiller unit is charged with refrigerant and the pressure of the unit exceeds the limit, the pressure relief valve will be operated and discharge the refrigerant gas resulting in the loss of refrigerant gas along with potential loss of lives. If the machine room temperature is over 40 °C, the pressure vessel should be reconfigured. Check the set pressure for the relief valve of the chiller unit and maintain the room below the relief valve operating temperature consulting the authorized service engineer of LG Electronics.
- 3) Store the chiller unit in dry and safe location without any vibration.
- 4) The floor surface to install the chiller unit should be flat and of sufficient strength and mass to support the chiller operating weight.
- 5) Avoid place of any fire or flammable materials near. When installed in parallel to the heating object such as a boiler, sufficient care to the radiation heat is required.
- 6) Be careful with high humidity as it causes the electric error and the corrosion of the chiller unit.
- 7) Select the site where less dust are as the dust cause electric error.
- 8) Provide enough space around the unit to allow the installation and maintenance personnel access to all service points such as replacing heat exchanger tubes and waterbox to open.
- 9) Secure maximum or safe height to fit to the crane for easy lifting and lowering of the chiller unit.
- 10) Secure good drainage from the machine room.
- 11) Secure sufficient lighting considering the repair and maintenance.
- 12) This chiller unit is manufactured for indoor use. Therefore avoid installing outdoors or a place under direct sunlight.
- 13) Protect the unit by vinyl cover form dust and rains.
- 14) When installing the chiller unit, plan appropriately in accordance with the installation of High Pressure Gas Safety Control Act. (Local standard)

500 /5A	225A	225A	1000A	520RT	
400 /5A	225A	225A	800A	440RT	R22
300 /5A	185A	185A	700A	400RT	
400 /5A	185A	185A	600A	350RT	
300 /5A	150A	150A	600A	300RT	
400 /5A	185A	185A	700A	390RT	
300 /5A	185A	185A	600A	370RT	
250 /5A	130A	130A	500A	280RT	
200 /5A	130A	130A	400A	240RT	
CT	S	Z	MP-B	TER	REFRIGERANT

1	1M-2MS	MAGNETIC CONTACTOR	
2	1M-R-2M-R	MAGNETIC CONTACTOR	
3	S-B	NOLOD BASED CIRCUIT BREAKER	
4	NFB2	NO FUSE BREAKER	
5	TR	TRANSFORMER	500VA
6	FPB	EMERGENCY STOP SWITCH	
7	MP	MOTOR PROTECT RELAY	
8	MP-B	MOTOR PROTECT RELAY	
9	MPR	ELECTRONIC MOTOR PROTECTOR RELAY	ECOR-SS
10	MPR-B	ELECTRONIC MOTOR PROTECTOR RELAY	ECOR-SS
11	TR	AMPERE TRANSDUCER	
12	TR-B	AMPERE TRANSDUCER	
13	CT	CURRENT TRANSFORMER	
14	CT-B	CURRENT TRANSFORMER	
15	FAN	COOLING FAN	
16	KA1-3	AUXILIARY CONTACT	FROM CONTROL PNL
17	KA1B-3B	AUXILIARY CONTACT	FROM CONTROL PNL
18	HT	OIL HEATER	
19	HT-B	OIL HEATER	
20	KT1X2	AUXILIARY	

Securing service space

- 1) Before installation, provide enough space for the service and maintenance as indicated on the foundation drawing.
This is the minimum required space for the maintenance.
- 2) The foundation to install the chiller unit should be of sufficient strength and mass to support the chiller operating weight.
- 3) Prepare a good drainage path to drain out the chilled water and cooling water when cleaning the heat exchanger tubes or before shutting down.
- 4) To ensure stable operation of the chiller, level the chiller by adjusting the level plate within 1/16"
- 5) Floor foundation construction is out of scope of LG Electronics. Please work according to the approved foundation drawings.
LG Electronics is not responsible for any unit failure caused by the inappropriate design and construction of the foundation.

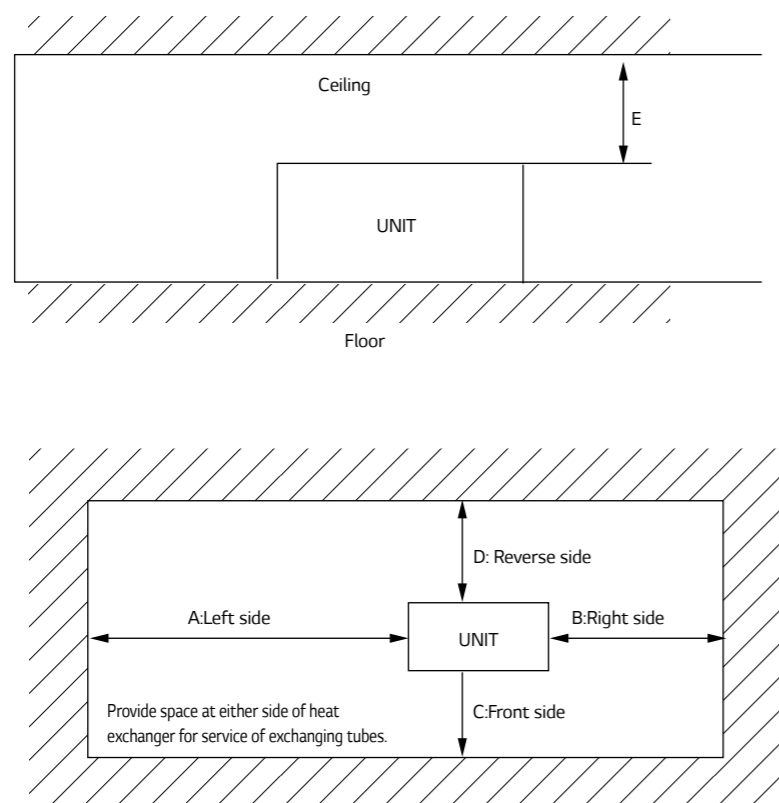

Figure 4. Minimum space requirement for installation

Model	A	B	C	D	E
RCWW008CA11 - RCWW018CA11	2,500	1,500	1,500	1,500	1,000
RCWW020CA21 - RCWW040CA21	3,100	1,500	1,500	1,500	1,000

Guide specification

Contents

Part 1 - General

- 1.01 Scope
- 1.02 System descriptions
- 1.03 Quality assurance
- 1.04 Delivery and handling

Part 2 - Products

- 2.01 General
- 2.02 Equipment description
- 2.03 Operating characteristics
- 2.04 Compressor
- 2.05 Heat exchanger
- 2.06 Expansion unit
- 2.07 Controller
- 2.08 Characteristics of the controller
- 2.09 Automatic safety device
- 2.10 Accessories and options

Part 3 - Execution

- 3.01 Installation

Part 1 – General

1.01 Scope

The requirements of the General Conditions, Supplementary Conditions and Drawings apply to all work herein.

1.02 System descriptions

Microprocessor controlled water-cooled liquid chiller utilizing screw compressor(s) and electronic expansion valves.

1.03 Quality assurance

- AHRI 550/590 - water chilling packages using the vapor compression cycle.
- ANSI/ASHRAE 34 - number designation and safety classification of refrigerants.
- ASME Section VIII - boiler and pressure vessel.
- GB/T 18430.1 - water chilling(heat pump) packages using the vapor compression cycle - part 1: water chilling(heat pump) packages for industrial & commercial and similar applications.
- GB25131 - Safety requirements for water chillers(heat pump) using the vapor compression cycle.
- GB150/151 - steel pressure vessels / Tubular heat exchangers.
- ANSI/ASHRAE Standard 15 safety code.
- Manufactured in an EN ISO 9001 accredited organization.

- The packaged chiller shall be pressure and leak test.
- Chiller manufacturer shall have factory trained and supported service organization local to the chiller installation to provide commissioning and service support throughout the manufacturer's warranty period.
- Manufacturer shall warrant all equipment and material of its supply against defects in workmanship and material for a period of eighteen(18) months from date of shipment or twelve(12) months from initial start-up, whichever occurs first.

1.04 Delivery and handling

Depending on the condition of the installation site, chiller is shipped as a single unit or as separated unit, and as charged with refrigerant or with nitrogen. If shipped as separated units, contact the authorized LG Electronics dealers or LG Electronics directly. For single unit type, the unit will be delivered to the site as preassembled. Separated unit type will be delivered as 2 or 3 separated main pieces. Confirm and record that it is the correct unit and that it is properly equipped as the submitted packing list. When refrigerant is charged, refrigerant and oil are charged together according to the specification of the chiller unit. It needs special attention to high pressure inside since the saturated refrigerant pressure is decided by the external air temperature. When nitrogen is charged, the unit

is charged with 0.5kg/cm² before shipment from the factory. If the pressure is "0", please record the condition and check for any leakage, since there is leak possibility.

Unit shall be handled, transported and stored in accordance with manufacturer's instructions.

Shipping: Unit shall ship in one piece and shall require installer to provide the evaporator and condenser inlet and outlet pipe connections. If providing chiller model that ships in multiple pieces, bid shall include all the material and field labor costs for factory authorized personnel to connect the pieces as well as all interconnecting piping and wiring.

Part 2 – Products

2.01 General

The equipment shown on the drawings is based on the model RCWW and MCWW series water cooled liquid chiller as manufactured by the LG Electronics.

2.02 Equipment description

Supply and install and commission as shown on the drawings and schedules complete factory assembled, charged and operationally tested air cooled screw compressor chiller(s) as specified herein. Chiller shall include one or more independent refrigeration circuits, semi hermetic twin screw compressors(s), shell and tube liquid cooler & condenser, Refrigerant R-134a, lubrication system and oil, interconnecting piping and wiring and lockable control center housing safety, operating and capacity controls necessary for the safe automatic operation of the liquid chiller.

2.03 Operating characteristics

- Chiller will be installed in an indoor location and shall be capable of operating in room temperatures between 4.4°C and 15.6°C(40F-60F)
- Provide capacity control system capable of reducing unit capacity to min. 25% of full load.

2.04 Compressor

The semi-hermetic twin screw compressor with precision machined cast iron housing and discharge shutoff valve. Compressor motor is cooled down by refrigerants. The differential pressure type oil lubrication and a filter-integrated type should be used. A compressor integrated type oil separator is used, a check valve should be installed at the discharge side to prevent the backward flowing of the refrigerants. Design working pressure of entire compressor, suction to discharge shall be 30 bar(435 psig) 4-step or stepless control that can control the capacity from 25 % to 100 % using a capacity control slide valve. A discharge/suction shut-off valve is installed.

To separate the oil from the refrigerant in which oil is mixed together, the internal oil separator is designed to allow the oil flow into the system to the minimum.

2.05 Heat exchanger

| Falling Film Type |

Evaporator shall be of the falling film shell and tube type with removable heads and mechanically cleanable tubes of seamless copper with internally and externally enhanced surface. Distributer located on the top side of inside shell, this makes uniform flow of refrigerant. Through distributor refrigerant flows downward by gravity as a continuous film. Tubes shall be mechanically expanded into multiple grooves in tube sheets. Cooler will incorporate one, two independent refrigerant circuits with a common chilled liquid multi-pass circuit arrangement. Coolers will be factory insulated with 19mm(optional 38) closed cell insulation with all joints vapor sealed and water drain and vent taps in cooler heads.

| Condenser |

The shall is manufactured Shell & Tube and shell be constructed and tested in accordance with pressure vessel code for a refrigerant and 10bar(150 psig) water-side pressure. To increase efficiency, sub-cooler is installed for over-cooling of condenser liquid refrigerant.

2.06 Expansion unit

Expansion unit consists of butterfly valve and orifice. At 100% load situation, the pressure loss at the orifice is smaller than the refrigerant pressure loss in the condenser, thus the super-cooled refrigerant passes through the orifice. At this stage the maximum amount of refrigerant is flowing into the evaporator. As the load reduces gradually, the circulating amount of refrigerant also reduces and accordingly the refrigerant level in the condenser is getting low. When the amount of liquid refrigerant reduces, the gas amount in the orifice is getting larger, raising the resistance thus controlling the flow rate.

| Refrigerant isolation v/v: Option |

Refrigerant isolation valves shall be provided to isolate the referent into the condenser for standard water chilling application.

2.07 Controller

| Composition of the control panel |

The control panel is composed of a Micom module(a main module, an I/O module, a display and an operation key module), a power supply unit that provides stable power, and a breaker that performs other control jobs or ensures safety, magnetic contact, and a relay for control. The major functions of these modules are as follows.

| Main module |

A high-performance microprocessor is installed in the main module and performs the control function optimized to equipment. A high-precision analog/digital converter measures sensor values in real time and displays them on the screen or applies them for the equipment control. In addition, the RS-485/232C communication port is integrated to support customers' remote monitoring. Customers can select RS-485 or RS-232C with simple operation. Therefore, It can be responded to the building automation easily.

| Display and operation key module |

The display and operation key module is composed of setting values needed for various operation data and equipment operation, a display unit that displays the malfunction information in texts, a key input unit that enables operators to input data or select menus, and a LED lamp display unit. In particular, the convenience for operators is enhanced by allowing them to use keys directly, if keys are used frequently, or select menus. Operation keys are composed of four menu handling keys, three manual control value handling keys, three manual extraction pump handling keys and two run/stop keys to run or stop the equipment operation. If the operation keys are out of order, operators can handle the control valve and the refrigerant value using the text display unit and the menu selection key. In addition, the operation status(temperature, running/stopping of the neighboring device, storage) can be displayed in English, Chinese or Korean for users' convenience.

| I/O module |

The I/O module is composed of a digital input unit which checks the operational state of various switches, and a digital output unit that controls the equipment operation. In addition, a photo coupler is installed at the I/O unit to block noises. All the I/O module data can be sent and received from the main module. Therefore, the malfunction by the EMI, which can occur when the data are transmitted using a regular cable, can be prevented and high availability can be secured.

2.08 Characteristics of the controller

| Convenient management of the operation data |

The 7.1inch color LCD shows much operation information on a screen. The analog data(e.g., temperature data) can be saved for 300 times by intervals defined by customers. The data can be used to keep operation logs or to perform maintenance work. In addition, the temperature of the chilled water outlet is displayed on a graph so that customers can understand the trend of temperature changes conveniently.

| Safety controller algorithm |

The safety parts such as high and low pressure sensor,

discharge temperature, current sensor can help product operation without shutdown. This algorithm can be minimized malfunction operations without manual reset.

| Self-diagnosis and malfunction history saving |

The microcomputer monitors the equipment state when the equipment is stopped or running, and informs the state to operators using text messages, alarm lamps and buzzers. The advice function shows cause of malfunction and checking point and troubleshooting. It can be saved in USB memory with operation and malfunction history.

| Optimized artificial intelligent control algorithm |

• Flexible Startup

To prevent excessive shocks to the equipment due to any abrupt load at the time of startup, the input power will be supplied gradually.

| Advanced digital PID control |

A digital PID control together with its smooth start-up minimizes unnecessary chiller shut-downs by recognizing the optimal PID control point automatically when the chiller is started or the chiller operation mode is changed from manual to automatic, and applying the point to the control formula. Compared with existing analog controls, more stable and accurate temperature control is possible.

※A digital transmitter to show and monitor the evaporator pressure/condenser pressure/ differential oil pressure.

※A digital transmitter to show and monitor the current/voltage.

※PT 100 sensor a chilled water/Cooling water/Oil temperature PT 100 Sensor installation.

| Scheduled operation function |

Customers can conveniently run the equipment using the schedule operation function that allows customers to select Run/Stop and control temperature setting values by weekday or holiday for 11 times per day.

| Customer support function |

• Communication function for building automation, remote surveillance and control The communication function (RS232C/RS485, users can select) is integrated so that the equipment can be connected to customers' monitoring system with ease. Also, no voltage I/O is provided so that customers can run/stop the equipment or remotely monitor the important operation state using a simple electric wiring. MODBUS is basic specification, BACnet and Modem is optional.

• Help function

If a malfunction occurs, the details thereabout will be logged and operators can take measures using the help function.

• Three language support

Users can select Korean, Chinese or English languages from the operation menu.

• Pump down function

If the operation stops, the pump-down operation will be started automatically and the refrigerants will be gathered at the condenser. Therefore, the equipment can be operated cost-effectively by its improved operation stability and by preventing the liquid suction during the operation.

2.09 Automatic safety device

A double protection device that prevents reverse phase, phase loss and overcurrents is installed. Therefore, the compressor can be completely protected against external electric shocks.

Chilled water and cooling water safety device

- A chilled water pump interlock contact
- A cooling water pump interlock contact
- A chilled /cooling water flow switch: chilled /cooling water level – under 50 %.
- Chilled water temperature(low): Chilled water out temperature – under 2.5°C.
- Evaporator refrigerant temperature(low) – Refrigerant temperature – under 2.5°C.

※A run/stop signal and interlock contact of the chilled water and cooling water pump is a very important safety device that can prevent freezing and bursting and safety incidents. Therefore, make sure to connect the line in such a way that the chiller, the chilled water pump and the cooling water pump can be linked at the time of operation.

※In addition, the automatic blocking valve should be installed to prevent the water flow on the cooling water pipe of the chiller if several cooling water pipes are connected in parallel. Then, the automatic blocking valve should be operated in line with the LG control device. To link the automatic blocking valve, the valve should be opened/closed in synchronization with the cooling water pump run/stop signal provided by the control panel.

- For more details, please contact LG service center in advance.

| Chiller protection device |

- Evaporator low pressure
 - Condenser high pressure
 - Differential oil pressure
 - Low chilled water flow
 - Evaporator low temperature
 - Condenser high temperature
 - Overcurrent protection
 - Compressor overheat protection
- #### | Motor/Compressor protector |
- A reverse phase/phase loss protection relay
 - A three-phase wire-wound temperature monitoring S/W
 - A compressor discharge temperature monitoring sensor

2.10 Accessories and options

Some accessories and options supersede standard product features. All options are factory-mounted unless otherwise noted.

| Gateway |

Provides communication for Building Automation Systems, including BACnet(MS/ TP), Modbus,(Field Commissioned by BAS Manufacturer)

| General Options |

1. Flow Switch: The water flow switch comes with SPDT output function, 1.6MPa(232 psi) working pressure, -10°C to 120°C(-14°F to 248°F) with 1" NPT connection for upright mounting in horizontal pipe(This flow switch or equivalent must be furnished with each unit). Field mounted.
2. Differential Pressure Switch: 0.2-3 bar(3-45 psig) range with 1/4" NPT pressure connections.(Field Mounted by Contractor)

| Vibration Isolation(All Options Field Mounted by Contractor |
1" Deflection Spring Isolators: Level adjustable, spring and cage type isolators for mounting under the unit base rails.

| Compressor acoustic enclosure |

The compressor acoustic enclosure can be provided as a option to reduce compressor sound levels.

| Single power point connection |

For models installed with 2, 3 and 4 compressors, to minimize job site installation cost and time, single point power connection can be provided as an option about the following models. If optional single point power connection is required, terminal block connections will be supplied at the point of incoming single point connection.

| Power factor correction |

Provide equipment with power factor correction capacitors as required to maintain a displacement power factor of 95% at all load conditions.

| Double thickness insulation |

As a standard, the evaporator shell is insulated with 19mm (3/4"). As a option, it can be insulated with 38mm(1-1/2").

| NFB(Non-Fused Breaker) power disconnect switch |

A non-fused disconnect is available as a factory-installed option for all units with single point power connection units. This option is that power supply is disconnected during service & repair work as well as door interlock.

| Suction service isolation valve |

Service suction isolation valve is installed with unit for each

refrigerant circuit as a standard.

| Pressure vessel(options) |

The evaporator and condenser can be provided with either ASME or PED pressure vessel codes certification.

Part 3 – Execution

3.01 Installation

- A. General: rig and install in full accordance with manufacturer's requirements, project drawings, and contract documents.
- B. Location: locate chiller as indicated on drawings, including cleaning and service maintenance clearance per manufacturer instructions. Adjust and level chiller on support structure.
- C. Components: installing contractor shall provide and install all auxiliary devices and accessories for fully operational chiller.
- D. Electrical: coordinate electrical requirements and connections for all power feeds with electrical contractor.
- E. Controls: coordinate all control requirements and connections with controls contractor.
- F. Finish: installing contractor shall paint damaged and abraded factory finish with touch-up paint matching factory finish.

