



Base Efficiency Air Conditioner
Direct-Drive Packaged Rooftop Unit
DBC Commercial
3-5 Nominal Tons
14 SEER/ 11.5 EER



* Complete warranty details available from your local distributor or manufacturer's representative or at www.daikincomfort.com or www.daikinac.com



Our Perfect Package:

Harnessing energy-efficient performance, proven technology, and enhanced comfort for life.

Since becoming the first company in Japan to manufacture packaged air conditioning systems, in 1951, Daikin has supported comfortable indoor living based on the strengths and technologies that have led to the growth of the company becoming one of the world's largest manufacturers of HVAC products, systems and refrigerants.

Today, as a comprehensive global manufacturer of HVAC products and systems, the Daikin brand is committed to being recognized as a truly global and excellent company capable of continually creating new value for its customers. The company plans to pursue sustainable growth and foster business operations that consistently harmonize with the goals of improving indoor comfort.

The group philosophy of the company includes:

- » Creating new value continuously for customers
- » Developing world leading energy-saving technology
- » Being a flexible and dynamic organization
- » Allowing employees to be the driving force for the success of the company
- » Fostering an atmosphere of best practices, boldness, and innovation
- » Thinking and acting globally



Contents

2	Introduction	2
4	Nomenclature	4
5	Features and Benefits	5
	Applications	8
	Serviceability	8
9	Product Specifications	9
	Coil Dimensions	9
	AHRI Ratings	9
	Sound Data	9
10	Expanding Cooling Data	10
16	Electric Heater Data	16
17	Air Flow	17
19	Static Pressure	19
20	Electrical Data	20
22	Wiring Diagrams	22
24	Dimensional Data	24
25	Electrical Connections	25
	Unit Clearances	25
26	Installation	26
	Weights	26
27	Accessories	27
29	Factory Installed Options	29
30	Field Installed Options	30
30	Factory and Field Installed Options	30

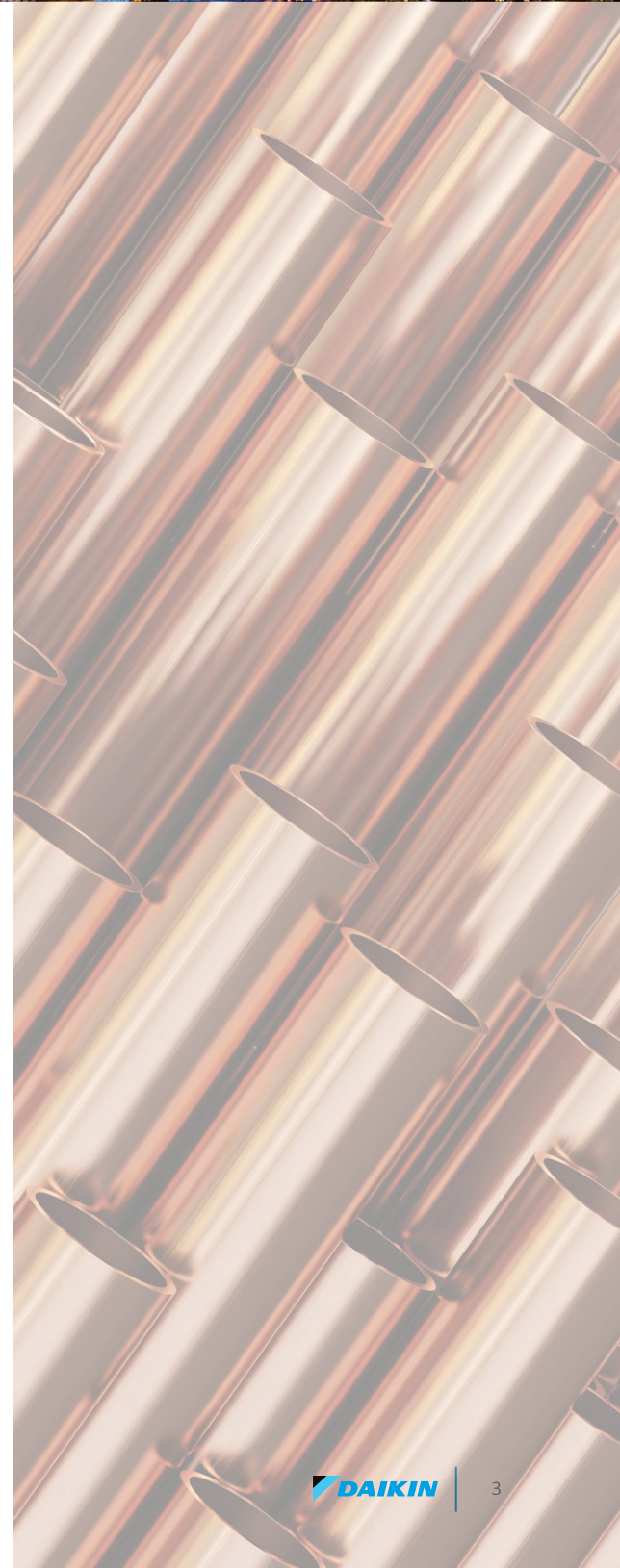

Nomenclature

	D	B	C	036	1	D	XXX	A	X	A	X	X	X	X	X	X	X	A	*																												
	1	2	3	4,5,6	7	8	9,10,11	12	13	14	15	16	17	18	19	20	21	22	23 24																												
Brand	D Daikin																																														
Configuration	B New Base Efficiency																																														
Application	C Cooling G Gas Heat H Heat Pump																																														
Nominal Cooling Capacity	036 3 Tons 048 4 Tons 060 5 Tons																																														
Voltage	1 208-230/1/60 3 208-230/3/60																																														
Supply Fan/Drive Type/Motor	D Direct-Drive- Standard Static																																														
Nominal Heating Capacity	<table border="1"> <thead> <tr> <th>Gas/Electric</th> <th>A/C</th> <th>H/P</th> <th>Factory-Installed Electric Heat</th> </tr> </thead> <tbody> <tr> <td>045 45,000 BTU/h</td> <td>XXX</td> <td>No Heat</td> <td></td> </tr> <tr> <td>070 70,000 BTU/h</td> <td>005</td> <td>5kW</td> <td></td> </tr> <tr> <td>090 90,000 BTU/h</td> <td>010</td> <td>10 kW</td> <td></td> </tr> <tr> <td>115 115,000 BTU/h</td> <td>015</td> <td>15 kW</td> <td></td> </tr> <tr> <td>140 140,000 BTU/h</td> <td>016</td> <td>15 kW</td> <td></td> </tr> <tr> <td></td> <td>022</td> <td>20 kW</td> <td></td> </tr> </tbody> </table>																			Gas/Electric	A/C	H/P	Factory-Installed Electric Heat	045 45,000 BTU/h	XXX	No Heat		070 70,000 BTU/h	005	5kW		090 90,000 BTU/h	010	10 kW		115 115,000 BTU/h	015	15 kW		140 140,000 BTU/h	016	15 kW			022	20 kW	
Gas/Electric	A/C	H/P	Factory-Installed Electric Heat																																												
045 45,000 BTU/h	XXX	No Heat																																													
070 70,000 BTU/h	005	5kW																																													
090 90,000 BTU/h	010	10 kW																																													
115 115,000 BTU/h	015	15 kW																																													
140 140,000 BTU/h	016	15 kW																																													
	022	20 kW																																													
<i>See product specifications for heat size(s) available for each capacity.</i>																																															
Refrigeration Systems	A Single-stage cooling modes																																														
Heat Exchanger	X No options A Standard Aluminized Exchanger S Stainless Steel Exchanger																																														
Controls	A Electromechanical controls																																														
Revision Levels	Major & Minor																																														
Power Exhaust	X No Options B Single-point power connection for Power Exhaust																																														
IAQ	X No Options																																														
Service Options	X No Option A Powered convenience outlet B Non-powered convenience outlet C Hinge Panels D Hinged Panels and Powered convenience outlet E Hinged Panels and non-powered convenience outlet																																														
Electrical	X No Options A Non-Fused Disconnect B Phase Monitor C Thru-the-base connections E Non-Fused Disconnect and Phase Monitor F Non-Fused Disconnect and Thru-the-base connections H Phase Monitor and Thru-the-base connections L Non-Fused Disconnect, Thru-the-base connections and Phase Monitor																																														
Economizer	X No Options A Ultra Low-Leak Downflow Economizer w/Enthalpy Sensor B Low-Leak Downflow Economizer w/Enthalpy Sensor G Ultra Low-Leak Downflow Economizer w/Dry Bulb Sensor H Low-Leak Downflow Economizer w/Dry Bulb Sensor																																														
Coils, Hail guard	X No Options C Hail Guard																																														
Sensors	X No Options A RA Smoke Detector B SA Smoke Detector C RA & SA Smoke Detector																																														

AC Stocking Models	
New Daikin 3-5 Ton Direct-Drive	
MODEL NUMBER	CODE STRING
DBC0361D000001S	DBC0361DXXXAXAXXXXXXXXXX
DBC0363D000001S	DBC0363DXXXAXAXXXXXXXXXX
DBC0481D000001S	DBC0481DXXXAXAXXXXXXXXXX
DBC0483D000001S	DBC0483DXXXAXAXXXXXXXXXX
DBC0601D000001S	DBC0601DXXXAXAXXXXXXXXXX
DBC0603D000001S	DBC0603DXXXAXAXXXXXXXXXX

Daikin Packaged Rooftop Units (RTUs) are built to perform, with features and options that help provide low installation and operation costs, superior indoor air quality, efficient operation, and longevity.

Installation

Daikin Packaged units are designed with fast and easy installation in mind and are ideal for both new construction and retrofit projects. Our packaged rooftop units are built to be a direct replacement for most rooftop units on the field without the need of a curb adapter, to be able to replace the unit in a shorter time and at a lower cost (compared to the previous design).

Cabinet Construction

Daikin packaged rooftop units are made with high quality galvanized steel with a powder-paint finish to provide higher corrosion resistance.

- » Easy accessibility using our tool-less filter access.
- » The interior surface in the indoor air section is fully insulated to prevent sweating and thermal losses, using our foil face fiberglass insulation which also omits exposed filter fibers into the airstream.
- » 1" Raised flanged edges around the supply and return offer easy installation for the duct connections.

- » The full perimeter base rail is built using heavy gauge galvanized steel for a stronger structural installation, the base rails are a minimum of 3 ½" tall and include holes to allow for overhead rigging and lifting with forklifts.
- » Electrical lines and can be brought through the base of the unit or through the horizontal knockout for easy installation and accessibility on the field.

Compressor

High performance, low noise scroll compressors to match the required total load.

- » Resiliently factory-mounted on rubber grommets for vibration isolation
- » Refrigeration circuit includes both a low- and high-pressure transducer, high pressure safety switch and temperature sensors for the suction and discharge.
- » Unit is factory charged with environmentally friendly R-410A refrigerant.
- » Single-stage scroll compressors.
- » Compressor location outside the condenser section to avoid air bypass.
- » Internal overload protection included with compressor.

Supply Fan

The Direct-Drive airfoil single width, single inlet (SWSI) Class II construction supply fan with aluminum fan blades provides efficient and quiet operation at wide ranging static pressure and air flow requirements.

- » Fan wheel is continuously welded to the hub plate and end rim for long lasting reliable operation.
- » Direct-Drive EEM motor removes the need for belts, sheaves, or bearings and its permanently lubricated motors provides low maintenance cost.
- » Each fan assembly is dynamically trim balanced at the factory before shipment for quick start-up and efficient operation.
- » Electromechanical integrated controls modulate the supply fan motor
- » Motor with thermal overload and phase failure protection is provided for motor long lasting operation.



Coils

All units use large face area outdoor coils. These coils are constructed with seamless copper tubes, mechanically bonded into aluminum plate-type fins with full drawn collars to completely cover the tubes for high operating efficiencies.

The indoor coil section is installed in a draw through configuration to provide better dehumidification.

- » Coils are factory pressure tested to ensure pressure and leak integrity.
- » Copper tube / aluminum fin coils on condenser and evaporator
- » 5mm Smart Coil Technology on all condenser coils for improved performance and reduced refrigerant load.

Controls and Wiring

Packaged rooftop units come equipped with a well-organized, large, easy to use weatherproof internal control box with easy access, for a better user experience.

- » Units are factory-wired with labeled color-coded wires and complete 24-volt Electromechanical controls package.
- » Units include single-point power entry as standard and also available with electric heat kits if selected.
- » Terminal blocks are provided as standard for easy installation and field power wiring

Filtration

Unit provides a draw-through filter section as standard for better air quality and long lasting component maintenance.

- » Filters installed on the units are standard off the shelf sizes for easy replacement.
- » One or two size filter per unit for low maintenance cost and easy replacement.
- » Easy and fast filter service access.

Heating Section

Wide ranging of electric heat selections effectively handle most comfort heating demand from morning warm-up control to full heat.

Electric Heat

ETL approved electric heat is factory assembled, installed and tested.

- » Heating control is fully integrated into the unit's control system for quick start-up and reliable control.
- » Durable low watt density, nickel chromium elements provide longer life (compared to units without).
- » Fuses are provided in each branch circuit to a maximum of 48 Amps per NEC requirements.
- » Single-point power connection reduces installation cost.
- » For operational safeties electric heat includes automatic reset, and high temperature limit safety protection and an airflow safety switch to prevent electric heat operation in the event of no airflow.

Electrical

Units are completely wired and tested at the factory to provide faster commissioning and start-up.

- » Wiring complies with NEC requirements and all applicable UL standards.
- » For ease of use, wiring and electrical components are number coded and labeled according to the electrical diagram.
- » A 120 V GFI convenience receptacle requiring independent power supply for the receptacle is optional.
- » An optional unit powered 20 amp 115 V convenience receptacle, complete with factory mounted transformer, disconnect switch, and primary and secondary overload protection, eliminates the need to pull a separate 115 V power source.
- » Supply air fan, compressor, and condenser fan motor branch circuits have individual short circuit protection. Unit includes knockouts in the bottom of the main control panels for field wiring entrance.
- » A single-point power connection with power block is standard and a terminal board is provided for connecting low voltage control wiring.
- » For better serviceability an optional non-fused disconnect switch can be installed inside the control panel and operated by an externally mounted handle to disconnect the electrical power at the unit



Applications

Daikin Rooftop units are intended for comfort cooling applications in normal heating, ventilating, and air conditioning. Consult your local Daikin sales representative for applications involving operations at high ambient temperatures, high altitudes, non-cataloged voltages, or for job-specific unit selections that fall outside of the range of the catalog tables.

For proper operation, units should be rigged in accordance with instructions stated on the installation manual. Fire dampers, if required, must be installed in the ductwork according to local and/or state codes. No space is allowed for these dampers in the unit.

Follow factory check, test and start procedures explicitly to achieve satisfactory start-up and operation.

Most rooftop applications take advantage of the significant energy savings provided with economizer operation. When an economizer system is used, mechanical refrigeration is typically not required below an ambient temperature of 50°F.

Serviceability

Daikin packaged rooftop units are built with serviceability in mind, designed to make future maintenance and service on the unit easy and accessible.

- » Our packaged rooftop units offer a slide out blower to facilitate the access and removal of the fan.
- » Filter panels on the small chassis line offer tool-less access for easy maintenance.
- » Independent compressor outside of the air bypass to eliminate component blockage and provide easy access.
- » Labeled field connections, color coded and continuously marked wire to identify point-to-point component connections.
- » All 3 - 5 ton units are designed for convertible airflow orientation to serve downflow or horizontal applications. Every unit ships prepared to convert to horizontal orientation in the field if required.
- » Condenser clean out from inside-out.
- » Easy access to gas valves and control panel.



Model	DBC0361D000001S	DBC0363D000001S	DBC0481D000001S	DBC0483D000001S	DBC0601D000001S	DBC0603D000001S
COOLING CAPACITY						
Total, BTU/h	35,000	35,000	46,500	46,500	57,000	57,000
SEER / EER	14.0/11.5	14.0/11.5	14.0/11.5	14.0/11.5	14.0/11.5	14.0/11.5
AHRI Reference #	205301890	205301891	205301892	205301893	205301894	205301895
EVAPORATOR MOTOR / COIL						
Motor Type	Direct-Drive	Direct-Drive	Direct-Drive	Direct-Drive	Direct-Drive	Direct-Drive
External Static Pressure (ESP)	Standard	Standard	Standard	Standard	Standard	Standard
Wheel Dia. X Width	12x11	12x11	12 x 11	12 x 11	12 x 11	12 x 11
Indoor Nominal CFM	1160	1160	1470	1470	1640	1640
RPM	1200	1200	1200	1200	1200	1200
Indoor Horsepower	0.75	0.75	1.0	1.0	1.0	1.0
Filter Size (in)	20 X 25 X 2 (2)	20 X 25 X 2 (2)	20 X 25 X 2 (2)	20 X 25 X 2 (2)	20 X 25 X 2 (2)	20 X 25 X 2 (2)
Drain Size (NPT)	¾	¾	¾	¾	¾	¾
R-410A Refrigerant Charge (oz.)	99	99	108	108	111	111
Evaporator Coil Face Area (ft²)	6.4	6.4	6.4	6.4	6.4	6.4
Rows Deep/ Fins per Inch	4 / 16	4 / 16	4 / 16	4 / 16	4 / 16	4 / 16
CONDENSER FAN/COIL						
Quantity of Condenser Fan Motors	1	1	1	1	1	1
RPM (High/Low stage)	810	810	1075	1075	1122	1122
Outdoor Horsepower	0.17	0.17	0.25	0.25	0.33	0.33
Fan Diameter/ # Fan Blades	22 / 3	22 / 3	22 / 4	22 / 4	22 / 3	22 / 3
Face Area (ft²)	12.5	12.5	13.3	13.3	17.1	17.1
Rows Deep / Fins per Inch	2 / 28	2 / 28	2 / 28	2 / 28	2 / 28	2 / 28
COMPRESSOR (ALL SINGLE-STAGE)						
Quantity / Type / Stages	1 / Scroll / 1	1 / Scroll / 1	1 / Scroll / 1	1 / Scroll / 1	1 / Scroll / 1	1 / Scroll / 1
Compressor RLA / LRA	16.7 / 79.0	10.4 / 73.0	19.9 / 109.0	13.1 / 83.1	25.0 / 134.0	15.9 / 110.0
ELECTRICAL DATA						
Voltage-Phase-Frequency	208/230-1-60	208/230-3-60	208/230-1-60	208/230-3-60	208/230-1-60	208/230-3-60
Indoor Blower FLA	5.7	5.7	6.9	6.9	6.9	6.9
Max External Static (In. W.C.)	0.8	0.8	0.8	0.8	0.8	0.8
Outdoor Fan FLA	0.95	0.95	1.4	1.4	2.0	2.0
Min. Circuit Ampacity ¹	27.5 / 27.5	19.7 / 19.7	33.1 / 33.1	24.7 / 24.7	40.1 / 40.1	28.8 / 28.8
Max. Overcurrent Protection (A) ²	40 / 40	30 / 30	50 / 50	35 / 35	60 / 60	40 / 40
Power Supply Conduit Hole Dia. (in)	1.125	1.125	1.125	1.125	1.125	1.125
Low-Voltage Conduit Hole Dia. (in)	0.5	0.5	0.5	0.5	0.5	0.5
OPERATING WEIGHT (LBS.)						
Operating Weight (lbs)	528	528	558	558	566	566
SHIPPING WEIGHT (LBS.)						
Ship Weight (lbs)	568	568	598	598	609	609

¹ Wire size should be determined in accordance with National Electrical Codes. Extensive wire runs will require larger wire sizes.

² May use fuses or HACR-type circuit breakers of the same size as noted.

Note: Always check the S&R plate for electrical data on the unit being installed.

Coil Dimensions

Model	Tons	Fin height in.	Fin length in.
DBC	3	24.25	38.07
	4	24.25	38.07
	5	24.25	38.07

AHRI Ratings

MODEL	CAPACITY	EER	SEER
DBC0361D	35,000	11.5	14
DBC0481D	46,500	11.5	14
DBC0601D	57,000	11.5	14
DBC0363D	35,000	11.5	14
DBC0483D	46,500	11.5	14
DBC0603D	57,000	11.5	14

Sound Data

Model	OUTDOOR SOUND (DB) AT 60 HZ								
	A-Weighted	63	125	250	500	1000	2000	4000	8000
036	75	78.5	85.4	74.4	71.8	69.1	65.8	60.9	59.2
048	73	82.5	78.1	71.6	69.5	68.0	66.1	59.5	58.6
060	76	84.4	80.5	76.2	72.9	70.9	67.4	63.8	63.1

Notes:

¹ Outdoor sound data is measured in accordance with AHRI standard 270.

² Measurements are expressed in terms of sound power. Do not compare these values to sound pressure values because sound pressure depends on specific environment factors which normally do not match individual applications. Sound power values are independent of the environment and therefore more accurate.

³ A-weighted sound ratings filter out high and very low frequencies, to better approximate the response of "average" human ear. A-weighted measurements for Daikin units are taken in accordance with AHRI standard 270.

IDB	Airflow	Outdoor Ambient Temperature																																			
		65						75						85						95						105						115					
		IDB	WB	59	63	67	71	IDB	WB	59	63	67	71	IDB	WB	59	63	67	71	IDB	WB	59	63	67	71	IDB	WB	59	63	67	71	IDB	WB	59	63	67	71
70	900	Capacity	35,125	35,628	36,692	-	34,806	35,309	36,373	-	33,876	34,379	35,443	-	32,277	32,780	33,843	-	30,322	30,825	31,888	-	28,537	29,040	30,103	-											
		S/T	0.49	0.41	0.27	-	0.49	0.42	0.28	-	0.52	0.44	0.30	-	1.00	0.46	0.32	-	1.00	0.48	0.35	-	1.00	0.53	0.40	-											
		Evap dT	22.74	20.81	17.21	-	22.69	20.76	17.16	-	22.96	21.03	17.43	-	22.67	20.74	17.14	-	22.41	20.48	16.88	-	23.62	21.69	18.09	-											
		Pr Suc	124	125	129	-	131	133	136	-	138	140	143	-	144	145	149	-	149	151	154	-	156	158	161	-											
		Pr Dis	254	255	257	-	295	296	297	-	337	338	340	-	383	384	386	-	432	433	435	-	485	486	488	-											
	TotalPower	2,092	2,089	2,085	-	2,369	2,367	2,362	-	2,678	2,676	2,671	-	3,013	3,010	3,006	-	3,386	3,384	3,380	-	3,825	3,823	3,818	-												
	Capacity	36,076	36,579	37,643	-	35,758	36,260	37,324	-	34,828	35,331	36,394	-	33,228	33,731	34,795	-	31,273	31,776	32,839	-	29,488	29,991	31,055	-												
	S/T	0.67	0.59	0.45	-	0.67	0.60	0.46	-	0.70	0.62	0.49	-	1.00	0.64	0.51	-	1.00	0.66	0.53	-	1.00	0.71	0.58	-												
	Evap dT	19.69	17.76	14.16	-	19.64	17.71	14.11	-	19.91	17.98	14.38	-	19.62	17.69	14.09	-	19.36	17.43	13.83	-	20.57	18.64	15.04	-												
	Pr Suc	128	129	133	-	136	137	140	-	142	144	147	-	148	149	153	-	153	155	158	-	160	162	165	-												
Pr Dis	259	260	262	-	300	301	303	-	342	343	345	-	388	389	391	-	437	438	440	-	490	491	493	-													
TotalPower	2,129	2,127	2,122	-	2,406	2,404	2,399	-	2,716	2,713	2,709	-	3,050	3,048	3,043	-	3,424	3,422	3,417	-	3,863	3,861	3,856	-													
Capacity	36,424	36,927	37,990	-	36,105	36,608	37,672	-	35,175	35,678	36,742	-	33,575	34,078	35,142	-	31,620	32,123	33,187	-	29,835	30,338	31,402	-													
S/T	0.69	0.61	0.48	-	0.70	0.62	0.49	-	1.00	0.65	0.51	-	1.00	0.67	0.53	-	1.00	0.69	0.55	-	1.00	0.74	0.60	-													
Evap dT	19.05	17.12	13.52	-	19.00	17.07	13.47	-	19.27	17.34	13.74	-	18.98	17.05	13.45	-	18.72	16.79	13.19	-	19.93	18.00	14.40	-													
Pr Suc	129	131	134	-	137	138	142	-	144	145	148	-	149	151	154	-	155	156	160	-	162	163	167	-													
Pr Dis	261	262	263	-	301	302	304	-	344	345	347	-	389	390	392	-	439	440	442	-	491	492	494	-													
TotalPower	2,137	2,135	2,130	-	2,414	2,412	2,407	-	2,724	2,721	2,717	-	3,058	3,056	3,051	-	3,432	3,430	3,425	-	3,871	3,869	3,864	-													
75	900	Capacity	35,146	35,649	36,712	38,337	34,827	35,330	36,394	38,019	33,897	34,400	35,464	37,089	32,297	32,800	33,864	35,489	30,342	30,845	31,909	33,534	28,557	29,060	30,124	31,749											
		S/T	0.61	0.54	0.40	0.26	0.62	0.54	0.41	0.27	1.00	0.57	0.43	0.29	1.00	0.59	0.45	0.31	1.00	0.61	0.48	0.33	1.00	1.00	0.53	0.38											
		Evap dT	26.99	25.06	21.45	17.72	26.93	25.00	21.40	17.67	27.20	25.27	21.67	17.94	26.91	24.98	21.38	17.65	26.65	24.73	21.12	17.39	27.86	25.93	22.33	18.60											
		Pr Suc	124	125	129	134	132	133	136	142	138	140	143	148	144	145	149	154	149	149	151	154	160	156	158	161	167										
		Pr Dis	254	255	257	262	295	296	298	302	337	338	340	345	383	384	386	390	432	433	435	440	485	486	488	492											
	TotalPower	2,090	2,088	2,083	2,104	2,367	2,365	2,360	2,381	2,676	2,674	2,669	2,690	3,011	3,009	3,004	3,025	3,385	3,382	3,378	3,399	3,823	3,821	3,816	3,838												
	Capacity	36,097	36,600	37,664	39,289	35,778	36,281	37,345	38,970	34,848	35,351	36,415	38,040	33,249	33,752	34,815	36,440	31,294	31,796	32,860	34,485	29,509	30,012	31,075	32,700												
	S/T	0.80	0.72	0.58	0.44	1.00	0.73	0.59	0.45	1.00	0.75	0.62	0.47	1.00	0.77	0.63	0.49	1.00	1.00	0.66	0.51	1.00	1.00	0.71	0.57												
	Evap dT	23.93	22.01	18.40	14.67	23.88	21.95	18.35	14.62	24.15	22.22	18.62	14.89	23.86	21.93	18.33	14.60	23.60	21.67	18.07	14.34	24.81	22.88	19.28	15.55												
	Pr Suc	128	129	133	138	136	137	140	146	142	144	147	152	148	150	153	158	154	155	158	164	161	162	165	171												
Pr Dis	259	261	262	267	300	301	303	307	342	344	345	350	388	389	391	396	438	439	441	445	490	491	493	498													
TotalPower	2,128	2,125	2,121	2,142	2,405	2,402	2,398	2,419	2,714	2,712	2,707	2,728	3,048	3,046	3,042	3,063	3,422	3,420	3,415	3,437	3,861	3,859	3,854	3,875													
Capacity	36,444	36,947	38,011	39,636	36,126	36,629	37,692	39,317	35,196	35,699	36,763	38,387	33,596	34,099	35,163	36,788	31,641	32,144	33,208	34,833	29,856	30,359	31,423	33,048													
S/T	0.82	0.74	0.61	0.47	1.00	0.75	0.61	0.47	1.00	0.78	0.64	0.50	1.00	0.79	0.66	0.52	1.00	1.00	0.68	0.54	1.00	1.00	0.73	0.59													
Evap dT	23.29	21.36	17.76	14.03	23.24	21.31	17.71	13.98	23.51	21.58	17.98	14.25	23.22	21.29	17.69	13.96	22.96	21.03	17.43	13.70	24.17	22.24	18.64	14.91													
Pr Suc	129	131	134	139	137	138	142	147	144	145	148	154	149	151	154	159	155	156	160	165	162	163	167	172													
Pr Dis	261	262	264	268	301	302	304	309	344	345	347	351	390	391	393	397	439	440	442	446	492	493	495	499													
TotalPower	2,135	2,133	2,129	2,150	2,412	2,410	2,406	2,427	2,722	2,720	2,715	2,736	3,056	3,054	3,049	3,071	3,430	3,428	3,423	3,445	3,869	3,867	3,862	3,883													

IDB: Entering Indoor Dry Bulb Temperature
 High and low pressures are measured at the liquid and suction access fittings.
 Design Subcooling, -16 - 19°F @ the liquid access fitting connection ARI 95 test conditions. Design Superheat 8 - 12°F @ the compressor suction access fitting connection.
 Shaded area reflects ACCA (TVA) conditions
 KW = Total system power
 Amps: Unit amps (comp.+ evaporator + condenser fan motors)

IDB	Airflow	ID WB	Outdoor Ambient Temperature																							
			65				75				85				95				105				115			
			59	63	67	71	59	63	67	71	59	63	67	71	59	63	67	71	59	63	67	71	59	63	67	71
80	900	Capacity	35,330	35,833	36,897	38,522	35,012	35,514	36,578	38,203	34,082	34,585	35,648	37,273	32,482	32,985	34,049	35,673	30,527	31,030	32,093	33,718	28,742	29,245	30,309	31,933
		S/T	1.00	0.66	0.53	0.39	1.00	0.67	0.53	0.39	1.00	0.70	0.56	0.42	1.00	1.00	0.58	0.44	1.00	1.00	0.60	0.46	1.00	1.00	0.65	0.51
		Evap dT	31.26	29.33	25.72	21.99	31.20	29.27	25.67	21.94	31.47	29.54	25.94	22.21	31.18	29.25	25.65	21.92	30.92	29.00	25.39	21.66	32.13	30.20	26.60	22.87
		Pr Suc	124	126	129	135	132	134	137	142	139	140	144	149	144	146	149	155	150	152	155	160	157	159	162	167
		Pr Dis	255	256	258	262	295	296	298	303	338	339	341	345	383	385	386	391	433	434	436	440	485	487	488	493
		TotalPower	2,091	2,089	2,084	2,106	2,368	2,366	2,361	2,383	2,678	2,675	2,671	2,692	3,012	3,010	3,005	3,026	3,386	3,384	3,379	3,400	3,825	3,823	3,818	3,839
80	1250	Capacity	36,281	36,784	37,848	39,473	35,963	36,466	37,529	39,154	35,033	35,536	36,600	38,224	33,433	33,936	35,000	36,625	31,478	31,981	33,045	34,670	29,693	30,196	31,260	32,885
		S/T	1.00	0.85	0.71	0.57	1.00	0.85	0.72	0.57	1.00	0.88	0.74	0.60	1.00	1.00	0.76	0.62	1.00	1.00	0.78	0.64	1.00	1.00	0.83	0.69
		Evap dT	28.20	26.28	22.67	18.94	28.15	26.22	22.62	18.89	28.42	26.49	22.89	19.16	28.13	26.20	22.60	18.87	27.87	25.95	22.34	18.61	29.08	27.15	23.55	19.82
		Pr Suc	128	130	133	139	136	138	141	146	143	144	148	153	149	150	153	159	154	156	159	164	161	163	166	171
		Pr Dis	260	261	263	267	300	302	303	308	343	344	346	350	389	390	392	396	438	439	441	445	491	492	494	498
		TotalPower	2,129	2,127	2,122	2,143	2,406	2,404	2,399	2,420	2,715	2,713	2,708	2,730	3,050	3,048	3,043	3,064	3,424	3,422	3,417	3,438	3,862	3,860	3,856	3,877
80	1350	Capacity	36,629	37,132	38,196	39,820	36,310	36,813	37,877	39,502	35,380	35,883	36,947	38,572	33,781	34,284	35,347	36,972	31,825	32,328	33,392	35,017	30,041	30,544	31,607	33,232
		S/T	1.00	0.87	0.73	0.59	1.00	0.88	0.74	0.60	1.00	1.00	0.77	0.62	1.00	1.00	0.78	0.64	1.00	1.00	0.81	0.66	1.00	1.00	1.00	0.72
		Evap dT	27.56	25.63	22.03	18.30	27.51	25.58	21.98	18.25	27.78	25.85	22.25	18.52	27.49	25.56	21.96	18.23	27.23	25.30	21.70	17.97	28.44	26.51	22.91	19.18
		Pr Suc	130	131	135	140	137	139	142	148	144	146	149	154	150	151	155	160	155	157	160	165	162	164	167	172
		Pr Dis	261	262	264	269	302	303	305	309	344	345	347	352	390	391	393	397	439	441	442	447	492	493	495	499
		TotalPower	2,137	2,135	2,130	2,151	2,414	2,412	2,407	2,428	2,723	2,721	2,716	2,737	3,058	3,056	3,051	3,072	3,432	3,430	3,425	3,446	3,870	3,868	3,863	3,885
85	900	Capacity	35,930	36,433	37,497	39,122	35,611	36,114	37,178	38,803	34,682	35,185	36,248	37,873	33,082	33,585	34,649	36,273	31,127	31,630	32,693	34,318	29,342	29,845	30,909	32,533
		S/T	1.00	0.77	0.63	0.49	1.00	1.00	0.64	0.49	1.00	1.00	0.66	0.52	1.00	1.00	0.68	0.54	1.00	1.00	0.70	0.56	1.00	1.00	1.00	0.61
		Evap dT	35.04	33.11	29.51	25.78	34.99	33.06	29.46	25.73	35.26	33.33	29.73	26.00	34.97	33.04	29.44	25.71	34.71	32.78	29.18	25.45	35.92	33.99	30.39	26.66
		Pr Suc	126	128	131	136	134	136	139	144	141	142	145	151	146	148	151	156	152	153	157	162	159	160	164	169
		Pr Dis	256	257	259	263	296	298	299	304	339	340	342	346	385	386	388	392	434	435	437	441	487	488	490	494
		TotalPower	2,097	2,094	2,090	2,111	2,374	2,371	2,367	2,388	2,683	2,681	2,676	2,697	3,018	3,015	3,011	3,032	3,391	3,389	3,385	3,406	3,830	3,828	3,823	3,844
85	1250	Capacity	36,881	37,384	38,448	40,073	36,563	37,066	38,129	39,754	35,633	36,136	37,200	38,824	34,033	34,536	35,600	37,225	32,078	32,581	33,645	35,270	30,293	30,796	31,860	33,485
		S/T	1.00	0.95	0.81	0.67	1.00	1.00	0.82	0.67	1.00	1.00	0.84	0.70	1.00	1.00	0.86	0.72	1.00	1.00	1.00	0.74	1.00	1.00	1.00	0.792
		Evap dT	31.99	30.06	26.46	22.73	31.94	30.01	26.41	22.68	32.21	30.28	26.68	22.95	31.92	29.99	26.39	22.66	31.66	29.73	26.13	22.40	32.87	30.94	27.34	23.61
		Pr Suc	130	132	135	140	138	140	143	148	145	146	149	155	150	152	155	161	156	158	161	166	163	165	168	173
		Pr Dis	261	262	264	269	302	303	305	309	344	345	347	352	390	391	393	397	439	440	442	447	492	493	495	499
		TotalPower	2,134	2,132	2,127	2,149	2,411	2,409	2,404	2,426	2,721	2,718	2,714	2,735	3,055	3,053	3,048	3,069	3,429	3,427	3,422	3,443	3,868	3,866	3,861	3,882
85	1350	Capacity	37,229	37,732	38,796	40,420	36,910	37,413	38,477	40,102	35,980	36,483	37,547	39,172	34,381	34,884	35,947	37,572	32,425	32,928	33,992	35,617	30,641	31,144	32,207	33,832
		S/T	1.00	0.97	0.84	0.69	1.00	1.00	0.84	0.70	1.00	1.00	0.87	0.72	1.00	1.00	0.89	0.74	1.00	1.00	1.00	0.77	1.00	1.00	1.00	0.82
		Evap dT	31.35	29.42	25.82	22.09	31.29	29.37	25.76	22.03	31.57	29.64	26.04	22.30	31.28	29.35	25.74	22.01	31.02	29.09	25.49	21.76	32.23	30.30	26.69	22.96
		Pr Suc	132	133	136	142	139	141	144	149	146	148	151	156	152	153	156	162	157	159	162	167	164	166	169	174
		Pr Dis	262	264	265	270	303	304	306	310	346	347	348	353	391	392	394	399	441	442	444	448	493	494	496	501
		TotalPower	2,142	2,140	2,135	2,156	2,419	2,417	2,412	2,434	2,728	2,726	2,722	2,743	3,063	3,061	3,056	3,077	3,437	3,435	3,430	3,451	3,876	3,874	3,869	3,890

IDB: Entering Indoor Dry Bulb Temperature
 High and low pressures are measured at the liquid and suction access fittings.
 Design Subcooling, 16 - 19 °F @ the liquid access fitting connection ARI 95 test conditions. Design Superheat 8 - 12°F @ the compressor suction access fitting connection.
 Shaded area reflects AHR1 (TVA) conditions
 kW = Total system power
 Amps: Unit amps (comp.+ evaporator + condenser fan motors)

IDB	Airflow	ID WB	Outdoor Ambient Temperature																								
			65				75				85				95				105				115				
			59	63	67	71	59	63	67	71	59	63	67	71	59	63	67	71	59	63	67	71	59	63	67	71	
		Capacity	47,073	47,742	49,155	51,314	46,650	47,318	48,731	50,890	45,415	46,083	47,496	49,655	43,289	43,957	45,371	47,529	40,692	41,360	42,773	44,932	38,320	38,989	40,402	42,561	
		S/T	0.77	0.70	0.56	0.42	1.00	0.70	0.57	0.42	1.00	0.73	0.59	0.45	1.00	0.75	0.61	0.47	1.00	1.00	0.63	0.49	1.00	1.00	0.69	0.54	
		Evap dT	30.77	28.85	25.24	21.51	30.72	28.79	25.19	21.46	30.99	29.06	25.46	21.73	30.70	28.77	25.17	21.44	30.44	28.52	24.91	21.18	31.65	29.72	26.12	22.39	
	1200	Pr Suc	122	124	127	132	130	131	135	140	137	138	141	146	142	144	147	152	148	149	152	157	154	156	159	164	
		Pr Dis	261	262	264	268	302	303	305	310	345	347	348	353	392	393	395	400	442	444	445	450	496	497	499	504	
		TotalPower	2,833	2,831	2,825	2,852	3,188	3,185	3,179	3,206	3,583	3,580	3,574	3,601	4,011	4,008	4,002	4,029	4,489	4,487	4,481	4,508	5,050	5,048	5,042	5,069	
		Capacity	48,203	48,871	50,284	52,443	47,779	48,447	49,860	52,019	46,544	47,212	48,625	50,784	44,418	45,086	46,500	48,658	41,821	42,489	43,902	46,061	39,449	40,118	41,531	43,690	
		S/T	1.00	0.85	0.71	0.57	1.00	0.85	0.72	0.57	1.00	0.88	0.74	0.60	1.00	1.00	0.76	0.62	1.00	1.00	0.78	0.64	1.00	1.00	0.83	0.69	
	80	Evap dT	28.20	26.28	22.67	18.94	28.15	26.22	22.62	18.89	28.42	26.49	22.89	19.16	28.13	26.20	22.60	18.87	27.87	25.95	22.34	18.61	29.08	27.15	23.55	19.82	
		Pr Suc	126	127	131	136	133	135	138	143	140	142	145	150	146	147	150	155	151	153	156	161	158	159	163	168	
		Pr Dis	265	266	268	273	307	308	310	314	350	351	353	358	397	398	400	404	447	448	450	455	501	502	504	508	
		TotalPower	2,874	2,871	2,865	2,892	3,228	3,226	3,219	3,247	3,624	3,621	3,615	3,642	4,052	4,049	4,043	4,070	4,530	4,527	4,521	4,548	5,091	5,088	5,082	5,109	
		Capacity	48,995	49,664	51,077	53,236	48,572	49,240	50,653	52,812	47,337	48,005	49,418	51,577	45,211	45,879	47,293	49,451	42,614	43,282	44,695	46,854	40,242	40,911	42,324	44,483	
		S/T	1.00	0.88	0.74	0.60	1.00	0.89	0.75	0.61	1.00	0.91	0.78	0.63	1.00	1.00	0.80	0.65	1.00	1.00	0.82	0.67	1.00	1.00	0.87	0.73	
	1800	Evap dT	27.17	25.24	21.64	17.91	27.12	25.19	21.59	17.86	27.39	25.46	21.86	18.13	27.10	25.17	21.57	17.84	26.84	24.91	21.31	17.58	28.05	26.12	22.52	18.79	
		Pr Suc	128	130	133	138	136	137	140	145	142	144	147	152	148	149	152	158	153	155	158	163	160	162	165	170	
		Pr Dis	268	269	271	275	309	310	312	317	352	353	355	360	399	400	402	407	449	450	452	457	503	504	506	511	
		TotalPower	2,890	2,887	2,881	2,909	3,245	3,242	3,236	3,263	3,640	3,637	3,631	3,658	4,068	4,065	4,059	4,086	4,546	4,543	4,537	4,564	5,107	5,104	5,098	5,126	
		Capacity	35,930	47,871	48,539	49,952	52,111	47,447	48,115	49,529	51,687	46,212	46,880	48,293	50,452	44,086	44,755	46,168	48,326	41,489	42,157	43,570	45,729	39,118	39,786	41,199	43,358
		1.00	1.00	0.80	0.66	0.52	1.00	0.80	0.67	0.53	1.00	1.00	0.69	0.55	1.00	1.00	0.71	0.57	1.00	1.00	0.74	0.59	1.00	1.00	1.00	0.64	
	1200	35.04	34.56	32.63	29.03	25.30	34.51	32.58	28.98	25.25	34.78	32.85	29.25	25.52	34.49	32.56	28.96	25.23	34.23	32.30	28.70	24.97	35.44	33.51	29.91	26.18	
		126	124	126	129	134	132	133	136	142	138	140	143	148	144	145	149	154	149	149	151	154	159	156	158	161	166
		256	262	263	265	269	303	304	306	311	347	348	350	354	393	394	396	401	444	445	447	451	497	499	500	505	
		2,097	2,840	2,837	2,831	2,858	3,195	3,192	3,186	3,213	3,590	3,587	3,581	3,608	4,018	4,015	4,009	4,036	4,496	4,493	4,487	4,514	5,057	5,054	5,048	5,075	
		36,881	49,000	49,668	51,081	53,240	48,576	49,244	50,658	52,816	47,341	48,009	49,422	51,581	45,215	45,884	47,297	49,456	42,618	43,286	44,699	46,858	40,247	40,915	42,328	44,487	
		1.00	1.00	0.95	0.81	0.67	1.00	1.00	0.82	0.67	1.00	1.00	0.84	0.70	1.00	1.00	0.86	0.72	1.00	1.00	0.88	0.74	1.000	1.000	1.000	0.792	
	85	31.99	31.99	30.06	26.46	22.73	31.94	30.01	26.41	22.68	32.21	30.28	26.68	22.95	31.92	29.99	26.39	22.66	31.66	29.73	26.13	22.40	32.87	30.94	27.34	23.61	
		130	128	129	132	138	135	137	140	145	142	143	147	152	147	149	152	157	153	154	158	163	160	161	164	170	
		261	266	268	269	274	308	309	311	315	351	352	354	359	398	399	401	406	448	449	451	456	502	503	505	510	
		2,134	2,881	2,878	2,872	2,899	3,235	3,232	3,226	3,253	3,631	3,628	3,622	3,649	4,059	4,056	4,050	4,077	4,537	4,534	4,528	4,555	5,098	5,095	5,089	5,116	
		37,229	49,793	50,461	51,874	54,033	49,369	50,037	51,451	53,609	48,134	48,802	50,215	52,374	46,008	46,677	48,090	50,248	43,411	44,079	45,492	47,651	41,039	41,708	43,121	45,280	
		1.00	1.00	0.98	0.85	0.70	1.00	1.00	0.85	0.71	1.00	1.00	0.88	0.73	1.00	1.00	0.90	0.75	1.00	1.00	0.88	0.74	1.00	1.00	1.00	0.83	
	1800	31.35	30.96	29.03	25.43	21.70	30.91	28.98	25.38	21.64	31.18	29.25	25.65	21.91	30.89	28.96	25.36	21.62	30.63	28.70	25.10	21.37	31.84	29.91	26.31	22.57	
		132	130	131	135	140	137	139	142	147	144	146	149	154	150	151	154	159	155	157	160	165	162	163	167	172	
		262	269	270	272	276	310	311	313	318	354	355	357	361	400	401	403	408	451	452	454	458	504	505	507	512	
		2,897	2,894	2,888	2,915	2,951	3,251	3,249	3,242	3,270	3,647	3,644	3,638	3,665	4,075	4,072	4,066	4,093	4,553	4,550	4,544	4,571	5,114	5,111	5,105	5,132	

IDB: Entering Indoor Dry Bulb Temperature
 High and low pressures are measured at the liquid and suction access fittings.
 Design Subcooling, 16 - 19 °F @ the liquid access fitting connection ARI 95 test conditions. Design Superheat 8 - 12°F @ the compressor suction access fitting connection.
 Shaded area reflects AHR1 (TVA) conditions
 kW = Total system power
 Amps: Unit amps (comp.+ evaporator + condenser fan motors)

Expanded Cooling Data

IDB	Airflow	Outdoor Ambient Temperature																																																																																																																																																																																																																																																																																																																																																																																																																																																																																																																																																																																																																																																																																																																																																																																																																																																																																																																																																																																																																																																																																																																																	
		65						75						85						95						105						115																																																																																																																																																																																																																																																																																																																																																																																																																																																																																																																																																																																																																																																																																																																																																																																																																																																																																																																																																																																																																																																																																																			
		IDB	59	63	67	71	75	IDB	59	63	67	71	75	IDB	59	63	67	71	85	IDB	59	63	67	71	95	IDB	59	63	67	71	105	IDB	59	63	67	71	115																																																																																																																																																																																																																																																																																																																																																																																																																																																																																																																																																																																																																																																																																																																																																																																																																																																																																																																																																																																																																																																																																														
Entering Indoor Wet Bulb Temperature																																																																																																																																																																																																																																																																																																																																																																																																																																																																																																																																																																																																																																																																																																																																																																																																																																																																																																																																																																																																																																																																																																																																			
	Capacity	58,154	58,973	60,705	-	57,635	58,454	60,186	-	56,120	56,939	58,672	-	53,515	54,334	56,066	-	50,331	51,150	52,882	-	47,424	48,243	49,976	-		S/T	0.60	0.53	0.39	-	0.60	0.53	0.40	-	0.63	0.56	0.42	-	0.65	0.57	0.44	-	1.00	0.60	0.46	-	1.00	0.64	0.51	-		Evap dT	20.57	18.64	15.04	-	20.52	18.59	14.99	-	20.79	18.86	15.26	-	20.50	18.57	14.97	-	20.24	18.31	14.71	-	21.45	19.52	15.92	-		Pr Suc	120	121	124	-	127	128	131	-	133	135	138	-	139	140	143	-	144	145	149	-	151	152	155	-		Pr Dis	256	257	259	-	297	298	299	-	339	340	342	-	384	385	387	-	433	435	436	-	486	487	489	-		Total Power	3,520	3,517	3,509	-	3,951	3,947	3,940	-	4,431	4,428	4,421	-	4,951	4,948	4,941	-	5,532	5,529	5,522	-	6,214	6,211	6,203	-		Capacity	58,753	59,572	61,304	-	58,234	59,053	60,785	-	56,719	57,538	59,271	-	54,114	54,933	56,665	-	50,930	51,749	53,481	-	48,023	48,842	50,575	-		S/T	0.64	0.57	0.44	-	0.65	0.57	0.44	-	0.67	0.60	0.47	-	0.69	0.62	0.49	-	1.00	0.64	0.51	-	1.00	0.69	0.56	-		Evap dT	19.69	17.76	14.16	-	19.64	17.71	14.11	-	19.91	17.98	14.38	-	19.62	17.69	14.09	-	19.36	17.43	13.83	-	20.57	18.64	15.04	-		Pr Suc	121	123	126	-	128	130	133	-	135	136	139	-	140	142	145	-	145	147	150	-	152	153	156	-		Pr Dis	258	259	261	-	298	299	301	-	341	342	343	-	386	387	389	-	435	436	438	-	487	488	490	-		Total Power	3,537	3,534	3,526	-	3,968	3,964	3,957	-	4,448	4,445	4,437	-	4,968	4,965	4,957	-	5,549	5,546	5,538	-	6,231	6,227	6,220	-		Capacity	61,857	62,676	64,409	-	61,338	62,157	63,890	-	59,824	60,643	62,375	-	57,219	58,038	59,770	-	54,035	54,854	56,586	-	51,128	51,947	53,679	-		S/T	0.68	0.60	0.47	-	0.68	0.61	0.48	-	0.71	0.63	0.50	-	1.00	0.65	0.52	-	1.00	0.67	0.54	-	1.00	0.72	0.59	-		Evap dT	17.16	15.23	11.63	-	17.11	15.18	11.58	-	17.38	15.45	11.85	-	17.09	15.16	11.56	-	16.83	14.90	11.30	-	18.04	16.11	12.51	-		Pr Suc	127	129	132	-	135	136	139	-	141	142	146	-	146	148	151	-	152	153	156	-	158	160	163	-		Pr Dis	264	265	267	-	304	306	307	-	347	348	350	-	392	393	395	-	441	442	444	-	494	495	497	-		Total Power	3,585	3,582	3,574	-	4,016	4,012	4,005	-	4,496	4,493	4,486	-	5,016	5,013	5,006	-	5,597	5,594	5,587	-	6,279	6,276	6,268	-		Capacity	58,187	59,007	60,739	63,385	57,668	58,487	60,220	62,866	56,154	56,973	58,705	61,352	53,549	54,368	56,100	58,746	50,365	51,184	52,916	55,562	47,458	48,277	50,009	52,655		S/T	0.72	0.65	0.52	0.38	0.73	0.66	0.52	0.39	1.00	0.68	0.55	0.41	1.00	0.70	0.57	0.43	1.00	0.72	0.59	0.45	1.00	0.77	0.64	0.50		Evap dT	24.81	22.88	19.28	15.55	24.76	22.83	19.23	15.50	25.03	23.10	19.50	15.77	24.74	22.81	19.21	15.48	24.48	22.55	18.95	15.22	25.69	23.76	20.16	16.43		Pr Suc	120	121	124	129	127	128	132	137	133	135	138	143	139	140	143	148	144	146	149	154	151	152	155	160		Pr Dis	256	258	259	264	297	298	300	304	339	340	342	346	385	386	388	392	434	435	437	441	486	487	489	493		Total Power	3,517	3,514	3,507	3,540	3,948	3,945	3,937	3,970	4,428	4,425	4,418	4,451	4,949	4,945	4,938	4,971	5,530	5,526	5,519	5,552	6,211	6,208	6,201	6,233		Capacity	58,787	59,606	61,338	63,984	58,267	59,087	60,819	63,465	56,753	57,572	59,305	61,951	54,148	54,967	56,699	59,345	50,964	51,783	53,515	56,161	48,057	48,876	50,608	53,255		S/T	0.76	0.69	0.56	0.42	0.77	0.70	0.57	0.43	1.00	0.72	0.59	0.45	1.00	0.74	0.61	0.47	1.00	0.76	0.63	0.49	1.00	0.81	0.68	0.54		Evap dT	23.93	22.01	18.40	14.67	23.88	21.95	18.35	14.62	24.15	22.22	18.62	14.89	23.86	21.93	18.33	14.60	23.60	21.67	18.07	14.34	24.81	22.88	19.28	15.55		Pr Suc	121	123	126	131	128	130	133	138	135	136	139	144	140	142	145	150	145	147	150	155	152	153	157	162		Pr Dis	258	259	261	265	298	300	301	306	341	342	344	348	386	387	389	394	435	436	438	443	488	489	491	495		Total Power	3,534	3,531	3,523	3,556	3,965	3,961	3,954	3,987	4,445	4,442	4,435	4,467	4,965	4,962	4,955	4,988	5,546	5,543	5,536	5,569	6,228	6,225	6,217	6,250		Capacity	61,891	62,710	64,443	67,089	61,372	62,191	63,923	66,570	59,858	60,677	62,409	65,055	57,252	58,072	59,804	62,450	54,068	54,887	56,620	59,266	51,162	51,981	53,713	56,359		S/T	0.80	0.73	0.60	0.46	1.00	0.73	0.60	0.47	1.00	0.76	0.63	0.49	1.00	0.78	0.65	0.51	1.00	0.80	0.67	0.53	1.00	1.00	0.72	0.58		Evap dT	21.40	19.47	15.87	12.14	21.35	19.42	15.82	12.08	21.62	19.69	16.09	12.36	21.33	19.40	15.80	12.07	21.07	19.14	15.54	11.81	22.28	20.35	16.75	13.02		Pr Suc	127	129	132	137	135	136	139	144	141	142	146	151	146	148	151	156	152	153	156	161	158	160	163	168		Pr Dis	264	265	267	272	305	306	308	312	347	348	350	354	392	394	395	400	442	443	444	449	494	495	497	501		Total Power	3,582	3,579	3,572	3,605	4,013	4,010	4,002	4,035	4,493	4,490	4,483	4,516	5,013	5,010	5,003	5,036	5,595	5,591	5,584	5,617	6,276	6,273	6,265	6,298		IDB: Entering Indoor Dry Bulb Temperature																										High and low pressures are measured at the liquid and suction access fittings.																										Design Subcooling, -16 - 19°F @ the liquid access fitting connection ARI 95 test conditions. Design Superheat 8 - 12°F @ the compressor suction access fitting connection.																										KW = Total system power																										Amperage: Unit amps (comp.+ evaporator + condenser fan motors)																										Shaded area reflects ACCA (TVA) conditions																								

IDB	Airflow	ID WB	Outdoor Ambient Temperature																								
			65			75			85			95			105			115									
			59	63	71	59	63	71	59	63	71	59	63	71	59	63	71	59	63	71							
80	1500	Capacity	58,488	59,307	61,039	63,685	57,969	58,788	60,520	63,166	56,454	57,274	59,006	61,652	53,849	54,668	56,401	59,047	50,665	51,484	53,217	55,863	47,758	48,577	50,310	52,956	
		S/T	0.84	0.77	0.64	0.50	1.00	0.78	0.65	0.51	1.00	0.80	0.67	0.53	1.00	0.82	0.69	0.55	1.00	1.00	0.71	0.57	1.00	1.00	0.76	0.62	
		Evap dT	29.08	27.15	23.55	19.82	29.03	27.10	23.50	19.77	29.30	27.37	23.77	20.04	29.01	27.08	23.48	19.75	28.75	26.82	23.22	19.49	29.96	28.03	24.43	20.70	
		Pr Suc	120	122	125	130	128	129	132	137	134	135	138	143	139	141	144	149	154	145	146	149	154	151	153	156	161
		Pr Dis	257	258	260	264	297	298	300	305	340	341	342	347	385	386	388	392	434	435	437	442	487	488	489	494	
		TotalPower	3,520	3,516	3,509	3,542	3,950	3,947	3,939	3,972	4,431	4,427	4,420	4,453	4,951	4,947	4,940	4,973	5,532	5,528	5,521	5,554	6,214	6,210	6,203	6,236	
80	1750	Capacity	59,087	59,906	61,638	64,285	58,568	59,387	61,119	63,765	57,054	57,873	59,605	62,251	54,448	55,267	57,000	59,646	51,264	52,083	53,816	56,462	48,357	49,176	50,909	53,555	
		S/T	0.89	0.81	0.68	0.54	1.00	0.82	0.69	0.55	1.00	0.84	0.71	0.57	1.00	0.86	0.73	0.59	1.00	1.00	0.75	0.61	1.00	1.00	0.80	0.66	
		Evap dT	28.20	26.28	22.67	18.94	28.15	26.22	22.62	18.89	28.42	26.49	22.89	19.16	28.13	26.20	22.60	18.87	27.87	25.95	22.34	18.61	29.08	27.15	23.55	19.82	
		Pr Suc	122	123	126	131	129	130	133	139	135	137	140	145	141	142	145	150	156	146	147	150	156	153	154	157	162
		Pr Dis	259	260	261	266	299	300	302	306	341	342	344	349	387	388	390	394	436	437	439	443	488	489	491	496	
		TotalPower	3,536	3,533	3,526	3,559	3,967	3,964	3,956	3,989	4,448	4,444	4,437	4,470	4,968	4,964	4,957	4,990	5,549	5,545	5,538	5,571	6,230	6,227	6,220	6,253	
80	2250	Capacity	62,192	63,011	64,743	67,389	61,672	62,492	64,224	66,870	60,158	60,977	62,710	65,356	57,553	58,372	60,104	62,750	54,369	55,188	56,920	59,566	51,462	52,281	54,013	56,660	
		S/T	1.00	0.85	0.72	0.58	1.00	0.85	0.72	0.59	1.00	0.88	0.75	0.61	1.00	1.00	0.77	0.63	1.00	1.00	0.79	0.65	1.00	1.00	0.84	0.70	
		Evap dT	25.67	23.74	20.14	16.41	25.62	23.69	20.09	16.36	25.89	23.96	20.36	16.63	25.60	23.67	20.07	16.34	25.34	23.41	19.81	16.08	26.55	24.62	21.02	17.29	
		Pr Suc	128	129	132	138	135	137	140	145	142	143	146	151	147	148	151	157	162	152	154	157	162	159	160	163	168
		Pr Dis	265	266	268	272	305	306	308	313	347	349	350	355	393	394	396	400	442	443	445	449	494	495	497	502	
		TotalPower	3,585	3,581	3,574	3,607	4,015	4,012	4,004	4,037	4,496	4,492	4,485	4,518	5,016	5,012	5,005	5,038	5,597	5,593	5,586	5,619	6,278	6,275	6,268	6,301	
85	1500	Capacity	59,465	60,284	62,016	64,663	58,946	59,765	61,497	64,143	57,432	58,251	59,983	62,629	54,826	55,645	57,378	60,024	51,642	52,461	54,194	56,840	48,735	49,555	51,287	53,933	
		S/T	1.00	0.87	0.74	0.60	1.00	0.87	0.74	0.61	1.00	1.00	0.77	0.63	1.00	1.00	0.79	0.65	1.00	1.00	0.81	0.67	1.00	1.00	0.86	0.72	
		Evap dT	32.87	30.94	27.34	23.61	32.82	30.89	27.29	23.55	33.09	31.16	27.56	23.82	32.80	30.87	27.27	23.53	32.54	30.61	27.01	23.28	33.75	31.82	28.22	24.48	
		Pr Suc	122	124	127	132	129	131	134	139	136	137	140	145	141	143	146	151	156	146	148	151	156	153	154	157	163
		Pr Dis	258	259	261	265	298	300	301	306	341	342	344	348	386	387	389	394	435	436	438	443	488	489	491	495	
		TotalPower	3,528	3,525	3,517	3,550	3,958	3,955	3,948	3,981	4,439	4,436	4,428	4,461	4,959	4,956	4,948	4,981	5,540	5,537	5,529	5,562	6,222	6,218	6,211	6,244	
85	1750	Capacity	60,064	60,883	62,616	65,262	59,545	60,364	62,096	64,743	58,031	58,850	60,582	63,228	55,425	56,244	57,977	60,623	52,241	53,060	54,793	57,439	49,335	50,154	51,886	54,532	
		S/T	1.00	0.91	0.78	0.64	1.00	0.92	0.78	0.65	1.00	1.00	0.81	0.67	1.00	1.00	0.83	0.69	1.00	1.00	0.85	0.71	1.00	1.00	0.86	0.72	
		Evap dT	31.99	30.06	26.46	22.73	31.94	30.01	26.41	22.68	32.21	30.28	26.68	22.95	31.92	29.99	26.39	22.66	31.66	29.73	26.13	22.40	32.87	30.94	27.34	23.61	
		Pr Suc	123	125	128	133	131	132	135	140	137	139	142	147	142	144	147	152	157	148	149	152	157	154	156	159	164
		Pr Dis	260	261	263	267	300	301	303	308	342	344	345	350	388	389	391	395	437	438	440	444	489	490	492	497	
		TotalPower	3,545	3,541	3,534	3,567	3,975	3,972	3,964	3,997	4,456	4,452	4,445	4,478	4,976	4,972	4,965	4,998	5,557	5,553	5,546	5,579	6,239	6,235	6,228	6,261	
85	2250	Capacity	63,169	63,988	65,720	68,366	62,650	63,469	65,201	67,847	61,135	61,954	63,687	66,333	58,530	59,349	61,081	63,728	55,346	56,165	57,897	60,544	52,439	53,258	54,991	57,637	
		S/T	1.00	0.95	0.82	0.68	1.00	1.00	0.82	0.68	1.00	1.00	0.85	0.71	1.00	1.00	0.86	0.73	1.00	1.00	0.87	0.73	1.00	1.00	0.80	0.66	
		Evap dT	29.46	27.53	23.93	20.19	29.40	27.48	23.87	20.14	29.68	27.75	24.14	20.41	29.38	27.46	23.85	20.12	29.13	27.20	23.60	19.86	30.33	28.41	24.80	21.07	
		Pr Suc	130	131	134	139	137	138	141	147	143	145	148	153	149	150	153	158	154	155	159	164	161	162	165	170	
		Pr Dis	266	267	269	273	306	307	309	314	349	350	352	356	394	395	397	401	443	444	446	451	496	497	498	503	
		TotalPower	3,593	3,590	3,582	3,615	4,023	4,020	4,013	4,046	4,504	4,501	4,493	4,526	5,024	5,021	5,013	5,046	5,605	5,602	5,594	5,627	6,287	6,283	6,276	6,309	

IDB: Entering Indoor Dry Bulb Temperature
 High and low pressures are measured at the liquid and suction access fittings.
 Design Subcooling, 16 - 19 °F @ the liquid access fitting connection ARI 95 test conditions. Design Superheat 8 - 12°F @ the compressor suction access fitting connection.

Shaded area reflects AHRl (TVA) conditions
 kW = Total system power
 Amps: Unit amps (comp.+ evaporator + condenser fan motors)

Electrical Heater Data

ELECTRIC HEATERS							
MODEL #	MIN AIRFLOW	MAX AIRFLOW	EH*D-*S05	EH*D-*S10	EH*D-*S15	EH*D-*S16	EH*D-*S22
DBC036*D	975	1350	X	X		X	
DBC048*D	1300	1800	X	X	X		X
DBC060*D	1625	2250	X	X	X		X

3 Ton AC - Downshot

SPEED TAP	EXTERNAL STATIC PRESSURE (ESP) IN W. C.	STANDARD CFM	AMPS	BHP	RPM
T1	0.2	1156	0.14	107	576
	0.4	1013	0.17	124	665
	0.6	874	0.18	138	742
	0.8	767	0.20	150	807
T2	0.2	1220	0.16	120	593
	0.4	1086	0.18	137	677
	0.6	947	0.21	153	755
	0.8	844	0.22	166	818
T3	0.2	1241	0.17	124	598
	0.4	1109	0.19	141	681
	0.6	970	0.21	157	759
	0.8	868	0.23	170	821
T4	0.2	1542	0.30	221	703
	0.4	1485	0.31	233	741
	0.6	1361	0.35	261	833
	0.8	1224	0.38	282	900
T5	0.2	1446	0.24	179	662
	0.4	1355	0.26	196	721
	0.6	1222	0.29	219	806
	0.8	1112	0.32	235	867

3 Ton AC - Horizontal

SPEED TAP	EXTERNAL STATIC PRESSURE (ESP) IN W. C.	STANDARD CFM	AMPS	BHP	RPM
T1	0.2	1179	0.15	114	613
	0.4	1034	0.18	132	707
	0.6	892	0.20	147	789
	0.8	782	0.21	160	858
T2	0.2	1245	0.17	128	630
	0.4	1108	0.20	146	720
	0.6	966	0.22	163	803
	0.8	861	0.24	177	870
T3	0.2	1266	0.18	132	636
	0.4	1132	0.20	150	724
	0.6	990	0.22	167	807
	0.8	886	0.24	181	874
T4	0.2	1574	0.31	235	748
	0.4	1515	0.33	247	788
	0.6	1389	0.37	278	886
	0.8	1249	0.40	300	957
T5	0.2	1476	0.26	191	704
	0.4	1383	0.28	208	767
	0.6	1247	0.31	233	857
	0.8	1135	0.34	250	923

4 Ton AC - Downshot

SPEED TAP	EXTERNAL STATIC PRESSURE (ESP) IN W. C.	STANDARD CFM	AMPS	BHP	RPM
T1	0.2	1374	0.24	178	660
	0.4	1256	0.27	201	744
	0.6	1136	0.29	219	810
	0.8	1022	0.31	234	869
T2	0.2	1627	0.34	257	724
	0.4	1535	0.38	285	804
	0.6	1422	0.41	309	870
	0.8	1311	0.44	328	924
T3	0.2	1505	0.29	220	704
	0.4	1403	0.33	245	785
	0.6	1286	0.36	266	851
	0.8	1172	0.38	283	907
T4	0.2	1895	0.49	366	794
	0.4	1807	0.53	397	861
	0.6	1697	0.58	431	933
	0.8	1607	0.61	453	982
T5	0.2	1723	0.39	292	749
	0.4	1635	0.43	322	825
	0.6	1524	0.47	348	892
	0.8	1418	0.49	369	945

4 Ton AC - Horizontal

SPEED TAP	EXTERNAL STATIC PRESSURE (ESP) IN W. C.	STANDARD CFM	AMPS	BHP	RPM
T1	0.2	1402	0.25	190	703
	0.4	1282	0.29	214	792
	0.6	1159	0.31	233	862
	0.8	1043	0.33	249	924
T2	0.2	1661	0.37	274	771
	0.4	1567	0.41	304	855
	0.6	1451	0.44	328	925
	0.8	1338	0.47	349	983
T3	0.2	1536	0.31	234	749
	0.4	1431	0.35	261	835
	0.6	1312	0.38	283	905
	0.8	1196	0.40	301	964
T4	0.2	1934	0.52	390	844
	0.4	1844	0.57	423	916
	0.6	1732	0.61	458	993
	0.8	1640	0.65	482	1045
T5	0.2	1758	0.42	311	797
	0.4	1669	0.46	343	878
	0.6	1555	0.50	371	949
	0.8	1447	0.53	392	1005

5 Ton AC - Downshot

SPEED TAP	EXTERNAL STATIC PRESSURE (ESP) IN W. C.	STANDARD CFM	AMPS	BHP	RPM
T1	0.2	1666	0.36	271	734
	0.4	1576	0.40	300	813
	0.6	1464	0.44	324	879
	0.8	1355	0.46	344	933
T2	0.2	1759	0.41	307	758
	0.4	1673	0.45	337	833
	0.6	1562	0.49	365	901
	0.8	1458	0.52	386	953
T3	0.2	1846	0.46	344	781
	0.4	1760	0.50	375	851
	0.6	1649	0.54	406	922
	0.8	1554	0.57	428	972
T4	0.2	2309	0.87	646	909
	0.4	2110	0.88	654	921
	0.6	1988	0.99	736	1037
	0.8	2017	1.02	759	1070
T5	0.2	2029	0.59	442	830
	0.4	1929	0.63	472	887
	0.6	1819	0.69	514	966
	0.8	1750	0.72	538	1011

5 Ton AC - Horizontal

SPEED TAP	EXTERNAL STATIC PRESSURE (ESP) IN W. C.	STANDARD CFM	AMPS	BHP	RPM
T1	0.2	1700	0.39	288	781
	0.4	1609	0.43	319	864
	0.6	1493	0.46	345	935
	0.8	1382	0.49	366	992
T2	0.2	1795	0.44	326	807
	0.4	1707	0.48	359	886
	0.6	1593	0.52	388	958
	0.8	1488	0.55	410	1014
T3	0.2	1883	0.49	366	831
	0.4	1795	0.53	399	906
	0.6	1683	0.58	432	980
	0.8	1586	0.61	455	1034
T4	0.2	2356	0.92	1028	968
	0.4	2154	0.93	1056	979
	0.6	2028	1.05	1087	1103
	0.8	2058	1.08	1109	1138
T5	0.2	2071	0.63	470	883
	0.4	1969	0.67	502	943
	0.6	1856	0.73	547	1028
	0.8	1786	0.77	573	1076

Speed Tap T1 for fan only applications

Static Pressure

3-5 TONS		
DOWNFLOW ECONOMIZER PRESSURE DROP		
Cabinet	CFM	SP in.wg.
3 Ton	900	.03"
	1200	.05"
	1500	.08"
4 Ton	1200	.06"
	1600	.10"
	2000	.14"
5 Ton	1500	.08"
	2000	.14"
	2500	.22"

3-5 TONS		
HORIZONTAL ECONOMIZER PRESSURE DROP		
Cabinet	CFM	SP in.wg.
3 Ton	900	.06"
	1200	.11"
	1500	.16"
4 Ton	1200	.11"
	1600	.19"
	2000	.29"
5 Ton	1500	.18"
	2000	.30"
	2500	.45"

Electrical Data

Model Number	Electrical Rating	Compressor			Outdoor Fan Motor			Indoor Fan Motor			Optional Electric Heat			Optional Powered Convenience Outlet	Optional Power Exhaust	Power Supply	
		QTY	RLA	LRA	QTY	HP	FLA	Type	HP	FLA	PART #	KW*	FLA	FLA	FLA	MCA	MOP
DBC0361D	208/230/1/60	1	16.67	79	1	0.17	0.95	Direct-Drive Standard Static	0.75	5.7	-	-	-	-	-	27.5/27.5	40/40
											-	-	-	9.6/8.7	-	37.1/36.2	50/50
											-	-	-	-	1.7/1.5	29.2/29.0	40/40
											-	-	-	9.6/8.7	1.7/1.5	38.8/37.7	50/50
											-	-	-	-	-	29.7/33.2	40/40
											EH*D-1S05	3.76/5.00	18.1/20.8	9.6/8.7	-	41.7/44.0	50/50
											-	-	-	-	1.7/1.5	31.8/35.0	40/40
											-	-	-	9.6/8.7	1.7/1.5	43.8/45.9	50/50
											-	-	-	-	-	52.3/59.2	60/60
											EH*D-1S10	7.51/10.0	36.1/41.7	9.6/8.7	-	64.3/70.1	70/80
											-	-	-	-	1.7/1.5	54.4/61.1	60/70
											-	-	-	9.6/8.7	1.7/1.5	66.4/72.0	70/80
DBC0363D	208/230/3/60	1	10.45	73	1	0.17	0.95	Direct-Drive Standard Static	0.75	5.7	-	-	-	-	-	19.7/19.7	30/30
											-	-	-	9.6/8.7	-	29.3/28.4	35/35
											-	-	-	-	1.7/1.5	21.4/21.2	30/30
											-	-	-	9.6/8.7	1.7/1.5	31.0/29.9	35/35
											-	-	-	-	-	20.2/22.2	30/30
											EH*D-3S05	3.76/5.00	10.4/12.0	9.6/8.7	-	32.2/33.0	35/35
											-	-	-	-	1.7/1.5	22.3/24.0	30/30
											-	-	-	9.6/8.7	1.7/1.5	34.3/34.9	35/35
											-	-	-	-	-	33.2/37.2	35/40
											EH*D-3S10	7.51/10.0	20.8/24.1	9.6/8.7	-	45.2/48.1	50/50
											-	-	-	-	1.7/1.5	35.3/39.1	40/40
											-	-	-	9.6/8.7	1.7/1.5	47.3/49.9	50/50
DBC0481D	208/230/1/60	1	19.87	109	1	0.25	1.4	Direct-Drive Standard Static	1	6.9	-	-	-	-	-	33.1/33.1	50/50
											-	-	-	9.6/8.7	-	42.7/41.8	60/60
											-	-	-	-	1.7/1.5	34.8/34.6	50/50
											-	-	-	9.6/8.7	1.7/1.5	44.4/43.3	60/60
											-	-	-	-	-	33.1/34.7	50/50
											EH*D-1S05	3.76/5.00	18.1/20.8	9.6/8.7	-	43.2/45.5	60/60
											-	-	-	-	1.7/1.5	34.8/36.5	50/50
											-	-	-	9.6/8.7	1.7/1.5	45.3/47.4	60/60
											-	-	-	-	-	53.8/60.7	60/70
											EH*D-1S10	7.51/10.0	36.1/41.7	9.6/8.7	-	65.8/71.6	70/80
											-	-	-	-	1.7/1.5	55.9/62.6	60/70
											-	-	-	9.6/8.7	1.7/1.5	67.9/73.5	70/80
DBC0481D	208/230/1/60	1	19.87	109	1	0.25	1.4	Direct-Drive Standard Static	1	6.9	-	-	-	-	-	76.3/86.8	80/90
											-	-	-	9.6/8.7	-	88.3/97.6	90/100
											-	-	-	-	1.7/1.5	78.5/88.6	80/90
											-	-	-	9.6/8.7	1.7/1.5	90.5/99.5	100/100
											-	-	-	-	-	98.9/113	100/125
											EH*D-1S22	15.0/20.0	72.2/83.3	9.6/8.7	-	111/124	125/125
-	-	-	-	1.7/1.5	101/115	110/125											
-	-	-	9.6/8.7	1.7/1.5	113/126	125/150											

Electrical Data

Model Number	Electrical Rating	Compressor			Outdoor Fan Motor			Indoor Fan Motor			Optional Electric Heat			Optional Powered Convenience Outlet	Optional Power Exhaust	Power Supply	
		QTY	RLA	LRA	QTY	HP	FLA	Type	HP	FLA	PART #	KW*	FLA	FLA	FLA	MCA	MOP
DBC0483D	208/230/3/60	1	13.14	83.1	1	0.25	1.4	Direct-Drive Standard Static	1	6.9	-	-	-	-	-	24.7/24.7	35/35
											-	-	-	9.6/8.7	-	34.3/33.4	45/45
											-	-	-	-	1.7/1.5	26.4/26.2	35/35
											-	-	-	9.6/8.7	1.7/1.5	36.0/34.9	45/45
											-	-	-	-	-	24.7/24.7	35/35
											EH*D-3S05	3.76/5.00	10.4/12.0	9.6/8.7	-	34.3/34.5	45/45
											-	-	-	-	1.7/1.5	26.4/26.2	35/35
											-	-	-	9.6/8.7	1.7/1.5	36.0/36.4	45/45
											-	-	-	-	-	34.7/38.7	35/40
											EH*D-3S10	7.51/10.0	20.8/24.1	9.6/8.7	-	46.7/49.6	50/50
											-	-	-	-	1.7/1.5	36.8/40.6	40/45
											-	-	-	9.6/8.7	1.7/1.5	48.8/51.4	50/60
											-	-	-	-	-	47.7/53.7	50/60
											EH*D-3S15	11.3/15.0	31.3/36.1	9.6/8.7	-	59.7/64.6	60/70
-	-	-	-	1.7/1.5	49.8/55.6	50/60											
-	-	-	9.6/8.7	1.7/1.5	61.8/66.5	70/70											
-	-	-	-	-	60.5/68.5	70/70											
EH*D-3S22	15.0/19.9	41.5/47.9	9.6/8.7	-	72.5/79.3	80/80											
-	-	-	-	1.7/1.5	62.6/70.3	70/80											
-	-	-	9.6/8.7	1.7/1.5	74.6/81.2	80/90											
DBC0601D	208/230/1/60	1	25.00	134	1	0.33	2	Direct-Drive Standard Static	1	6.9	-	-	-	-	-	40.1/40.1	60/60
											-	-	-	9.6/8.7	-	49.7/48.8	70/70
											-	-	-	-	1.7/1.5	41.8/41.6	60/60
											-	-	-	9.6/8.7	1.7/1.5	51.4/50.3	70/70
											-	-	-	-	-	40.1/40.1	60/60
											EH*D-1S05	3.76/5.00	18.1/20.8	9.6/8.7	-	49.7/48.8	70/70
											-	-	-	-	1.7/1.5	41.8/41.6	60/60
											-	-	-	9.6/8.7	1.7/1.5	51.4/50.3	70/70
											-	-	-	-	-	53.8/60.7	60/70
											EH*D-1S10	7.51/10.0	36.1/41.7	9.6/8.7	-	65.8/71.6	70/80
											-	-	-	-	1.7/1.5	55.9/62.6	60/70
											-	-	-	9.6/8.7	1.7/1.5	67.9/73.5	70/80
											-	-	-	-	-	76.3/86.8	80/90
											EH*D-1S15	11.3/15.0	54.2/62.5	9.6/8.7	-	88.3/97.6	90/100
-	-	-	-	1.7/1.5	78.5/88.6	80/90											
-	-	-	9.6/8.7	1.7/1.5	90.5/99.5	100/100											
-	-	-	-	-	98.9/113	100/125											
EH*D-1S22	15.0/20.0	72.2/83.3	9.6/8.7	-	111/124	125/125											
-	-	-	-	1.7/1.5	101/115	110/125											
-	-	-	9.6/8.7	1.7/1.5	113/126	125/150											
DBC0603D	208/230/3/60	1	15.90	110	1	0.33	2	Direct-Drive Standard Static	1	6.9	-	-	-	-	-	28.8/28.8	40/40
											-	-	-	9.6/8.7	-	38.4/37.5	50/50
											-	-	-	-	1.7/1.5	30.5/30.3	40/40
											-	-	-	9.6/8.7	1.7/1.5	40.1/39.0	50/50
											-	-	-	-	-	28.8/28.8	40/40
											EH*D-3S05	3.76/5.00	10.4/12.0	9.6/8.7	-	38.4/37.5	50/50
											-	-	-	-	1.7/1.5	30.5/30.3	40/40
											-	-	-	9.6/8.7	1.7/1.5	40.1/39.0	50/50
											-	-	-	-	-	34.7/38.7	40/40
											EH*D-3S10	7.51/10.0	20.8/24.1	9.6/8.7	-	46.7/49.6	50/50
											-	-	-	-	1.7/1.5	36.8/40.6	40/45
											-	-	-	9.6/8.7	1.7/1.5	48.8/51.4	50/60
											-	-	-	-	-	47.7/53.7	50/60
											EH*D-3S15	11.3/15.0	31.3/36.1	9.6/8.7	-	59.7/64.6	60/70
-	-	-	-	1.7/1.5	49.8/55.6	50/60											
-	-	-	9.6/8.7	1.7/1.5	61.8/66.5	70/70											
-	-	-	-	-	60.5/68.5	70/70											
EH*D-3S22	15.0/19.9	41.5/47.9	9.6/8.7	-	72.5/79.3	80/80											
-	-	-	-	1.7/1.5	62.6/70.3	70/80											
-	-	-	9.6/8.7	1.7/1.5	74.6/81.2	80/90											

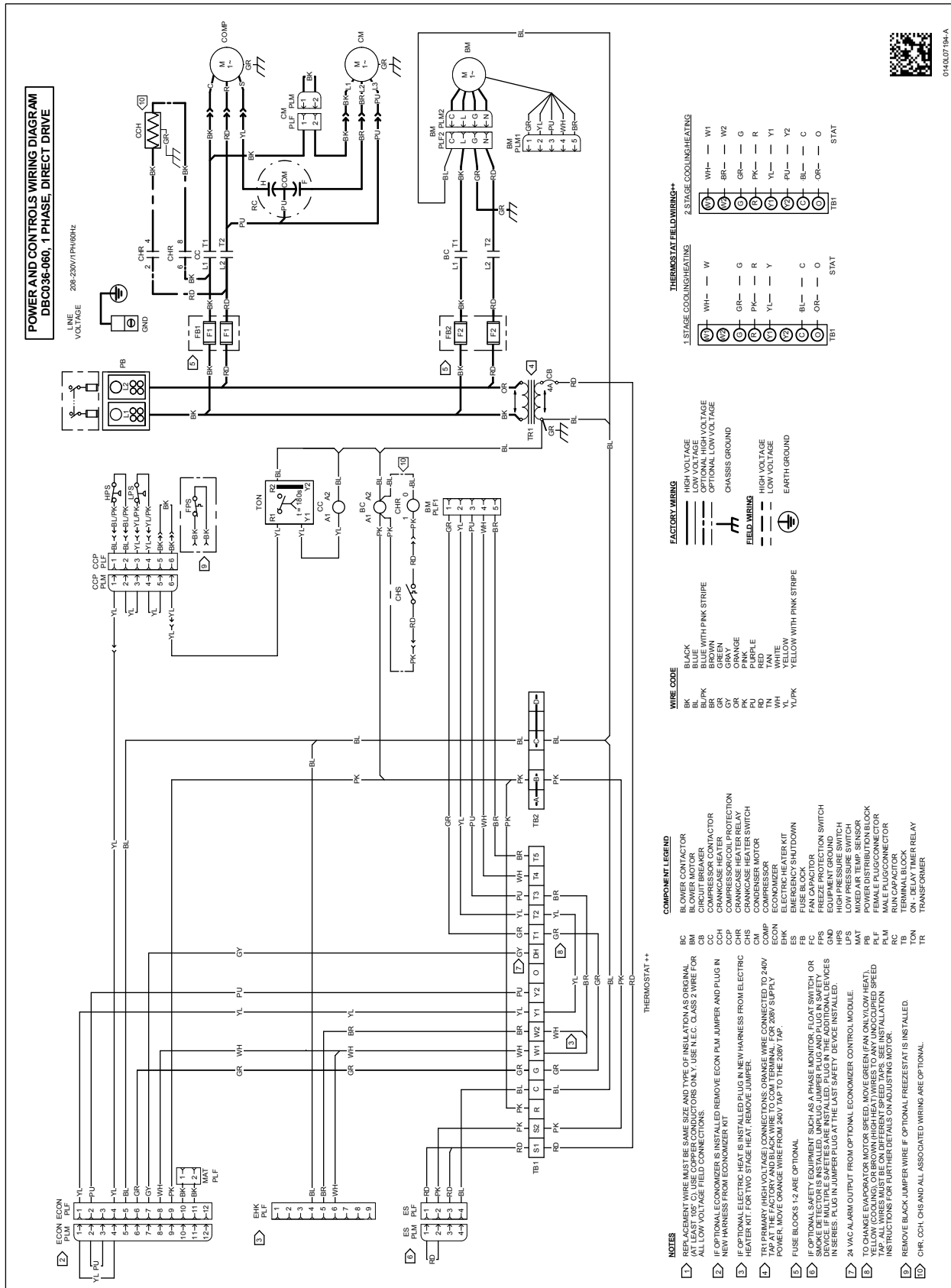

WARNING

High Voltage: Disconnect all power before servicing or installing this unit. Multiple power sources may be present. Failure to do so may cause property damage, personal injury, or death.

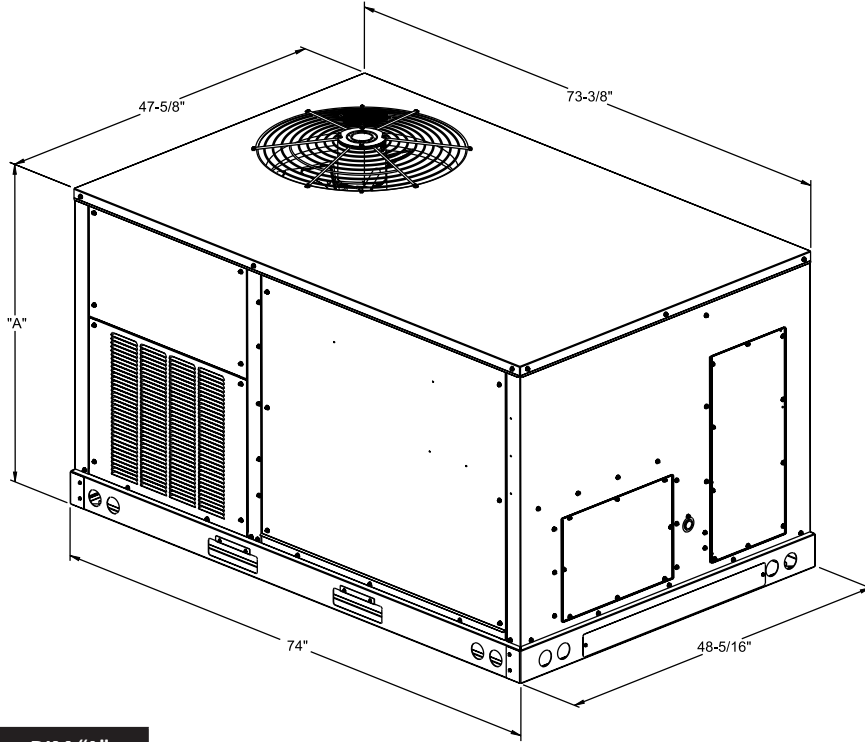

Model Size	DIM "A"
3-5 ton AC	39%

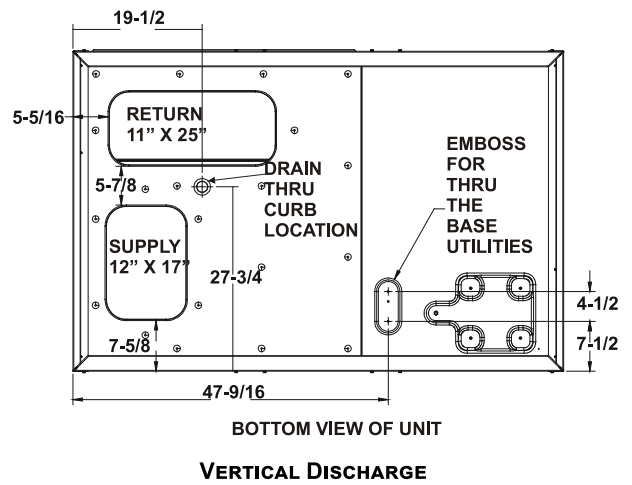
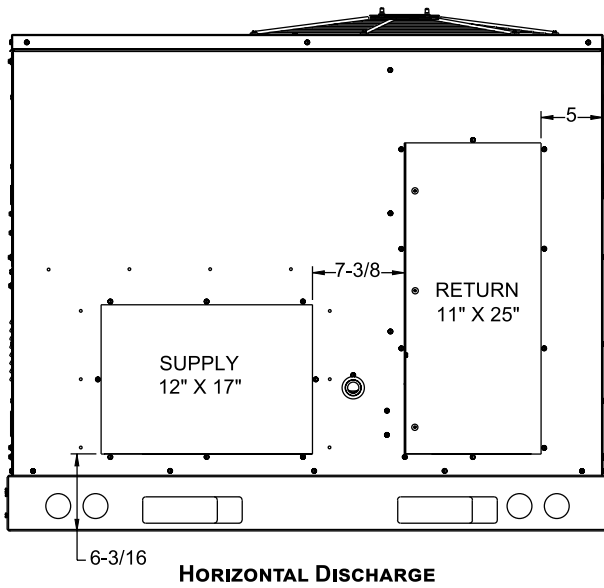

Electrical Connections

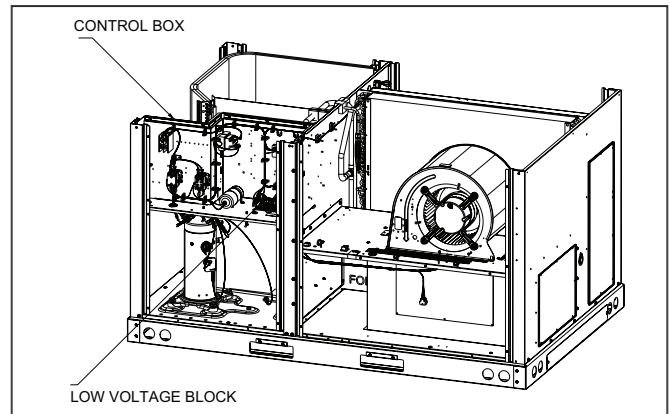
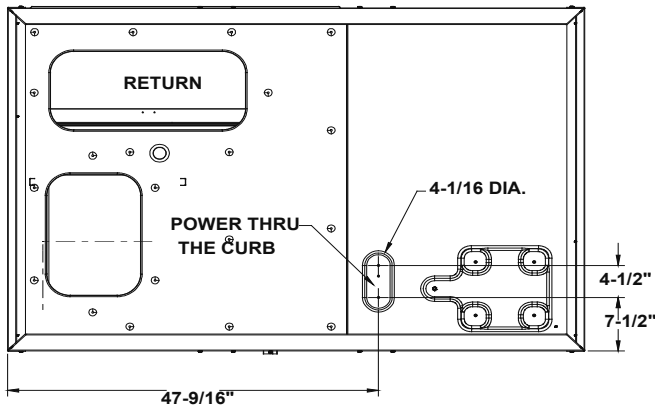
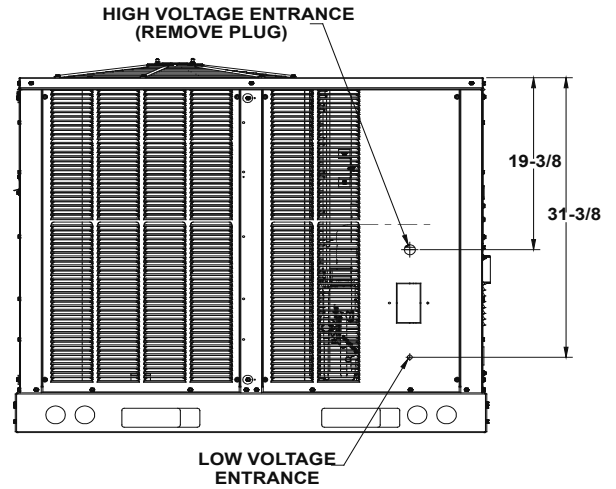
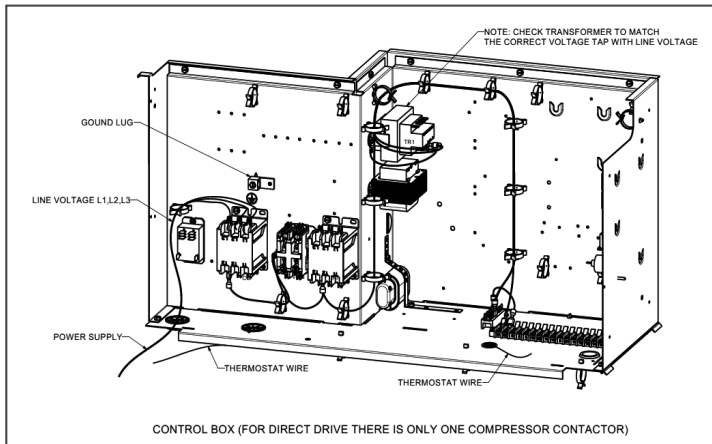

Unit Clearances

Service Clearance

Allow for recommended service clearances as shown in figure to the right. In situations that have multiple units, a 36" minimum clearance is required between the condenser coils. A clearance of 48" is recommended on all sides of the unit to allow service access and to ensure proper ventilation and condenser airflow. The top of the unit should be unobstructed. Provide a roof walkway along the sides of the unit for service and access to controls and components. Contact your Daikin sales representative for service requirements less than those recommended.

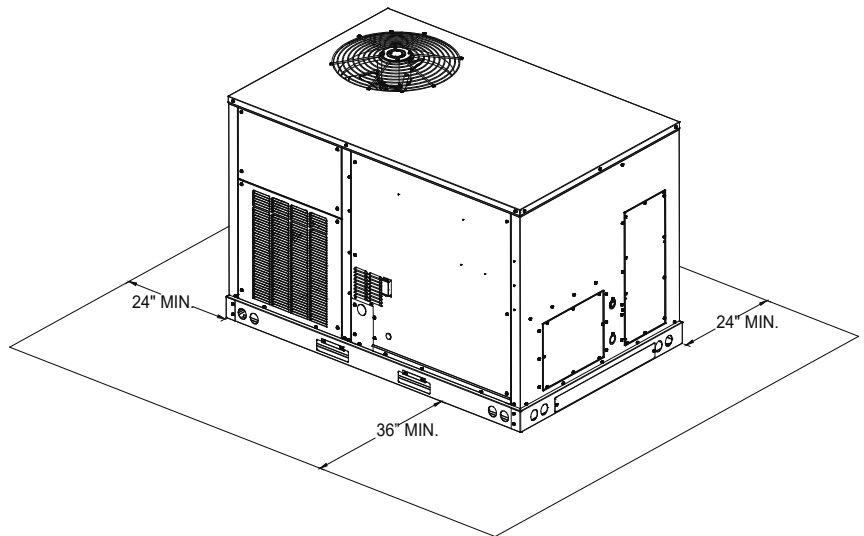

Unit Location

The structural engineer must verify that the roof has adequate support and ability to minimize deflection. Take extreme caution when using on a wooden roof structure. Unit condenser coils should be in a location that avoids any heated exhaust air.

Allow sufficient space around the unit for maintenance/service clearance. Consult your Daikin sales representative if available clearances do not meet minimum recommendations.

Where code considerations, such as the NEC, require extended clearances, these take precedence.

Provisions for forks have been included in the unit base frame. No other fork locations are approved.

- » Unit must be lifted by the four lifting holes located at the base frame corners.
- » Lifting cables should be attached to the unit with shackles.
- » The distance between the crane hook and the top of the unit must not be less than 60”.
- » Two spreader bars must span over the unit to prevent damage to the cabinet by the lift cables. Spreader bars must be of sufficient length so that cables do not come in contact with the unit during transport. Remove wood struts mounted beneath unit base

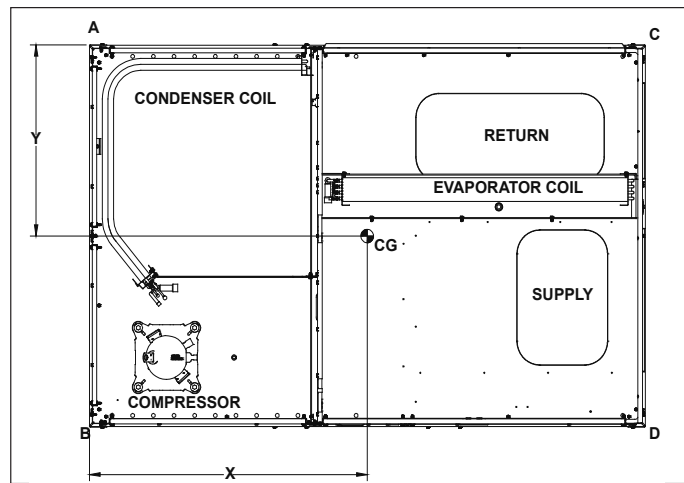

CORNER & CENTER-OF-GRAVITY LOCATIONS

frame before setting unit on roof curb. These struts are intended to protect unit base frame from forklift damage. To remove the struts, extract the sheet metal retainers and pull the struts through the base of the unit. Refer to rigging label on the unit.

Important: If using bottom discharge with roof curb, ductwork should be attached to the curb prior to installing the unit. Refer to the Roof Curb Installation Instructions for proper curb installation. Curbing must be installed in compliance with the National Roofing Contractors Association Manual. Lower unit carefully onto roof mounting curb. While rigging the unit, the center of gravity will cause the condenser end to be lower than the supply air end. Bring condenser end of unit into alignment with the curb. With condenser end of the unit resting on curb member and using curb as a fulcrum, lower opposite end of the unit until entire unit is seated on the curb. When a rectangular cantilever curb is used, take care to center the unit. Check for proper alignment and orientation of supply and return openings with duct.

Roof Curb Installation

The roof curb is field-assembled and must be installed level (within 1/16” per foot side to side). A sub-base must be constructed by the contractor in applications involving pitched roofs. Gaskets are furnished and must be installed between the unit and curb. For proper installation, follow NRCA guidelines. In applications requiring post and rail installation, an I-beam securely mounted on multiple posts should support the unit on each side. In addition, the insulation on the underside of the unit should be protected from the elements. Applications in geographic areas subjected to seismic or hurricane conditions must meet code requirements for fastening the unit to the curb and the curb to the building structure. For further and more detailed information please refer to our Daikin Light Commercial Packaged unit IOD.

Weights

Model	Shipping Weight (lbs)	Operating Weight (lbs)	Corner Weights (lbs)				Length X (in)	Width Y (in)
			A	B	C	D		
DBC0363D000001S	568	528	112	164	127	124	35 ⁷ / ₁₀	26 ³ / ₄
DBC0483D000001S	598	558	115	186	127	130	34	27 ¹ / ₂
DBC0603D000001S	609	566	81	225	94	166	33 ⁹ / ₁₀	33 ³ / ₄

Accessories

Field Accessory part number	Description	Fits Model Sizes	Field-Installed	Factory-Installed	Operating Weight (lbs)
Electric Heat Kits					
EHXD-1S05	Electric Heater, Direct-Drive, 208-230V, 1PH, 5kW	3-5 ton	√	√	
EHXD-1S10	Electric Heater, Direct-Drive, 208-230V, 1PH, 10kW	3-5 ton	√	√	
EHXD-1S16	Electric Heater, Direct-Drive, 208-230V, 1PH, 15kW	3 ton	√	√	
EHXD-1S15	Electric Heater, Direct-Drive, 208-230V, 1PH, 15kW	4-5 ton	√	√	
EHXD-1S22	Electric Heater, Direct-Drive, 208-230V, 1PH, 20kW	4-5 ton	√	√	
EHXD-3S05	Electric Heater, Direct-Drive, 208-230V, 3PH, 5kW	3-5 ton	√	√	
EHXD-3S10	Electric Heater, Direct-Drive, 208-230V, 3PH, 10kW	3-5 ton	√	√	
EHXD-3S16	Electric Heater, Direct-Drive, 208-230V, 3PH, 15kW	3 ton	√	√	
EHXD-3S15	Electric Heater, Direct-Drive, 208-230V, 3PH, 15kW	4-5 ton	√	√	
EHXD-3S22	Electric Heater, Direct-Drive, 208-230V, 3PH, 20kW	4-5 ton	√	√	
Duct Smoke Detectors					
	Duct Smoke Detectors - Return	3-5 ton		√	11
	Duct Smoke Detectors - Supply	3-5 ton		√	11
	Duct Smoke Detectors - Supply and Return	3-5 ton		√	11
Non-Fused Disconnect Switch					
	60 Amp Disconnect	3-5 ton		√	5
	100 Amp Disconnect	3-5 ton		√	5
	150 Amp Disconnect	3-5 ton		√	5
Convenience Outlets					
	Convenience Outlets - Powered, 208/230 V	3-5 ton		√	42
	Convenience Outlets - Non-Powered	3-5 ton		√	2
Hinged Access Panels					
	Hinged Access Panels, 39" cabinet (Gas only)	3-5 Ton		√	
Economizer					
0270L01163	Horizontal Economizer Ultra Low-Leak (Title 24) JADE® Dry-Bulb, 39" cabinet	3-5 ton	√		88
0270L01759	Horizontal Economizer Ultra Low-Leak (Title 24) JADE Enthalpy Sensor, 39" cabinet	3-5 ton	√		88
0270L01753	Vertical Economizer Standard Low-Leak JADE Ethalpy Sensor	3-5 ton	√	√	65
0270L01755	Vertical Economizer Ultra Low-Leak (Title 24) JADE Ethalpy Sensor	3-5 ton	√	√	65
0270L01156	Vertical Economizer Standard Low-Leak JADE Dry-Bulb	3-5 ton	√	√	65
0270L01158	Vertical Economizer Ultra Low-Leak (Title 24) JADE Dry-Bulb	3-5 ton	√	√	65
Curbs and Restraint Clips					
0221L00014	Roof Curb 14" Tall, Knocked Down	3-5 ton	√		80
0221L00015	Roof Curb 24" Tall, Knocked Down	3-5 ton	√		109
0270L01261	Hold Down Bracket Kit	3-5 ton	√		8
0270L01250	Hold Down Bracket Kit for Daikin Roof curb	3-5 ton	√		8
0221L00019	Roof Curb 14" Tall Seismic with Hold Down Brackets, Knocked Down	3-5 ton	√		102
0221L00020	Roof Curb 14" Tall Wind-Rated Hurricane with Hold Down Brackets, Welded	3-5 ton	√		140
Concentrics					
0270L01602	Concentric Diffuser 24 x 48 with 16" Dia. collars	3-5 ton	√		32
0270L01603	Concentric Diffuser 24 x 48 with 18" Dia. collars	3-5 ton	√		35
0270L01335	Concentric Duct Adaptor Kit for 16" Dia. Duct	3-5 ton	√		28
0270L01338	Concentric Duct Adaptor Kit for 18" Dia. Duct	3-5 ton	√		28

Accessories availability may vary.

Accessories

Field Accessory part number	Description	Fits Model Sizes	Field-Installed	Factory-Installed	Operating Weight (lbs)
Dampers					
O270L01165	2 Position Motorized Damper	3-5 ton	√		40
O270L01166	Manual Outdoor Air Damper	3-5 ton	√		24
Hail Guard Kits					
HAILGD036HE	Condenser Coil Hail Guards, 39" cabinet	3-5 ton	√	√	
Crankcase Heater Kits					
HECH36230	Crankcase heater Kit 208/230 V	3 ton	√		1
HECH4860230	Crankcase heater Kit 208/230 V	4-5 ton	√		1
High-Efficiency Filters					
O160L00271	High-Efficiency MERV 8 Air Filter Kit- 20x25x2 (qty 2)	3-5 ton	√		4
O160L00202	High-Efficiency MERV 13 Air Filter Kit- 20x25x2 (qty 2)	3-5 ton	√		4
Misc Accessories					
TTBCKHE01	Through the Base Gas/Electrical	3-5 ton	√	√	1
3PMKP1	Phase Monitor Kit	3-5 ton	√	√	2
O270L01232	Burglar bars Inserts	3-5 ton	√		18
Power Exhaust					
O270L01167	Power Exhaust Prop Downflow Economizer, 230 V	3-5 ton	√		57
O270L01170	Power Exhaust Prop Horizontal Economizer, 230 V	3-5 ton	√		47
Controls, Thermostats and Sensors					
DT4272C	Comm Touch Digital Stat w/ WiFi 4h/2c	3-25 ton	√		1
DT4273C	Comm Touch Digital Stat w/ WiFi & Humidity Control 4h/2cc	3-25 ton	√		1
PSPAC-WS	Remote indoor sensor	3-25 ton	√		1
250803400	AppStat™ RTU 2H/2C Econ	3-25 ton	√		1
250803600	AppStat™ HPU 3H/2C Econ (Heat Pump)	3-25 ton	√		1
D4271C	4h/2c Commercial 7day Programmable Wi-Fi Capable thermostat	3-25 ton	√		1
D4272C	4h/2c Commercial 7day Programmable Wi-Fi Capable Hum/dehum thermostat	3-25 ton	√		1
C7232A1024	CO ₂ Sensor (Wall Mtd)	3-25 ton	√		1
C7232B1022	CO ₂ Sensor (Duct Mtd)	3-25 ton	√		1
D2270C	Mini Wi-Fi Thermostat	3-25 ton	√		1
TSTATD2152-2	Value Series 2h/1c 5+2 prgm (Heat Pump)	3-25 ton	√		1
TSTATD2100-2	Value Series 2h/1c No prgm (Heat Pump)	3-25 ton	√		1
TSTATD1100-2	Value Series 1h/1c No prgm	3-25 ton	√		1
TSTATD1152-2	Value Series 1h/1c 5+2 prgm	3-25 ton	√		1
PSPAC-AW	Add-A-Wire	3-25 ton	√		1
PSPAC-2W	2-Wire Kit	3-25 ton	√		1
PSPAC-OS	Wired Indoor / Outdoor Remote Sensor	3-25 ton	√		1
PSPAC-DS	Wired Duct Sensor	3-25 ton	√		1
PSPAC-WFMS	Wireless Wi-Fi Mini Sensor	3-25 ton	√		1
PSPAC-LR	Lock Ring for Premium Commercial Thermostats	3-25 ton	√		1
PSPAC-PWF	Wi-Fi Module	3-25 ton	√		1
PSPAC-WP	Wall Plate- Premium & Value Series	3-25 ton	√		1
PSPAC-WPT	Wall Plate Color Touch Screen	3-25 ton	√		1
PSPAC-WPM-S	Wall Plate Premium Mini- Small	3-25 ton	√		1
PSPAC-WPM-M	Wall Plate Premium Mini- Medium	3-25 ton	√		1
PSPAC-WPM-L	Wall Plate Premium Mini- Large	3-25 ton	√		1
C7400S1000	Differential Enthalpy Sensor	3-25 ton	√		1
D4120	Smoke Detector- Duct Mounted	3-25 ton	√		1
D4120W	Smoke Detector- Watertight	3-25 ton	√		1

Note: Where multiple variations are available, the heaviest combination is listed. Accessories availability may vary.

Factory Installed Options

- » **Non-Powered Convenience Outlet:** A 120V, 15A, GFCI outlet can be installed in the unit making it easier for technicians to service other units once an electrician runs power to the outlet. Outlet shall be factory-installed and internally mounted with easily accessible 120-v female receptacle. Transformer not included for this option. Outlet shall include a field-installed "While-in-Use" cover.
- » **Powered Convenience Outlet:** A 115V, 15A, GFCI outlet can be powered with a step-transformer built into the unit. When a factory-installed powered convenience outlet is installed in the equipment, the unit MCA (Min. Circuit Ampacity) will increase by 9.6A for 208V units; increase by 8.7A for 230V; increase by 4.35A for 460V units; and by 3.5A for 575V units. The MOP (Max. Overcurrent Protection) device must be sized accordingly. Outlet shall be powered from main line power to the rooftop unit. Outlet shall include a field installed "While-in-Use" cover.
- » **Return Air and/or Supply Air Smoke Detectors:** Return air and/or supply air smoke detectors can be installed in the unit. To safely identify the presence of smoke inside the air conditioning system and shutdown the blower to prevent the smoke to disperse into different zones.
- » **Disconnect Switch (non-fused):** A disconnect switch can be installed in the unit with factory wiring complete from the switch to the unit. Please note that for air conditioner and heat pump units, the appropriate electric heat kit must be ordered along with the disconnect switch (non-fused) to be factory-installed. For models with a powered convenience outlet option and a disconnect switch (non-fused) option, the power to the powered convenience outlet will be shut off when the disconnect switch (non-fused) is in the off position. National Electric Code (NEC) and UL approved non-fused switch shall provide unit power shutoff. The switch shall be accessible from outside of the unit and provide local shutdown and lockout capability.
- » **Hinged Access Panels:** Allows access to unit's major components. Combined with latches for easy access to control box, compressor, filters and blower motor.
- » **Through-the-base electrical connection:** Allows an easy and fast field installation through the unit base pan.
- » **Electromechanical Controls:** Basic controls that include terminal block for unit connectivity to T-Stat.

Field Installed Options

- » **Manual Fresh Air Damper:** Manual damper package shall consist of damper, air inlet screen, and rain hood which can be preset to admit up to 25% outdoor air for year round ventilation.
- » **Motorized Fresh Air Damper:** A two-position damper with rain hood and screen provides up to 50% outside air when the indoor fan starts and closes when the indoor fan shuts down. Consist of actuator, damper, air inlet screen, and rain hood. Damper shall close upon indoor (evaporator) fan shutoff and/or loss of power. The damper actuator shall plug into the rooftop unit's wiring harness plug. No hard wiring shall be required.
- » **Power Exhaust:** Power exhaust shall be used in conjunction with an integrated economizer. This accessory exhausts return air and may be used in either downflow or horizontal (duct-mounted) applications. Horizontal power exhaust shall be mounted in return ductwork. Power exhaust shall be controlled by economizer controller operation. Exhaust fans shall be energized when dampers open past the 0-100% adjustable setpoint on the economizer control.
- » **Horizontal Economizer:** Fully modulating between 0 and 100%, contain seals that meet ASHRAE 90.1 requirements. Includes motor and dampers, minimum position settings, preset linkage, wiring harness with plug, mixed air temperature sensor, and enthalpy control. An optional duct-mounted barometric relief damper is available. An optional return enthalpy sensor is available to provide comparative or differential enthalpy control. Damper blades shall be galvanized steel with composite gears. Plastic or composite blades on intake or return shall not be acceptable. Standard leak rate shall be equipped with dampers not to exceed 2% leakage at 1 in. wg pressure differential. Ultra Low Leak design meets California Title 24 section 140.4 and ASHRAE 90.1 requirements for 4 cfm per sq.ft. on the outside air dampers and 10 cfm per sq. ft. on the return dampers. Shall be designed to close damper(s) during loss-of-power situations with spring return built into motor. Economizer controller shall accept a 2-10 Vdc CO₂ sensor input for IAQ/DCV control. In this mode, dampers shall modulate the outdoor air damper to provide ventilation based on the sensor input.
- » Economizer controller shall be Honeywell® JADE® W7220 that provides:
 - 2-line LCD interface screen for setup, configuration and troubleshooting.
 - On-board Fault Detection and Diagnostics (FDD) that senses and alerts when the economizer is not operating properly, per California Title 24.
 - Sensor failure loss of communication identification
 - Automatic sensor detection
 - Capabilities for use with multiple-speed indoor fan systems
 - Utilize digital sensors: Dry bulb and Enthalpy
 - Economizer controller shall provide indications when in free cooling mode, in the DCV mode, or the exhaust fan contact is closed.

- » **Roof curbs:** Full perimeter roof curb with exhaust capability providing separate air streams for energy recovery from the exhaust air without supply air contamination. Two different heights 14" and 24", allows proper installation and structure stability. Formed galvanized steel with wood nailer strip and shall be capable of supporting entire unit weight.
- » **Concentric duct kits:** Designed to provide a single-point air distribution system with the added benefit of having directional air control.
- » **Restraint mounting clips:** Allows for installation reinforcement for Hurricane and/or seismic events.
- » **CO₂ sensor:** Sensor designed to alarm the system when the CO₂ levels are outside safe parameters.
- » **Burglar Bar Sleeves:** Designed to prevent the access thru the return or supply ducting inside the unit.
- » **Downflow square to round adapter 18":** Installed into a recessed portion of the roof curb, the concentric duct adaptor changes the orientation of the ductwork from square to round for applications utilizing that type of ducting system.
- » **Side discharge concentric diffuser system:** The Concentric diffuser system is an all in one supply and return duct free arrangement for RTU systems. This system comes with two separate duct connections, one for a supply and another for a return.
- » **Remote indoor sensor:** Remote sensor to monitor the temperature on zones away from the main thermostat.
- » **Drain pan overflow switch:** Allows the controls to detect and send an alarm when there is an overflow on the drain pan.
- » **Freeze stat:** Temperature sensing device that monitors the heat exchange to prevent the coil from freezing.

Factory and Field Installed Options

- » **Downflow Economizer:** Fully modulating between 0 and 100%, contain seals that meet ASHRAE 90.1 requirements. Includes motor and dampers, minimum position settings, a preset linkage, a wiring harness with plug, a mixed air temperature sensor, enthalpy control, and a barometric relief damper. An optional return enthalpy sensor is available to provide comparative or differential enthalpy control. Damper blades shall be galvanized steel with composite gears. Plastic or composite blades on intake or return shall not be acceptable. Standard leak rate shall be equipped with dampers not to exceed 2% leakage at 1 in. wg pressure differential. Ultra Low Leak design meets California Title 24 section 140.4 and ASHRAE 90.1 requirements for 4 cfm per sq.ft. on the outside air dampers and 10 cfm per sq. ft. on the return dampers. Shall be designed to close damper(s) during loss-of-power situations with spring return built into motor. Economizer controller shall accept a 2-10 Vdc CO₂ sensor input for IAQ/DCV control. In this mode, dampers shall modulate the outdoor air damper to provide ventilation based on the sensor input. Economizer controller shall be Honeywell® W7220 that provides:
 - » Economizer controller shall be *Honeywell* W7220 that provides:
 - 2-line LCD interface screen for setup, configuration and troubleshooting.
 - On-board Fault Detection and Diagnostics (FDD) that senses and alerts when the economizer is not operating properly, per California Title 24.
 - Sensor failure loss of communication identification
 - Automatic sensor detection
 - Capabilities for use with multiple-speed indoor fan systems
 - Utilize digital sensors: Dry bulb and Enthalpy
 - Economizer controller shall provide indications when in free cooling mode, in the DCV mode, or the exhaust fan contact is closed.
 - » **Low Ambient Control:** Allows cooling operation down to 35°F outdoor ambient temperature for 3 - 6 ton units.
 - » **Phase Monitor:** Phase monitor (3-Phase only) shall provide protection for motors and compressors against problems caused by phase loss, phase reversal and phase unbalance. Phase monitor is equipped with an LED that provides an ON or FAULT indicator.
 - » **Condenser Hail Guards:** Louvered metal guards help protect the condenser coil from hail and debris; available as a field-installed options on 3 – 12½ ton units.

