



# Product Data

## Gemini™ Select 38APS025-065, 38APD025-130 Commercial Air-Cooled Condensing Units with Puron® Refrigerant (R-410A) 50/60 Hz

25 to 130 Nominal Tons (88 to 457 Nominal kW)



## Gemini™ Select

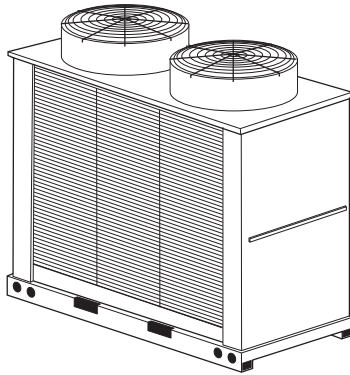

025 UNIT WITH  
LOW SOUND OPTION

040-060 UNIT

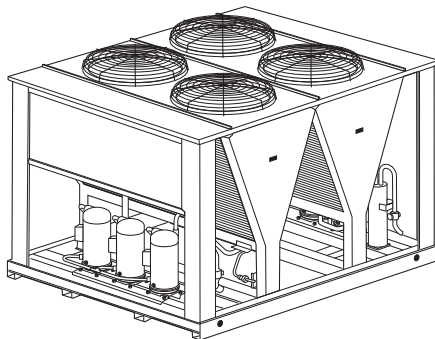
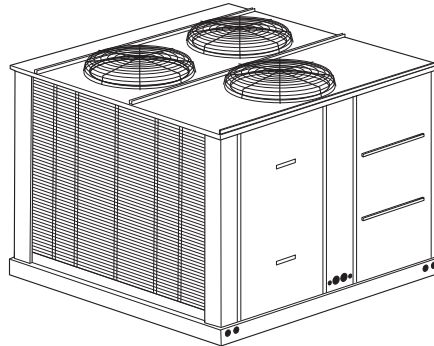

070 UNIT



These dependable split systems match Carrier's 40RU or 39 Series indoor-air handlers with the versatile outdoor 38AP condensing units for a wide selection of commercial cooling solutions.

- Split condensing units compatible with ASHRAE 90.1
- Chlorine-free, non-ozone depleting Puron refrigerant (R-410A)
- Condenser coils feature the Novation® heat exchanger with microchannel coil technology
- 38APS single-circuit unit has up to 3 rotary scroll compressors
- 38APD unit has up to 6 rotary scroll compressors with 2 independent circuits
- Standard scroll compressor units operate as low as 33% (single circuit) or 13% (dual circuit) of nominal capacity
- Optional digital scroll compressors allow incremental unloading down to 16% (single circuit) or 6% (dual circuit) of nominal capacity for VAV applications. The digital scroll is always on the lead circuit (one per unit).
- Protection against high discharge and low suction refrigerant pressure, and low oil pressure

## Features/Benefits

**The 38AP condensing unit offers the utmost in system configuration and control adaptability. Its premium-quality standard components ensure durable, efficient, and reliable operation.**

The 38AP units offer high unit EERs (Energy Efficiency Ratios) up to 11.5 and IPLVs (integrated part load values) up to 16.2.

# Features/Benefits (cont)



These units provide greater efficiency than similar units in the marketplace, which translates into year-round operating savings.

The latest safety standards for 38AP units are tested per UL (Underwriters Laboratories) and CSA (Canadian Standards Association) standards and certified by ETL.

## Versatility

The 38AP Series condensing units feature up to 6 compressors and 2 refrigerant circuits, and can be matched with a wide variety of air-handling units. Single circuit condensing units can operate with a single air handler. Dual circuit condensing units can operate with a single air handler or two separate air handlers. Standard units have multiple scroll compressors. A digital scroll option is available. This option of digital control closely matches building loads and allows fine incremental adjustments to the variance in load.

## Durable construction

All 38AP units have weatherized cabinets constructed of heavy-duty galvanized steel prepainted with corrosion-resistant baked enamel. Inside and outside surfaces are protected to ensure long life and good appearance. The durable, galvanized steel, prepainted components exceed the requirements of the 500-hour salt spray test per ASTM (American Society for Testing and Materials) B117.

All 38AP units have Novation® heat exchangers with microchannel coil technology. The microchannel heat exchanger (MCHX) coils provide long-term reliability, high performance heat

transfer, and significant savings in refrigerant charge. E-coated MCHX is offered as an option for harsh industrial or coastal conditions. As an individual component, the e-coated MCHX coil can withstand an 8,000-hour salt spray test in accordance with ASTM B-117 Standard.

## Reliability

The 38AP condensing units feature highly reliable, hermetic scroll compressors. Each 38AP unit is capable of unloading in staging sequence of scroll compressors. Compressors are mounted on rails with vibration isolators to provide quiet operation and reduced component stress.

The 38AP units have single or dual independent circuits; they provide inherent backup capability. Each circuit is also protected by the following safety features:

- Short-cycle protection
- Low superheat protection
- Loss of refrigerant charge protection
- Reverse rotation protection
- Suction and discharge pressure transducers
- High refrigerant pressure switch (discharge)
- Circuit breakers or fuses for short circuit protection of compressors and outdoor fans
- Suction line accumulator for each refrigerant circuit

## Easier installation and service

The 38AP units are equipped with hinged control-box access doors, control interface terminal boards, liquid

line shutoff valves, and suction line service valves.

## ComfortLink controls

The *ComfortLink* controls communicate in plain English, making it as easy as possible to monitor and control each Gemini™ Select condensing unit while accurately maintaining air temperatures. The large scrolling marquee display acts as a window into the unit's operation, providing easy-to-read information about chiller performance and over 15 diagnostic functions.

Carrier's 38 Series condensing units' *ComfortLink* controls provide features such as supply air temperature reset, demand limit, 4 to 20 mA input compressor wear minimization and protection, temperature and pressure displays and diagnostic functions. These controls result in higher chiller reliability, simplified training and more productive service calls with correspondingly lower operational and maintenance costs.

Carrier's exclusive accessory handheld Navigator™ display provides convenience and powerful information in the palm of your hand. The Navigator display helps technicians to quickly diagnose problems and even prevent them from occurring.

All Gemini Select units are ready to be used with the Carrier Comfort Network® (CCN) system. A BACnet\* communication option is also available for the i-Vu® Open control system or a BACnet building automation system.

## Seismic certification

A seismic kit is available which will result in a unit SDS (seismic design acceleration parameter) level of 2.5 for 38AP025-065 units and 2.1 for 38AP070-130 units.

# Table of contents

	Page
Features/Benefits . . . . .	1-3
Model Number Nomenclature . . . . .	4
Capacity Ratings . . . . .	5
Physical Data . . . . .	6-9
Options and Accessories . . . . .	10,11
Dimensions . . . . .	12-16
Selection Procedure . . . . .	17
Performance Data . . . . .	18-71
Typical Piping and Wiring . . . . .	72-74
Electrical Data . . . . .	75-78
Controls . . . . .	79-81
Typical Control Wiring Schematics . . . . .	82-90
Application Data . . . . .	91-97
Guide Specifications . . . . .	98-101

\*Sponsored by ASHRAE (American Society of Heating, Refrigerating and Air-Conditioning Engineers).

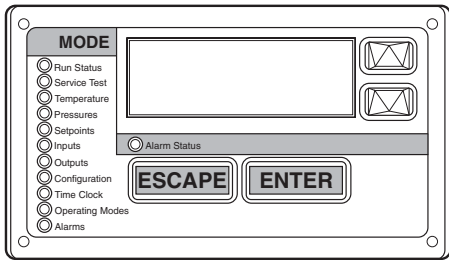

**SCROLLING MARQUEE DISPLAY**

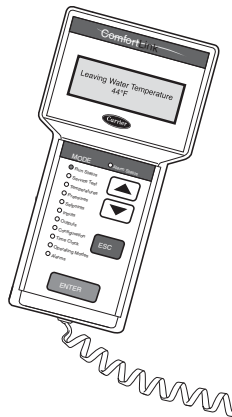

**NAVIGATOR™ DISPLAY**

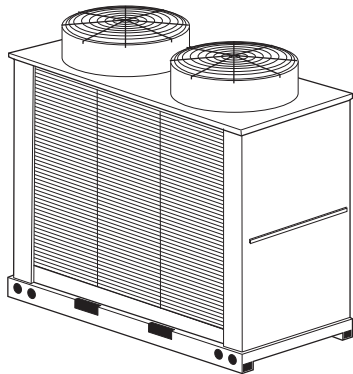

**LOW SOUND OPTION**

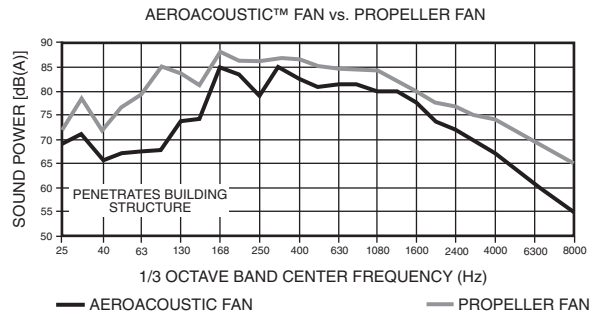

**AEROACOUSTIC FAN VS PROPELLER FAN**

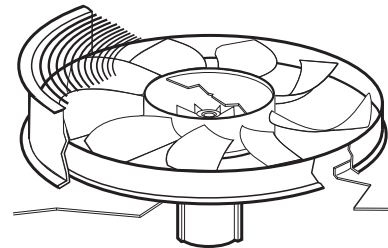

**LOW-NOISE AEROACOUSTIC FAN**

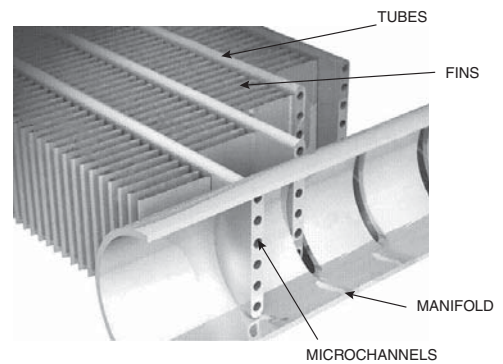

**NOVATION® HEAT EXCHANGER TECHNOLOGY WITH MICROCHANNEL CONDENSER COILS**

# Model number nomenclature



38AP D 025 6 4 A 1 0 0 2 0

38AP – Split System Condensing Unit

**Refrigeration Circuit Options\***

- D – Dual Refrigeration Circuit
- S – Single Refrigeration Circuit

**Unit Size**

- |     |     |     |
|-----|-----|-----|
| 025 | 060 | 100 |
| 027 | 065 | 115 |
| 030 | 070 | 130 |
| 040 | 080 |     |
| 050 | 090 |     |

**Power Supply**

- 1 – 575-3-60
- 2 – 380-3-60
- 5 – 280/230-3-60
- 6 – 460-3-60
- 9 – 380/415-3-50

**Condenser Coil/Low Sound Options**

- 4 – MCHX, No Sound Treatment
- 5 – E-coat, MCHX, No Sound Treatment
- C – MCHX, Low Sound Fan(s)
- D – E-coat MCHX, Low Sound Fan(s)
- H – MCHX, Low Sound Fan(s), Compressor Blankets
- J – E-coat MCHX, Low Sound Fan(s), Compressor Blankets

**Revision Level**

- A
- B (Unit Sizes 065,115,130 Only)

**Packaging/Security Options**

- 0 – Std Packaging
- 4 – Security Grilles/Hail Guards
- 8 – Std Packaging, Bottom Skid
- D – Bottom Skid, Security Grilles/Hail Guards
- J – Bottom Skid, Top Crate, Bag
- N – Bottom Skid, Top Crate, Bag, Security Grilles/Hail Guards

**Controls/Communications Options**

- 2 – Standard, Scrolling Marquee
- 3 – EMM, Scrolling Marquee
- 8 – Scrolling Marquee, BACnet Communication
- 9 – Scrolling Marquee, EMM, BACnet Communication

**Electrical Options**

- 0 – Single Point Power, XL, Terminal Block
- 1 – Single Point Power, XL, Non-Fused Disconnect
- 2 – Dual Point Power, XL, Terminal Block\*\*

**Ambient/Capacity Control/High SCCR Options†**

- 0 – Std Ambient, Std Compressor
- 2 – Std Ambient, Digital Compressor
- 3 – Std Ambient, Std Compressor, High SCCR
- 5 – Std Ambient, Digital Compressor, High SCCR
- 6 – Low Ambient, Std Compressor
- 8 – Low Ambient, Digital Compressor
- 9 – Low Ambient, Std Compressor, High SCCR
- C – Low Ambient, Digital Compressor, High SCCR

**Line Length Options**

- 1 – Standard Line Length
- 2 – Long Line Length Check Valves

**LEGEND**

- EMM – Energy Management Module
- MCHX – Microchannel Heat Exchanger
- SCCR – Short Circuit Current Rating
- XL – Across-the-Line Start

\*38APS units available in sizes 025-050 and 065 only.

†Digital compressor not available on size 065.

\*\*Only available on sizes 115 and 130.

**Quality Assurance**

Certified to ISO 9001

# Capacity ratings



## 38AP UNIT CAPACITY RATINGS

UNIT SIZE	CAPACITY NOMINAL TONS (60 Hz)	CAPACITY NOMINAL kW (60 Hz)	CAPACITY NOMINAL TONS (50 Hz)	CAPACITY NOMINAL kW (50 Hz)	EER (60 Hz)	EER (50 Hz)	IPLV (60 Hz)	IPLV (50 Hz)
38APS025	24.0	84.3	20.0	70.3	11.0	11.6	14.4	16.4
38APD025	24.0	84.3	20.0	70.3	11.0	11.6	13.1	14.9
38APS027	26.6	93.4	22.2	78.1	10.9	11.7	14.7	16.6
38APD027	26.6	93.4	22.2	78.1	10.9	11.7	14.0	15.4
38APS030	31.1	109.2	26.0	91.4	10.8	11.5	14.3	15.9
38APD030	31.1	109.2	26.0	91.4	10.8	11.5	12.8	14.2
38APS040	39.8	139.8	32.8	115.3	11.5	12.4	16.2	18.4
38APD040	39.2	137.7	32.6	114.6	11.5	12.1	15.3	17.4
38APS050	48.1	168.9	39.5	138.9	10.8	11.8	15.0	16.7
38APD050	50.0	175.6	41.6	146.3	11.1	11.4	14.9	16.7
38APD060	58.3	204.7	48.0	168.8	11.0	11.5	14.5	16.4
38APS065	59.6	209.6	49.4	173.7	11.1	11.5	15.1	17.0
38APD070	67.3	236.4	58.5	205.7	11.0	11.3	15.7	17.7
38APD080	78.0	273.9	64.5	226.8	11.1	11.5	15.6	17.5
38APD090	87.4	306.9	71.9	252.8	11.3	11.8	15.3	17.4
38APD100	96.0	337.2	79.8	280.6	11.1	11.6	15.0	16.9
38APD115	110.4	388.3	90.8	319.3	11.1	11.6	15.2	17.1
38APD130	125.1	442.3	103.7	364.6	11.1	11.5	15.2	17.1

### LEGEND

**EER** — Energy Efficiency Ratio  
**IPLV** — Integrated Part Load Value

### NOTES:

1. Unit performance is rated in accordance with AHRI (Air-Conditioning, Heating, and Refrigeration Institute) Standard 365.
2. Ratings are based on 45 F (7.2 C) saturated suction temperature and 95 F (35 C) outside-air temperature, standard fans, and include suction line losses.

# Physical data



## 38AP025-050 UNITS — ENGLISH

38AP UNIT SIZE	025		027		030		040		050	
<b>NOMINAL CAPACITY, 50/60 Hz (tons)</b>	21/25		23/27		25/30		33/40		42/50	
<b>CIRCUIT</b>	Dual	Single	Dual	Single	Dual	Single	Dual	Single	Dual	Single
<b>OPERATING WEIGHTS (lb)</b>										
Standard	1095	1077	1258	1240	1264	1246	2094	1968	2120	1977
With Low Sound Option	1131	1113	1294	1276	1300	1282	2148	2022	2174	2031
<b>REFRIGERANT CHARGE (lb)</b>										
Total*	24	24	26	26	28	29	38	39	48	48
Circuit A/Circuit B	12/12	24/—	13/13	26/—	14/14	29/—	21/17	39/—	22/26	48/—
<b>NITROGEN SHIPPING CHARGE</b>	15 psig									
<b>COMPRESSOR hp (Qty) (CKT A/CKT B)</b>	11 (1)/ 11 (1)	11 (2)	13 (1)/ 13 (1)	13 (2)	15 (1)/ 15 (1)	15 (2)	10 (2)/ 8.5 (2)	13 (3)	11 (2)/ 13 (2)	15 (3)
<b>CAPACITY STEPS</b>										
Standard	2	2	2	2	2	2	4	3	4	3
Digital Option	22	22	22	22	22	22	36	27	36	27
<b>CRANKCASE HEATER (W) (each compressor)</b>	90 (60/50 Hz)									
<b>CONDENSER FANS</b>	Propeller Type, Axial, Vertical Discharge									
Standard	1140 (60 Hz), 950 (50 Hz)									
Quantity	2	2	2	2	2	2	3	3	3	3
RPM	30									
Diameter (in.)	30									
Total Watts (60 Hz)	3300	3300	3300	3300	3300	3300	4200	4200	4200	4200
Total Watts (50 Hz)	1997	1997	1997	1997	1997	1997	2541	2541	2541	2541
Low Noise	Plastic Type, Axial, Vertical Discharge									
Quantity	2	2	2	2	2	2	3	3	3	3
RPM	850 (60 Hz), 700 (50 Hz)									
Diameter (in.)	30									
Total Watts (60 Hz)	2750	2750	2750	2750	2750	2750	3500	3500	3500	3500
Total Watts (50 Hz)	1664	1664	1664	1664	1664	1664	2118	2118	2118	2118
<b>CONDENSER COIL</b>	MCHX Type									
No. Coils per Circuit	1	1	1	1	1	1	1	2	1	2
sq ft	27.1	27.1	33.9	33.9	33.9	33.9	67.8	67.8	67.8	67.8
<b>TEMPERATURE RELIEF</b>	Fusible Plug on Liquid Lines of Each Circuit - 210 F									
<b>CONNECTIONS (in.) ODF (CKT A/CKT B)</b>	Fusible Plug on Liquid Lines of Each Circuit - 210 F									
Suction Line	13/8 / 13/8	15/8	13/8 / 13/8	15/8	13/8 / 13/8	15/8	15/8 / 15/8	21/8	15/8 / 15/8	21/8
Liquid Line	5/8 / 5/8	5/8	5/8 / 5/8	5/8	5/8 / 5/8	7/8	5/8 / 5/8	7/8	5/8 / 5/8	7/8
<b>MAXIMUM HEIGHT FOR 3° F SUBCOOLING (ft)†</b>	75	75	75	75	75	75	75	75	75	75
<b>CAPACITY PER CIRCUIT (%) (CKT A/CKT B)</b>	50/50	100	50/50	100	50/50	100	54/46	100	48/52	100
<b>MINIMUM UNIT CAPACITY (%)</b>										
Standard Compressor	50	50	50	50	50	50	27	33	23	33
Digital Compressor	17	17	17	17	17	17	13	16	11	16

**LEGEND**

- MCHX** — Microchannel Heat Exchanger
- ODF** — Outside Diameter, Female

\*Typical operating charge with 25 ft of interconnecting piping. Operating charge is approximate for maximum system capacity. Unit is factory supplied with nitrogen holding charge. Refrigerant charge for dual circuit units is the total for both circuits.

†Maximum vertical separation between evaporator coil and condensing unit.

NOTE: Refer to Loading Sequences tables in Application Data section on page 92 or contact Application Engineering for detailed capacity step data.





### 38AP060-130 UNITS — ENGLISH

38AP UNIT SIZE	060	065	070	080	090	100	115	130
<b>NOMINAL CAPACITY, 50/60 Hz (tons)</b>	50/60	54/65	58/70	67/80	75/90	83/100	96/115	108/130
<b>CIRCUIT</b>	Dual	Single	Dual	Dual	Dual	Dual	Dual	Dual
<b>OPERATING WEIGHTS (lb)</b>								
Standard	2227	2333	2450	2610	2835	2844	3211	3353
With Low Sound Option	2299	2387	2522	2700	2943	2952	3319	3461
<b>REFRIGERANT CHARGE (lb)</b>								
Total*	56	55	62	75	85	92	101	117
Circuit A/Circuit B	27/29	—/55	29/33	29/46	39/46	46/46	46/55	46/71
<b>NITROGEN SHIPPING CHARGE</b>	15 psig							
<b>COMPRESSOR hp (Qty) (CKT A/CKT B)</b>	13 (2)/15 (2)	20 (3)	15 (2)/11 (3)	15 (2)/15 (3)	13 (3)/15 (3)	15 (3)/15 (3)	15 (3)/20 (3)	15 (3)/25 (3)
<b>CAPACITY STEPS</b>								
Standard	4	3	5	5	6	6	6	6
Digital Option	36	—	45	45	54	54	54	54
<b>CRANKCASE HEATER (W) (each compressor)</b>	90 (60/50 Hz)						90 CKT A, 120 CKT B (60/50 Hz)	
<b>CONDENSER FANS</b>	Propeller Type, Axial, Vertical Discharge							
Standard	Quantity							
Quantity	4	4	4	5	6	6	7	8
RPM	1140 (60 Hz), 950 (50 Hz)							
Diameter (in.)	30							
Total Watts (60 Hz)	6200	6000	6000	7500	9000	9000	10,500	12,000
Total Watts (50 Hz)	3751	3630	3630	4538	5445	5445	6353	7260
Low Noise	Plastic Type, Axial, Vertical Discharge							
Quantity	4	4	4	5	6	6	7	8
RPM	850 (60 Hz), 700 (50 Hz)							
Diameter (in.)	30							
Total Watts (60 Hz)	5200	5000	5000	6250	7500	7500	8750	10,000
Total Watts (50 Hz)	3146	3025	3025	3781	4538	4538	5294	6050
<b>CONDENSER COIL</b>	MCHX Type							
No. Coils per Circuit	1	3	2	2 to 3	3	3	3 to 4	3 to 5
sq ft	67.8	99.6	99.6	124.5	149.4	149.4	174.3	199.2
<b>TEMPERATURE RELIEF</b>	Fusible Plug on Liquid Lines of Each Circuit - 210 F							
<b>CONNECTIONS (in.) ODF (CKT A/CKT B)</b>	Suction Line							
Suction Line	1 <sup>5</sup> / <sub>8</sub> / 1 <sup>5</sup> / <sub>8</sub>	2 <sup>5</sup> / <sub>8</sub>	1 <sup>5</sup> / <sub>8</sub> / 2 <sup>1</sup> / <sub>8</sub>	1 <sup>5</sup> / <sub>8</sub> / 2 <sup>1</sup> / <sub>8</sub>	2 <sup>1</sup> / <sub>8</sub> / 2 <sup>1</sup> / <sub>8</sub>	2 <sup>1</sup> / <sub>8</sub> / 2 <sup>1</sup> / <sub>8</sub>	2 <sup>1</sup> / <sub>8</sub> / 2 <sup>5</sup> / <sub>8</sub>	2 <sup>1</sup> / <sub>8</sub> / 2 <sup>5</sup> / <sub>8</sub>
Liquid Line	5 <sup>8</sup> / <sub>8</sub> / 5 <sup>8</sup> / <sub>8</sub>	7 <sup>8</sup> / <sub>8</sub>	7 <sup>8</sup> / <sub>8</sub> / 7 <sup>8</sup> / <sub>8</sub>	7 <sup>8</sup> / <sub>8</sub> / 7 <sup>8</sup> / <sub>8</sub>	7 <sup>8</sup> / <sub>8</sub> / 7 <sup>8</sup> / <sub>8</sub>	7 <sup>8</sup> / <sub>8</sub> / 7 <sup>8</sup> / <sub>8</sub>	7 <sup>8</sup> / <sub>8</sub> / 7 <sup>8</sup> / <sub>8</sub>	7 <sup>8</sup> / <sub>8</sub> / 1 <sup>1</sup> / <sub>8</sub>
<b>MAXIMUM HEIGHT FOR 3° F SUBCOOLING (ft)†</b>	75	75	75	75	75	75	75	75
<b>CAPACITY PER CIRCUIT (%) (CKT A/CKT B)</b>	46/54	100	47/53	40/60	46/54	50/50	44/56	38/62
<b>MINIMUM UNIT CAPACITY (%)</b>								
Standard Compressor	23	33	24	20	15	17	14	13
Digital Compressor	11	—	11	9	7	8	7	6

**LEGEND**

**MCHX** — Microchannel Heat Exchanger  
**ODF** — Outside Diameter, Female

\*Typical operating charge with 25 ft of interconnecting piping. Operating charge is approximate for maximum system capacity. Unit is factory supplied with nitrogen holding charge. Refrigerant charge for dual circuit units is the total for both circuits.

†Maximum vertical separation between evaporator coil and condensing unit.

NOTE: Refer to Loading Sequences tables in Application Data section on page 92 or contact Application Engineering for detailed capacity step data.

# Physical data (cont)



## 38AP025-050 UNITS — SI

38AP UNIT SIZES	025		027		030		040		050	
<b>NOMINAL CAPACITY 50/60 Hz (kW)</b>	73/88		79/95		88/105		117/141		146/176	
<b>CIRCUIT</b>	Dual	Single	Dual	Single	Dual	Single	Dual	Single	Dual	Single
<b>OPERATING WEIGHTS (kg)</b>										
Standard	497	489	571	562	573	565	950	893	961	897
With Low Sound Option	513	505	587	579	590	582	974	917	986	921
<b>REFRIGERANT CHARGE (kg)</b>										
Total*	12	11	12	12	14	13	18	18	22	22
Circuit A/Circuit B	6/6	11/—	6/6	12/—	7/7	13/—	10/8	18/—	10/12	22/—
<b>NITROGEN SHIPPING CHARGE</b>	1.03 bar									
<b>COMPRESSOR kW (Qty) (CKT A/CKT B)</b>	8.2 (1)/ 8.2 (1)	8.2 (2)	9.7 (1)/ 9.7 (1)	9.7 (2)	11.2 (1)/ 11.2 (1)	11.2 (2)	7.5 (2)/ 6.3 (2)	9.7 (3)	8.2 (2)/ 9.7 (2)	11.2 (3)
<b>CAPACITY STEPS</b>										
Standard	2	2	2	2	2	2	4	3	4	3
Digital Option	22	22	22	22	22	22	36	27	36	27
<b>CRANKCASE HEATER (W) (each compressor)</b>	90 (60/50 Hz)									
<b>CONDENSER FANS</b>										
Standard	Propeller Type, Axial, Vertical Discharge									
Quantity	2	2	2	2	2	2	3	3	3	3
r/s	19 (60 Hz), 16 (50 Hz)									
Diameter (mm)	762									
Total Watts (60 Hz)	3300	3300	3300	3300	3300	3300	4200	4200	4200	4200
Total Watts (50 Hz)	1997	1997	1997	1997	1997	1997	2541	2541	2541	2541
Low Noise	Plastic Type, Axial, Vertical Discharge									
Quantity	2	2	2	2	2	2	3	3	3	3
r/s	14 (60 Hz), 12 (50 Hz)									
Diameter (mm)	762									
Total Watts (60 Hz)	2750	2750	2750	2750	2750	2750	3500	3500	3500	3500
Total Watts (50 Hz)	1664	1664	1664	1664	1664	1664	2118	2118	2118	2118
<b>CONDENSER COIL</b>	MCHX Type									
No. Coils per Circuit	1	1	1	1	1	1	1	2	1	2
sq m	2.5	2.5	3.1	3.1	3.1	3.1	6.3	6.3	6.3	6.3
<b>TEMPERATURE RELIEF</b>	Fusible Plug on Liquid Lines of Each Circuit - 99 C									
<b>CONNECTIONS (in.) ODF (CKT A/CKT B)</b>										
Suction Line	1 <sup>3</sup> / <sub>8</sub> / 1 <sup>3</sup> / <sub>8</sub>	1 <sup>5</sup> / <sub>8</sub>	1 <sup>3</sup> / <sub>8</sub> / 1 <sup>3</sup> / <sub>8</sub>	1 <sup>5</sup> / <sub>8</sub>	1 <sup>3</sup> / <sub>8</sub> / 1 <sup>3</sup> / <sub>8</sub>	1 <sup>5</sup> / <sub>8</sub>	1 <sup>5</sup> / <sub>8</sub> / 1 <sup>5</sup> / <sub>8</sub>	2 <sup>1</sup> / <sub>8</sub>	1 <sup>5</sup> / <sub>8</sub> / 1 <sup>5</sup> / <sub>8</sub>	2 <sup>1</sup> / <sub>8</sub>
Liquid Line	5 <sup>8</sup> / <sub>8</sub> / 5 <sup>8</sup> / <sub>8</sub>	5 <sup>8</sup> / <sub>8</sub>	5 <sup>8</sup> / <sub>8</sub> / 5 <sup>8</sup> / <sub>8</sub>	5 <sup>8</sup> / <sub>8</sub>	5 <sup>8</sup> / <sub>8</sub> / 5 <sup>8</sup> / <sub>8</sub>	7 <sup>8</sup> / <sub>8</sub>	5 <sup>8</sup> / <sub>8</sub> / 5 <sup>8</sup> / <sub>8</sub>	7 <sup>8</sup> / <sub>8</sub>	5 <sup>8</sup> / <sub>8</sub> / 5 <sup>8</sup> / <sub>8</sub>	7 <sup>8</sup> / <sub>8</sub>
<b>MAXIMUM HEIGHT FOR 1.7° C SUBCOOLING (m)†</b>	23	23	23	23	23	23	23	23	23	23
<b>CAPACITY PER CIRCUIT (%) (CKT A/CKT B)</b>	50/50	100	50/50	100	50/50	100	54/46	100	48/52	100
<b>MINIMUM UNIT CAPACITY (%)</b>										
Standard Compressor	50	50	50	50	50	50	27	33	23	33
Digital Compressor	17	17	17	17	17	17	13	16	11	16

### LEGEND

**MCHX** — Microchannel Heat Exchanger  
**ODF** — Outside Diameter, Female

\*Typical operating charge with 7.62 m of interconnecting piping. Operating charge is approximate for maximum system capacity. Unit is factory supplied with nitrogen holding charge. Refrigerant charge for dual circuit units is the total for both circuits.

†Maximum vertical separation between evaporator coil and condensing unit.

NOTE: Refer to Loading Sequences tables in Application Data section on page 92 or contact Application Engineering for detailed capacity step data.



### 38AP060-130 UNITS — SI

38AP UNIT SIZES	060	065	070	080	090	100	115	130
<b>NOMINAL CAPACITY 50/60 Hz (kW)</b>	176/211	190/228	205/246	234/281	264/316	293/351	337/404	381/457
<b>CIRCUIT</b>	Dual	Single	Dual	Dual	Dual	Dual	Dual	Dual
<b>OPERATING WEIGHTS (kg)</b>								
Standard	1010	1058	1111	1184	1286	1290	1456	1521
With Low Sound Option	1043	1083	1144	1225	1335	1339	1505	1570
<b>REFRIGERANT CHARGE (kg)</b>								
Total*	25	25	28	34	39	42	46	53
Circuit A/Circuit B	12/13	—/25	13/15	13/21	18/21	21/21	21/25	21/32
<b>NITROGEN SHIPPING CHARGE</b>	1.03 bar							
<b>COMPRESSOR kW (Qty) (CKT A/CKT B)</b>	9.7 (2)/ 11.2 (2)	15.0 (3)	11.2 (2)/ 8.2 (3)	11.2 (2)/ 11.2 (3)	9.7 (3)/ 11.2 (3)	11.2 (3)/ 11.2 (3)	11.2 (3)/ 15.0 (3)	11.2 (3)/ 18.6 (3)
<b>CAPACITY STEPS</b>								
Standard	4	3	5	5	6	6	6	6
Digital Option	36	—	45	45	54	54	54	54
<b>CRANKCASE HEATER (W) (each compressor)</b>	90 (60/50 Hz)						90 CKT A, 120 CKT B (60/50 Hz)	
<b>CONDENSER FANS</b>	Propeller Type, Axial, Vertical Discharge							
Standard	Quantity							
Quantity	4	4	4	5	6	6	7	8
r/s	19 (60 Hz), 16 (50 Hz)							
Diameter (mm)	762							
Total Watts (60 Hz)	6200	6000	6000	7500	9000	9000	10500	12000
Total Watts (50 Hz)	3751	3630	3630	4538	5445	5445	6353	7260
Low Noise	Plastic Type, Axial, Vertical Discharge							
Quantity	4	4	4	5	6	6	7	8
r/s	14 (60 Hz), 12 (50 Hz)							
Diameter (mm)	762							
Total Watts (60 Hz)	5200	5000	5000	6250	7500	7500	8750	10000
Total Watts (50 Hz)	3146	3025	3025	3781	4538	4538	5294	6050
<b>CONDENSER COIL</b>	MCHX Type							
No. Coils per Circuit	1	3	2	2 to 3	3	3	3 to 4	3 to 5
sq m	6.3	6.9	9.3	11.6	13.9	13.9	16.2	18.5
<b>TEMPERATURE RELIEF</b>	Fusible Plug on Liquid Lines of Each Circuit - 99 C							
<b>CONNECTIONS (in.) ODF (CKT A/CKT B)</b>	Suction Line							
Suction Line	1 <sup>5</sup> / <sub>8</sub> / 1 <sup>5</sup> / <sub>8</sub>	2 <sup>5</sup> / <sub>8</sub>	1 <sup>5</sup> / <sub>8</sub> / 2 <sup>1</sup> / <sub>8</sub>	1 <sup>5</sup> / <sub>8</sub> / 2 <sup>1</sup> / <sub>8</sub>	2 <sup>1</sup> / <sub>8</sub> / 2 <sup>1</sup> / <sub>8</sub>	2 <sup>1</sup> / <sub>8</sub> / 2 <sup>1</sup> / <sub>8</sub>	2 <sup>1</sup> / <sub>8</sub> / 2 <sup>5</sup> / <sub>8</sub>	2 <sup>1</sup> / <sub>8</sub> / 2 <sup>5</sup> / <sub>8</sub>
Liquid Line	5 <sup>8</sup> / <sub>8</sub> / 5 <sup>8</sup> / <sub>8</sub>	7 <sup>8</sup> / <sub>8</sub>	7 <sup>8</sup> / <sub>8</sub> / 7 <sup>8</sup> / <sub>8</sub>	7 <sup>8</sup> / <sub>8</sub> / 7 <sup>8</sup> / <sub>8</sub>	7 <sup>8</sup> / <sub>8</sub> / 7 <sup>8</sup> / <sub>8</sub>	7 <sup>8</sup> / <sub>8</sub> / 7 <sup>8</sup> / <sub>8</sub>	7 <sup>8</sup> / <sub>8</sub> / 7 <sup>8</sup> / <sub>8</sub>	7 <sup>8</sup> / <sub>8</sub> / 1 <sup>1</sup> / <sub>8</sub>
<b>MAXIMUM HEIGHT FOR 1.7° C SUBCOOLING (m)†</b>	23	23	23	23	23	23	23	23
<b>CAPACITY PER CIRCUIT (%) (CKT A/CKT B)</b>	46/54	100	47/53	40/60	46/54	50/50	44/56	38/62
<b>MINIMUM UNIT CAPACITY (%)</b>								
Standard Compressor	23	33	24	20	15	17	14	13
Digital Compressor	11	—	11	9	7	8	7	6

**LEGEND**

**MCHX** — Microchannel Heat Exchanger  
**ODF** — Outside Diameter, Female

\*Typical operating charge with 7.62 m of interconnecting piping. Operating charge is approximate for maximum system capacity. Unit is factory supplied with nitrogen holding charge. Refrigerant charge for dual circuit units is the total for both circuits.

†Maximum vertical separation between evaporator coil and condensing unit.

NOTE: Refer to Loading Sequences tables in Application Data section on page 92 or contact Application Engineering for detailed capacity step data.

# Options and accessories



ITEM	FACTORY-INSTALLED OPTION	FIELD-INSTALLED ACCESSORY
<b>Condenser Coil/Low Sound Options</b>		
E-Coated MCHX	X	
Low Sound Fan(s)	X	X
Low Sound Compressor Blankets	X	X
Vibration Isolation Pads		X
<b>Line Length Options</b>		
Long Line Length Check Valve	X	X
<b>Ambient/Capacity Control/High SCCR Options</b>		
Digital Compressor*	X	
High Short Circuit Current Rating (SCCR)	X	
Motormaster® V Low Ambient Control	X	X
<b>Electrical Options</b>		
Dual Point Power (sizes 115 and 130 only)	X	
Non-Fused Disconnect	X	
<b>Controls/Communications Options</b>		
Navigator™ Display		X
Remote Enhanced Display		X
Touch Pilot™ Display		X
EMM	X	X
BACnet Communication	X	
BACnet Translator Control		X
LON Translator Control		X
<b>Packaging/Security Options</b>		
Bottom Skid	X	
Top Crate, Bag	X	
Security Grilles/Hail Guards	X	X
Wind Baffles		X

## LEGEND

- E-Coated** — Epoxy Coating Applied to Entire Coil Assembly
- EMM** — Energy Management Module
- LON** — Local Operating Network
- MCHX** — Microchannel Heat Exchanger

\*Digital compressors provide incremental unloading from full capacity down to a minimum value. Not available on size 065 unit.

## NOTES:

1. Std SCCR (short circuit current rating) (5 kA)
2. High SCCR 460-v and 380/415-v (65 kA), 208/230-v (65 kA), 575-v (25 kA)

## Factory-installed options

**E-coated Novation® heat exchanger technology microchannel coil (aluminum fin/aluminum tube) condenser** is available for optimum durability. Novation heat exchangers with microchannel coil technology are offered coated or uncoated to match coil protection to site conditions. The Carrier Electronic Catalog (E-Cat) can be used to determine whether or not corrosion protection is recommended for particular applications in coastal/marine environments. Following the input of the requested data, the E-Cat program output will advise the appropriate coil to be used. Other factors described in “Selection Guide: Environmental Corrosion Protection, Condenser Coils and Cooling/Heating Coils for Commercial Products” catalog number 04-581061-01 must also be considered to determine if corrosion protection is required.

**Low sound fans** provide a specially designed system of fan propellers and stacks that reduce sound without reducing unit performance. The factory-installed fan option is compatible with the Motormaster® V option. Low sound fans are also available as field-installed accessory.

**Low sound compressor blankets** reduce unit sound levels by providing an acoustic blanket on each compressor. Compressor blankets are also available as field-installed accessory.

**Security grilles/hail guards** consist of louvered, sheet metal panels which securely fasten to the unit and provide condenser coil protection against hail and physical damage. Security grilles/hail guards are also available as field-installed accessories.

**Long line length check valves** are required for liquid line installation on all linear line length applications of more than 100 ft (30.5 m). For any 025-030 size dual-circuit unit application where evaporator is located higher than the condensing unit, check valves are required for linear line length above 55 ft (16.8 m). The check valve option prevents charge migration to compressor. As an option, the check valves are shipped with the unit but require field installation. Check valves are also available as field-installed accessories shipped separately from the unit.

**Digital compressor control** allows incremental unloading for a closer match to building load, improved compressor reliability in the reduced compressor cycling, and improved efficiency as compared to hot gas bypass and other modulating methods. Refer to Loading Sequences table in Application Data section on page 92. Digital compressor option is not available on unit size 065.

**High short circuit current rating (SCCR) interrupt** provides a short circuit current rating protection for the unit up to 65 kA on 460-v, 380/415-v, and 208/230-v units or 25 kA on 575-v units. The high SCCR option is available with either a terminal block or a non-fused disconnect for unit sizes 38AP025-070 at 460-v or 575-v. Other unit sizes and voltages require the selection of the non-fused disconnect in order to obtain the high SCCR option. See the High SCCR Availability table on page 11.

## HIGH SCCR AVAILABILITY

UNIT VOLTAGE	38AP UNIT SIZE			
	025-070		080-130	
	NON-FUSED DISCONNECT	TERMINAL BLOCK	NON-FUSED DISCONNECT	TERMINAL BLOCK
208/230-3-60	X	—	X	—
380-3-60	X	—	X	—
380/415-3-50	X	—	X	—
460-3-60	X	X	X	—
575-3-60	X	X	X	—

**Motormaster V low-ambient control** provides control of outdoor-fan motor operation to maintain head pressure at low outdoor ambient temperatures down to  $-20^{\circ}\text{F}$  ( $-29^{\circ}\text{C}$ ) for 50 and 60 Hz units. Only one factory-installed low ambient temperature kit per unit is required. This option also requires field-installed wind baffles. The Motormaster V low-ambient control is also available as a field-installed accessory.

**Dual point power connection** option is provided with terminal blocks for size 115 and 130 units.

**Non-fused disconnect** includes factory-installed non-fused disconnect capability for power and control located at the unit.

**Packaging options** include bottom skid with standard coil protection and bottom skid, top crate with bag. Standard coil protection is also included on all unit packaging.

**Energy management module (EMM)** provides energy management capabilities to minimize condensing unit energy consumption. The EMM is also available as a field-installed accessory.

**BACnet communication option** provides factory-installed communication capability with a BACnet MS/TP network. Allows integration with i-Vu<sup>®</sup> Open control system or a BACnet building automation system.

### Field-installed accessories

**Vibration isolation pads** reduce vibration transmission from the compressor through the floor and into the conditioned space. The neoprene isolator pads measure  $\frac{1}{4}$  in. thick (24 in. x 3 in.).

**Long line length check valves** are required for liquid line installation on all linear line length applications of more than 100 ft (30.5 m). For any 025-030 size dual-circuit unit application where evaporator is located higher than the condensing unit, check valves are required for linear line length above 55 ft (16.8 m). The check valve option prevents charge migration to compressor. Field installation is required. Check valves are also available as an option that ships with the unit.

**Motormaster<sup>®</sup> V low-ambient control** provides control of outdoor-fan motor operation to maintain head pressure at low outdoor ambient temperatures down to  $-20^{\circ}\text{F}$  ( $-29^{\circ}\text{C}$ ) for 50 and 60 Hz units. Only one field-installed low ambient temperature kit per unit is required. This accessory also requires field-installed wind baffles. The Motormaster V low-ambient control is also available as a factory-installed option.

**Navigator<sup>™</sup> display module** provides a portable, hand held display module for convenient access to unit status, operation, configuration and troubleshooting diagnostics capability. The 4-line, 80-character LCD (liquid crystal display) display provides clear language information in English, French, Spanish or Portuguese. The weatherproof enclosure and industrial grade extension cord make the Navigator module ideally suited for outdoor applications. Magnets located on the back of the module allow attachment to any sheet metal component for hands-free operation.

**Energy management module** provides energy management capabilities to minimize condensing unit energy consumption. The EMM is also available as a factory-installed option.

**BACnet translator control** provides an interface between the unit and a BACnet Local Area Network (LAN, i.e., MS/TP EIA-485).

**LON (local operating network) translator control** provides an interface between the unit and a local operating network (i.e., LonWorks<sup>®</sup> FT-10A ANSI/EIA-709.1).

**Remote enhanced display** accessory kit contains a remotely mounted 40-character per line, 16-line display panel for unit diagnostics.

**Touch Pilot<sup>™</sup> display** is a cost-effective, touch-screen, remote-mount device that can be used in lieu of the remote enhanced display.

**Low sound compressor blankets** reduce unit sound levels by providing an acoustic blanket on each compressor. Compressor blankets are also available as factory-installed option.

**Security grilles/hail guards** consist of louvered, sheet metal panels which securely fasten to the unit and provide condenser coil protection against hail and physical damage. Security grilles/hail guards are also available as a factory-installed option.

**Low sound fans** provide a specially designed system of fan propellers and stacks that reduce sound without reducing unit performance. The field-installed fan accessory is compatible with the Motormaster V option. Low sound fans are also available as factory-installed option.

**Wind baffles** facilitate operation down to  $-20^{\circ}\text{F}$  ( $-29^{\circ}\text{C}$ ) when used in conjunction with low ambient temperature head pressure control. Use of wind baffles alone, without the use of Motormaster V low-ambient control, does not reduce the minimum standard ambient values.

\*Registered trademark of Echelon Corporation.

## 38AP025-030 UNITS

UNIT	STANDARD WEIGHT, lb (kg)	CENTER OF GRAVITY, in. (mm)		HEIGHT, in. (mm)	POWER ENTRY, in. (mm)	SERVICE VALVE CONNECTIONS, in. (mm)	
		X	Y			Suction	Liquid
Standard	38APS025	1077 (489)	17.8 (452)	36.9 (937)	24.9 (632)	1 5/8 (41)	5/8 (16)
	38APD025	1095 (497)	17.8 (452)	37.0 (940)		1 3/8 (35)	5/8 (16)
	38APS027	1240 (563)	18.2 (462)	37.6 (955)	36.9 (937)	1 5/8 (41)	5/8 (16)
	38APD027	1258 (571)	18.2 (462)	37.6 (955)		1 5/8 (41)	7/8 (22)
	38APS030	1246 (565)	18.2 (462)	37.5 (953)	24.9 (632)	1 3/8 (35)	5/8 (16)
	38APD030	1264 (573)	18.2 (462)	37.6 (955)		1 5/8 (41)	5/8 (16)
Low Sound	38APS025	1113 (505)	17.8 (452)	36.9 (937)	36.9 (937)	1 5/8 (41)	5/8 (16)
	38APD025	1131 (513)	17.8 (452)	37.0 (940)		1 3/8 (35)	5/8 (16)
	38APS027	1276 (579)	18.2 (462)	37.6 (955)	78.6 (1996)	1 5/8 (41)	5/8 (16)
	38APD027	1294 (587)	18.2 (462)	37.6 (955)		1 5/8 (41)	7/8 (22)
	38APS030	1282 (582)	18.2 (462)	37.5 (953)	24.9 (632)	1 3/8 (35)	5/8 (16)
	38APD030	1300 (590)	18.2 (462)	37.6 (955)		1 5/8 (41)	5/8 (16)

### NOTES:

- Be sure to use a wet rag and remove all valve cores before brazing field piping.
- Do not cap or otherwise obstruct the liquid line temperature relief.
- A 7/8 in. (22.4 mm) diameter hole is provided for locating field power wiring. Actual hole size required depends on field wire sizing.
- A 0.437 in. (11.1 mm) diameter hole is used for mounting unit.
- Unit must have clearances as follows:  
Top - Do not restrict.  
Coil End - 42 in. (1067 mm) from solid surface for airflow.  
Panel Side - 48 in. (1219 mm) per NEC (National Electrical Code).
- Unit height (dimension H) for the low sound fan option includes the fan stack.
- Installation in a pit is not recommended.
- Unit can be handled using the fork truck lift pockets.
- Dimensions shown in inches (mm).
- Weight does not include unit refrigerant charge.
- For 38APS piping, refer to Circuit A Liquid Connection and Circuit A Suction Connection dimensions shown.

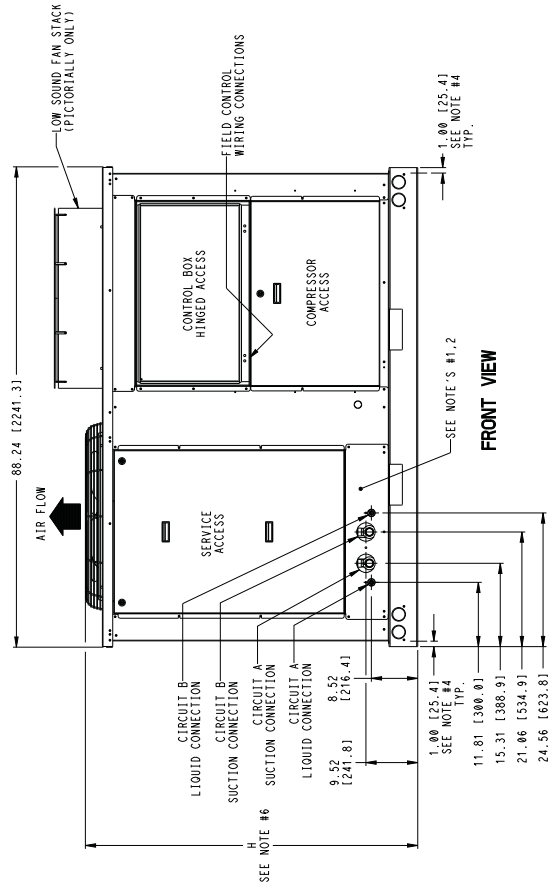
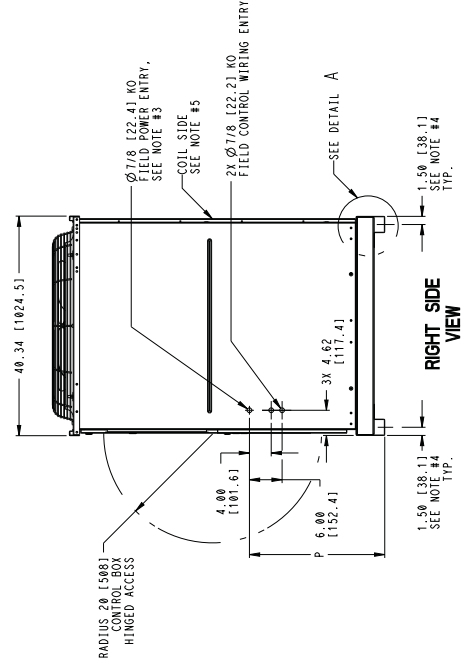
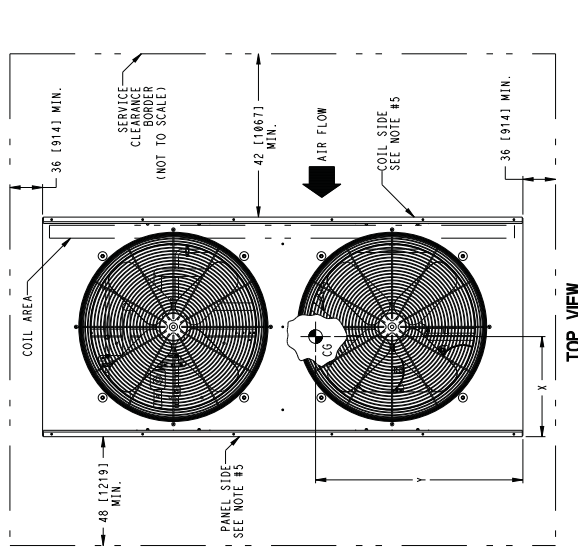
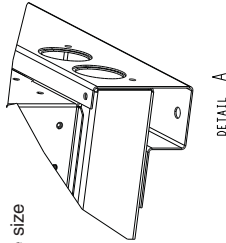

### 38AP040-060 UNITS

**NOTES:**

1. Be sure to use a wet rag and remove all valve cores before brazing field piping.
2. Do not cap or otherwise obstruct the liquid line temperature relief.
3. A  $7/8$  in. (22.4 mm) diameter hole is provided for locating field power wiring. Actual hole size required depends on field wire sizing.
4. A 0.437 in. (11.1 mm) diameter hole is used for mounting unit.
5. Unit must have clearances as follows:  
Top - Do not restrict.  
Coil End - 42 in. (1067) from solid surface for airflow.  
Panel Side - 48 in. (1219) per NEC (National Electrical Code).
6. Unit height (dimension H) for the low sound fan option includes the fan stack.
7. Installation in a pit is not recommended.
8. Unit can be handled using the fork truck lift pockets.
9. Dimensions shown in inches (mm).
10. Sizes 040 and 050 units have 3 condenser fans. Size 060 units have 4 condenser fans.
11. Weight does not include unit refrigerant charge.
12. For 38APS piping, refer to Circuit A Liquid Connection and Circuit A Suction Connection dimensions shown.

UNIT	STANDARD WEIGHT, lb (kg)	CENTER OF GRAVITY, in. (mm)		HEIGHT, in. (mm)	SERVICE VALVE CONNECTIONS, in. (mm)	
		X	Y		Suction	Liquid
Standard	38APS040	1968 (893)	35.0 (869)	44.0 (1118)	$2\frac{1}{8}$ (54)	$7/8$ (22)
	38APD040	2094 (950)	33.7 (856)	44.1 (1120)	$1\frac{5}{8}$ (41)	$5/8$ (16)
	38APS050	1977 (897)	34.9 (886)	44.0 (1118)	$2\frac{1}{8}$ (54)	$7/8$ (22)
	38APD050	2120 (961)	33.4 (848)	44.1 (1120)	$1\frac{5}{8}$ (41)	$5/8$ (16)
Low Sound	38APD060	2227 (1010)	34.4 (874)	44.1 (1120)	$1\frac{5}{8}$ (41)	$5/8$ (16)
	38APS040	2022 (917)	35.0 (869)	44.0 (1118)	$2\frac{1}{8}$ (54)	$7/8$ (22)
	38APD040	2148 (974)	33.7 (856)	44.1 (1120)	$1\frac{5}{8}$ (41)	$5/8$ (16)
	38APS050	2031 (921)	34.9 (886)	44.0 (1118)	$2\frac{1}{8}$ (54)	$7/8$ (22)
38APD050	2174 (986)	33.4 (848)	44.1 (1120)	$1\frac{5}{8}$ (41)	$5/8$ (16)	
38APD060	2299 (1043)	34.4 (874)	44.1 (1120)	$1\frac{5}{8}$ (41)	$5/8$ (16)	

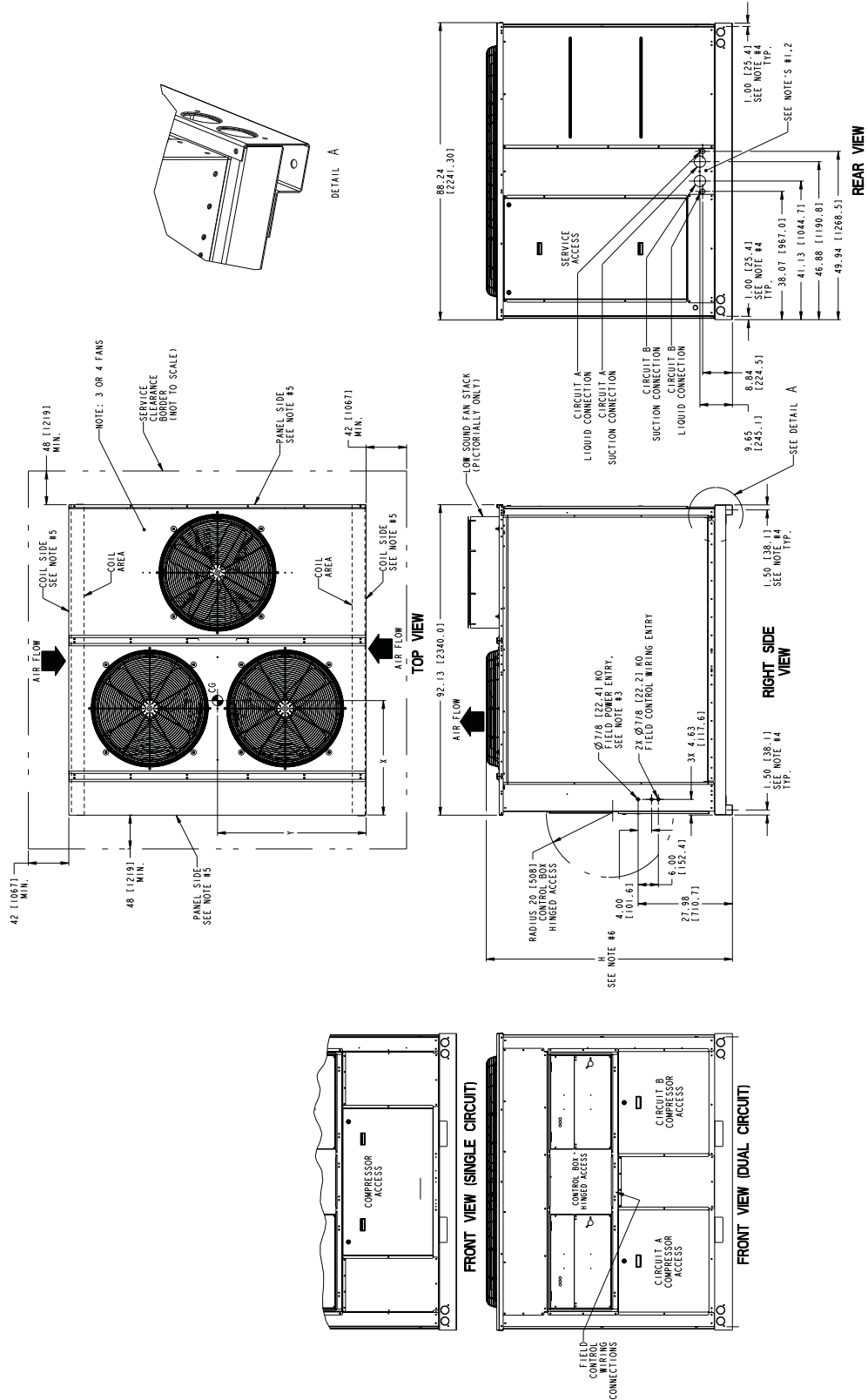



# Dimensions (cont)

## 38AP065,070 UNITS

UNIT	STANDARD WEIGHT, lb (kg)	CENTER OF GRAVITY, in. (mm)		HEIGHT, in. (mm)	SERVICE VALVE CONNECTIONS, in. (mm)				SERVICE VALVE LOCATIONS CIRCUIT B ONLY, in. (mm)	
		X			Y		Suction		Suction	
		X	Y		Circuit A	Circuit B	Liquid	S1	S2	
<b>Standard</b>	2333 (1058)	36.2 (919)	43.6 (1108)	73.0 (1854)	—	2 <sup>5</sup> / <sub>8</sub> (67)	7/8 (22)	9.26 (235.2)	20.81 (528.6)	
	2450 (1111)	50.9 (1293)	40.6 (1031)	73.0 (1854)	1 <sup>5</sup> / <sub>8</sub> (41)	2 <sup>1</sup> / <sub>8</sub> (54)	7/8 (22)	12.85 (326.4)	14.04 (356.6)	
<b>Low Sound</b>	2387 (1083)	36.2 (919)	43.6 (1108)	78.5 (1994)	—	2 <sup>5</sup> / <sub>8</sub> (67)	7/8 (22)	9.26 (235.2)	20.81 (528.6)	
	2522 (1144)	50.9 (1293)	40.6 (1031)	78.5 (1994)	1 <sup>5</sup> / <sub>8</sub> (41)	2 <sup>1</sup> / <sub>8</sub> (54)	7/8 (22)	12.85 (326.4)	14.04 (356.6)	

**NOTES:**

1. Be sure to use a wet rag and remove all valve cores before brazing field piping.
2. Do not cap or otherwise obstruct the liquid line temperature relief.
3. A 7/8 in. (22.4 mm) diameter hole is provided for locating field power wiring. Actual hole size required depends on field wire sizing.
4. A 0.524 in. (13.309 mm) diameter hole is used for mounting unit.
5. Unit must have clearances as follows:  
 Top - Do not restrict.  
 Panel Side - 48 in. (1219 mm) per NEC.  
 Sides and End - 6 ft. (1828.8 mm) from solid surface for airflow.  
 Sides - 8 ft. (2438.4 mm) required for coil service area.  
 Coil End - 42 in. (1067 mm) from solid surface for airflow.
6. Unit height (dimension H) for the low sound fan option includes the fan stack.
7. Installation in a pit is not recommended.
8. Unit can be handled using crane. Refer to service installation instructions.
9. Dimensions shown in inches (mm).
10. Weight does not include refrigerant charge.

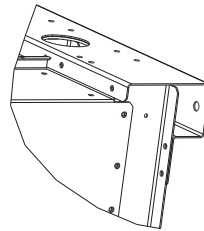
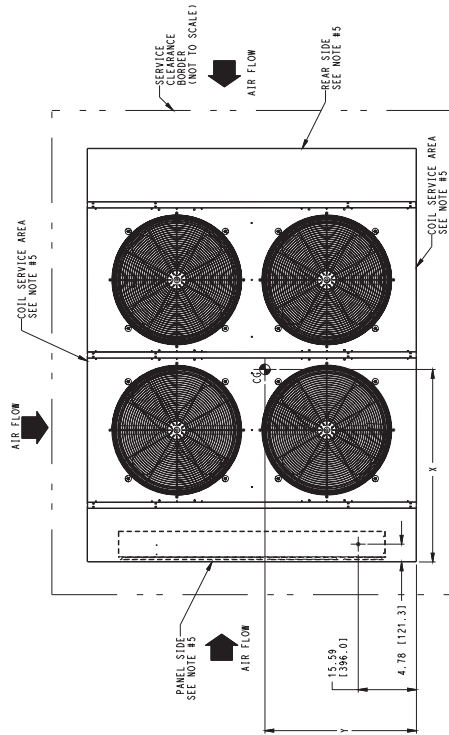

DETAIL A

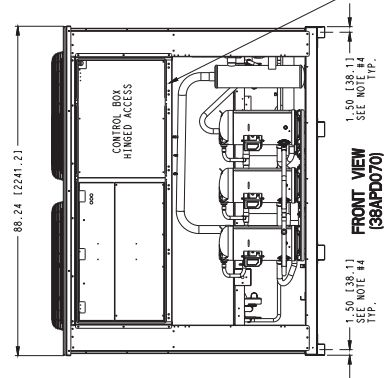
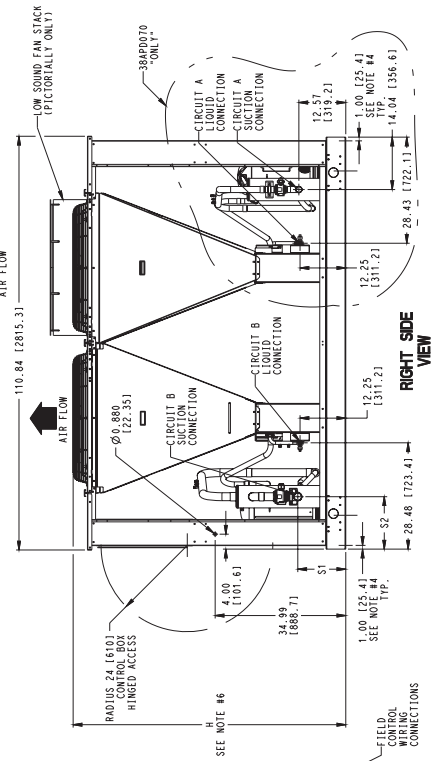

FRONT VIEW (38APD070)

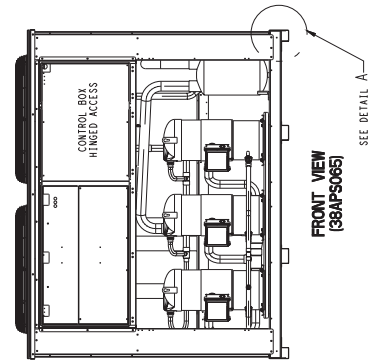

FRONT VIEW (38APS065)

### 38AP080-100 UNITS

UNIT	STANDARD WEIGHT, lb (kg)	CENTER OF GRAVITY, in. (mm)		HEIGHT, in. (mm)	SERVICE VALVE CONNECTIONS, in. (mm)		
		X	Y		Suction	Circuit A	Circuit B
Standard	38APD080	2610 (1184)	67.6 (1716)	40.2 (1020)	1 5/8 (41)	2 1/8 (54)	7/8 (22)
	38APD090	2835 (1286)	72.4 (1839)	43.3 (1099)	2 1/8 (54)	2 1/8 (54)	7/8 (22)
	38APD100	2844 (1290)	72.6 (1844)	43.3 (1099)	2 1/8 (54)	2 1/8 (54)	7/8 (22)
Low Sound	38APD080	2700 (1225)	67.6 (1716)	40.2 (1020)	1 5/8 (41)	2 1/8 (54)	7/8 (22)
	38APD090	2943 (1335)	72.4 (1839)	43.3 (1099)	2 1/8 (54)	2 1/8 (54)	7/8 (22)
	38APD100	2952 (1339)	72.6 (1844)	43.3 (1099)	2 1/8 (54)	2 1/8 (54)	7/8 (22)

**NOTES:**

- Be sure to use a wet rag and remove all valve cores before brazing field piping.
- Do not cap or otherwise obstruct the liquid line temperature relief.
- A 7/8 in. (22.4 mm) diameter hole is provided for locating field power wiring. Actual hole size required depends on field wire sizing.
- A 0.524 in. (13.309 mm) diameter hole is used for mounting unit.
- Unit must have clearances as follows:
  - Top - Do not restrict.
  - Panel Side - 48 in. (1219 mm) per NEC.
  - Sides and End - 6 ft. (1228.8 mm) from solid surface for airflow.
  - Sides - 8 ft. (2438.4 mm) required for coil service area.
  - Coil End - 42 in. (1067 mm) from solid surface for airflow.
- Unit height (dimension H) for the low sound fan option includes the fan stack.
- Installation in a pit is not recommended.
- Unit can be handled using crane. Refer to service installation instructions.
- Dimensions shown in inches (mm).
- Size 080 units have 5 condenser fans. Sizes 090 and 100 have 6 condenser fans.
- Weight does not include unit refrigerant charge.

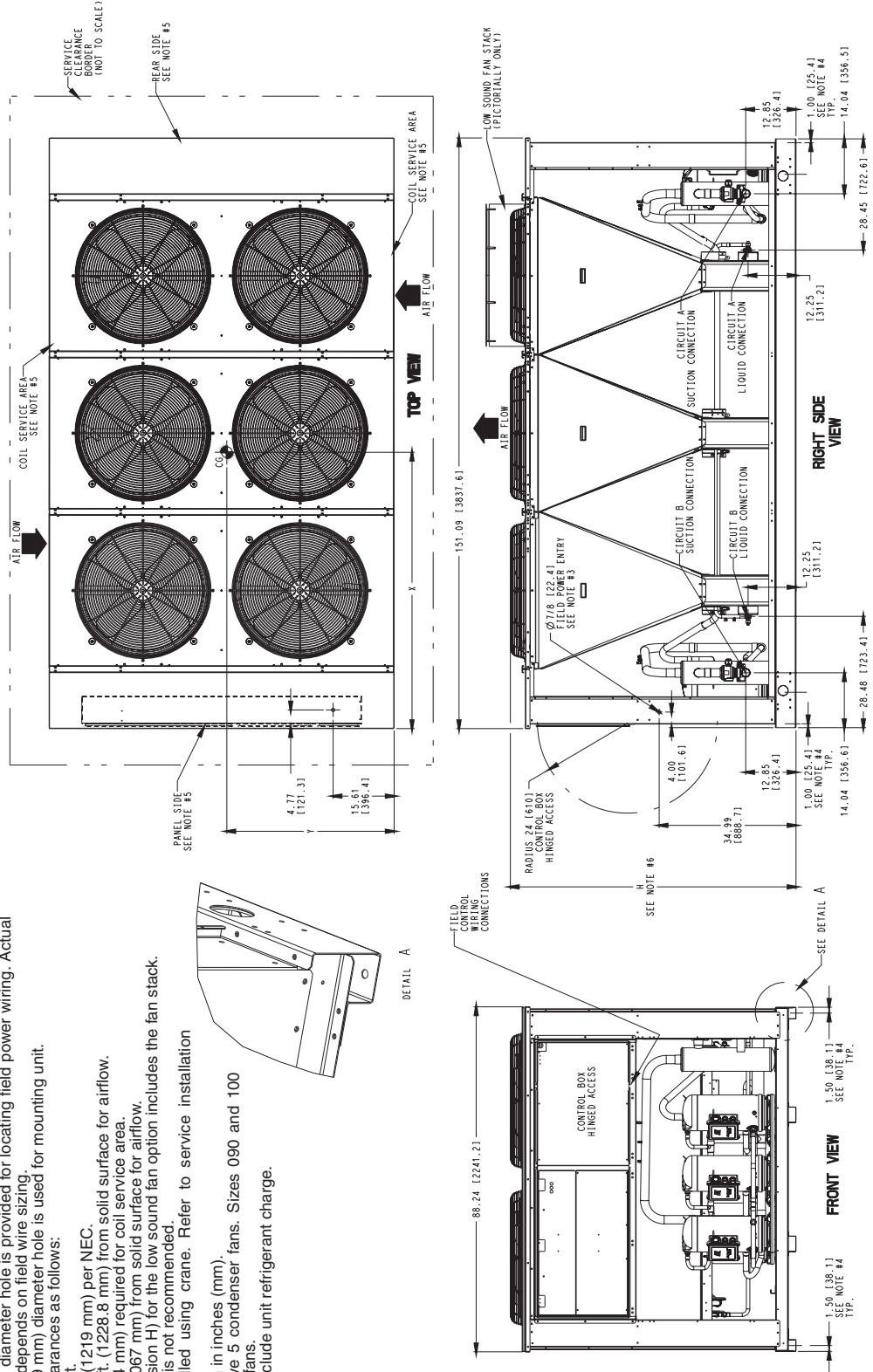



# Dimensions (cont)

## 38AP115,130 UNITS

UNIT	STANDARD WEIGHT, lb (kg)	CENTER OF GRAVITY, in. (mm)		HEIGHT, in. (mm)	SERVICE VALVE CONNECTIONS, in. (mm)				SERVICE VALVE LOCATIONS CIRCUIT B ONLY, in. (mm)	
		X	Y		Suction	Liquid	L1	L2		
Standard	38APD115	3211 (1457)	71.1 (1806)	44.4 (1128)	Circuit A	Circuit B	Circuit A	Circuit B	L1	L2
	38APD130	3353 (1521)	70.9 (1801)	44.6 (1133)	2 1/8 (54)	2 5/8 (67)	7/8 (22)	7/8 (22)	28.48 (723)	12.25 (311)
Low Sound	38APD115	3319 (1506)	71.1 (1806)	44.4 (1128)	2 1/8 (54)	2 5/8 (67)	7/8 (22)	7/8 (22)	28.36 (720)	11.97 (304)
	38APD130	3461 (1570)	70.9 (1801)	44.6 (1133)	2 1/8 (54)	2 5/8 (67)	7/8 (22)	7/8 (22)	28.48 (723)	12.25 (311)

### NOTES:

1. Be sure to use a wet rag and remove all valve cores before brazing field piping.
2. Do not cap or otherwise obstruct the liquid line temperature relief.
3. A 7/8 in. (22.4 mm) diameter hole is provided for locating field power wiring. Actual hole size required depends on field wire sizing.
4. A 0.437 in. (11.1 mm) diameter hole is used for mounting unit.
5. Unit must have clearances as follows:  
Top - Do not restrict.  
Panel Side - 48 in. (1219 mm) per NEC.  
Sides and End - 6 ft. (1828.8 mm) from solid surface for airflow.  
Sides - 8 ft. (2438 mm) required for coil service area.  
Coil End - 42 in. (1067 mm) from solid surface for airflow.  
Coil height (dimension H) for the low sound fan option includes the fan stack.
6. Unit height (dimension H) for the low sound fan option includes the fan stack.
7. Installation in a pit is not recommended.
8. Unit can be handled using crane. Refer to service installation instructions.
9. Dimensions shown in inches (mm).
10. Weight does not include unit refrigerant charge.
11. Size 115 units have 7 condenser fans. Size 130 units have 8 condenser fans.

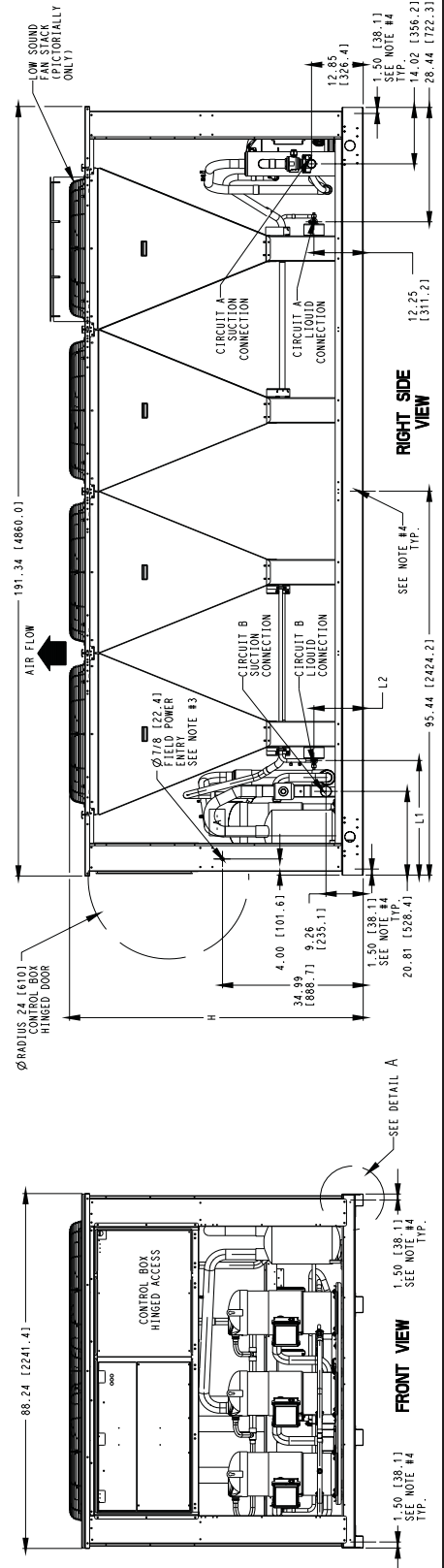
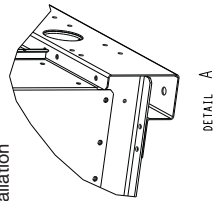
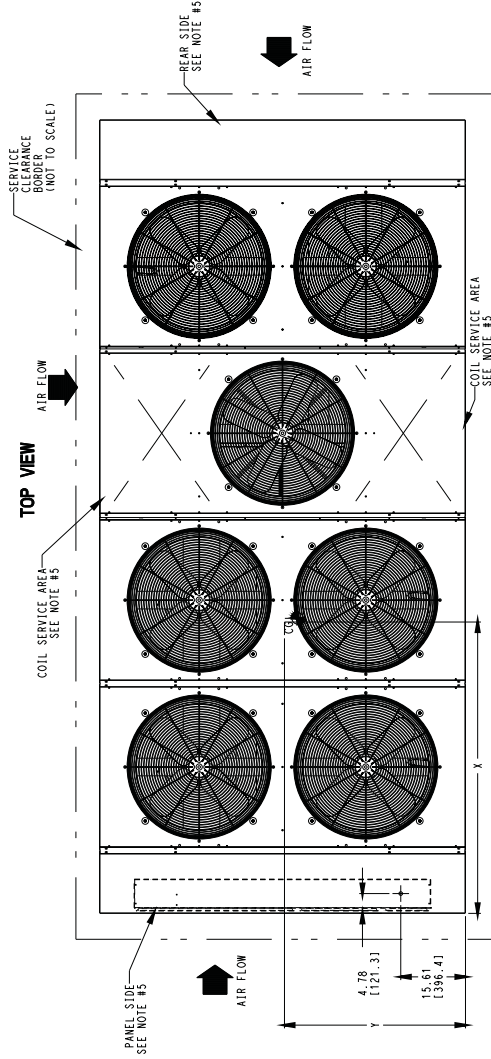

# Selection procedure



## To select a 38AP stand-alone condensing unit:

Use Carrier's **Commercial Split Builder** program to select a stand-alone outdoor unit from the Installation Configuration drop down menu and input the job requirements. From the list presented, select a 38AP condensing unit that is estimated to meet capacity requirements. The 38APS single-circuit unit is offered in sizes 025-065 and the 38APD dual-circuit unit is offered in sizes 025-130. After a 38AP unit is selected, the program will calculate the condensing unit performance.

## To select 38AP systems:

**For systems with one 40RU fan coil unit or 39 Series air handler** — Use Carrier's **Commercial Split Builder** program to select a combined 38AP outdoor unit with matched 40RU indoor unit for sizes 025-030. The **AHUBuilder**<sup>®</sup> selection program is available to select 38AP outdoor units with a matching 39 Series air handler with direct-expansion (DX) coils. The 38APS single-circuit unit is offered in sizes 025-065 and 38APD dual-circuit unit is offered in sizes 025-130. Enter the software program and input the job requirements. From the list presented, select a 38AP condensing unit that is estimated to meet capacity requirements. After selecting a 38AP unit, check its performance with one or several DX coils. From the DX coil list presented on the screen, match the 38AP with any coil or all coils. The program calculates

the combined performance of the condensing unit and each DX coil and presents the resulting system capacities and operating temperatures. Matching thermostatic expansion valves and nozzles for the DX coils are automatically selected and displayed.

**For systems with two air handlers** — Use Carrier's **AHUBuilder**<sup>®</sup> selection program to select one size 025-130 38AP outdoor unit to match with two 39 Series air handlers with DX coils. For the first air handler, enter the **AHUBuilder** selection program and input the job requirements. To choose a condensing unit, select the Specify Your Own option. The program asks for condensing unit capacities and SDT (saturated discharge temperature) at 30 F (–1.1 C) and 50 F (10 C) SST (saturated suction temperature). The SDT must first be determined by running a standalone outdoor unit in the **Commercial Split Builder** program. The circuit capacity is listed in the Condensing Unit Circuit Ratings tables on pages 22-27, 33-44, 49-54, and 60-71. Enter the capacities from condenser circuit A or B and SDT for circuits A and B into the **AHUBuilder** program (remember to use the correct air temperature entering condenser column when locating the circuit capacities). For the second air handler, repeat the procedure to select the second DX coil for the condenser circuit (A or B) not used in the first selection.

# Performance data



## 38APD,APS025 CONDENSING UNIT RATINGS, 60 Hz ENGLISH

SST (F)*		CONDENSER ENTERING-AIR TEMPERATURE (F)										
		70	80	85	90	95	100	105	110	115	120	125
30	TC	250.0	241.8	233.3	225.4	217.4	209.2	201.0	192.6	184.1	176.2	168.0
	kW	17.2	18.4	19.6	20.6	21.7	22.8	24.0	25.1	26.3	27.4	28.5
35	TC	275.6	266.8	257.7	249.2	240.6	231.9	223.0	214.0	204.7	196.3	187.5
	kW	17.5	18.6	19.9	20.9	22.0	23.2	24.3	25.5	26.8	27.8	29.0
40	TC	302.0	292.5	282.6	273.5	264.2	254.8	245.3	235.6	225.7	216.6	207.1
	kW	18.1	19.2	20.5	21.6	22.8	23.8	25.0	26.2	27.5	28.6	29.8
45	TC	328.2	318.0	307.3	297.5	287.5	277.4	267.1	256.6	245.9	236.1	225.9
	kW	18.1	19.2	20.5	21.6	22.8	23.8	25.0	26.2	27.5	28.6	29.8
50	TC	353.7	342.7	331.2	320.5	309.6	298.6	287.5	276.1	264.6	253.9	242.9
	kW	18.4	19.6	20.9	21.9	23.0	24.2	25.4	26.6	27.8	28.9	30.1

## 38APD,APS027 CONDENSING UNIT RATINGS, 60 Hz ENGLISH

SST (F)*		CONDENSER ENTERING-AIR TEMPERATURE (F)										
		70	80	85	90	95	100	105	110	115	120	125
30	TC	282.5	274.2	265.6	257.5	249.3	241.0	232.6	224.2	215.5	207.4	199.1
	kW	19.2	20.4	21.8	23.0	24.1	25.4	26.7	28.0	29.5	30.6	31.8
35	TC	309.6	300.5	291.1	282.3	273.4	264.4	255.2	245.9	236.4	227.6	218.5
	kW	19.7	20.9	22.4	23.5	24.7	25.9	27.2	28.5	30.0	31.1	32.3
40	TC	336.9	327.1	316.8	307.3	297.6	287.8	277.9	267.8	257.5	248.0	238.1
	kW	20.9	22.1	23.5	24.6	25.8	27.0	28.3	29.6	31.0	32.1	33.3
45	TC	364.2	353.5	342.4	332.0	318.6	310.8	300.0	289.0	277.9	267.5	256.8
	kW	20.9	22.1	23.5	24.6	25.8	27.0	28.3	29.6	31.0	32.1	33.3
50	TC	391.3	379.6	367.6	356.2	344.7	333.1	321.4	309.5	297.4	286.1	274.4
	kW	21.5	22.8	24.2	25.2	26.4	27.6	28.9	30.2	31.6	32.6	33.9

## 38APD,APS030 CONDENSING UNIT RATINGS, 60 Hz ENGLISH

SST (F)*		CONDENSER ENTERING-AIR TEMPERATURE (F)										
		70	80	85	90	95	100	105	110	115	120	125
30	TC	328.8	319.4	309.6	300.5	291.2	281.9	272.5	262.8	253.0	243.9	234.5
	kW	23.1	24.7	26.5	27.9	29.3	30.9	32.5	34.2	36.0	37.4	39.0
35	TC	359.8	349.6	339.0	329.2	319.2	309.1	298.8	288.4	277.8	268.0	257.8
	kW	23.7	25.3	27.1	28.5	30.0	31.5	33.2	34.9	36.7	38.1	39.6
40	TC	390.7	379.8	368.5	358.0	347.4	336.7	325.7	314.5	303.1	292.7	281.8
	kW	25.2	26.8	28.5	29.9	31.4	32.9	34.5	36.2	38.0	39.4	41.0
45	TC	421.2	409.6	397.6	386.5	373.5	363.7	352.1	340.2	328.1	317.0	305.4
	kW	25.2	26.8	28.5	29.9	31.4	32.9	34.5	36.2	38.0	39.4	41.0
50	TC	452.0	439.6	426.8	414.8	402.6	390.3	377.9	365.3	352.2	340.3	327.9
	kW	26.1	27.6	29.4	30.7	32.2	33.7	35.3	36.9	38.7	40.1	41.6

## 38APD040 CONDENSING UNIT RATINGS, 60 Hz ENGLISH

SST (F)*		CONDENSER ENTERING-AIR TEMPERATURE (F)										
		70	80	85	90	95	100	105	110	115	120	125
30	TC	411.2	397.9	384.0	371.1	358.4	345.3	331.9	318.0	304.1	291.5	278.2
	kW	27.1	29.1	31.3	33.1	35.0	37.0	39.0	41.1	43.3	45.1	47.1
35	TC	451.9	437.5	422.8	408.8	394.9	380.7	366.4	351.6	336.8	323.0	308.7
	kW	27.6	29.7	31.9	33.7	35.6	37.7	39.7	41.9	44.1	45.9	47.9
40	TC	494.0	478.6	462.8	447.5	432.2	417.3	401.5	385.9	369.6	354.8	339.3
	kW	28.8	30.8	33.1	34.9	36.5	38.9	41.0	43.2	45.4	47.3	49.4
45	TC	538.1	521.2	503.7	486.9	470.9	453.8	437.0	420.1	401.4	385.6	368.7
	kW	28.8	30.8	33.1	34.9	36.5	38.9	41.0	43.2	45.4	47.3	49.4
50	TC	582.3	563.9	544.3	527.5	509.4	491.1	471.6	453.6	434.5	416.7	398.3
	kW	29.4	31.5	33.7	35.6	37.6	39.6	41.7	43.9	46.1	48.0	50.1

### LEGEND

- kW** — Compressor Power
- SST** — Saturated Suction Temperature Entering Condensing Unit
- TC** — Gross Cooling Capacity (1000 Btuh)

### NOTES:

1. Ratings are based on 15 F superheat and use of R-410A refrigerant.
2. Ratings include suction line losses due to an accumulator.
3. Refer to Commercial Split Builder program for more detailed information.

\* 38AP units are not designed for refrigeration duty. Unit operational range should be reviewed to ensure that operation at full and part load conditions with saturated suction temperatures at or below 30 F are avoided. Operation below 30 F SST may result in ice build-up on evaporator coil, resulting in liquid flood-back and possible compressor failure.

### 38APS040 CONDENSING UNIT RATINGS, 60 Hz ENGLISH

SST (F)*		CONDENSER ENTERING-AIR TEMPERATURE (F)										
		70	80	85	90	95	100	105	110	115	120	125
30	TC	416.3	403.6	390.5	378.2	365.7	353.1	340.3	327.4	314.1	301.9	289.1
	kW	27.3	29.2	31.3	33.0	34.7	36.5	38.4	40.4	42.5	44.2	46.0
35	TC	456.7	442.8	428.5	414.9	401.3	387.5	373.5	359.3	344.8	331.4	317.5
	kW	28.2	30.1	32.1	33.8	35.5	37.4	39.3	41.3	43.4	45.0	46.9
40	TC	498.8	483.7	468.2	453.4	438.5	423.4	408.1	392.6	377.5	362.5	347.3
	kW	29.1	30.9	33.0	34.7	36.4	38.3	40.2	42.2	44.3	45.9	47.8
45	TC	543.2	526.6	510.2	493.3	477.0	460.5	443.7	427.7	410.6	394.2	377.7
	kW	30.1	31.9	34.0	35.7	37.4	39.2	41.1	43.1	45.2	46.9	48.7
50	TC	589.2	571.2	553.5	535.0	517.1	499.0	481.9	463.6	445.1	427.4	409.4
	kW	31.1	33.0	35.1	36.7	38.4	40.2	42.2	44.2	46.2	47.9	49.7

### 38APD050 CONDENSING UNIT RATINGS, 60 Hz ENGLISH

SST (F)*		CONDENSER ENTERING-AIR TEMPERATURE (F)										
		70	80	85	90	95	100	105	110	115	120	125
30	TC	526.4	509.8	492.9	476.6	460.3	444.3	426.8	410.3	393.4	377.2	360.6
	kW	38.1	40.6	43.4	45.7	48.0	50.5	53.1	55.7	58.5	60.7	63.2
35	TC	578.9	560.6	541.3	524.3	506.7	488.5	469.7	450.8	432.5	414.8	396.5
	kW	39.1	41.6	44.4	46.7	49.1	51.6	54.1	56.8	59.5	61.8	64.4
40	TC	632.1	612.3	591.1	572.6	553.4	534.0	514.4	493.3	472.0	453.7	433.8
	kW	41.1	43.6	46.4	48.7	50.1	53.6	56.2	58.9	61.7	64.0	66.5
45	TC	686.6	665.0	642.1	622.2	600.2	580.1	556.8	534.9	513.9	492.5	471.0
	kW	41.1	43.6	46.4	48.7	50.1	53.6	56.2	58.9	61.7	64.0	66.5
50	TC	740.3	717.1	693.4	670.7	648.0	624.2	600.4	578.3	553.9	531.1	507.9
	kW	42.2	44.7	47.5	49.8	52.2	54.7	57.3	60.0	62.7	65.0	67.6

### 38APS050 CONDENSING UNIT RATINGS, 60 Hz ENGLISH

SST (F)*		CONDENSER ENTERING-AIR TEMPERATURE (F)										
		70	80	85	90	95	100	105	110	115	120	125
30	TC	503.7	486.6	471.0	453.0	435.0	417.0	399.0	381.2	371.3	349.9	332.8
	kW	59.7	61.9	40.3	42.5	44.7	46.9	49.1	51.4	54.1	40.3	42.5
35	TC	551.1	534.3	516.6	500.6	484.4	469.0	451.0	433.9	415.9	400.3	383.6
	kW	36.4	38.7	41.3	43.4	45.6	47.9	50.3	52.8	55.3	57.4	59.8
40	TC	602.4	584.3	565.4	548.0	530.1	512.1	495.3	476.6	455.5	439.4	421.3
	kW	37.3	39.7	42.3	44.4	46.6	48.8	51.3	53.8	56.3	58.4	60.8
45	TC	656.0	636.0	614.8	596.9	577.5	556.4	536.3	515.7	496.6	476.6	456.7
	kW	38.9	41.2	43.2	45.4	49.2	49.8	52.2	54.6	57.2	59.3	61.5
50	TC	710.1	688.0	665.3	644.2	623.1	599.6	577.5	556.3	533.4	511.8	489.8
	kW	39.5	41.8	44.3	46.4	48.5	50.8	53.1	55.6	58.1	60.1	62.4

### 38APD060 CONDENSING UNIT RATINGS, 60 Hz ENGLISH

SST (F)*		CONDENSER ENTERING-AIR TEMPERATURE (F)										
		70	80	85	90	95	100	105	110	115	120	125
30	TC	607.4	589.8	570.0	555.1	536.5	520.8	503.6	486.0	462.4	448.6	431.0
	kW	42.4	45.2	48.3	50.9	53.4	56.0	58.9	62.0	65.2	67.6	70.4
35	TC	653.4	636.1	609.0	605.5	591.5	573.3	546.6	532.6	511.7	498.2	481.0
	kW	43.6	46.5	49.5	52.1	54.7	57.6	60.3	63.2	66.4	68.9	71.7
40	TC	701.2	684.4	649.2	660.0	645.0	623.4	602.6	581.2	559.3	550.1	533.3
	kW	46.4	49.2	52.2	54.9	57.6	60.4	63.2	66.1	69.2	71.8	74.6
45	TC	760.6	742.3	705.5	712.8	700.1	679.5	648.7	631.8	606.0	596.1	577.8
	kW	46.4	49.2	52.2	54.9	57.6	60.4	63.2	66.1	69.2	71.8	74.6
50	TC	835.2	813.2	776.2	779.4	754.4	728.7	704.3	678.9	654.7	637.2	615.3
	kW	48.1	50.9	53.9	56.7	59.2	61.9	64.7	67.7	70.8	73.3	76.1

#### LEGEND

- kW** — Compressor Power
- SST** — Saturated Suction Temperature Entering Condensing Unit
- TC** — Gross Cooling Capacity (1000 Btuh)

\* 38AP units are not designed for refrigeration duty. Unit operational range should be reviewed to ensure that operation at full and part load conditions with saturated suction temperatures at or below 30 F are avoided. Operation below 30 F SST may result in ice build-up on evaporator coil, resulting in liquid flood-back and possible compressor failure.

#### NOTES:

1. Ratings are based on 15 F superheat and use of R-410A refrigerant.
2. Ratings include suction line losses due to an accumulator.
3. Refer to Commercial Split Builder program for more detailed information.

# Performance data (cont)



## 38APS065 CONDENSING UNIT RATINGS, 60 Hz ENGLISH

SST (F)*		CONDENSER ENTERING-AIR TEMPERATURE (F)										
		70	80	85	90	95	100	105	110	115	120	125
30	TC	622.1	602.1	582.0	561.9	542.0	521.7	502.2	481.9	461.5	441.7	421.6
	kW	44.3	47.2	50.3	52.8	55.5	58.3	61.1	64.1	67.3	69.8	72.6
35	TC	683.9	662.0	639.6	618.0	596.5	574.7	552.7	530.4	507.9	486.5	464.6
	kW	45.7	48.6	51.7	54.2	56.9	59.7	62.6	65.6	68.7	71.2	74.1
40	TC	748.5	724.6	700.7	676.9	652.8	628.7	605.8	581.0	557.4	533.5	509.6
	kW	47.2	50.1	53.2	55.7	58.4	61.1	64.0	67.1	70.2	72.7	75.5
45	TC	818.8	792.3	765.8	738.0	714.6	685.8	660.6	634.8	604.8	580.2	553.6
	kW	48.4	51.3	54.8	57.3	58.5	62.7	65.6	68.6	71.7	74.2	77.1
50	TC	882.2	854.9	826.1	801.4	771.8	747.7	719.4	691.9	661.9	636.6	609.3
	kW	50.6	53.4	56.5	59.0	61.7	64.5	67.3	70.3	73.4	75.9	78.8

## 38APD070 CONDENSING UNIT RATINGS, 60 Hz ENGLISH

SST (F)*		CONDENSER ENTERING-AIR TEMPERATURE (F)										
		70	80	85	90	95	100	105	110	115	120	125
30	TC	698.4	676.5	653.9	632.7	611.3	589.6	567.5	545.3	522.5	501.5	479.6
	kW	50.5	53.9	57.5	60.5	63.6	66.9	70.3	73.8	77.4	80.5	83.8
35	TC	767.9	744.3	719.9	697.0	673.9	650.4	626.8	602.7	578.0	555.3	531.7
	kW	51.9	55.3	59.0	62.0	65.2	68.5	72.0	75.5	79.2	82.2	85.6
40	TC	840.5	815.0	788.7	763.9	739.0	713.7	688.1	662.0	635.5	610.9	585.4
	kW	54.9	58.3	62.1	65.2	67.6	71.8	75.3	78.9	82.7	85.7	89.2
45	TC	915.5	887.9	859.4	832.7	807.0	778.5	750.8	722.6	693.9	667.4	639.9
	kW	54.9	58.3	62.1	65.2	67.6	71.8	75.3	78.9	82.7	85.7	89.2
50	TC	992.3	962.6	931.7	903.1	873.9	844.4	814.6	784.1	753.1	724.6	694.8
	kW	56.6	60.1	63.8	66.9	70.1	73.5	77.0	80.6	84.4	87.5	90.9

## 38APD080 CONDENSING UNIT RATINGS, 60 Hz ENGLISH

SST (F)*		CONDENSER ENTERING-AIR TEMPERATURE (F)										
		70	80	85	90	95	100	105	110	115	120	125
30	TC	824.8	800.2	775.3	750.3	726.6	702.5	677.3	652.6	626.9	603.1	578.5
	kW	57.1	60.9	65.1	68.5	72.1	75.9	79.8	83.8	88.1	91.5	95.3
35	TC	902.7	876.5	848.6	823.9	794.7	779.3	744.6	725.6	686.9	667.4	641.3
	kW	58.6	62.5	66.7	70.1	73.6	77.4	81.3	85.2	89.6	92.9	96.7
40	TC	985.7	957.2	924.6	903.7	877.6	836.6	820.3	778.4	761.5	729.3	700.8
	kW	62.0	65.8	69.8	73.4	77.1	80.7	84.5	88.6	92.7	96.2	100.0
45	TC	1056.5	1026.9	984.8	974.7	936.0	917.5	885.5	854.6	805.0	789.7	760.1
	kW	62.0	65.8	69.8	73.4	77.1	80.7	84.5	88.6	92.7	96.2	100.0
50	TC	1142.4	1109.6	1068.4	1046.7	1018.3	981.5	949.4	907.8	878.4	847.6	814.9
	kW	63.9	67.7	71.6	75.3	79.0	82.5	86.4	90.2	94.3	97.8	101.6

## 38APD090 CONDENSING UNIT RATINGS, 60 Hz ENGLISH

SST (F)*		CONDENSER ENTERING-AIR TEMPERATURE (F)										
		70	80	85	90	95	100	105	110	115	120	125
30	TC	918.4	891.5	862.2	836.4	817.8	782.0	755.0	735.1	699.9	676.5	649.7
	kW	62.1	66.5	71.4	75.4	79.4	83.8	88.3	92.8	97.9	101.8	106.2
35	TC	1011.8	981.5	945.3	925.6	888.2	867.5	826.8	805.8	762.7	739.0	708.7
	kW	63.7	68.0	72.8	76.7	80.9	85.2	89.7	94.0	99.1	102.9	107.3
40	TC	1099.9	1067.2	1030.0	1005.9	974.9	930.2	908.9	863.6	842.0	805.8	773.1
	kW	66.9	71.2	75.8	79.8	83.9	88.2	92.5	97.0	101.7	105.6	109.9
45	TC	1173.6	1140.2	1092.4	1078.8	1048.3	1016.3	973.9	936.6	900.1	872.9	839.5
	kW	66.9	71.2	75.8	79.8	83.9	88.2	92.5	97.0	101.7	105.6	109.9
50	TC	1270.4	1232.1	1191.3	1153.5	1122.4	1086.0	1035.8	997.6	966.9	926.0	887.7
	kW	68.8	73.1	77.6	81.6	85.8	89.9	94.0	98.5	103.3	107.1	111.3

### LEGEND

- kW — Compressor Power
- SST — Saturated Suction Temperature Entering Condensing Unit
- TC — Gross Cooling Capacity (1000 Btuh)

### NOTES:

1. Ratings are based on 15 F superheat and use of R-410A refrigerant.
2. Ratings include suction line losses due to an accumulator.
3. Refer to Commercial Split Builder program for more detailed information.

\* 38AP units are not designed for refrigeration duty. Unit operational range should be reviewed to ensure that operation at full and part load conditions with saturated suction temperatures at or below 30 F are avoided. Operation below 30 F SST may result in ice build-up on evaporator coil, resulting in liquid flood-back and possible compressor failure.



### 38APD100 CONDENSING UNIT RATINGS, 60 Hz ENGLISH

SST (F)*		CONDENSER ENTERING-AIR TEMPERATURE (F)										
		70	80	85	90	95	100	105	110	115	120	125
30	TC	1001.0	971.8	941.7	913.3	884.5	855.6	826.2	796.3	766.2	737.9	708.6
	kW	69.6	74.3	79.5	83.7	88.1	92.7	97.5	102.5	107.7	111.8	116.5
35	TC	1101.5	1069.6	1036.7	1005.8	974.6	942.9	910.9	878.5	845.4	814.6	782.7
	kW	71.8	76.5	81.7	85.9	90.2	94.8	99.6	104.6	109.8	114.0	118.7
40	TC	1207.6	1172.8	1137.0	1103.4	1069.3	1034.9	1000.1	964.6	928.5	895.1	860.3
	kW	76.4	81.0	86.2	90.4	94.7	99.3	104.1	109.0	114.3	118.4	123.1
45	TC	1315.3	1277.8	1241.6	1204.9	1152.0	1130.4	1092.3	1053.6	1014.0	977.7	940.2
	kW	76.4	81.0	86.2	90.4	94.7	99.3	104.1	109.0	114.3	118.4	123.1
50	TC	1433.5	1392.2	1349.3	1309.4	1269.0	1228.0	1186.4	1144.2	1101.0	1061.4	1020.0
	kW	78.9	83.6	88.7	92.8	97.2	101.7	106.4	111.4	116.6	120.7	125.3

### 38APD115 CONDENSING UNIT RATINGS, 60 Hz ENGLISH

SST (F)*		CONDENSER ENTERING-AIR TEMPERATURE (F)										
		70	80	85	90	95	100	105	110	115	120	125
30	TC	1137.3	1102.9	1067.8	1034.0	1000.1	965.8	931.3	896.4	861.2	827.6	793.2
	kW	79.4	84.9	91.0	95.9	101.0	106.3	111.9	117.8	123.9	128.7	134.2
35	TC	1253.3	1215.7	1177.3	1140.5	1103.5	1066.1	1028.4	990.3	951.8	915.2	877.6
	kW	81.7	87.2	93.2	98.1	103.2	108.6	114.2	120.0	126.1	131.0	136.4
40	TC	1375.5	1334.4	1292.4	1252.4	1212.0	1171.2	1130.1	1088.4	1046.2	1006.3	965.3
	kW	86.4	91.9	97.9	102.8	108.6	113.2	118.7	124.5	130.6	135.4	140.9
45	TC	1503.9	1458.9	1412.1	1368.2	1327.2	1279.6	1234.6	1189.1	1142.7	1099.2	1054.3
	kW	86.4	91.9	97.9	102.8	108.6	113.2	118.7	124.5	130.6	135.4	140.9
50	TC	1633.7	1584.6	1534.2	1486.4	1438.1	1389.5	1340.2	1290.4	1239.5	1192.0	1142.9
	kW	89.0	94.4	100.4	105.2	110.3	115.6	121.1	126.9	132.9	137.7	143.2

### 38APD130 CONDENSING UNIT RATINGS, 60 Hz ENGLISH

SST (F)*		CONDENSER ENTERING-AIR TEMPERATURE (F)										
		70	80	85	90	95	100	105	110	115	120	125
30	TC	1296.8	1258.6	1218.2	1183.0	1145.2	1107.6	1068.3	1029.3	990.1	953.3	915.1
	kW	91.6	97.5	104.1	109.4	115.0	120.8	126.8	133.1	139.7	145.0	150.9
35	TC	1428.8	1386.9	1344.0	1302.9	1262.0	1220.8	1177.7	1135.4	1092.7	1051.8	1009.9
	kW	94.5	100.4	107.0	112.3	117.8	123.6	129.6	136.0	142.5	147.8	153.8
40	TC	1566.0	1520.3	1474.2	1427.7	1384.4	1337.8	1293.7	1245.4	1199.5	1154.7	1109.0
	kW	100.5	106.4	113.0	118.3	124.4	129.5	135.6	141.9	148.5	153.7	159.6
45	TC	1706.2	1657.1	1609.3	1561.2	1510.0	1459.8	1407.3	1358.6	1321.0	1264.9	1215.9
	kW	100.5	106.4	113.0	118.3	124.4	129.5	135.6	141.9	148.5	153.7	159.6
50	TC	1857.5	1804.1	1740.0	1704.8	1653.7	1584.1	1545.6	1472.5	1432.3	1376.7	1323.3
	kW	104.1	109.9	116.3	121.8	127.3	132.7	139.1	145.0	151.6	156.9	162.7

#### LEGEND

**kW** — Compressor Power  
**SST** — Saturated Suction Temperature Entering Condensing Unit  
**TC** — Gross Cooling Capacity (1000 Btuh)

#### NOTES:

1. Ratings are based on 15 F superheat and use of R-410A refrigerant.
2. Ratings include suction line losses due to an accumulator.
3. Refer to Commercial Split Builder program for more detailed information.

\* 38AP units are not designed for refrigeration duty. Unit operational range should be reviewed to ensure that operation at full and part load conditions with saturated suction temperatures at or below 30 F are avoided. Operation below 30 F SST may result in ice build-up on evaporator coil, resulting in liquid flood-back and possible compressor failure.

# Performance data (cont)



## 38APD025 CONDENSING UNIT CIRCUIT RATINGS, 60 Hz ENGLISH CIRCUIT A

SST (F)*		CONDENSER ENTERING-AIR TEMPERATURE (F)										
		70	80	85	90	95	100	105	110	115	120	125
30	TC	125.0	120.9	116.6	112.7	108.7	104.6	100.5	96.3	92.0	88.1	84.0
	kW	8.6	9.2	9.8	10.3	10.8	11.4	12.0	12.6	13.2	13.7	14.3
35	TC	137.8	133.4	128.8	124.6	120.3	115.9	111.5	107.0	102.4	98.2	93.8
	kW	8.7	9.3	9.9	10.5	11.0	11.6	12.2	12.8	13.4	13.9	14.5
40	TC	151.0	146.2	141.3	136.7	132.1	127.4	122.7	117.8	112.8	108.3	103.6
	kW	8.9	9.5	10.1	10.6	11.2	11.8	12.3	13.0	13.6	14.1	14.7
45	TC	164.1	159.0	153.7	148.8	143.8	138.7	133.5	128.3	123.0	118.1	112.9
	kW	9.0	9.6	10.2	10.8	11.4	11.9	12.5	13.1	13.8	14.3	14.9
50	TC	176.9	171.3	165.6	160.2	154.8	149.3	143.7	138.1	132.3	127.0	121.4
	kW	9.2	9.8	10.4	11.0	11.5	12.1	12.7	13.3	13.9	14.5	15.0

### CIRCUIT B

SST (F)*		CONDENSER ENTERING-AIR TEMPERATURE (F)										
		70	80	85	90	95	100	105	110	115	120	125
30	TC	125.0	120.9	116.6	112.7	108.7	104.6	100.5	96.3	92.0	88.1	84.0
	kW	8.6	9.2	9.8	10.3	10.8	11.4	12.0	12.6	13.2	13.7	14.3
35	TC	137.8	133.4	128.8	124.6	120.3	115.9	111.5	107.0	102.4	98.2	93.8
	kW	8.7	9.3	9.9	10.5	11.0	11.6	12.2	12.8	13.4	13.9	14.5
40	TC	151.0	146.2	141.3	136.7	132.1	127.4	122.7	117.8	112.8	108.3	103.6
	kW	8.9	9.5	10.1	10.6	11.2	11.8	12.3	13.0	13.6	14.1	14.7
45	TC	164.1	159.0	153.7	148.8	143.8	138.7	133.5	128.3	123.0	118.1	112.9
	kW	9.0	9.6	10.2	10.8	11.4	11.9	12.5	13.1	13.8	14.3	14.9
50	TC	176.9	171.3	165.6	160.2	154.8	149.3	143.7	138.1	132.3	127.0	121.4
	kW	9.2	9.8	10.4	11.0	11.5	12.1	12.7	13.3	13.9	14.5	15.0

## 38APD027 CONDENSING UNIT CIRCUIT RATINGS, 60 Hz ENGLISH CIRCUIT A

SST (F)*		CONDENSER ENTERING-AIR TEMPERATURE (F)										
		70	80	85	90	95	100	105	110	115	120	125
30	TC	141.7	137.5	133.2	129.2	125.1	121.0	116.8	112.6	108.2	104.3	100.1
	kW	9.6	10.2	10.9	11.5	12.1	12.7	13.4	14.0	14.8	15.3	16.0
35	TC	155.5	151.0	146.2	141.9	137.5	132.9	128.4	123.7	119.0	114.7	110.1
	kW	9.8	10.5	11.2	11.7	12.3	13.0	13.6	14.3	15.0	15.6	16.2
40	TC	169.5	164.6	159.5	154.7	149.9	145.1	140.1	135.1	130.0	125.3	120.3
	kW	10.1	10.7	11.5	12.0	12.6	13.2	13.9	14.5	15.3	15.8	16.4
45	TC	183.5	178.1	172.6	167.5	159.3	156.9	151.6	146.1	140.6	135.5	130.1
	kW	10.4	11.1	11.8	12.3	12.9	13.5	14.1	14.8	15.5	16.1	16.7
50	TC	197.3	191.5	185.6	180.0	174.3	168.5	162.7	156.8	150.8	145.2	139.4
	kW	10.8	11.4	12.1	12.6	13.2	13.8	14.4	15.1	15.8	16.3	16.9

### CIRCUIT B

SST (F)*		CONDENSER ENTERING-AIR TEMPERATURE (F)										
		70	80	85	90	95	100	105	110	115	120	125
30	TC	140.9	136.7	132.4	128.3	124.2	120.0	115.8	111.6	107.2	103.2	99.0
	kW	9.6	10.2	10.9	11.5	12.1	12.7	13.3	14.0	14.7	15.3	15.9
35	TC	154.2	149.6	144.9	140.4	136.0	131.4	126.8	122.1	117.4	113.0	108.4
	kW	9.8	10.5	11.2	11.7	12.3	12.9	13.6	14.2	14.9	15.5	16.1
40	TC	167.5	162.5	157.3	152.6	147.7	142.8	137.8	132.7	127.5	122.8	117.8
	kW	10.1	10.7	11.4	12.0	12.6	13.2	13.8	14.5	15.2	15.8	16.4
45	TC	180.8	175.3	169.8	164.5	159.3	153.8	148.4	142.9	137.3	132.0	126.6
	kW	10.4	11.0	11.7	12.3	12.9	13.5	14.1	14.8	15.5	16.0	16.7
50	TC	193.9	188.0	182.0	176.2	170.4	164.6	158.7	152.7	146.6	140.9	135.0
	kW	10.8	11.4	12.1	12.6	13.2	13.8	14.4	15.1	15.8	16.3	16.9

#### LEGEND

- kW** — Compressor Power
- SST** — Saturated Suction Temperature Entering Condensing Unit
- TC** — Gross Cooling Capacity (1000 Btuh)

\* 38AP units are not designed for refrigeration duty. Unit operational range should be reviewed to ensure that operation at full and part load conditions with saturated suction temperatures at or below 30 F are avoided. Operation below 30 F SST may result in ice build-up on evaporator coil, resulting in liquid flood-back and possible compressor failure.

#### NOTES:

1. Ratings are based on 15 F superheat and use of R-410A refrigerant.
2. Ratings include suction line losses due to an accumulator.
3. Refer to Commercial Split Builder program for more detailed information.



**38APD030 CONDENSING UNIT CIRCUIT RATINGS, 60 Hz ENGLISH**  
**CIRCUIT A**

SST (F)*		CONDENSER ENTERING-AIR TEMPERATURE (F)										
		70	80	85	90	95	100	105	110	115	120	125
30	TC	164.3	159.5	154.7	150.1	145.5	140.8	136.2	131.3	126.4	121.9	117.2
	kW	11.5	12.3	13.1	13.8	14.6	15.4	16.2	17.0	17.9	18.6	19.4
35	TC	179.7	174.6	169.3	164.5	159.5	154.5	149.4	144.2	138.9	134.0	128.9
	kW	11.8	12.6	13.5	14.2	14.9	15.7	16.5	17.3	18.2	18.9	19.7
40	TC	195.0	189.6	184.0	178.8	173.6	168.2	162.8	157.2	151.5	146.4	141.0
	kW	12.1	12.9	13.8	14.5	15.2	16.0	16.8	17.7	18.5	19.2	20.0
45	TC	210.1	204.4	198.4	192.9	186.7	181.7	175.9	170.0	164.0	158.6	152.8
	kW	12.5	13.3	14.2	14.9	15.6	16.4	17.2	18.0	18.9	19.6	20.3
50	TC	225.3	219.2	212.8	206.9	200.9	194.9	188.7	182.5	176.0	170.2	164.0
	kW	13.0	13.7	14.6	15.3	16.0	16.7	17.5	18.3	19.2	19.9	20.7

**CIRCUIT B**

SST (F)*		CONDENSER ENTERING-AIR TEMPERATURE (F)										
		70	80	85	90	95	100	105	110	115	120	125
30	TC	164.5	159.8	154.9	150.3	145.8	141.0	136.3	131.5	126.6	122.0	117.3
	kW	11.6	12.4	13.3	14.0	14.8	15.5	16.3	17.2	18.1	18.8	19.6
35	TC	180.1	175.0	169.7	164.7	159.7	154.7	149.5	144.3	138.9	134.0	128.9
	kW	12.0	12.8	13.6	14.4	15.1	15.9	16.7	17.5	18.4	19.1	19.9
40	TC	195.7	190.2	184.5	179.2	173.9	168.5	162.9	157.3	151.5	146.3	140.8
	kW	12.3	13.1	14.0	14.7	15.4	16.2	17.0	17.9	18.8	19.5	20.3
45	TC	211.1	205.3	199.2	193.5	186.8	182.1	176.2	170.2	164.0	158.5	152.6
	kW	12.7	13.5	14.4	15.1	15.8	16.6	17.4	18.2	19.1	19.8	20.6
50	TC	226.7	220.4	213.9	207.9	201.7	195.5	189.2	182.8	176.2	170.2	163.9
	kW	13.1	13.9	14.8	15.5	16.2	17.0	17.8	18.6	19.5	20.2	21.0

**38APD040 CONDENSING UNIT CIRCUIT RATINGS, 60 Hz ENGLISH**  
**CIRCUIT A**

SST (F)*		CONDENSER ENTERING-AIR TEMPERATURE (F)										
		70	80	85	90	95	100	105	110	115	120	125
30	TC	220.1	212.7	205.0	197.8	190.9	183.6	176.2	168.3	160.6	153.7	146.3
	kW	15.0	16.1	17.2	18.1	19.1	20.1	21.2	22.2	23.3	24.3	25.3
35	TC	242.1	234.2	226.1	218.3	210.7	202.8	194.9	186.7	178.6	170.9	163.0
	kW	15.3	16.4	17.5	18.5	19.5	20.5	21.6	22.7	23.8	24.8	25.9
40	TC	264.9	256.4	247.7	239.3	230.9	222.7	214.1	205.4	196.5	188.3	179.8
	kW	15.6	16.7	17.9	18.9	19.9	20.9	22.0	23.2	24.3	25.3	26.4
45	TC	288.6	279.4	269.8	260.7	252.0	242.7	233.3	224.1	214.1	205.4	196.1
	kW	16.0	17.1	18.2	19.2	20.1	21.3	22.4	23.6	24.7	25.7	26.8
50	TC	312.6	302.6	292.0	282.8	272.6	262.7	252.4	242.3	231.9	222.2	212.1
	kW	16.4	17.5	18.6	19.6	20.7	21.7	22.8	24.0	25.2	26.2	27.3

**CIRCUIT B**

SST (F)*		CONDENSER ENTERING-AIR TEMPERATURE (F)										
		70	80	85	90	95	100	105	110	115	120	125
30	TC	191.1	185.2	179.0	173.3	167.6	161.7	155.8	149.7	143.5	137.8	131.9
	kW	12.1	13.1	14.1	15.0	15.9	16.9	17.9	18.9	20.0	20.8	21.8
35	TC	209.7	203.3	196.7	190.5	184.3	177.9	171.5	164.9	158.2	152.1	145.7
	kW	12.3	13.3	14.4	15.2	16.2	17.1	18.1	19.2	20.2	21.1	22.1
40	TC	229.1	222.1	215.0	208.2	201.2	194.6	187.4	180.4	173.1	166.4	159.5
	kW	12.5	13.5	14.6	15.5	16.4	17.3	18.3	19.4	20.5	21.4	22.3
45	TC	249.5	241.8	233.9	226.2	218.9	211.0	203.6	196.0	187.3	180.2	172.6
	kW	12.8	13.8	14.8	15.7	16.4	17.6	18.6	19.6	20.7	21.6	22.6
50	TC	269.6	261.3	252.3	244.8	236.8	228.4	219.2	211.2	202.6	194.5	186.2
	kW	13.0	14.0	15.1	16.0	16.9	17.8	18.8	19.9	21.0	21.8	22.8

**LEGEND**

- kW** — Compressor Power
- SST** — Saturated Suction Temperature Entering Condensing Unit
- TC** — Gross Cooling Capacity (1000 Btuh)

\* 38AP units are not designed for refrigeration duty. Unit operational range should be reviewed to ensure that operation at full and part load conditions with saturated suction temperatures at or below 30 F are avoided. Operation below 30 F SST may result in ice build-up on evaporator coil, resulting in liquid flood-back and possible compressor failure.

**NOTES:**

1. Ratings are based on 15 F superheat and use of R-410A refrigerant.
2. Ratings include suction line losses due to an accumulator.
3. Refer to Commercial Split Builder program for more detailed information.

# Performance data (cont)



## 38APD050 CONDENSING UNIT CIRCUIT RATINGS, 60 Hz ENGLISH CIRCUIT A

SST (F)*		CONDENSER ENTERING-AIR TEMPERATURE (F)										
		70	80	85	90	95	100	105	110	115	120	125
30	TC	248.7	240.5	232.3	224.1	216.1	208.3	199.7	191.7	183.2	175.3	167.1
	kW	17.7	18.9	20.2	21.4	22.5	23.7	25.0	26.3	27.5	28.7	29.9
35	TC	274.0	265.1	255.8	247.4	238.8	230.1	220.7	211.6	203.0	194.2	185.3
	kW	18.0	19.2	20.6	21.7	22.9	24.1	25.4	26.7	28.0	29.2	30.4
40	TC	300.0	290.4	280.0	271.2	261.9	252.5	242.9	232.5	222.4	213.4	203.8
	kW	18.3	19.5	20.9	22.0	23.2	24.5	25.8	27.1	28.4	29.6	30.9
45	TC	326.5	316.1	305.2	295.4	285.0	275.1	264.1	253.5	243.3	233.0	222.7
	kW	18.5	19.8	21.2	22.4	23.0	24.8	26.1	27.4	28.8	30.0	31.3
50	TC	353.2	342.0	330.4	319.6	309.1	297.2	285.8	274.9	263.2	252.3	241.1
	kW	18.9	20.1	21.5	22.7	23.9	25.1	26.4	27.8	29.2	30.3	31.6

### CIRCUIT B

SST (F)*		CONDENSER ENTERING-AIR TEMPERATURE (F)										
		70	80	85	90	95	100	105	110	115	120	125
30	TC	277.7	269.3	260.6	252.5	244.2	236.0	227.1	218.5	210.3	201.9	193.5
	kW	20.4	21.7	23.2	24.3	25.5	26.8	28.1	29.5	30.9	32.0	33.3
35	TC	304.9	295.5	285.5	276.9	267.8	258.4	248.9	239.3	229.5	220.6	211.2
	kW	21.1	22.4	23.8	25.0	26.2	27.4	28.7	30.1	31.5	32.7	34.0
40	TC	332.1	321.9	311.1	301.4	291.5	281.4	271.6	260.8	249.6	240.2	230.0
	kW	21.8	23.1	24.5	25.6	26.8	28.1	29.4	30.8	32.2	33.3	34.6
45	TC	360.1	348.9	336.9	326.8	315.2	304.9	292.7	281.4	270.6	259.5	248.3
	kW	22.5	23.8	25.2	26.4	27.1	28.8	30.1	31.5	32.9	34.0	35.3
50	TC	387.1	375.1	363.0	351.1	338.9	327.0	314.6	303.4	290.6	278.8	266.8
	kW	23.3	24.6	26.0	27.1	28.3	29.5	30.8	32.2	33.6	34.7	36.0

## 38APD060 CONDENSING UNIT CIRCUIT RATINGS, 60 Hz ENGLISH CIRCUIT A

SST (F)*		CONDENSER ENTERING-AIR TEMPERATURE (F)										
		70	80	85	90	95	100	105	110	115	120	125
30	TC	279.8	271.7	263.2	254.9	248.6	240.2	232.4	224.3	214.1	207.6	199.5
	kW	18.7	19.9	21.4	22.5	23.6	24.8	26.1	27.5	28.9	30.0	31.2
35	TC	305.4	296.8	287.3	279.2	272.5	264.1	251.3	245.4	236.5	227.9	219.3
	kW	19.3	20.5	21.9	23.0	24.2	25.4	26.6	28.0	29.4	30.5	31.7
40	TC	327.4	318.9	305.8	303.9	296.6	286.7	277.2	267.4	257.4	251.0	242.5
	kW	19.9	21.1	22.4	23.6	24.7	25.9	27.2	28.5	29.8	30.9	32.1
45	TC	352.5	343.7	329.6	327.4	321.6	312.1	298.1	290.3	280.0	273.2	264.4
	kW	20.4	21.6	23.0	24.2	25.3	26.6	27.8	29.1	30.6	31.7	32.9
50	TC	392.7	381.1	366.6	362.7	343.5	337.3	321.5	313.8	298.4	288.5	276.9
	kW	21.2	22.4	23.8	25.0	26.0	27.3	28.5	29.8	31.2	32.3	33.5

### CIRCUIT B

SST (F)*		CONDENSER ENTERING-AIR TEMPERATURE (F)										
		70	80	85	90	95	100	105	110	115	120	125
30	TC	327.6	318.0	306.8	300.2	287.9	280.5	271.3	261.7	248.3	241.1	231.4
	kW	23.7	25.3	27.0	28.5	29.8	31.3	32.9	34.6	36.3	37.6	39.2
35	TC	347.9	339.3	321.6	326.4	319.0	309.2	295.3	287.2	275.1	270.3	261.7
	kW	24.4	26.0	27.6	29.1	30.6	32.2	33.7	35.3	37.0	38.5	40.0
40	TC	373.7	365.4	343.5	356.2	348.4	336.7	325.4	313.8	302.0	299.1	290.8
	kW	25.2	26.7	28.3	29.9	31.4	32.8	34.4	36.0	37.6	39.1	40.6
45	TC	408.1	398.6	375.9	385.4	378.6	367.3	350.5	341.6	326.0	322.8	313.4
	kW	26.0	27.5	29.2	30.8	32.2	33.8	35.3	36.9	38.7	40.1	41.7
50	TC	442.4	432.0	409.6	416.7	410.9	391.3	382.8	365.1	356.2	348.7	338.3
	kW	26.9	28.5	30.1	31.7	33.2	34.6	36.2	37.8	39.6	41.0	42.6

#### LEGEND

- kW** — Compressor Power
- SST** — Saturated Suction Temperature Entering Condensing Unit
- TC** — Gross Cooling Capacity (1000 Btuh)

\* 38AP units are not designed for refrigeration duty. Unit operational range should be reviewed to ensure that operation at full and part load conditions with saturated suction temperatures at or below 30 F are avoided. Operation below 30 F SST may result in ice build-up on evaporator coil, resulting in liquid flood-back and possible compressor failure.

#### NOTES:

1. Ratings are based on 15 F superheat and use of R-410A refrigerant.
2. Ratings include suction line losses due to an accumulator.
3. Refer to Commercial Split Builder program for more detailed information.

### 38APD070 CONDENSING UNIT CIRCUIT RATINGS, 60 Hz ENGLISH

#### CIRCUIT A

SST (F)*		CONDENSER ENTERING-AIR TEMPERATURE (F)										
		70	80	85	90	95	100	105	110	115	120	125
30	TC	326.5	317.0	307.2	297.9	288.7	279.2	269.5	260.0	250.0	240.9	231.3
	kW	23.6	25.2	27.0	28.4	29.9	31.5	33.1	34.8	36.6	38.0	39.6
35	TC	359.3	348.9	338.3	328.2	318.0	307.7	297.4	286.8	276.0	266.0	255.7
	kW	24.4	26.0	27.7	29.2	30.6	32.2	33.8	35.5	37.3	38.7	40.3
40	TC	393.9	382.6	371.0	360.0	348.9	337.8	326.4	314.9	303.2	292.3	281.0
	kW	25.1	26.7	28.5	29.9	31.4	32.9	34.6	36.3	38.1	39.5	41.1
45	TC	429.9	417.6	404.9	393.0	381.6	368.9	356.5	343.9	331.1	319.3	307.0
	kW	26.0	27.5	29.3	30.7	31.8	33.7	35.4	37.1	38.8	40.2	41.8
50	TC	467.1	453.7	439.8	427.0	413.9	400.6	387.2	373.5	359.6	346.7	333.4
	kW	26.8	28.4	30.2	31.6	33.0	34.6	36.2	37.9	39.6	41.0	42.6

#### CIRCUIT B

SST (F)*		CONDENSER ENTERING-AIR TEMPERATURE (F)										
		70	80	85	90	95	100	105	110	115	120	125
30	TC	371.9	359.5	346.7	334.8	322.7	310.4	298.0	285.3	272.5	260.6	248.2
	kW	26.9	28.6	30.5	32.1	33.7	35.5	37.2	39.0	40.9	42.5	44.2
35	TC	408.6	395.3	381.6	368.8	355.8	342.7	329.4	315.8	302.0	289.3	276.0
	kW	27.5	29.3	31.2	32.9	34.6	36.3	38.1	40.0	41.9	43.5	45.3
40	TC	446.6	432.4	417.7	403.9	390.0	375.9	361.7	347.1	332.3	318.6	304.4
	kW	28.2	30.0	32.0	33.6	35.4	37.2	39.0	40.9	42.9	44.5	46.4
45	TC	485.6	470.3	454.5	439.7	425.4	409.7	394.3	378.7	362.8	348.1	332.9
	kW	29.0	30.8	32.8	34.5	35.8	38.0	39.9	41.8	43.8	45.5	47.4
50	TC	525.2	508.8	491.9	476.1	460.0	443.8	427.4	410.6	393.6	377.8	361.5
	kW	29.8	31.6	33.7	35.3	37.1	38.9	40.8	42.8	44.8	46.5	48.3

### 38APD080 CONDENSING UNIT CIRCUIT RATINGS, 60 Hz ENGLISH

#### CIRCUIT A

SST (F)*		CONDENSER ENTERING-AIR TEMPERATURE (F)										
		70	80	85	90	95	100	105	110	115	120	125
30	TC	328.7	318.9	309.0	299.1	289.7	280.1	270.0	260.3	250.1	240.6	230.8
	kW	23.0	24.5	26.2	27.5	28.9	30.3	31.8	33.4	35.1	36.4	37.9
35	TC	360.0	349.6	338.4	328.6	316.7	311.0	296.8	289.5	273.7	266.1	255.6
	kW	23.7	25.2	26.9	28.2	29.6	31.0	32.5	34.1	35.8	37.1	38.5
40	TC	394.0	382.6	369.4	361.1	350.8	333.8	327.7	310.3	304.1	290.9	279.4
	kW	24.5	26.0	27.6	29.0	30.4	31.7	33.3	34.8	36.5	37.8	39.3
45	TC	422.4	410.6	394.4	390.7	371.0	367.6	354.7	342.2	321.5	315.8	303.9
	kW	25.3	26.8	28.3	29.7	31.2	32.6	34.1	35.6	37.2	38.6	40.1
50	TC	459.7	446.3	428.0	421.3	410.0	395.0	382.0	360.9	352.9	339.4	326.1
	kW	26.2	27.6	29.1	30.6	32.0	33.4	34.9	36.4	38.0	39.4	40.8

#### CIRCUIT B

SST (F)*		CONDENSER ENTERING-AIR TEMPERATURE (F)										
		70	80	85	90	95	100	105	110	115	120	125
30	TC	496.2	481.3	466.3	451.3	436.9	422.4	407.3	392.3	376.8	362.5	347.6
	kW	34.1	36.4	39.0	41.1	43.3	45.5	47.9	50.4	53.0	55.1	57.4
35	TC	542.6	526.9	510.2	495.3	478.0	468.3	447.8	436.1	413.2	401.3	385.6
	kW	34.9	37.2	39.8	41.9	44.1	46.4	48.8	51.1	53.8	55.9	58.2
40	TC	591.6	574.6	555.2	542.6	526.9	502.8	492.6	468.1	457.4	438.4	421.4
	kW	35.8	38.1	40.7	42.8	45.0	47.2	49.6	52.1	54.6	56.7	59.0
45	TC	634.1	616.3	590.4	584.1	565.0	549.9	530.8	512.4	483.5	474.0	456.2
	kW	36.7	39.0	41.5	43.6	45.9	48.1	50.5	52.9	55.5	57.6	59.9
50	TC	682.7	663.3	640.4	625.4	608.3	586.6	567.4	546.8	525.5	508.2	488.8
	kW	37.7	40.0	42.5	44.7	46.9	49.1	51.4	53.9	56.3	58.5	60.8

#### LEGEND

**kW** — Compressor Power  
**SST** — Saturated Suction Temperature Entering Condensing Unit  
**TC** — Gross Cooling Capacity (1000 Btuh)

#### NOTES:

1. Ratings are based on 15 F superheat and use of R-410A refrigerant.
2. Ratings include suction line losses due to an accumulator.
3. Refer to Commercial Split Builder program for more detailed information.

\* 38AP units are not designed for refrigeration duty. Unit operational range should be reviewed to ensure that operation at full and part load conditions with saturated suction temperatures at or below 30 F are avoided. Operation below 30 F SST may result in ice build-up on evaporator coil, resulting in liquid flood-back and possible compressor failure.

# Performance data (cont)



## 38APD090 CONDENSING UNIT CIRCUIT RATINGS, 60 Hz ENGLISH CIRCUIT A

SST (F)*		CONDENSER ENTERING-AIR TEMPERATURE (F)										
		70	80	85	90	95	100	105	110	115	120	125
30	TC	426.2	413.5	400.1	387.3	378.6	362.0	349.4	340.0	323.4	312.4	299.8
	kW	27.8	29.8	32.1	33.9	35.8	37.9	40.0	42.0	44.4	46.2	48.2
35	TC	468.2	454.0	436.8	428.0	410.5	400.8	382.2	371.8	351.4	340.7	326.5
	kW	28.4	30.4	32.6	34.4	36.4	38.4	40.4	42.5	44.8	46.6	48.6
40	TC	509.3	493.9	476.6	464.5	449.8	429.5	418.9	397.4	387.3	370.2	354.7
	kW	29.1	31.1	33.3	35.1	37.0	38.9	40.9	43.1	45.2	47.0	49.0
45	TC	542.5	526.5	504.1	495.8	483.3	468.0	443.9	433.0	409.6	398.5	382.5
	kW	29.8	31.8	33.9	35.7	37.6	39.6	41.5	43.6	45.7	47.5	49.5
50	TC	589.4	570.8	554.4	530.1	516.7	501.0	468.9	460.1	443.2	421.9	403.2
	kW	30.7	32.7	34.8	36.4	38.4	40.3	42.0	44.2	46.4	48.1	50.0

### CIRCUIT B

SST (F)*		CONDENSER ENTERING-AIR TEMPERATURE (F)										
		70	80	85	90	95	100	105	110	115	120	125
30	TC	492.2	478.0	462.0	449.2	439.1	420.0	405.6	395.1	376.4	364.2	349.9
	kW	34.4	36.7	39.3	41.5	43.6	46.0	48.4	50.8	53.5	55.6	57.9
35	TC	543.6	527.5	508.5	497.6	477.8	466.8	444.7	434.0	411.3	398.4	382.2
	kW	35.3	37.6	40.2	42.3	44.5	46.8	49.2	51.6	54.3	56.3	58.7
40	TC	590.6	573.3	553.5	541.4	525.0	500.7	490.0	466.2	454.6	435.6	418.4
	kW	36.2	38.5	41.1	43.2	45.4	47.7	50.0	52.6	55.1	57.2	59.5
45	TC	631.1	613.7	588.2	583.0	565.0	548.3	530.0	503.6	490.5	474.5	457.1
	kW	37.1	39.4	41.9	44.1	46.3	48.6	51.0	53.4	56.0	58.1	60.4
50	TC	681.0	661.3	637.0	623.4	605.7	584.9	566.9	537.6	523.7	504.1	484.5
	kW	38.1	40.4	42.8	45.1	47.3	49.6	52.0	54.3	56.9	59.0	61.3

## 38APD100 CONDENSING UNIT CIRCUIT RATINGS, 60 Hz ENGLISH CIRCUIT A

SST (F)*		CONDENSER ENTERING-AIR TEMPERATURE (F)										
		70	80	85	90	95	100	105	110	115	120	125
30	TC	506.8	492.1	476.8	462.4	447.9	433.3	418.4	403.3	388.0	373.7	358.9
	kW	35.0	37.3	39.9	42.0	44.2	46.5	48.9	51.4	54.0	56.1	58.5
35	TC	557.6	541.5	524.8	509.2	493.4	477.3	461.1	444.7	428.0	412.4	396.3
	kW	36.0	38.4	41.0	43.1	45.3	47.6	50.0	52.5	55.1	57.2	59.5
40	TC	611.0	593.4	575.3	558.2	541.0	523.6	506.0	488.0	469.7	452.8	435.2
	kW	37.2	39.5	42.1	44.2	46.4	48.7	51.1	53.6	56.2	58.3	60.6
45	TC	663.7	644.9	628.0	609.4	576.5	571.7	552.4	532.8	512.7	494.3	475.5
	kW	38.3	40.7	43.3	45.4	47.5	49.8	52.2	54.7	57.3	59.4	61.7
50	TC	724.9	704.0	682.2	662.0	641.5	620.8	599.7	578.3	556.4	536.3	515.4
	kW	39.6	42.0	44.5	46.6	48.8	51.0	53.4	55.9	58.5	60.5	62.9

### CIRCUIT B

SST (F)*		CONDENSER ENTERING-AIR TEMPERATURE (F)										
		70	80	85	90	95	100	105	110	115	120	125
30	TC	494.2	479.8	464.9	450.8	436.6	422.3	407.8	393.0	378.2	364.2	349.7
	kW	34.7	37.0	39.6	41.7	43.9	46.2	48.5	51.0	53.6	55.7	58.1
35	TC	543.9	528.2	511.9	496.7	481.2	465.6	449.8	433.8	417.4	402.2	386.5
	kW	35.7	38.1	40.7	42.8	44.9	47.2	49.6	52.1	54.7	56.8	59.1
40	TC	596.6	579.4	561.7	545.1	528.3	511.3	494.1	476.6	458.8	442.3	425.1
	kW	36.8	39.2	41.8	43.9	46.0	48.3	50.7	53.2	55.8	57.9	60.2
45	TC	651.6	632.9	613.6	595.5	575.5	558.7	539.9	520.8	501.3	483.3	464.6
	kW	38.0	40.3	42.9	45.0	47.2	49.5	51.8	54.3	56.9	59.0	61.3
50	TC	708.6	688.2	667.1	647.3	627.4	607.3	586.7	565.9	544.6	525.0	504.6
	kW	39.3	41.6	44.2	46.2	48.4	50.7	53.0	55.5	58.1	60.1	62.5

#### LEGEND

**kW** — Compressor Power  
**SST** — Saturated Suction Temperature Entering Condensing Unit  
**TC** — Gross Cooling Capacity (1000 Btuh)

#### NOTES:

1. Ratings are based on 15 F superheat and use of R-410A refrigerant.
2. Ratings include suction line losses due to an accumulator.
3. Refer to Commercial Split Builder program for more detailed information.

\* 38AP units are not designed for refrigeration duty. Unit operational range should be reviewed to ensure that operation at full and part load conditions with saturated suction temperatures at or below 30 F are avoided. Operation below 30 F SST may result in ice build-up on evaporator coil, resulting in liquid flood-back and possible compressor failure.

### 38APD115 CONDENSING UNIT CIRCUIT RATINGS, 60 Hz ENGLISH CIRCUIT A

SST (F)*		CONDENSER ENTERING-AIR TEMPERATURE (F)										
		70	80	85	90	95	100	105	110	115	120	125
30	TC	506.8	492.1	476.8	462.4	447.9	433.3	418.4	403.3	388.0	373.7	358.9
	kW	35.0	37.3	39.9	42.0	44.2	46.5	48.9	51.4	54.0	56.1	58.5
35	TC	557.6	541.5	524.8	509.2	493.4	477.3	461.1	444.7	427.9	412.4	396.2
	kW	36.0	38.4	41.0	43.1	45.3	47.6	50.0	52.5	55.1	57.2	59.5
40	TC	611.0	593.4	575.3	558.2	541.0	523.6	506.0	488.0	469.7	452.8	435.2
	kW	37.2	39.5	42.1	44.2	46.4	48.7	51.1	53.6	56.2	58.3	60.6
45	TC	663.7	644.9	628.0	609.4	580.1	571.7	552.4	532.8	512.7	494.3	475.5
	kW	38.3	40.7	43.3	45.4	47.9	49.8	52.2	54.7	57.3	59.4	61.7
50	TC	724.9	704.0	682.2	662.0	641.5	620.8	599.7	578.3	556.4	536.3	515.4
	kW	39.6	42.0	44.5	46.6	48.8	51.0	53.4	55.9	58.5	60.5	62.9

#### CIRCUIT B

SST (F)*		CONDENSER ENTERING-AIR TEMPERATURE (F)										
		70	80	85	90	95	100	105	110	115	120	125
30	TC	630.5	610.8	591.0	571.6	552.1	532.6	513.0	493.2	473.2	453.9	434.3
	kW	44.5	47.6	51.1	53.9	56.8	59.8	63.0	66.4	69.8	72.6	75.8
35	TC	695.7	674.2	652.5	631.3	610.1	588.8	567.3	545.6	523.8	502.8	481.3
	kW	45.6	48.8	52.2	55.0	57.9	61.0	64.2	67.5	71.0	73.8	76.9
40	TC	764.5	741.0	717.1	694.1	671.0	647.6	624.1	600.4	576.5	553.5	530.0
	kW	46.8	50.0	53.4	56.2	59.1	62.2	65.3	68.7	72.1	74.9	78.0
45	TC	840.2	814.1	784.1	758.7	747.0	707.9	682.2	656.3	630.0	604.9	578.8
	kW	48.1	51.2	54.6	57.4	60.7	63.4	66.5	69.8	73.3	76.0	79.2
50	TC	908.8	880.6	851.9	824.4	796.6	768.7	740.4	712.0	683.1	655.7	627.5
	kW	49.4	52.5	55.9	58.6	61.5	64.6	67.7	71.0	74.4	77.2	80.3

### 38APD130 CONDENSING UNIT CIRCUIT RATINGS, 60 Hz ENGLISH CIRCUIT A

SST (F)*		CONDENSER ENTERING-AIR TEMPERATURE (F)										
		70	80	85	90	95	100	105	110	115	120	125
30	TC	506.8	492.1	476.8	462.4	447.9	433.3	418.4	403.3	388.0	373.7	358.9
	kW	35.0	37.3	39.9	42.0	44.2	46.5	48.9	51.4	54.0	56.1	58.5
35	TC	557.6	541.5	524.8	509.2	493.4	477.3	461.1	444.7	427.9	412.4	396.2
	kW	36.0	38.4	41.0	43.1	45.3	47.6	50.0	52.5	55.1	57.2	59.5
40	TC	611.0	593.4	575.3	558.2	541.0	523.6	506.0	488.0	469.7	452.8	435.2
	kW	37.2	39.5	42.1	44.2	46.4	48.7	51.1	53.6	56.2	58.3	60.6
45	TC	663.7	644.9	628.0	609.4	580.1	571.7	552.4	532.8	512.7	494.3	475.5
	kW	38.3	40.7	43.3	45.4	47.9	49.8	52.2	54.7	57.3	59.4	61.7
50	TC	724.9	704.0	682.2	662.0	641.5	620.8	599.7	578.3	556.4	536.3	515.4
	kW	39.6	42.0	44.5	46.6	48.8	51.0	53.4	55.9	58.5	60.5	62.9

#### CIRCUIT B

SST (F)*		CONDENSER ENTERING-AIR TEMPERATURE (F)										
		70	80	85	90	95	100	105	110	115	120	125
30	TC	790.0	766.6	741.4	720.6	697.3	674.3	650.0	626.1	602.0	579.6	556.2
	kW	56.6	60.2	64.1	67.4	70.7	74.2	77.9	81.7	85.7	88.9	92.5
35	TC	871.2	845.5	819.2	793.7	768.6	743.5	716.6	690.7	664.8	639.4	613.7
	kW	58.4	62.0	66.0	69.2	72.5	76.0	79.7	83.5	87.5	90.6	94.2
40	TC	955.0	926.9	898.9	869.5	843.5	814.2	787.7	757.4	729.7	701.9	673.8
	kW	60.3	63.8	67.8	71.0	74.4	77.9	81.5	85.3	89.2	92.5	96.0
45	TC	1042.5	1012.3	981.3	951.7	929.9	888.1	854.9	825.8	808.3	770.6	740.4
	kW	62.1	65.7	69.7	72.9	76.5	79.7	83.4	87.2	91.2	94.3	97.9
50	TC	1132.6	1100.1	1057.8	1042.8	1012.1	963.3	945.9	894.2	875.9	840.4	807.9
	kW	64.4	68.0	71.7	75.2	78.6	81.7	85.7	89.1	93.2	96.3	99.9

#### LEGEND

**kW** — Compressor Power  
**SST** — Saturated Suction Temperature Entering Condensing Unit  
**TC** — Gross Cooling Capacity (1000 Btuh)

\* 38AP units are not designed for refrigeration duty. Unit operational range should be reviewed to ensure that operation at full and part load conditions with saturated suction temperatures at or below 30 F are avoided. Operation below 30 F SST may result in ice build-up on evaporator coil, resulting in liquid flood-back and possible compressor failure.

#### NOTES:

1. Ratings are based on 15 F superheat and use of R-410A refrigerant.
2. Ratings include suction line losses due to an accumulator.
3. Refer to Commercial Split Builder program for more detailed information.

# Performance data (cont)



## 38APD,APS025 CONDENSING UNIT RATINGS, 60 Hz SI

SST (C)*		CONDENSER ENTERING-AIR TEMPERATURE (C)										
		21	27	30	32	35	38	41	43	46	49	52
0	TC	78.2	73.2	70.7	69.0	66.4	63.8	61.1	59.3	56.5	53.6	50.7
	kW	16.8	18.8	19.9	20.7	21.8	23.0	24.3	25.1	26.5	27.8	29.1
2	TC	83.8	78.6	75.9	74.1	71.3	68.6	65.7	63.8	60.9	57.9	54.8
	kW	17.0	19.0	20.1	20.9	22.1	23.3	24.6	25.4	26.8	28.1	29.5
4	TC	89.5	84.0	81.1	79.2	76.3	73.4	70.4	68.4	65.3	62.1	58.8
	kW	17.2	19.3	20.3	21.1	22.3	23.5	24.8	25.7	27.1	28.4	29.8
6	TC	95.4	89.4	86.3	84.3	81.3	78.2	75.0	72.9	69.6	66.3	62.8
	kW	17.5	19.5	20.6	21.3	22.5	23.8	25.1	26.0	27.3	28.7	30.1
8	TC	101.1	94.7	91.5	89.4	86.1	82.8	79.5	77.2	73.8	70.3	66.7
	kW	17.7	19.7	20.8	21.6	22.8	24.0	25.3	26.2	27.6	29.0	30.4
10	TC	106.7	99.8	96.4	94.2	90.7	87.3	83.7	81.3	77.7	74.0	70.2
	kW	18.0	20.0	21.1	21.8	23.0	24.3	25.6	26.4	27.8	29.2	30.6

## 38APD,APS027 CONDENSING UNIT RATINGS, 60 Hz SI

SST (C)*		CONDENSER ENTERING-AIR TEMPERATURE (C)										
		21	27	30	32	35	38	41	43	46	49	52
0	TC	88.2	83.0	80.3	78.5	75.9	73.2	70.4	68.5	65.7	62.8	59.8
	kW	19.0	21.1	22.3	23.1	24.3	25.7	27.1	28.1	29.6	31.2	32.9
2	TC	94.1	88.5	85.7	83.8	81.0	78.1	75.2	73.2	70.1	67.0	63.9
	kW	19.4	21.5	22.6	23.4	24.7	26.1	27.5	28.4	30.0	31.5	33.2
4	TC	100.1	94.1	91.1	89.1	86.1	83.0	79.9	77.8	74.6	71.3	67.9
	kW	19.8	21.9	23.0	23.8	25.1	26.4	27.8	28.8	30.3	31.9	33.5
6	TC	106.1	99.7	96.5	94.4	91.1	87.9	84.6	82.4	79.0	75.5	71.9
	kW	20.2	22.3	23.4	24.2	25.5	26.8	28.2	29.2	30.7	32.3	33.9
8	TC	112.1	105.2	101.8	99.6	96.1	92.7	89.2	86.8	83.2	79.5	75.8
	kW	20.7	22.7	23.9	24.7	25.9	27.3	28.6	29.6	31.1	32.6	34.3
10	TC	118.0	110.6	107.1	104.7	101.0	97.3	93.6	91.1	87.3	83.4	79.4
	kW	21.2	23.2	24.4	25.2	26.4	27.7	29.1	30.0	31.5	33.0	34.6

## 38APD,APS030 CONDENSING UNIT RATINGS, 60 Hz SI

SST (C)*		CONDENSER ENTERING-AIR TEMPERATURE (C)										
		21	27	30	32	35	38	41	43	46	49	52
0	TC	102.5	96.6	93.6	91.6	88.7	85.6	82.4	80.3	77.1	73.8	70.5
	kW	22.9	25.5	27.0	28.0	29.6	31.3	33.0	34.3	36.2	38.2	40.3
2	TC	109.2	102.9	99.8	97.7	94.6	91.3	88.0	85.8	82.4	79.0	75.4
	kW	23.4	26.0	27.5	28.5	30.1	31.8	33.5	34.7	36.7	38.7	40.7
4	TC	115.9	109.3	106.0	103.8	100.5	97.1	93.7	91.3	87.8	84.1	80.3
	kW	23.9	26.5	28.0	29.0	30.6	32.2	34.0	35.2	37.1	39.1	41.1
6	TC	122.5	115.6	112.2	109.9	106.4	102.9	99.3	96.8	93.1	89.2	85.1
	kW	24.4	27.0	28.5	29.5	31.1	32.7	34.5	35.7	37.6	39.6	41.7
8	TC	129.2	121.8	118.3	115.8	112.2	108.6	104.8	102.2	98.3	94.3	90.0
	kW	25.0	27.6	29.0	30.0	31.6	33.3	35.0	36.2	38.1	40.1	42.0
10	TC	135.7	128.1	124.4	121.8	118.0	114.1	110.2	107.5	103.4	99.2	—
	kW	25.6	28.2	29.6	30.6	32.2	33.8	35.6	36.8	38.6	40.6	—

### LEGEND

- kW** — Compressor Power
- SST** — Saturated Suction Temperature Entering Condensing Unit
- TC** — Gross Cooling Capacity (kW)

### NOTES:

1. Ratings are based on 8.3 C superheat and use of R-410A refrigerant.
2. Ratings include suction line losses due to an accumulator.
3. Refer to Commercial Split Builder program for more detailed information.

\* 38AP units are not designed for refrigeration duty. Unit operational range should be reviewed to ensure that operation at full and part load conditions with saturated suction temperatures at or below 0° C are avoided. Operation below 0° C SST may result in ice build-up on evaporator coil, resulting in liquid flood-back and possible compressor failure.



### 38APD040 CONDENSING UNIT RATINGS, 60 Hz SI

SST (C)*		CONDENSER ENTERING-AIR TEMPERATURE (C)										
		21	27	30	32	35	38	41	43	46	49	52
0	TC	128.4	120.4	116.2	113.5	109.3	105.0	100.6	97.6	93.0	88.5	83.7
	kW	26.4	30.0	31.9	33.2	35.3	37.4	39.6	41.2	43.5	45.9	48.3
2	TC	137.4	128.9	124.5	121.5	117.1	112.5	107.9	104.8	99.9	94.9	90.1
	kW	26.8	30.4	32.3	33.6	35.7	37.9	40.1	41.7	44.0	46.5	49.0
4	TC	146.6	137.7	132.8	129.7	124.9	120.2	115.3	112.0	107.0	101.6	96.3
	kW	27.2	30.8	32.7	34.1	36.2	38.4	40.6	42.2	44.6	47.0	49.6
6	TC	156.2	146.4	141.3	138.0	133.1	128.0	122.8	119.2	113.7	108.0	102.3
	kW	27.7	31.3	33.2	34.5	36.6	38.8	41.1	42.7	45.1	47.5	50.1
8	TC	165.9	155.3	150.1	146.3	141.2	135.8	130.3	126.4	120.3	114.8	108.7
	kW	28.1	31.7	33.6	35.0	37.1	39.3	41.6	43.1	45.5	48.1	50.6
10	TC	175.4	164.3	158.8	155.0	149.4	143.2	137.2	133.2	127.6	120.8	114.9
	kW	28.6	32.2	34.1	35.5	37.6	39.7	42.0	43.6	46.0	48.5	51.1

### 38APS040 CONDENSING UNIT RATINGS, 60 Hz SI

SST (C)*		CONDENSER ENTERING-AIR TEMPERATURE (C)										
		21	27	30	32	35	38	41	43	46	49	52
0	TC	107.2	100.8	97.4	95.2	91.8	88.3	84.8	82.5	79.0	75.4	71.7
	kW	21.3	23.8	25.1	26.1	27.6	29.2	30.9	32.0	33.8	35.8	37.8
2	TC	114.6	107.7	104.1	101.8	98.0	94.4	90.6	88.1	84.4	80.6	76.7
	kW	21.7	24.2	25.6	26.5	28.0	29.6	31.3	32.5	34.3	36.2	38.2
4	TC	122.2	114.9	111.0	108.4	104.5	100.5	96.7	93.9	90.1	86.0	81.5
	kW	22.2	24.7	26.0	27.0	28.5	30.1	31.8	32.9	34.7	36.6	38.6
6	TC	130.2	122.2	118.1	115.3	111.1	107.2	102.9	99.9	95.9	91.5	86.7
	kW	22.7	25.2	26.5	27.5	29.0	30.6	32.2	33.4	35.2	37.1	39.1
8	TC	138.4	130.1	125.4	122.5	118.3	113.9	109.4	106.1	101.5	96.8	92.0
	kW	23.2	25.7	27.1	28.0	29.5	31.1	32.8	33.9	35.7	37.6	39.6
10	TC	146.9	137.6	132.9	129.8	125.4	120.7	115.9	112.3	107.5	102.8	97.4
	kW	23.8	26.3	27.6	28.6	30.1	31.6	33.3	34.4	36.2	38.1	40.1

### 38APD050 CONDENSING UNIT RATINGS, 60 Hz SI

SST (C)*		CONDENSER ENTERING-AIR TEMPERATURE (C)										
		21	27	30	32	35	38	41	43	46	49	52
0	TC	164.5	154.4	149.2	145.7	140.3	134.8	129.5	125.7	119.9	114.1	108.0
	kW	37.4	41.8	44.2	45.9	48.5	51.1	53.9	55.8	58.8	61.8	64.9
2	TC	175.9	165.1	159.5	155.7	150.2	144.2	138.3	134.3	128.6	122.4	116.0
	kW	38.1	42.6	44.9	46.6	49.2	51.9	54.7	56.6	59.6	62.6	65.7
4	TC	187.4	175.9	169.9	165.7	160.0	154.0	147.5	143.6	136.7	130.3	123.2
	kW	38.8	43.3	45.7	47.3	49.9	52.6	55.4	57.4	60.3	63.4	66.5
6	TC	199.2	186.8	180.6	176.4	170.1	163.6	156.6	152.1	145.2	138.7	131.1
	kW	39.6	44.0	46.4	48.1	50.7	53.4	56.2	58.1	61.1	64.2	67.3
8	TC	211.2	197.8	191.4	186.9	180.2	173.0	165.8	161.5	154.2	146.6	—
	kW	40.3	44.7	47.2	48.8	51.4	54.1	56.9	58.9	61.9	64.9	—
10	TC	223.3	208.9	202.0	197.4	189.9	182.4	175.3	169.8	162.3	154.6	—
	kW	41.1	45.5	48.0	49.6	52.2	54.9	57.7	59.6	62.6	65.7	—

#### LEGEND

**kW** — Compressor Power  
**SST** — Saturated Suction Temperature Entering Condensing Unit  
**TC** — Gross Cooling Capacity (kW)

#### NOTES:

1. Ratings are based on 8.3 C superheat and use of R-410A refrigerant.
2. Ratings include suction line losses due to an accumulator.
3. Refer to Commercial Split Builder program for more detailed information.

\* 38AP units are not designed for refrigeration duty. Unit operational range should be reviewed to ensure that operation at full and part load conditions with saturated suction temperatures at or below 0° C are avoided. Operation below 0° C SST may result in ice build-up on evaporator coil, resulting in liquid flood-back and possible compressor failure.



# Performance data (cont)



## 38APS050 CONDENSING UNIT RATINGS, 60 Hz SI

SST (C)*		CONDENSER ENTERING-AIR TEMPERATURE (C)										
		21	27	30	32	35	38	41	43	46	49	52
0	TC	156.0	147.2	142.0	138.8	133.2	129.0	124.4	116.8	111.8	111.1	104.9
	kW	34.8	38.9	41.1	42.6	44.9	47.0	50.2	52.6	54.2	57.8	60.5
2	TC	167.4	157.5	152.2	149.1	143.9	138.6	132.8	129.3	123.7	116.2	113.4
	kW	35.6	39.7	41.8	43.4	45.8	48.3	50.8	52.6	55.4	58.0	61.4
4	TC	178.3	168.0	162.4	158.7	153.2	147.9	142.3	138.4	132.0	126.4	120.1
	kW	36.3	40.4	42.5	44.0	46.4	48.9	51.5	53.3	56.0	58.9	61.9
6	TC	189.8	178.5	173.1	169.1	163.4	156.9	150.8	146.7	140.3	134.3	127.6
	kW	37.0	41.0	43.2	44.8	47.1	49.6	52.1	53.9	56.7	59.6	62.5
8	TC	201.4	189.3	183.5	179.2	173.0	166.2	159.6	155.2	148.9	141.9	134.8
	kW	37.8	41.8	44.0	45.5	47.8	50.2	52.8	54.6	57.4	60.2	63.1
10	TC	213.0	200.0	193.8	189.2	182.1	175.2	168.1	163.4	156.6	148.6	141.6
	kW	38.6	42.5	44.7	46.2	48.5	50.9	53.5	55.2	58.0	60.7	63.7

## 38APD060 CONDENSING UNIT RATINGS, 60 Hz SI

SST (C)*		CONDENSER ENTERING-AIR TEMPERATURE (C)										
		21	27	30	32	35	38	41	43	46	49	52
0	TC	189.2	177.3	173.9	168.6	164.4	156.6	152.5	147.9	142.2	135.6	130.0
	kW	42.1	46.8	49.5	51.1	54.0	56.9	60.0	62.3	65.7	69.1	72.0
2	TC	200.0	189.7	185.9	179.8	175.6	167.1	162.9	157.9	152.2	145.8	139.4
	kW	44.0	47.7	50.4	52.1	55.0	57.8	60.9	63.0	66.3	69.6	73.3
4	TC	209.4	202.2	197.9	191.3	186.9	179.2	173.0	168.2	162.5	153.7	148.5
	kW	43.9	48.7	51.4	53.1	55.9	58.8	61.9	64.2	67.4	71.0	74.4
6	TC	223.5	210.8	209.1	203.7	198.5	190.4	183.4	178.6	172.3	165.0	158.0
	kW	44.9	49.7	52.4	54.1	57.0	59.9	63.0	65.0	68.2	71.5	75.2
8	TC	241.4	222.2	219.3	214.9	210.2	200.2	195.4	187.3	182.7	173.4	167.2
	kW	46.2	50.7	53.4	55.2	58.1	60.9	64.1	66.1	69.4	73.0	76.3
10	TC	255.1	235.1	230.8	225.4	222.6	211.3	207.4	197.9	193.2	181.6	—
	kW	47.3	51.9	54.6	56.3	59.3	62.0	65.3	67.3	70.5	74.0	—

## 38APS065 CONDENSING UNIT RATINGS, 60 Hz SI

SST (C)*		CONDENSER ENTERING-AIR TEMPERATURE (C)										
		21	27	30	32	35	38	41	43	46	49	52
0	TC	162.6	151.9	146.5	142.9	137.3	132.0	126.3	122.7	117.2	111.4	105.5
	kW	36.1	40.2	42.4	43.9	46.3	48.8	51.4	53.3	56.1	59.0	62.1
2	TC	173.8	162.5	156.7	152.9	147.0	141.3	135.3	131.3	125.4	119.2	113.3
	kW	36.9	41.0	43.2	44.7	47.1	49.7	52.3	54.1	56.9	59.8	62.9
4	TC	185.6	173.4	167.3	163.2	157.1	150.9	144.6	140.6	134.1	127.5	121.4
	kW	37.8	41.9	44.1	45.6	48.0	50.5	53.1	55.0	57.8	60.7	63.8
6	TC	197.8	184.8	178.3	174.1	167.4	160.8	154.2	150.0	143.0	136.3	129.2
	kW	38.7	42.8	45.0	46.5	48.9	51.4	54.0	55.9	58.7	61.6	64.6
8	TC	210.4	196.4	189.8	185.3	178.1	171.1	163.8	159.2	152.0	145.0	137.4
	kW	39.7	43.7	45.9	47.5	49.9	52.4	55.0	56.8	59.6	62.5	65.5
10	TC	223.7	208.8	201.8	196.5	188.7	181.4	173.5	168.9	161.5	153.6	145.9
	kW	40.7	44.7	47.0	48.5	50.8	53.3	55.9	57.8	60.6	63.4	66.4

### LEGEND

- kW** — Compressor Power
- SST** — Saturated Suction Temperature Entering Condensing Unit
- TC** — Gross Cooling Capacity (kW)

### NOTES:

1. Ratings are based on 8.3 C superheat and use of R-410A refrigerant.
2. Ratings include suction line losses due to an accumulator.
3. Refer to Commercial Split Builder program for more detailed information.

\* 38AP units are not designed for refrigeration duty. Unit operational range should be reviewed to ensure that operation at full and part load conditions with saturated suction temperatures at or below 0° C are avoided. Operation below 0° C SST may result in ice build-up on evaporator coil, resulting in liquid flood-back and possible compressor failure.

### 38APD070 CONDENSING UNIT RATINGS, 60 Hz SI

SST (C)*		CONDENSER ENTERING-AIR TEMPERATURE (C)										
		21	27	30	32	35	38	41	43	46	49	52
0	TC	218.2	204.8	198.0	193.4	186.4	179.3	172.1	167.3	159.9	152.4	144.6
	kW	49.7	55.5	58.7	60.9	64.3	67.8	71.5	74.1	78.0	82.0	86.1
2	TC	233.5	219.3	212.0	207.1	199.8	192.2	184.7	179.6	171.8	163.7	155.6
	kW	50.7	56.6	59.7	61.9	65.4	69.0	72.7	75.3	79.2	83.3	87.5
4	TC	249.2	234.1	226.4	221.3	213.5	205.6	197.5	192.1	183.8	175.4	166.6
	kW	51.8	57.7	60.9	63.1	66.5	70.1	73.9	76.5	80.5	84.6	88.8
6	TC	265.3	249.3	241.2	235.7	227.5	219.1	210.6	204.9	196.1	187.1	177.7
	kW	52.9	58.8	62.0	64.2	67.7	71.3	75.1	77.7	81.7	85.9	90.2
8	TC	281.7	264.8	256.2	250.5	241.7	232.9	223.9	217.8	208.6	199.1	—
	kW	54.1	60.0	63.2	65.4	68.9	72.5	76.3	78.9	83.0	87.2	—
10	TC	298.5	280.5	271.4	265.4	256.1	246.8	237.3	230.9	221.1	210.9	—
	kW	55.3	61.2	64.4	66.7	70.1	73.8	77.6	80.2	84.2	88.4	—

### 38APD080 CONDENSING UNIT RATINGS, 60 Hz SI

SST (C)*		CONDENSER ENTERING-AIR TEMPERATURE (C)										
		21	27	30	32	35	38	41	43	46	49	52
0	TC	256.3	241.9	234.4	230.9	221.1	213.0	205.1	201.6	191.2	182.6	177.1
	kW	56.3	62.9	66.4	68.9	72.7	76.8	81.0	83.8	88.5	93.2	97.8
2	TC	274.1	258.3	250.2	246.3	235.6	227.2	218.8	215.1	207.4	194.7	189.2
	kW	57.5	64.0	67.5	70.0	73.8	77.9	82.1	84.9	89.5	94.3	98.8
4	TC	292.7	274.7	268.1	261.5	253.8	241.4	235.8	226.6	220.5	207.5	201.2
	kW	58.8	65.2	68.7	71.2	75.0	79.0	83.2	86.2	90.6	95.5	100.0
6	TC	310.3	291.2	284.7	276.2	268.9	255.4	249.9	239.2	233.5	219.3	213.0
	kW	60.1	66.4	70.1	72.4	76.3	80.1	84.4	87.3	91.8	96.6	101.1
8	TC	327.7	307.1	299.7	292.2	283.4	273.8	261.5	255.3	246.0	233.9	222.5
	kW	61.4	67.7	71.3	73.6	77.5	81.6	85.6	88.4	92.9	97.7	102.5
10	TC	344.3	323.3	316.3	308.4	298.9	282.8	276.0	268.9	258.4	241.9	235.7
	kW	62.5	69.0	72.9	75.2	79.0	82.5	86.8	89.9	94.3	98.8	103.5

### 38APD090 CONDENSING UNIT RATINGS, 60 Hz SI

SST (C)*		CONDENSER ENTERING-AIR TEMPERATURE (C)										
		21	27	30	32	35	38	41	43	46	49	52
0	TC	286.2	269.7	260.7	257.2	248.9	237.2	228.2	224.5	213.2	202.5	196.1
	kW	61.1	68.7	72.7	75.6	79.9	84.7	89.6	92.9	98.2	103.5	108.5
2	TC	305.8	287.1	281.0	272.1	262.5	256.3	243.7	239.1	228.9	218.3	208.1
	kW	62.3	69.7	73.8	76.6	81.0	85.6	90.6	93.8	99.1	104.4	109.7
4	TC	325.8	305.6	298.5	290.1	282.3	268.6	262.2	250.7	244.1	230.1	222.7
	kW	63.4	70.8	74.9	77.7	82.1	86.7	91.5	94.8	99.8	105.3	110.4
6	TC	345.8	323.2	315.7	307.7	298.6	283.9	277.1	264.7	258.0	243.1	235.6
	kW	64.8	72.0	76.1	78.8	83.3	87.7	92.6	95.8	100.8	106.3	111.5
8	TC	364.9	341.6	333.5	323.0	314.1	303.3	286.2	282.4	271.7	253.6	247.1
	kW	66.1	73.3	77.5	80.0	84.5	89.0	93.5	96.9	102.0	107.2	112.3
10	TC	381.4	357.7	349.3	341.1	330.1	314.7	302.0	294.0	283.3	272.3	252.2
	kW	67.1	74.5	78.8	81.5	85.8	90.1	94.7	97.8	102.9	108.3	113.6

**LEGEND**

- kW** — Compressor Power
- SST** — Saturated Suction Temperature Entering Condensing Unit
- TC** — Gross Cooling Capacity (kW)

**NOTES:**

1. Ratings are based on 8.3 C superheat and use of R-410A refrigerant.
2. Ratings include suction line losses due to an accumulator.
3. Refer to Commercial Split Builder program for more detailed information.

\* 38AP units are not designed for refrigeration duty. Unit operational range should be reviewed to ensure that operation at full and part load conditions with saturated suction temperatures at or below 0° C are avoided. Operation below 0° C SST may result in ice build-up on evaporator coil, resulting in liquid flood-back and possible compressor failure.

# Performance data (cont)



## 38APD100 CONDENSING UNIT RATINGS, 60 Hz SI

SST (C)*		CONDENSER ENTERING-AIR TEMPERATURE (C)										
		21	27	30	32	35	38	41	43	46	49	52
0	TC	315.3	295.3	287.1	280.1	271.6	261.1	252.7	244.9	236.6	225.0	216.6
	kW	65.0	77.0	80.8	83.9	89.0	93.9	98.6	102.6	107.7	114.1	119.6
2	TC	336.4	316.4	307.6	298.4	291.2	279.8	270.9	262.4	253.9	240.8	232.6
	kW	66.6	78.6	82.9	85.7	90.5	95.4	100.2	104.2	109.3	115.8	121.0
4	TC	353.0	333.0	329.3	319.7	311.7	298.8	289.9	282.0	271.7	260.5	248.9
	kW	67.7	79.7	84.6	87.3	92.0	97.0	101.6	105.2	110.4	116.1	121.9
6	TC	378.6	358.6	351.2	340.7	332.5	320.9	309.4	300.7	289.9	277.8	265.8
	kW	69.6	81.6	86.1	89.0	93.7	98.4	103.4	106.8	112.0	117.9	123.6
8	TC	402.8	382.8	373.6	364.5	353.3	341.1	329.0	320.2	308.5	295.6	282.8
	kW	71.4	83.4	87.9	90.7	95.1	99.8	104.8	107.8	113.8	119.4	125.4
10	TC	424.0	404.0	394.4	386.0	375.3	361.9	349.2	339.0	326.7	313.3	300.1
	kW	71.7	83.7	89.6	92.4	97.3	101.9	106.9	110.2	115.5	120.8	127.2

## 38APD115 CONDENSING UNIT RATINGS, 60 Hz SI

SST (C)*		CONDENSER ENTERING-AIR TEMPERATURE (C)										
		21	27	30	32	35	38	41	43	46	49	52
0	TC	354.3	331.7	321.4	315.9	303.1	291.8	280.4	275.1	262.3	249.1	237.4
	kW	78.6	88.0	93.2	96.8	102.3	108.2	114.3	118.4	125.3	132.0	139.1
2	TC	374.2	355.9	344.5	338.9	325.1	313.1	300.8	295.7	281.5	268.3	255.7
	kW	79.6	89.5	94.6	98.3	103.8	109.6	115.7	119.9	126.7	133.4	140.5
4	TC	403.2	381.1	368.0	362.8	347.0	334.9	322.2	316.6	300.4	287.1	273.3
	kW	81.3	91.0	96.1	99.8	105.3	111.1	117.2	121.3	128.0	134.9	142.0
6	TC	432.8	406.2	392.8	386.9	370.7	361.7	343.8	337.7	320.0	311.1	290.8
	kW	83.2	92.5	97.6	101.3	106.7	112.6	118.8	122.8	129.5	135.8	143.3
8	TC	459.1	431.3	422.2	409.7	398.7	381.4	368.5	356.6	345.9	325.3	315.7
	kW	84.6	94.1	99.5	102.8	108.5	114.2	120.2	124.4	130.7	137.8	144.3
10	TC	488.1	457.8	446.6	435.5	422.3	403.7	390.0	377.5	365.7	343.3	333.6
	kW	86.5	95.7	101.1	104.5	110.1	115.7	121.8	125.9	132.3	139.1	145.6

## 38APD130 CONDENSING UNIT RATINGS, 60 Hz SI

SST (C)*		CONDENSER ENTERING-AIR TEMPERATURE (C)										
		21	27	30	32	35	38	41	43	46	49	52
0	TC	402.9	379.0	367.3	361.4	347.1	334.6	322.0	313.9	300.0	287.9	273.6
	kW	90.7	101.0	106.6	110.6	116.5	122.8	129.5	134.1	141.2	148.6	156.3
2	TC	425.6	405.9	393.4	387.4	371.9	358.6	345.0	339.2	322.2	308.5	294.3
	kW	92.1	102.9	108.5	112.5	118.4	124.8	131.4	135.9	143.1	150.5	158.2
4	TC	458.3	433.7	420.8	414.3	397.5	383.0	368.9	362.8	344.7	329.6	314.3
	kW	94.3	104.9	110.5	114.5	120.4	126.7	133.3	137.8	145.0	152.4	160.1
6	TC	492.3	463.1	448.1	441.5	422.8	408.1	393.2	386.8	367.3	350.9	334.4
	kW	96.7	106.9	112.5	116.5	122.3	128.7	135.3	139.8	146.9	154.3	161.9
8	TC	522.3	492.5	476.8	469.3	449.2	434.2	417.0	410.7	389.6	379.0	354.5
	kW	98.7	109.0	114.5	118.6	124.3	130.7	137.3	141.8	148.9	155.9	163.9
10	TC	553.8	521.8	509.4	496.8	482.1	460.8	446.3	431.8	419.8	394.9	382.7
	kW	100.9	111.2	117.1	120.7	126.9	132.8	139.6	143.9	151.2	158.3	165.5

### LEGEND

- kW** — Compressor Power
- SST** — Saturated Suction Temperature Entering Condensing Unit
- TC** — Gross Cooling Capacity (kW)

### NOTES:

1. Ratings are based on 8.3 C superheat and use of R-410A refrigerant.
2. Ratings include suction line losses due to an accumulator.
3. Refer to Commercial Split Builder program for more detailed information.

\* 38AP units are not designed for refrigeration duty. Unit operational range should be reviewed to ensure that operation at full and part load conditions with saturated suction temperatures at or below 0° C are avoided. Operation below 0° C SST may result in ice build-up on evaporator coil, resulting in liquid flood-back and possible compressor failure.

**38APD025 CONDENSING UNIT CIRCUIT RATINGS, 60 Hz SI  
CIRCUIT A**

SST (C)*		CONDENSER ENTERING-AIR TEMPERATURE (C)										
		21	27	30	32	35	38	41	43	46	49	52
0	TC	39.1	36.6	35.4	34.5	33.2	31.9	30.5	29.6	28.2	26.8	25.4
	kW	8.4	9.4	10.0	10.3	10.9	11.5	12.2	12.6	13.2	13.9	14.6
2	TC	41.9	39.3	37.9	37.0	35.7	34.3	32.9	31.9	30.4	29.0	27.4
	kW	8.5	9.5	10.1	10.4	11.0	11.7	12.3	12.7	13.4	14.1	14.7
4	TC	44.8	42.0	40.6	39.6	38.2	36.7	35.2	34.2	32.6	31.1	29.4
	kW	8.6	9.6	10.2	10.6	11.2	11.8	12.4	12.9	13.5	14.2	14.9
6	TC	47.7	44.7	43.2	42.2	40.6	39.1	37.5	36.4	34.8	33.2	31.4
	kW	8.7	9.7	10.3	10.7	11.3	11.9	12.5	13.0	13.7	14.4	15.1
8	TC	50.6	47.4	45.7	44.7	43.1	41.4	39.8	38.6	36.9	35.1	33.3
	kW	8.9	9.9	10.4	10.8	11.4	12.0	12.7	13.1	13.8	14.5	15.2
10	TC	53.4	49.9	48.2	47.1	45.4	43.6	41.9	40.7	38.8	37.0	35.1
	kW	9.0	10.0	10.5	10.9	11.5	12.1	12.8	13.2	13.9	14.6	15.3

**CIRCUIT B**

SST (C)*		CONDENSER ENTERING-AIR TEMPERATURE (C)										
		21	27	30	32	35	38	41	43	46	49	52
0	TC	39.1	36.6	35.4	34.5	33.2	31.9	30.5	29.6	28.2	26.8	25.4
	kW	8.4	9.4	10.0	10.3	10.9	11.5	12.2	12.6	13.2	13.9	14.6
2	TC	41.9	39.3	37.9	37.0	35.7	34.3	32.9	31.9	30.4	29.0	27.4
	kW	8.5	9.5	10.1	10.4	11.0	11.7	12.3	12.7	13.4	14.1	14.7
4	TC	44.8	42.0	40.6	39.6	38.2	36.7	35.2	34.2	32.6	31.1	29.4
	kW	8.6	9.6	10.2	10.6	11.2	11.8	12.4	12.9	13.5	14.2	14.9
6	TC	47.7	44.7	43.2	42.2	40.6	39.1	37.5	36.4	34.8	33.2	31.4
	kW	8.7	9.7	10.3	10.7	11.3	11.9	12.5	13.0	13.7	14.4	15.1
8	TC	50.6	47.4	45.7	44.7	43.1	41.4	39.8	38.6	36.9	35.1	33.3
	kW	8.9	9.9	10.4	10.8	11.4	12.0	12.7	13.1	13.8	14.5	15.2
10	TC	53.4	49.9	48.2	47.1	45.4	43.6	41.9	40.7	38.8	37.0	35.1
	kW	9.0	10.0	10.5	10.9	11.5	12.1	12.8	13.2	13.9	14.6	15.3

**LEGEND**

- kW** — Compressor Power
- SST** — Saturated Suction Temperature Entering Condensing Unit
- TC** — Gross Cooling Capacity (kW)

\* 38AP units are not designed for refrigeration duty. Unit operational range should be reviewed to ensure that operation at full and part load conditions with saturated suction temperatures at or below 0° C are avoided. Operation below 0° C SST may result in ice build-up on evaporator coil, resulting in liquid flood-back and possible compressor failure.

**NOTES:**

1. Ratings are based on 8.3 C superheat and use of R-410A refrigerant.
2. Ratings include suction line losses due to an accumulator.
3. Refer to Commercial Split Builder program for more detailed information.

# Performance data (cont)



## 38APD027 CONDENSING UNIT CIRCUIT RATINGS, 60 Hz SI CIRCUIT A

SST (C)*		CONDENSER ENTERING-AIR TEMPERATURE (C)										
		21	27	30	32	35	38	41	43	46	49	52
0	TC	44.2	41.6	40.3	39.4	38.1	36.7	35.4	34.4	33.0	31.6	30.1
	kW	9.5	10.6	11.1	11.6	12.2	12.9	13.6	14.1	14.8	15.6	16.5
2	TC	47.2	44.5	43.1	42.1	40.7	39.3	37.8	36.8	35.3	33.8	32.2
	kW	9.7	10.8	11.3	11.7	12.4	13.0	13.7	14.2	15.0	15.8	16.6
4	TC	50.3	47.3	45.8	44.9	43.4	41.8	40.3	39.2	37.6	36.0	34.3
	kW	9.9	10.9	11.5	11.9	12.6	13.2	13.9	14.4	15.2	16.0	16.8
6	TC	53.4	50.2	48.6	47.6	46.0	44.4	42.7	41.6	39.9	38.2	36.4
	kW	10.1	11.2	11.7	12.1	12.8	13.4	14.1	14.6	15.4	16.2	17.0
8	TC	56.5	53.0	51.4	50.2	48.5	46.8	45.1	43.9	42.1	40.3	38.4
	kW	10.4	11.4	12.0	12.3	13.0	13.6	14.3	14.8	15.6	16.3	17.1
10	TC	59.4	55.8	54.1	52.9	51.1	49.3	47.4	46.2	44.3	42.3	40.3
	kW	10.6	11.6	12.2	12.6	13.2	13.9	14.5	15.0	15.8	16.5	17.3

## CIRCUIT B

SST (C)*		CONDENSER ENTERING-AIR TEMPERATURE (C)										
		21	27	30	32	35	38	41	43	46	49	52
0	TC	44.0	41.3	40.0	39.1	37.8	36.4	35.0	34.1	32.7	31.2	29.7
	kW	9.5	10.5	11.1	11.5	12.2	12.8	13.5	14.0	14.8	15.6	16.4
2	TC	46.9	44.1	42.6	41.7	40.3	38.8	37.3	36.3	34.8	33.3	31.7
	kW	9.7	10.7	11.3	11.7	12.3	13.0	13.7	14.2	15.0	15.7	16.6
4	TC	49.8	46.8	45.2	44.2	42.7	41.2	39.6	38.6	37.0	35.3	33.6
	kW	9.9	10.9	11.5	11.9	12.5	13.2	13.9	14.4	15.1	15.9	16.7
6	TC	52.7	49.5	47.9	46.8	45.2	43.5	41.9	40.7	39.0	37.3	35.5
	kW	10.1	11.1	11.7	12.1	12.7	13.4	14.1	14.6	15.3	16.1	16.9
8	TC	55.7	52.1	50.5	49.3	47.6	45.9	44.1	42.9	41.1	39.2	37.3
	kW	10.3	11.4	11.9	12.3	13.0	13.6	14.3	14.8	15.5	16.3	17.1
10	TC	58.5	54.8	53.0	51.8	50.0	48.1	46.2	45.0	43.0	41.1	39.1
	kW	10.6	11.6	12.2	12.6	13.2	13.8	14.5	15.0	15.7	16.5	17.3

### LEGEND

- kW — Compressor Power
- SST — Saturated Suction Temperature Entering Condensing Unit
- TC — Gross Cooling Capacity (kW)

### NOTES:

1. Ratings are based on 8.3 C superheat and use of R-410A refrigerant.
2. Ratings include suction line losses due to an accumulator.
3. Refer to Commercial Split Builder program for more detailed information.

\* 38AP units are not designed for refrigeration duty. Unit operational range should be reviewed to ensure that operation at full and part load conditions with saturated suction temperatures at or below 0° C are avoided. Operation below 0° C SST may result in ice build-up on evaporator coil, resulting in liquid flood-back and possible compressor failure.

**38APD030 CONDENSING UNIT CIRCUIT RATINGS, 60 Hz SI**  
**CIRCUIT A**

SST (C)*		CONDENSER ENTERING-AIR TEMPERATURE (C)										
		21	27	30	32	35	38	41	43	46	49	52
0	TC	51.2	48.3	46.8	45.8	44.3	42.8	41.2	40.1	38.5	36.9	35.2
	kW	11.4	12.7	13.4	13.9	14.7	15.5	16.4	17.0	18.0	19.0	20.0
2	TC	54.5	51.4	49.9	48.8	47.3	45.6	44.0	42.9	41.2	39.5	37.7
	kW	11.6	12.9	13.6	14.2	14.9	15.8	16.7	17.3	18.2	19.2	20.2
4	TC	57.9	54.5	52.9	51.9	50.2	48.5	46.8	45.7	43.9	42.0	40.2
	kW	11.9	13.2	13.9	14.4	15.2	16.0	16.9	17.5	18.4	19.4	20.4
6	TC	61.2	57.7	56.0	54.9	53.1	51.4	49.6	48.4	46.5	44.6	42.6
	kW	12.1	13.4	14.1	14.6	15.4	16.2	17.1	17.7	18.7	19.7	20.7
8	TC	64.4	60.8	59.0	57.8	56.0	54.2	52.3	51.1	49.1	47.1	45.0
	kW	12.4	13.7	14.4	14.9	15.7	16.5	17.4	18.0	18.9	19.9	21.0
10	TC	67.7	63.9	62.0	60.8	58.9	57.0	55.0	53.7	51.7	49.6	—
	kW	12.7	14.0	14.7	15.2	16.0	16.8	17.6	18.2	19.2	20.1	—

**CIRCUIT B**

SST (C)*		CONDENSER ENTERING-AIR TEMPERATURE (C)										
		21	27	30	32	35	38	41	43	46	49	52
0	TC	51.3	48.3	46.8	45.9	44.4	42.8	41.2	40.2	38.6	36.9	35.3
	kW	11.5	12.9	13.6	14.1	14.9	15.7	16.6	17.2	18.2	19.2	20.2
2	TC	54.7	51.5	50.0	48.9	47.3	45.7	44.0	42.9	41.2	39.5	37.7
	kW	11.8	13.1	13.8	14.3	15.1	16.0	16.9	17.5	18.4	19.4	20.5
4	TC	58.0	54.7	53.1	52.0	50.3	48.6	46.9	45.7	43.9	42.0	40.1
	kW	12.0	13.3	14.1	14.6	15.4	16.2	17.1	17.7	18.7	19.7	20.7
6	TC	61.4	57.9	56.2	55.0	53.3	51.5	49.7	48.4	46.6	44.6	42.5
	kW	12.3	13.6	14.3	14.8	15.6	16.5	17.4	18.0	18.9	19.9	21.0
8	TC	64.7	61.1	59.3	58.0	56.2	54.3	52.4	51.1	49.2	47.1	45.0
	kW	12.6	13.9	14.6	15.1	15.9	16.7	17.6	18.2	19.2	20.2	21.0
10	TC	68.1	64.2	62.3	61.1	59.1	57.2	55.1	53.8	51.7	49.6	—
	kW	12.9	14.2	14.9	15.4	16.2	17.0	17.9	18.5	19.5	20.4	—

**LEGEND**

**kW** — Compressor Power  
**SST** — Saturated Suction Temperature Entering Condensing Unit  
**TC** — Gross Cooling Capacity (kW)

**NOTES:**

1. Ratings are based on 8.3 C superheat and use of R-410A refrigerant.
2. Ratings include suction line losses due to an accumulator.
3. Refer to Commercial Split Builder program for more detailed information.

\* 38AP units are not designed for refrigeration duty. Unit operational range should be reviewed to ensure that operation at full and part load conditions with saturated suction temperatures at or below 0° C are avoided. Operation below 0° C SST may result in ice build-up on evaporator coil, resulting in liquid flood-back and possible compressor failure.

# Performance data (cont)



## 38APD040 CONDENSING UNIT CIRCUIT RATINGS, 60 Hz SI CIRCUIT A

SST (C)*		CONDENSER ENTERING-AIR TEMPERATURE (C)										
		21	27	30	32	35	38	41	43	46	49	52
0	TC	68.8	64.4	62.1	60.5	58.2	55.8	53.4	51.8	49.2	46.8	44.0
	kW	14.6	16.5	17.5	18.2	19.3	20.4	21.5	22.3	23.5	24.7	25.9
2	TC	73.7	69.0	66.5	64.9	62.5	60.0	57.4	55.7	52.9	50.2	47.6
	kW	14.8	16.7	17.7	18.4	19.5	20.7	21.8	22.6	23.8	25.1	26.3
4	TC	78.7	73.8	71.1	69.3	66.7	64.1	61.5	59.6	56.9	54.0	51.0
	kW	15.1	17.0	18.0	18.7	19.8	21.0	22.1	23.0	24.2	25.4	26.7
6	TC	83.8	78.4	75.7	73.9	71.2	68.4	65.5	63.6	60.4	57.4	54.3
	kW	15.3	17.3	18.3	19.0	20.1	21.3	22.4	23.3	24.5	25.8	27.1
8	TC	89.1	83.3	80.4	78.4	75.6	72.6	69.6	67.5	64.1	61.1	57.7
	kW	15.6	17.5	18.6	19.3	20.4	21.5	22.7	23.6	24.8	26.1	27.4
10	TC	94.2	88.2	85.1	83.1	80.0	76.6	73.4	71.2	68.1	64.4	61.2
	kW	15.9	17.8	18.8	19.6	20.7	21.8	23.0	23.8	25.1	26.4	27.7

## CIRCUIT B

SST (C)*		CONDENSER ENTERING-AIR TEMPERATURE (C)										
		21	27	30	32	35	38	41	43	46	49	52
0	TC	59.6	56.0	54.2	52.9	51.0	49.1	47.2	45.9	43.8	41.7	39.7
	kW	11.8	13.5	14.4	15.0	16.0	17.0	18.1	18.9	20.0	21.2	22.5
2	TC	63.7	59.9	57.9	56.6	54.6	52.6	50.5	49.1	46.9	44.7	42.5
	kW	12.0	13.7	14.6	15.2	16.2	17.2	18.3	19.1	20.2	21.4	22.7
4	TC	67.9	63.9	61.8	60.3	58.2	56.1	53.9	52.4	50.1	47.7	45.3
	kW	12.1	13.8	14.7	15.4	16.3	17.4	18.5	19.2	20.4	21.6	22.8
6	TC	72.4	67.9	65.6	64.1	61.9	59.6	57.3	55.7	53.3	50.6	48.0
	kW	12.3	14.0	14.9	15.5	16.5	17.6	18.7	19.4	20.6	21.8	23.0
8	TC	76.8	72.0	69.6	67.9	65.6	63.2	60.7	59.0	56.2	53.7	51.0
	kW	12.5	14.2	15.1	15.7	16.7	17.7	18.8	19.6	20.7	21.9	23.2
10	TC	81.2	76.1	73.6	71.9	69.4	66.5	63.8	62.0	59.5	56.4	53.7
	kW	12.7	14.4	15.3	15.9	16.9	17.9	19.0	19.7	20.9	22.1	23.4

### LEGEND

- kW** — Compressor Power
- SST** — Saturated Suction Temperature Entering Condensing Unit
- TC** — Gross Cooling Capacity (kW)

### NOTES:

1. Ratings are based on 8.3 C superheat and use of R-410A refrigerant.
2. Ratings include suction line losses due to an accumulator.
3. Refer to Commercial Split Builder program for more detailed information.

\* 38AP units are not designed for refrigeration duty. Unit operational range should be reviewed to ensure that operation at full and part load conditions with saturated suction temperatures at or below 0° C are avoided. Operation below 0° C SST may result in ice build-up on evaporator coil, resulting in liquid flood-back and possible compressor failure.



### 38APD050 CONDENSING UNIT CIRCUIT RATINGS, 60 Hz SI CIRCUIT A

SST (C)*		CONDENSER ENTERING-AIR TEMPERATURE (C)										
		21	27	30	32	35	38	41	43	46	49	52
0	TC	77.7	72.9	70.3	68.6	66.0	63.3	60.7	58.9	55.9	53.1	50.1
	kW	17.2	19.4	20.6	21.4	22.7	24.0	25.4	26.3	27.7	29.1	30.5
2	TC	83.2	78.1	75.3	73.5	70.8	67.9	65.0	63.1	60.3	57.3	54.2
	kW	17.4	19.6	20.8	21.7	22.9	24.3	25.6	26.6	28.0	29.5	30.9
4	TC	88.9	83.3	80.4	78.5	75.7	72.7	69.5	67.7	64.3	61.1	57.8
	kW	17.6	19.9	21.0	21.9	23.2	24.5	25.9	26.9	28.3	29.8	31.3
6	TC	94.7	88.8	85.7	83.7	80.6	77.5	74.1	71.9	68.6	65.5	61.7
	kW	17.8	20.1	21.3	22.1	23.4	24.8	26.2	27.1	28.6	30.1	31.6
8	TC	100.5	94.1	91.0	88.8	85.6	82.3	78.7	76.6	73.1	69.5	66.0
	kW	18.1	20.3	21.5	22.4	23.7	25.0	26.4	27.4	28.9	30.4	33.0
10	TC	106.4	99.6	96.4	94.0	90.6	86.8	83.4	80.8	77.3	73.3	70.0
	kW	18.3	20.5	21.8	22.6	23.9	25.2	26.7	27.6	29.1	30.6	34.0

### CIRCUIT B

SST (C)*		CONDENSER ENTERING-AIR TEMPERATURE (C)										
		21	27	30	32	35	38	41	43	46	49	52
0	TC	86.8	81.5	78.9	77.1	74.4	71.5	68.8	66.9	64.0	61.0	57.9
	kW	20.2	22.4	23.6	24.5	25.8	27.1	28.6	29.6	31.1	32.7	34.3
2	TC	92.6	87.0	84.2	82.2	79.4	76.3	73.2	71.3	68.3	65.1	61.8
	kW	20.7	22.9	24.1	25.0	26.3	27.6	29.0	30.0	31.6	33.1	34.8
4	TC	98.6	92.6	89.5	87.3	84.4	81.3	78.0	75.9	72.3	69.1	65.3
	kW	21.2	23.4	24.6	25.4	26.7	28.1	29.5	30.5	32.0	33.6	35.2
6	TC	104.5	98.1	94.9	92.7	89.5	86.1	82.5	80.1	76.6	73.2	69.4
	kW	21.7	23.9	25.1	25.9	27.2	28.6	30.0	31.0	32.5	34.1	35.7
8	TC	110.7	103.7	100.4	98.1	94.6	90.7	87.1	84.9	81.1	77.2	—
	kW	22.3	24.5	25.7	26.5	27.8	29.1	30.5	31.5	33.0	34.6	—
10	TC	116.9	109.3	105.7	103.4	99.3	95.5	92.0	89.0	85.0	81.3	—
	kW	22.8	25.0	26.2	27.0	28.3	29.6	31.1	32.0	33.5	35.1	—

#### LEGEND

**kW** — Compressor Power  
**SST** — Saturated Suction Temperature Entering Condensing Unit  
**TC** — Gross Cooling Capacity (kW)

#### NOTES:

1. Ratings are based on 8.3 C superheat and use of R-410A refrigerant.
2. Ratings include suction line losses due to an accumulator.
3. Refer to Commercial Split Builder program for more detailed information.

\* 38AP units are not designed for refrigeration duty. Unit operational range should be reviewed to ensure that operation at full and part load conditions with saturated suction temperatures at or below 0° C are avoided. Operation below 0° C SST may result in ice build-up on evaporator coil, resulting in liquid flood-back and possible compressor failure.

# Performance data (cont)



## 38APD060 CONDENSING UNIT CIRCUIT RATINGS, 60 Hz SI CIRCUIT A

SST (C)*		CONDENSER ENTERING-AIR TEMPERATURE (C)										
		21	27	30	32	35	38	41	43	46	49	52
0	TC	87.2	81.8	80.2	77.8	75.8	72.1	70.3	68.6	65.2	63.2	60.0
	kW	18.6	20.6	21.8	22.6	23.9	25.1	26.5	27.6	29.0	30.7	32.0
2	TC	92.0	87.5	85.6	82.9	80.9	76.8	75.1	72.9	70.1	67.2	64.3
	kW	19.0	21.0	22.2	23.0	24.2	25.5	26.9	27.9	29.3	30.8	32.5
4	TC	98.9	93.3	91.1	88.1	86.0	83.0	79.3	77.9	74.8	71.0	68.4
	kW	19.4	21.5	22.6	23.4	24.7	26.0	27.3	28.3	29.8	31.4	32.9
6	TC	104.9	95.0	95.5	93.8	91.2	88.4	83.9	82.2	79.2	75.9	72.7
	kW	19.8	21.8	23.0	23.8	25.1	26.4	27.8	28.7	30.1	31.6	33.3
8	TC	110.9	99.4	98.9	98.8	96.5	92.0	89.8	86.1	83.9	79.8	76.9
	kW	20.3	22.2	23.4	24.3	25.6	26.8	28.2	29.2	30.6	32.2	33.7
10	TC	117.3	105.6	103.6	103.1	102.2	97.0	95.2	90.9	88.7	83.8	81.4
	kW	20.8	22.7	23.9	24.7	26.1	27.3	28.8	29.6	31.1	32.7	34.2

## CIRCUIT B

SST (C)*		CONDENSER ENTERING-AIR TEMPERATURE (C)										
		21	27	30	32	35	38	41	43	46	49	52
0	TC	102.0	95.6	93.7	90.8	88.6	84.6	82.2	79.3	76.9	72.4	70.0
	kW	23.5	26.1	27.6	28.5	30.2	31.8	33.5	34.7	36.7	38.4	40.0
2	TC	108.0	102.2	100.3	96.9	94.7	90.3	87.9	85.0	82.1	78.6	75.1
	kW	25.0	26.7	28.2	29.1	30.7	32.3	34.0	35.2	37.0	38.8	40.8
4	TC	110.5	108.9	106.8	103.2	100.9	96.2	93.6	90.4	87.7	82.8	80.1
	kW	24.5	27.2	28.8	29.7	31.3	32.9	34.6	35.8	37.6	39.6	41.4
6	TC	118.6	115.8	113.6	109.9	107.3	102.0	99.5	96.5	93.1	89.1	85.3
	kW	25.1	27.9	29.4	30.3	31.9	33.5	35.2	36.3	38.1	39.9	41.9
8	TC	130.5	122.8	120.3	116.1	113.7	108.2	105.7	101.2	98.8	93.6	90.3
	kW	25.9	28.5	30.0	30.9	32.5	34.1	35.8	37.0	38.8	40.8	42.6
10	TC	137.8	129.5	127.2	122.3	120.4	114.3	112.2	106.9	104.5	97.8	—
	kW	26.6	29.2	30.6	31.6	33.2	34.8	36.6	37.6	39.4	41.3	—

### LEGEND

**kW** — Compressor Power  
**SST** — Saturated Suction Temperature Entering Condensing Unit  
**TC** — Gross Cooling Capacity (kW)

### NOTES:

1. Ratings are based on 8.3 C superheat and use of R-410A refrigerant.
2. Ratings include suction line losses due to an accumulator.
3. Refer to Commercial Split Builder program for more detailed information.

\* 38AP units are not designed for refrigeration duty. Unit operational range should be reviewed to ensure that operation at full and part load conditions with saturated suction temperatures at or below 0° C are avoided. Operation below 0° C SST may result in ice build-up on evaporator coil, resulting in liquid flood-back and possible compressor failure.

**38APD070 CONDENSING UNIT CIRCUIT RATINGS, 60 Hz SI**  
**CIRCUIT A**

SST (C)*		CONDENSER ENTERING-AIR TEMPERATURE (C)										
		21	27	30	32	35	38	41	43	46	49	52
0	TC	101.9	96.0	93.0	91.0	88.0	84.9	81.8	79.7	76.4	73.2	69.8
	kW	23.5	26.1	27.6	28.6	30.2	31.9	33.6	34.9	36.8	38.8	40.9
2	TC	109.1	102.9	99.7	97.5	94.3	91.0	87.7	85.4	82.0	78.4	74.9
	kW	24.0	26.7	28.1	29.1	30.7	32.5	34.2	35.4	37.3	39.3	41.4
4	TC	116.6	109.9	106.5	104.2	100.8	97.3	93.7	91.3	87.7	84.0	80.1
	kW	24.5	27.2	28.7	29.7	31.3	33.0	34.7	36.0	37.9	39.9	41.9
6	TC	124.3	117.2	113.6	111.2	107.5	103.8	100.0	97.5	93.6	89.5	85.4
	kW	25.1	27.8	29.2	30.2	31.8	33.5	35.3	36.5	38.4	40.4	42.5
8	TC	132.2	124.6	120.8	118.3	114.4	110.4	106.4	103.7	99.5	95.2	—
	kW	25.7	28.4	29.8	30.8	32.4	34.1	35.9	37.1	39.0	41.0	—
10	TC	140.2	132.2	128.2	125.5	121.3	117.1	112.8	109.9	105.5	100.9	—
	kW	26.4	29.0	30.5	31.5	33.0	34.7	36.5	37.7	39.6	41.5	—

**CIRCUIT B**

SST (C)*		CONDENSER ENTERING-AIR TEMPERATURE (C)										
		21	27	30	32	35	38	41	43	46	49	52
0	TC	116.3	108.8	104.9	102.3	98.4	94.4	90.4	87.6	83.4	79.2	74.8
	kW	26.2	29.4	31.1	32.3	34.1	35.9	37.9	39.2	41.2	43.2	45.3
2	TC	124.3	116.4	112.3	109.6	105.5	101.3	97.0	94.1	89.7	85.2	80.6
	kW	26.7	29.9	31.6	32.8	34.7	36.6	38.5	39.9	41.9	44.0	46.1
4	TC	132.6	124.2	119.9	117.0	112.7	108.3	103.8	100.8	96.1	91.4	86.5
	kW	27.2	30.5	32.2	33.4	35.2	37.2	39.2	40.5	42.6	44.8	46.9
6	TC	141.0	132.1	127.6	124.6	120.0	115.3	110.6	107.4	102.6	97.6	92.4
	kW	27.8	31.0	32.8	34.0	35.8	37.8	39.8	41.2	43.3	45.5	47.7
8	TC	149.6	140.2	135.4	132.2	127.4	122.5	117.5	114.2	109.0	103.8	97.5
	kW	28.4	31.6	33.4	34.6	36.5	38.4	40.5	41.9	44.0	46.2	48.5
10	TC	158.3	148.3	143.3	139.9	134.8	129.7	124.5	120.9	115.5	110.0	—
	kW	29.0	32.2	34.0	35.2	37.1	39.1	41.1	42.5	44.7	46.9	—

**LEGEND**

**kW** — Compressor Power  
**SST** — Saturated Suction Temperature Entering Condensing Unit  
**TC** — Gross Cooling Capacity (kW)

**NOTES:**

1. Ratings are based on 8.3 C superheat and use of R-410A refrigerant.
2. Ratings include suction line losses due to an accumulator.
3. Refer to Commercial Split Builder program for more detailed information.

\* 38AP units are not designed for refrigeration duty. Unit operational range should be reviewed to ensure that operation at full and part load conditions with saturated suction temperatures at or below 0° C are avoided. Operation below 0° C SST may result in ice build-up on evaporator coil, resulting in liquid flood-back and possible compressor failure.

# Performance data (cont)



## 38APD080 CONDENSING UNIT CIRCUIT RATINGS, 60 Hz SI CIRCUIT A

SST (C)*		CONDENSER ENTERING-AIR TEMPERATURE (C)										
		21	27	30	32	35	38	41	43	46	49	52
0	TC	102.6	96.5	93.5	92.1	88.2	84.9	81.8	80.4	76.3	72.8	70.7
	kW	22.8	25.3	26.7	27.7	29.1	30.7	32.4	33.5	35.3	37.2	39.0
2	TC	109.5	103.1	99.8	98.3	93.9	90.6	87.3	85.8	82.8	77.6	75.5
	kW	23.3	25.8	27.2	28.2	29.6	31.2	32.9	34.0	35.8	37.6	39.4
4	TC	117.0	109.8	107.2	104.5	101.4	96.2	94.2	90.4	88.0	82.7	80.3
	kW	23.9	26.4	27.8	28.7	30.2	31.7	33.4	34.5	36.3	38.2	39.9
6	TC	124.3	116.6	114.0	109.7	107.6	102.0	100.0	95.5	93.4	87.5	85.1
	kW	24.5	27.0	28.4	29.2	30.8	32.3	34.0	35.0	36.8	38.7	40.5
8	TC	131.6	123.3	120.3	117.2	113.7	109.8	103.7	102.3	98.6	92.4	90.2
	kW	25.1	27.6	29.0	29.9	31.4	32.9	34.5	35.6	37.4	39.2	41.1
10	TC	138.6	130.3	127.4	124.2	120.4	113.7	111.0	108.1	103.9	97.6	94.7
	kW	25.7	28.2	29.7	30.6	32.1	33.4	35.1	36.3	38.0	39.8	41.6

## CIRCUIT B

SST (C)*		CONDENSER ENTERING-AIR TEMPERATURE (C)										
		21	27	30	32	35	38	41	43	46	49	52
0	TC	153.7	145.4	140.9	138.8	132.9	128.1	123.3	121.2	114.9	109.7	106.4
	kW	33.5	37.6	39.7	41.2	43.6	46.1	48.6	50.4	53.2	56.1	58.8
2	TC	164.7	155.2	150.4	148.0	141.7	136.7	131.5	129.3	124.6	117.1	113.7
	kW	34.2	38.2	40.3	41.8	44.2	46.7	49.2	51.0	53.7	56.7	59.4
4	TC	175.6	164.9	161.0	157.0	152.4	145.1	141.7	136.2	132.5	124.9	120.9
	kW	34.9	38.8	41.0	42.5	44.8	47.3	49.8	51.6	54.3	57.3	60.0
6	TC	186.0	174.6	170.7	166.5	161.3	153.4	149.9	143.7	140.2	131.9	127.9
	kW	35.6	39.4	41.7	43.2	45.5	47.9	50.5	52.2	54.9	57.9	60.7
8	TC	196.1	183.9	179.4	174.9	169.7	164.0	157.8	153.0	147.4	141.5	132.3
	kW	36.3	40.1	42.4	43.8	46.2	48.6	51.1	52.8	55.6	58.5	61.4
10	TC	205.6	193.0	188.9	184.2	178.6	169.1	165.0	160.8	154.5	144.3	141.0
	kW	36.8	40.8	43.2	44.6	47.0	49.1	51.7	53.6	56.3	59.1	61.9

### LEGEND

- kW — Compressor Power
- SST — Saturated Suction Temperature Entering Condensing Unit
- TC — Gross Cooling Capacity (kW)

### NOTES:

1. Ratings are based on 8.3 C superheat and use of R-410A refrigerant.
2. Ratings include suction line losses due to an accumulator.
3. Refer to Commercial Split Builder program for more detailed information.

\* 38AP units are not designed for refrigeration duty. Unit operational range should be reviewed to ensure that operation at full and part load conditions with saturated suction temperatures at or below 0° C are avoided. Operation below 0° C SST may result in ice build-up on evaporator coil, resulting in liquid flood-back and possible compressor failure.

**38APD090 CONDENSING UNIT CIRCUIT RATINGS, 60 Hz SI**  
**CIRCUIT A**

SST (C)*		CONDENSER ENTERING-AIR TEMPERATURE (C)										
		21	27	30	32	35	38	41	43	46	49	52
0	TC	133.1	124.7	120.6	119.0	115.2	109.7	105.5	103.7	98.5	93.3	90.2
	kW	27.3	30.7	32.6	34.0	36.0	38.2	40.5	42.0	44.5	46.8	49.1
2	TC	141.7	132.8	129.9	125.8	121.3	118.4	112.5	110.3	104.7	101.2	94.9
	kW	27.7	31.2	33.1	34.4	36.4	38.6	40.8	42.3	44.8	47.1	49.7
4	TC	151.3	141.3	137.9	133.4	130.3	124.1	120.9	115.4	112.3	105.7	102.2
	kW	28.3	31.6	33.6	34.8	36.9	39.0	41.2	42.7	45.0	47.5	49.9
6	TC	160.3	149.5	145.9	142.1	137.7	130.7	127.6	121.7	118.6	111.5	108.0
	kW	28.9	32.2	34.1	35.3	37.4	39.4	41.6	43.1	45.4	47.9	50.3
8	TC	169.2	158.0	154.0	147.9	144.7	139.6	131.4	129.7	124.7	116.1	113.1
	kW	29.5	32.8	34.7	35.7	37.9	39.9	42.0	43.5	45.8	48.2	50.6
10	TC	177.3	165.1	161.1	157.3	152.5	143.0	139.3	134.9	129.8	125.0	114.4
	kW	30.1	33.2	35.3	36.5	38.5	40.2	42.5	43.9	46.2	48.7	51.0

**CIRCUIT B**

SST (C)*		CONDENSER ENTERING-AIR TEMPERATURE (C)										
		21	27	30	32	35	38	41	43	46	49	52
0	TC	153.0	145.0	140.1	138.2	133.8	127.5	122.7	120.7	114.8	109.2	105.9
	kW	33.8	37.9	40.1	41.6	43.9	46.5	49.1	50.9	53.8	56.6	59.4
2	TC	164.1	154.4	151.1	146.3	141.2	137.9	131.2	128.8	124.2	117.1	113.3
	kW	34.5	38.5	40.7	42.2	44.6	47.1	49.7	51.4	54.3	57.3	60.0
4	TC	174.4	164.3	160.6	156.7	152.0	144.5	141.3	135.3	131.7	124.4	120.5
	kW	35.2	39.2	41.4	42.9	45.3	47.7	50.3	52.1	54.8	57.8	60.6
6	TC	185.6	173.8	169.9	165.6	160.9	153.2	149.5	143.1	139.4	131.5	127.6
	kW	35.9	39.8	42.1	43.5	45.9	48.3	51.0	52.7	55.4	58.4	61.3
8	TC	195.7	183.6	179.5	175.1	169.4	163.7	154.8	152.7	147.0	137.5	133.9
	kW	36.6	40.5	42.8	44.3	46.6	49.1	51.5	53.4	56.1	59.0	61.8
10	TC	204.0	192.6	188.1	183.9	177.6	171.7	162.7	159.1	153.4	147.4	137.8
	kW	37.1	41.2	43.6	45.1	47.3	49.8	52.2	53.9	56.7	59.6	62.6

**LEGEND**

- kW** — Compressor Power
- SST** — Saturated Suction Temperature Entering Condensing Unit
- TC** — Gross Cooling Capacity (kW)

**NOTES:**

1. Ratings are based on 8.3 C superheat and use of R-410A refrigerant.
2. Ratings include suction line losses due to an accumulator.
3. Refer to Commercial Split Builder program for more detailed information.

\* 38AP units are not designed for refrigeration duty. Unit operational range should be reviewed to ensure that operation at full and part load conditions with saturated suction temperatures at or below 0° C are avoided. Operation below 0° C SST may result in ice build-up on evaporator coil, resulting in liquid flood-back and possible compressor failure.

# Performance data (cont)



## 38APD100 CONDENSING UNIT CIRCUIT RATINGS, 60 Hz SI CIRCUIT A

SST (C)*		CONDENSER ENTERING-AIR TEMPERATURE (C)										
		21	27	30	32	35	38	41	43	46	49	52
0	TC	159.4	149.4	145.3	141.7	137.4	132.2	127.9	124.0	119.7	113.8	109.6
	kW	32.7	38.7	40.6	42.1	44.7	47.1	49.5	51.5	54.1	57.3	60.0
2	TC	170.1	160.1	155.6	151.0	147.3	141.5	137.0	132.8	128.4	121.8	117.7
	kW	33.4	39.4	41.6	43.0	45.4	47.9	50.3	52.3	54.8	58.1	60.7
4	TC	179.2	169.2	166.5	161.7	157.7	151.1	146.6	142.7	137.4	131.7	125.9
	kW	34.1	40.1	42.4	43.8	46.2	48.7	51.0	52.8	55.4	58.2	61.1
6	TC	191.4	181.4	177.6	172.3	168.1	162.2	156.4	152.0	146.6	140.4	134.3
	kW	35.0	41.0	43.2	44.7	47.0	49.4	51.9	53.6	56.2	59.1	62.0
8	TC	203.5	193.5	188.8	184.2	178.5	172.4	166.3	161.8	155.8	149.3	142.9
	kW	35.9	41.9	44.1	45.5	47.7	50.1	52.6	54.1	57.1	59.9	62.9
10	TC	213.0	203.0	199.3	195.1	189.6	182.8	176.4	171.3	165.0	158.2	151.5
	kW	36.0	42.0	45.0	46.4	48.8	51.1	53.7	55.3	57.9	60.6	63.8

## CIRCUIT B

SST (C)*		CONDENSER ENTERING-AIR TEMPERATURE (C)										
		21	27	30	32	35	38	41	43	46	49	52
0	TC	155.9	145.9	141.9	138.4	134.1	129.0	124.8	121.0	116.9	111.1	107.0
	kW	32.3	38.3	40.3	41.8	44.3	46.8	49.1	51.1	53.7	56.9	59.6
2	TC	166.3	156.3	152.0	147.4	143.9	138.2	133.8	129.6	125.5	119.0	114.9
	kW	33.1	39.1	41.3	42.7	45.1	47.5	49.9	51.9	54.4	57.7	60.3
4	TC	173.9	163.9	162.7	158.0	154.1	147.7	143.3	139.4	134.3	128.8	123.0
	kW	33.7	39.7	42.1	43.5	45.8	48.3	50.6	52.4	55.0	57.9	60.7
6	TC	187.2	177.2	173.6	168.4	164.4	158.7	153.0	148.7	143.3	137.4	131.5
	kW	34.6	40.6	42.9	44.3	46.7	49.0	51.5	53.2	55.8	58.7	61.6
8	TC	199.3	189.3	184.8	180.3	174.8	168.7	162.8	158.4	152.6	146.3	140.0
	kW	35.5	41.5	43.8	45.2	47.4	49.7	52.2	53.7	56.7	59.5	62.5
10	TC	211.0	201.0	195.0	190.9	185.6	179.1	172.8	167.8	161.7	155.1	148.6
	kW	35.7	41.7	44.6	46.0	48.5	50.8	53.3	54.9	57.6	60.2	63.4

### LEGEND

- kW — Compressor Power
- SST — Saturated Suction Temperature Entering Condensing Unit
- TC — Gross Cooling Capacity (kW)

### NOTES:

1. Ratings are based on 8.3 C superheat and use of R-410A refrigerant.
2. Ratings include suction line losses due to an accumulator.
3. Refer to Commercial Split Builder program for more detailed information.

\* 38AP units are not designed for refrigeration duty. Unit operational range should be reviewed to ensure that operation at full and part load conditions with saturated suction temperatures at or below 0° C are avoided. Operation below 0° C SST may result in ice build-up on evaporator coil, resulting in liquid flood-back and possible compressor failure.



**38APD115 CONDENSING UNIT CIRCUIT RATINGS, 60 Hz SI  
CIRCUIT A**

SST (C)*		CONDENSER ENTERING-AIR TEMPERATURE (C)										
		21	27	30	32	35	38	41	43	46	49	52
0	TC	155.9	146.7	142.2	139.8	134.4	129.7	124.8	122.4	116.9	110.9	106.0
	kW	34.7	38.8	41.1	42.7	45.1	47.6	50.3	52.1	55.1	57.9	61.0
2	TC	164.8	157.1	152.2	149.8	144.1	139.0	133.7	131.4	125.3	119.7	114.1
	kW	35.2	39.5	41.7	43.3	45.7	48.3	50.9	52.7	55.7	58.6	61.7
4	TC	177.2	167.9	162.4	160.2	153.5	148.4	143.0	140.6	133.6	127.9	121.8
	kW	35.9	40.1	42.3	43.9	46.3	48.9	51.5	53.3	56.2	59.2	62.3
6	TC	189.7	178.7	173.1	170.6	163.8	159.9	152.0	149.7	142.2	138.3	129.5
	kW	36.7	40.8	43.0	44.6	47.0	49.5	52.2	53.9	56.8	59.6	62.8
8	TC	201.0	189.4	185.6	181.0	175.7	169.9	162.0	159.1	153.2	144.5	140.2
	kW	37.4	41.5	43.8	45.2	47.7	50.2	52.8	54.6	57.4	60.4	63.3
10	TC	213.1	200.7	195.9	191.3	185.7	179.6	171.0	167.7	161.7	152.1	147.8
	kW	38.2	42.2	44.5	45.9	48.4	50.9	53.4	55.2	58.0	61.0	63.8

**CIRCUIT B**

SST (C)*		CONDENSER ENTERING-AIR TEMPERATURE (C)										
		21	27	30	32	35	38	41	43	46	49	52
0	TC	198.4	185.0	179.2	176.0	168.7	162.1	155.6	152.7	145.5	138.1	131.4
	kW	43.9	49.2	52.1	54.1	57.2	60.5	64.0	66.3	70.2	74.0	78.1
2	TC	209.4	198.8	192.3	189.1	181.0	174.2	167.1	164.3	156.3	148.6	141.6
	kW	44.4	50.0	52.9	55.0	58.1	61.4	64.8	67.2	71.1	74.9	78.9
4	TC	226.0	213.2	205.6	202.6	193.5	186.5	179.2	176.1	166.8	159.2	151.5
	kW	45.4	50.9	53.7	55.8	58.9	62.2	65.7	68.0	71.8	75.7	79.7
6	TC	243.1	227.5	219.7	216.3	206.9	201.7	191.7	188.0	177.8	172.9	161.3
	kW	46.4	51.7	54.6	56.7	59.8	63.1	66.6	68.8	72.6	76.2	80.5
8	TC	258.1	241.8	236.6	228.7	223.0	211.5	206.6	197.5	192.6	180.8	175.5
	kW	47.3	52.6	55.7	57.5	60.8	64.0	67.4	69.8	73.4	77.4	81.1
10	TC	275.0	257.1	250.7	244.2	236.6	224.1	219.1	209.8	204.1	191.2	185.8
	kW	48.4	53.6	56.6	58.5	61.7	64.8	68.4	70.7	74.3	78.1	81.9

**LEGEND**

- kW** — Compressor Power  
**SST** — Saturated Suction Temperature Entering Condensing Unit  
**TC** — Gross Cooling Capacity (kW)

**NOTES:**

1. Ratings are based on 8.3 C superheat and use of R-410A refrigerant.
2. Ratings include suction line losses due to an accumulator.
3. Refer to Commercial Split Builder program for more detailed information.

\* 38AP units are not designed for refrigeration duty. Unit operational range should be reviewed to ensure that operation at full and part load conditions with saturated suction temperatures at or below 0° C are avoided. Operation below 0° C SST may result in ice build-up on evaporator coil, resulting in liquid flood-back and possible compressor failure.

# Performance data (cont)



## 38APD130 CONDENSING UNIT CIRCUIT RATINGS, 60 Hz SI CIRCUIT A

SST (C)*		CONDENSER ENTERING-AIR TEMPERATURE (C)										
		21	27	30	32	35	38	41	43	46	49	52
0	TC	155.6	146.8	142.2	139.8	134.3	129.7	124.8	121.7	116.1	111.8	106.0
	kW	34.7	38.8	41.1	42.7	45.1	47.6	50.3	52.1	55.0	57.9	61.0
2	TC	164.9	157.0	152.2	149.8	144.0	138.9	133.7	131.4	125.0	119.7	114.1
	kW	35.2	39.5	41.7	43.3	45.7	48.2	50.9	52.7	55.6	58.6	61.6
4	TC	176.7	167.6	162.7	160.2	153.8	148.3	142.9	140.5	133.6	127.8	121.9
	kW	35.9	40.1	42.4	43.9	46.3	48.9	51.5	53.3	56.2	59.2	62.3
6	TC	189.7	178.7	173.2	170.6	163.6	158.0	152.2	149.7	142.3	136.0	129.6
	kW	36.7	40.8	43.0	44.6	47.0	49.5	52.1	53.9	56.8	59.8	62.8
8	TC	201.0	189.7	183.9	181.0	173.5	167.7	161.3	158.7	150.8	146.6	137.4
	kW	37.4	41.5	43.7	45.3	47.6	50.1	52.8	54.5	57.4	60.2	63.4
10	TC	212.7	200.6	195.9	191.2	185.6	179.5	171.0	167.7	162.0	152.6	147.8
	kW	38.1	42.2	44.5	45.9	48.4	50.9	53.4	55.2	58.1	61.0	63.8

## CIRCUIT B

SST (C)*		CONDENSER ENTERING-AIR TEMPERATURE (C)										
		21	27	30	32	35	38	41	43	46	49	52
0	TC	247.3	232.2	225.1	221.5	212.8	204.9	197.1	192.1	183.9	176.1	167.7
	kW	56.0	62.2	65.5	67.9	71.4	75.2	79.2	82.0	86.2	90.7	95.3
2	TC	260.7	248.9	241.2	237.5	227.9	219.7	211.3	207.8	197.3	188.8	180.1
	kW	56.9	63.5	66.8	69.2	72.7	76.5	80.5	83.2	87.5	91.9	96.6
4	TC	281.7	266.1	258.1	254.1	243.7	234.7	226.0	222.2	211.1	201.8	192.4
	kW	58.4	64.8	68.1	70.6	74.1	77.8	81.8	84.5	88.8	93.2	97.8
6	TC	302.7	284.4	275.0	270.9	259.2	250.1	241.0	237.0	225.0	215.0	204.8
	kW	60.0	66.2	69.5	71.9	75.4	79.2	83.1	85.9	90.1	94.5	99.1
8	TC	321.3	302.8	292.9	288.3	275.6	266.5	255.7	252.0	238.9	232.4	217.0
	kW	61.3	67.6	70.9	73.4	76.7	80.6	84.5	87.3	91.5	95.7	100.5
10	TC	341.1	321.2	313.5	305.6	296.5	281.3	275.3	264.1	257.8	242.3	234.9
	kW	62.8	69.0	72.7	74.8	78.5	81.9	86.2	88.7	93.1	97.3	101.7

### LEGEND

**kW** — Compressor Power  
**SST** — Saturated Suction Temperature Entering Condensing Unit  
**TC** — Gross Cooling Capacity (kW)

### NOTES:

1. Ratings are based on 8.3 C superheat and use of R-410A refrigerant.
2. Ratings include suction line losses due to an accumulator.
3. Refer to Commercial Split Builder program for more detailed information.

\* 38AP units are not designed for refrigeration duty. Unit operational range should be reviewed to ensure that operation at full and part load conditions with saturated suction temperatures at or below 0° C are avoided. Operation below 0° C SST may result in ice build-up on evaporator coil, resulting in liquid flood-back and possible compressor failure.

### 38APD,APS025 CONDENSING UNIT RATINGS, 50 Hz ENGLISH

SST (F)*		CONDENSER ENTERING-AIR TEMPERATURE (F)										
		70	80	85	90	95	100	105	110	115	120	125
30	TC	213.5	201.0	194.6	188.1	181.5	174.8	168.0	161.0	153.9	146.7	139.4
	kW	13.6	15.2	16.1	17.0	17.9	18.8	19.8	20.8	21.9	22.9	24.0
35	TC	235.4	221.9	215.0	207.9	200.8	193.6	186.3	178.8	171.2	163.5	155.5
	kW	13.9	15.5	16.3	17.2	18.1	19.1	20.1	21.1	22.2	23.2	24.3
40	TC	258.1	243.4	235.8	228.1	220.5	212.8	204.9	196.9	188.7	180.3	171.7
	kW	14.1	15.7	16.5	17.4	18.3	19.3	20.3	21.4	22.4	23.5	24.7
45	TC	281.1	264.8	256.3	248.1	239.8	231.5	222.9	214.2	205.4	196.4	187.1
	kW	14.3	15.9	16.7	17.6	18.6	19.5	20.5	21.6	22.7	23.8	24.9
50	TC	303.3	285.0	275.7	266.9	258.0	248.9	239.6	230.2	220.7	210.9	201.0
	kW	14.6	16.1	17.0	17.9	18.8	19.8	20.8	21.8	22.9	24.0	25.2

### 38APD,APS027 CONDENSING UNIT RATINGS, 50 Hz ENGLISH

SST (F)*		CONDENSER ENTERING-AIR TEMPERATURE (F)										
		70	80	85	90	95	100	105	110	115	120	125
30	TC	240.5	227.4	220.7	214.0	207.2	200.3	193.4	186.3	179.1	171.8	164.4
	kW	15.2	16.8	17.7	18.6	19.6	20.6	21.7	22.8	24.0	25.2	26.5
35	TC	263.7	249.3	241.9	234.5	227.1	219.7	212.1	204.4	196.6	188.6	180.4
	kW	15.6	17.2	18.1	19.0	20.0	21.0	22.1	23.2	24.3	25.6	26.8
40	TC	287.3	271.3	263.1	255.1	247.1	239.0	230.9	222.5	214.0	205.3	196.3
	kW	16.1	17.7	18.5	19.4	20.4	21.4	22.5	23.6	24.7	25.9	27.2
45	TC	310.8	293.0	284.0	275.4	266.7	257.9	249.0	239.9	230.7	221.4	211.8
	kW	16.6	18.1	19.0	19.9	20.8	21.8	22.9	24.0	25.1	26.3	27.6
50	TC	333.7	313.8	304.5	295.1	285.6	276.0	266.3	256.5	246.5	236.4	226.0
	kW	17.1	18.6	19.5	20.4	21.3	22.3	23.3	24.4	25.6	26.7	28.0

### 38APD,APS030 CONDENSING UNIT RATINGS, 50 Hz ENGLISH

SST (F)*		CONDENSER ENTERING-AIR TEMPERATURE (F)										
		70	80	85	90	95	100	105	110	115	120	125
30	TC	279.7	264.9	257.4	249.9	242.3	234.6	226.8	218.8	210.7	202.5	194.1
	kW	18.2	20.2	21.3	22.4	23.6	24.9	26.2	27.6	29.1	30.6	32.2
35	TC	306.0	290.0	281.8	273.8	265.7	257.4	249.0	240.4	231.7	222.7	213.6
	kW	18.7	20.7	21.8	22.9	24.1	25.4	26.7	28.1	29.5	31.1	32.6
40	TC	332.5	315.0	306.3	297.8	289.1	280.3	271.4	262.2	252.8	243.2	233.3
	kW	19.3	21.2	22.3	23.4	24.6	25.9	27.2	28.6	30.0	31.6	33.1
45	TC	358.6	339.6	330.4	321.3	312.0	302.7	293.2	283.5	273.6	263.4	252.8
	kW	19.9	21.8	22.9	24.0	25.2	26.4	27.7	29.1	30.6	32.1	33.6
50	TC	384.2	363.9	354.3	344.6	334.7	324.7	314.6	304.3	293.7	282.8	271.6
	kW	20.5	22.4	23.5	24.6	25.8	27.0	28.3	29.7	31.1	32.6	34.1

### 38APD040 CONDENSING UNIT RATINGS, 50 Hz ENGLISH

SST (F)*		CONDENSER ENTERING-AIR TEMPERATURE (F)										
		70	80	85	90	95	100	105	110	115	120	125
30	TC	349.8	329.6	319.3	308.8	298.0	287.1	276.3	265.0	253.6	241.6	229.8
	kW	21.3	24.0	25.4	26.9	28.5	30.1	31.8	33.5	35.3	37.1	39.0
35	TC	384.9	362.7	351.6	340.1	328.4	316.6	304.6	292.7	280.3	267.2	254.1
	kW	21.7	24.4	25.9	27.4	28.9	30.6	32.3	34.1	35.9	37.7	39.7
40	TC	421.4	397.6	385.0	372.3	359.6	346.7	334.2	321.0	307.8	294.1	278.8
	kW	22.1	24.8	26.3	27.8	29.4	31.1	32.8	34.6	36.4	38.3	40.3
45	TC	459.0	433.0	418.8	405.0	391.1	377.6	363.5	349.3	334.8	319.0	304.6
	kW	22.6	25.3	26.7	28.3	29.9	31.5	33.3	35.1	36.9	38.8	40.8
50	TC	497.2	467.9	453.4	438.6	423.7	408.8	392.0	376.9	361.4	343.9	328.6
	kW	23.1	25.8	27.2	28.8	30.4	32.0	33.7	35.6	37.4	39.3	41.3

#### LEGEND

- kW** — Compressor Power
- SST** — Saturated Suction Temperature Entering Condensing Unit
- TC** — Gross Cooling Capacity (1000 Btuh)

\* 38AP units are not designed for refrigeration duty. Unit operational range should be reviewed to ensure that operation at full and part load conditions with saturated suction temperatures at or below 30 F are avoided. Operation below 30 F SST may result in ice build-up on evaporator coil, resulting in liquid flood-back and possible compressor failure.

#### NOTES:

1. Ratings are based on 15 F superheat and use of R-410A refrigerant.
2. Ratings include suction line losses due to an accumulator.
3. Refer to Commercial Split Builder program for more detailed information.

# Performance data (cont)



## 38APS040 CONDENSING UNIT RATINGS, 50 Hz ENGLISH

SST (F)*		CONDENSER ENTERING-AIR TEMPERATURE (F)										
		70	80	85	90	95	100	105	110	115	120	125
30	TC	352.7	332.4	322.1	311.9	301.6	291.1	280.4	269.7	258.7	248.1	236.8
	kW	21.1	23.4	24.7	26.0	27.4	28.8	30.4	32.0	33.7	35.4	37.3
35	TC	386.2	364.9	353.5	342.3	330.9	319.4	307.7	296.3	284.4	272.5	260.3
	kW	21.7	24.0	25.3	26.6	28.0	29.4	31.0	32.6	34.3	36.0	37.9
40	TC	422.9	399.0	386.5	374.1	361.5	349.0	336.8	324.0	311.1	298.1	284.8
	kW	22.3	24.6	25.9	27.2	28.6	30.1	31.6	33.2	34.9	36.7	38.5
45	TC	461.3	434.3	420.8	407.2	393.6	380.5	366.7	352.8	339.0	324.6	308.7
	kW	23.1	25.4	26.6	27.9	29.3	30.8	32.3	33.9	35.6	37.3	39.2
50	TC	501.1	471.5	456.6	441.8	427.9	412.9	398.0	382.9	367.5	350.4	334.1
	kW	23.8	26.1	27.4	28.7	30.1	31.5	33.0	34.6	36.3	38.0	39.8

## 38APD050 CONDENSING UNIT RATINGS, 50 Hz ENGLISH

SST (F)*		CONDENSER ENTERING-AIR TEMPERATURE (F)										
		70	80	85	90	95	100	105	110	115	120	125
30	TC	449.1	423.5	410.0	397.0	383.5	369.9	356.0	341.5	326.9	312.7	297.3
	kW	29.9	33.3	35.0	36.9	38.9	40.9	43.0	45.2	47.4	49.7	52.1
35	TC	493.0	464.9	450.4	435.9	421.1	406.6	391.4	376.3	360.8	344.1	328.5
	kW	30.7	34.0	35.8	37.7	39.6	41.7	43.8	46.0	48.3	50.6	53.0
40	TC	538.8	507.9	491.9	476.0	460.5	444.3	427.8	411.2	394.1	375.5	357.4
	kW	31.4	34.7	36.5	38.4	40.4	42.4	44.6	46.8	49.1	51.4	53.8
45	TC	585.2	551.8	533.8	516.8	499.2	482.3	464.1	445.7	426.9	407.3	388.0
	kW	32.2	35.5	37.3	39.2	41.2	43.2	45.3	47.6	49.8	52.2	54.6
50	TC	632.6	595.6	576.5	558.7	539.4	520.2	500.1	480.2	459.0	439.1	419.1
	kW	33.0	36.3	38.1	40.0	42.0	44.0	46.1	48.3	50.6	53.0	55.4

## 38APS050 CONDENSING UNIT RATINGS, 50 Hz ENGLISH

SST (F)*		CONDENSER ENTERING-AIR TEMPERATURE (F)										
		70	80	85	90	95	100	105	110	115	120	125
30	TC	422.8	399.6	387.2	375.7	362.8	351.2	337.9	325.9	311.8	293.5	275.2
	kW	27.5	30.6	32.2	33.9	35.6	37.5	39.4	41.5	43.5	45.6	47.7
35	TC	464.2	438.9	426.4	413.4	400.1	385.9	372.0	359.0	344.8	330.3	315.4
	kW	28.2	31.3	32.9	34.6	36.4	38.2	40.2	42.2	44.3	46.5	48.7
40	TC	508.3	480.7	465.9	451.5	437.6	422.9	408.1	392.9	376.3	360.1	345.0
	kW	29.0	32.0	33.6	35.3	37.1	39.0	40.9	42.9	45.0	47.1	49.4
45	TC	552.8	522.6	506.4	490.6	474.5	459.1	442.6	426.2	407.7	389.9	373.3
	kW	29.8	32.8	34.4	36.0	37.8	39.6	41.6	43.6	45.6	47.8	50.0
50	TC	598.1	564.5	546.3	529.7	512.0	494.1	476.1	456.2	437.3	419.7	400.0
	kW	30.6	33.6	35.1	36.8	38.6	40.4	42.3	44.2	46.3	48.4	50.6

## 38APD060 CONDENSING UNIT RATINGS, 50 Hz ENGLISH

SST (F)*		CONDENSER ENTERING-AIR TEMPERATURE (F)										
		70	80	85	90	95	100	105	110	115	120	125
30	TC	516.4	488.0	473.9	459.5	445.0	430.3	415.5	400.8	385.6	370.3	353.9
	kW	33.7	37.2	39.1	41.1	43.3	45.5	47.9	50.3	52.9	55.6	58.4
35	TC	565.7	534.3	519.2	503.5	487.8	471.9	455.7	439.3	422.9	405.9	389.2
	kW	34.7	38.2	40.1	42.1	44.3	46.5	48.9	51.3	53.9	56.6	59.4
40	TC	616.7	582.8	565.8	548.8	531.7	514.5	497.0	479.2	461.4	443.0	424.4
	kW	35.7	39.3	41.2	43.2	45.3	47.6	49.9	52.4	54.9	57.6	60.4
45	TC	669.3	632.4	613.5	595.1	576.5	557.9	538.9	519.9	500.5	480.3	460.6
	kW	36.9	40.4	42.3	44.3	46.4	48.7	51.0	53.5	56.0	58.7	61.5
50	TC	724.5	691.0	657.4	643.2	622.3	602.9	581.2	561.4	539.6	519.1	497.0
	kW	38.2	40.8	43.5	45.6	47.7	49.9	52.2	54.6	57.2	59.8	62.5

### LEGEND

- kW** — Compressor Power
- SST** — Saturated Suction Temperature Entering Condensing Unit
- TC** — Gross Cooling Capacity (1000 Btuh)

### NOTES:

1. Ratings are based on 15 F superheat and use of R-410A refrigerant.
2. Ratings include suction line losses due to an accumulator.
3. Refer to Commercial Split Builder program for more detailed information.

\* 38AP units are not designed for refrigeration duty. Unit operational range should be reviewed to ensure that operation at full and part load conditions with saturated suction temperatures at or below 30 F are avoided. Operation below 30 F SST may result in ice build-up on evaporator coil, resulting in liquid flood-back and possible compressor failure.

### 38APS065 CONDENSING UNIT RATINGS, 50 Hz ENGLISH

SST (F)*		CONDENSER ENTERING-AIR TEMPERATURE (F)										
		70	80	85	90	95	100	105	110	115	120	125
30	TC	532.8	500.8	483.9	467.6	451.0	434.2	417.8	401.0	384.0	366.3	348.2
	kW	35.7	39.5	41.5	43.6	45.8	48.2	50.6	53.1	55.7	58.5	61.3
35	TC	585.6	550.6	532.2	514.5	496.1	477.8	459.5	441.0	422.3	403.1	383.7
	kW	36.8	40.6	42.6	44.8	46.8	49.3	51.7	54.3	56.9	59.6	62.4
40	TC	641.6	602.6	583.2	563.4	543.7	523.8	503.8	483.6	463.0	443.0	420.2
	kW	38.0	41.8	43.9	46.0	47.6	50.5	52.9	55.5	58.1	60.8	63.5
45	TC	700.6	657.7	636.4	614.8	592.8	570.9	549.1	527.6	505.4	483.0	461.0
	kW	39.3	43.1	45.1	47.3	48.1	51.8	54.2	56.7	59.3	62.0	64.8
50	TC	760.9	715.5	691.7	669.6	644.5	621.5	597.9	571.7	549.6	525.5	500.2
	kW	40.7	44.5	46.5	48.7	50.9	53.2	55.6	58.0	60.7	63.3	66.1

### 38APD070 CONDENSING UNIT RATINGS, 50 Hz ENGLISH

SST (F)*		CONDENSER ENTERING-AIR TEMPERATURE (F)										
		70	80	85	90	95	100	105	110	115	120	125
30	TC	622.2	587.5	573.6	554.9	535.5	510.4	495.9	470.9	455.0	428.9	412.6
	kW	41.7	46.6	49.1	51.8	54.6	57.5	60.2	63.4	66.3	69.6	72.5
35	TC	687.3	646.4	631.0	610.5	589.2	568.6	548.1	520.3	503.7	477.7	458.8
	kW	42.8	47.7	50.3	53.0	55.7	58.6	61.7	64.9	67.8	71.2	74.2
40	TC	750.7	707.0	690.1	667.6	645.1	624.3	601.8	577.5	554.1	530.4	506.1
	kW	43.9	48.9	51.5	54.2	57.0	60.0	63.1	66.0	69.2	72.6	75.8
45	TC	818.3	766.9	750.5	726.2	702.0	678.1	655.5	631.1	605.0	579.0	553.9
	kW	45.1	50.0	52.7	55.5	58.3	61.2	64.4	67.6	70.7	74.0	77.5
50	TC	885.6	843.4	806.5	786.1	760.2	734.8	710.3	684.4	656.7	627.9	602.1
	kW	46.4	51.7	53.9	56.8	59.6	62.6	65.8	69.0	72.2	75.4	79.0

### 38APD080 CONDENSING UNIT RATINGS, 50 Hz ENGLISH

SST (F)*		CONDENSER ENTERING-AIR TEMPERATURE (F)										
		70	80	85	90	95	100	105	110	115	120	125
30	TC	696.9	659.3	640.0	620.5	600.7	580.7	560.3	540.3	519.4	498.1	476.4
	kW	45.5	50.4	53.1	55.9	58.8	61.9	65.1	68.5	72.0	75.7	79.5
35	TC	763.5	722.2	701.1	679.8	658.2	636.3	614.1	591.6	569.3	546.0	522.3
	kW	46.7	51.6	54.2	57.0	60.0	63.1	66.3	69.6	73.2	76.8	80.6
40	TC	831.8	786.5	763.2	739.9	716.3	692.5	668.3	643.7	618.7	593.2	568.2
	kW	48.0	52.8	55.5	58.3	61.2	64.3	67.5	70.8	74.3	78.0	81.7
45	TC	900.2	850.5	824.9	799.4	773.7	747.7	721.4	694.8	667.8	640.3	612.3
	kW	49.3	54.2	56.8	59.6	62.5	65.6	68.7	72.1	75.5	79.2	82.9
50	TC	967.5	914.3	886.3	858.4	830.3	802.1	773.4	744.5	715.1	685.5	654.6
	kW	50.8	55.6	58.2	61.0	63.9	66.9	70.0	73.3	76.8	80.4	84.1

### 38APD090 CONDENSING UNIT RATINGS, 50 Hz ENGLISH

SST (F)*		CONDENSER ENTERING-AIR TEMPERATURE (F)										
		70	80	85	90	95	100	105	110	115	120	125
30	TC	778.8	736.1	715.0	693.6	671.9	649.8	627.1	604.1	580.8	556.8	531.6
	kW	49.2	54.8	57.9	61.2	64.6	68.2	71.9	75.7	79.7	83.8	88.0
35	TC	853.0	806.3	783.3	759.8	735.8	711.6	687.0	661.8	636.2	610.2	583.5
	kW	50.3	55.9	59.0	62.2	65.6	69.2	72.8	76.7	80.7	84.8	89.0
40	TC	932.6	877.1	852.3	826.1	800.1	773.5	746.7	719.1	691.2	662.9	633.7
	kW	51.7	57.1	60.2	63.4	66.7	70.2	73.9	77.7	81.7	85.8	90.0
45	TC	1009.0	947.6	919.7	891.3	862.4	833.2	804.2	774.4	744.2	713.2	681.8
	kW	53.1	58.4	61.4	64.6	67.9	71.4	75.0	78.8	82.7	86.7	90.9
50	TC	1083.4	1015.2	985.2	953.9	921.5	889.9	857.7	825.3	792.8	759.9	725.7
	kW	54.6	59.8	62.8	65.9	69.2	72.6	76.2	79.9	83.8	87.8	91.9

#### LEGEND

**kW** — Compressor Power  
**SST** — Saturated Suction Temperature Entering Condensing Unit  
**TC** — Gross Cooling Capacity (1000 Btuh)

#### NOTES:

1. Ratings are based on 15 F superheat and use of R-410A refrigerant.
2. Ratings include suction line losses due to an accumulator.
3. Refer to Commercial Split Builder program for more detailed information.

\* 38AP units are not designed for refrigeration duty. Unit operational range should be reviewed to ensure that operation at full and part load conditions with saturated suction temperatures at or below 30 F are avoided. Operation below 30 F SST may result in ice build-up on evaporator coil, resulting in liquid flood-back and possible compressor failure.

# Performance data (cont)



## 38APD100 CONDENSING UNIT RATINGS, 50 Hz ENGLISH

SST (F)*		CONDENSER ENTERING-AIR TEMPERATURE (F)										
		70	80	85	90	95	100	105	110	115	120	125
30	TC	844.2	799.2	776.5	753.4	729.9	706.2	682.2	657.9	633.1	608.0	582.2
	kW	55.5	61.4	64.6	68.0	71.5	75.3	79.2	83.3	87.5	92.0	96.7
35	TC	927.9	878.8	853.9	828.6	803.1	777.2	751.0	724.4	697.4	669.9	641.7
	kW	57.2	63.1	66.3	69.7	73.2	76.9	80.8	84.9	89.2	93.6	98.3
40	TC	1015.6	961.9	934.7	907.2	879.4	851.4	822.7	793.7	764.3	734.1	703.4
	kW	58.9	64.8	68.0	71.4	74.9	78.7	82.6	86.6	90.9	95.3	99.9
45	TC	1106.2	1047.8	1018.1	988.2	957.9	927.3	896.2	864.8	832.7	799.9	765.9
	kW	60.7	66.7	69.9	73.2	76.8	80.5	84.4	88.4	92.6	97.0	101.6
50	TC	1199.4	1135.8	1103.5	1070.9	1037.9	1004.6	970.8	936.7	901.7	866.0	828.8
	kW	62.8	68.7	71.8	75.2	78.7	82.4	86.2	90.3	94.5	98.8	103.4

## 38APD115 CONDENSING UNIT RATINGS, 50 Hz ENGLISH

SST (F)*		CONDENSER ENTERING-AIR TEMPERATURE (F)										
		70	80	85	90	95	100	105	110	115	120	125
30	TC	960.2	905.7	879.0	851.9	823.6	795.5	768.4	740.2	712.2	681.5	653.6
	kW	64.5	71.8	75.7	79.9	84.2	88.7	93.4	98.3	103.4	108.7	114.1
35	TC	1057.2	998.3	969.7	939.7	909.5	878.9	848.0	817.1	786.6	755.1	723.0
	kW	66.1	73.4	77.4	81.5	85.8	90.4	95.1	100.0	105.1	110.4	115.8
40	TC	1161.2	1099.6	1064.4	1031.9	998.9	965.6	932.1	897.6	863.5	829.1	793.7
	kW	67.9	75.2	79.1	83.2	86.9	92.0	96.8	101.6	106.7	112.0	117.4
45	TC	1267.2	1198.9	1161.7	1126.0	1090.3	1053.6	1017.0	980.2	942.3	904.9	865.3
	kW	69.7	76.9	80.8	84.9	88.0	93.7	98.4	103.3	108.3	113.6	119.0
50	TC	1379.3	1299.6	1259.3	1220.4	1181.2	1141.4	1101.6	1060.8	1019.7	978.1	934.9
	kW	71.7	78.7	82.6	86.7	91.0	95.4	100.1	104.9	109.9	115.1	120.5

## 38APD130 CONDENSING UNIT RATINGS, 50 Hz ENGLISH

SST (F)*		CONDENSER ENTERING-AIR TEMPERATURE (F)										
		70	80	85	90	95	100	105	110	115	120	125
30	TC	1097.4	1036.2	1007.2	976.7	945.6	913.9	882.2	850.1	818.2	783.1	749.8
	kW	73.0	80.8	85.0	89.5	94.1	98.9	104.0	109.2	114.7	120.4	126.3
35	TC	1208.0	1141.9	1109.5	1075.2	1041.6	1008.2	973.1	937.4	902.2	866.4	829.6
	kW	75.0	82.9	87.1	91.5	96.2	101.0	106.1	111.4	116.9	122.5	128.5
40	TC	1321.3	1254.2	1215.5	1180.9	1143.3	1104.5	1068.0	1027.6	990.8	950.6	909.1
	kW	77.1	85.0	89.2	93.7	98.3	103.2	108.2	113.5	119.0	124.6	130.5
45	TC	1445.1	1366.9	1329.1	1289.1	1244.2	1203.9	1159.6	1137.7	1080.4	1035.7	1007.9
	kW	79.4	87.3	91.5	95.9	100.5	105.3	110.3	115.7	121.1	126.7	132.2
50	TC	1573.3	1485.2	1453.0	1392.5	1367.2	1310.0	1278.4	1210.9	1187.0	1118.4	1089.6
	kW	81.9	89.7	94.2	98.1	103.2	107.6	112.9	117.8	123.4	128.8	134.4

### LEGEND

- kW** — Compressor Power
- SST** — Saturated Suction Temperature Entering Condensing Unit
- TC** — Gross Cooling Capacity (1000 Btuh)

### NOTES:

1. Ratings are based on 15 F superheat and use of R-410A refrigerant.
2. Ratings include suction line losses due to an accumulator.
3. Refer to Commercial Split Builder program for more detailed information.

\* 38AP units are not designed for refrigeration duty. Unit operational range should be reviewed to ensure that operation at full and part load conditions with saturated suction temperatures at or below 30 F are avoided. Operation below 30 F SST may result in ice build-up on evaporator coil, resulting in liquid flood-back and possible compressor failure.



### 38APD025 CONDENSING UNIT CIRCUIT RATINGS, 50 Hz ENGLISH CIRCUIT A

SST (F)*		CONDENSER ENTERING-AIR TEMPERATURE (F)										
		70	80	85	90	95	100	105	110	115	120	125
30	TC	106.7	100.5	97.3	94.1	90.8	87.4	84.0	80.5	76.9	73.3	69.7
	kW	6.8	7.6	8.0	8.5	8.9	9.4	9.9	10.4	10.9	11.5	12.0
35	TC	117.7	110.9	107.5	104.0	100.4	96.8	93.2	89.4	85.6	81.7	77.8
	kW	6.9	7.7	8.2	8.6	9.1	9.5	10.0	10.6	11.1	11.6	12.2
40	TC	129.1	121.7	117.9	114.1	110.3	106.4	102.5	98.5	94.4	90.2	85.9
	kW	7.0	7.8	8.3	8.7	9.2	9.7	10.2	10.7	11.2	11.8	12.3
45	TC	140.6	132.4	128.2	124.0	119.9	115.7	111.5	107.1	102.7	98.2	93.6
	kW	7.2	7.9	8.4	8.8	9.3	9.8	10.3	10.8	11.3	11.9	12.5
50	TC	151.7	142.5	137.9	133.5	129.0	124.4	119.8	115.1	110.3	105.5	100.5
	kW	7.3	8.1	8.5	8.9	9.4	9.9	10.4	10.9	11.5	12.0	12.6

#### CIRCUIT B

SST (F)*		CONDENSER ENTERING-AIR TEMPERATURE (F)										
		70	80	85	90	95	100	105	110	115	120	125
30	TC	106.7	100.5	97.3	94.1	90.8	87.4	84.0	80.5	76.9	73.3	69.7
	kW	6.8	7.6	8.0	8.5	8.9	9.4	9.9	10.4	10.9	11.5	12.0
35	TC	117.7	110.9	107.5	104.0	100.4	96.8	93.2	89.4	85.6	81.7	77.8
	kW	6.9	7.7	8.2	8.6	9.1	9.5	10.0	10.6	11.1	11.6	12.2
40	TC	129.1	121.7	117.9	114.1	110.3	106.4	102.5	98.5	94.4	90.2	85.9
	kW	7.0	7.8	8.3	8.7	9.2	9.7	10.2	10.7	11.2	11.8	12.3
45	TC	140.6	132.4	128.2	124.0	119.9	115.7	111.5	107.1	102.7	98.2	93.6
	kW	7.2	7.9	8.4	8.8	9.3	9.8	10.3	10.8	11.3	11.9	12.5
50	TC	151.7	142.5	137.9	133.5	129.0	124.4	119.8	115.1	110.3	105.5	100.5
	kW	7.3	8.1	8.5	8.9	9.4	9.9	10.4	10.9	11.5	12.0	12.6

### 38APD027 CONDENSING UNIT CIRCUIT RATINGS, 50 Hz ENGLISH CIRCUIT A

SST (F)*		CONDENSER ENTERING-AIR TEMPERATURE (F)										
		70	80	85	90	95	100	105	110	115	120	125
30	TC	120.6	114.0	110.7	107.4	104.0	100.6	97.1	93.6	90.0	86.4	82.6
	kW	7.6	8.4	8.8	9.3	9.8	10.3	10.8	11.4	12.0	12.6	13.2
35	TC	132.3	125.2	121.5	117.8	114.2	110.5	106.7	102.9	99.0	95.0	90.9
	kW	7.8	8.6	9.0	9.5	10.0	10.5	11.0	11.6	12.2	12.8	13.4
40	TC	144.4	136.5	132.5	128.5	124.5	120.5	116.4	112.3	108.0	103.7	99.2
	kW	8.0	8.8	9.2	9.7	10.2	10.7	11.2	11.8	12.4	13.0	13.6
45	TC	156.4	147.6	143.2	138.9	134.6	130.2	125.8	121.3	116.7	112.1	107.3
	kW	8.3	9.0	9.5	9.9	10.4	10.9	11.4	12.0	12.6	13.2	13.8
50	TC	168.1	158.3	153.7	149.0	144.3	139.6	134.8	129.9	125.0	119.9	114.8
	kW	8.5	9.3	9.7	10.2	10.6	11.1	11.7	12.2	12.8	13.4	14.0

#### CIRCUIT B

SST (F)*		CONDENSER ENTERING-AIR TEMPERATURE (F)										
		70	80	85	90	95	100	105	110	115	120	125
30	TC	119.9	113.4	110.0	106.6	103.2	99.8	96.3	92.7	89.1	85.5	81.7
	kW	7.6	8.4	8.8	9.3	9.8	10.3	10.8	11.4	12.0	12.6	13.2
35	TC	131.4	124.1	120.4	116.6	112.9	109.2	105.4	101.5	97.6	93.6	89.5
	kW	7.8	8.6	9.1	9.5	10.0	10.5	11.0	11.6	12.2	12.8	13.4
40	TC	142.9	134.8	130.7	126.6	122.6	118.5	114.4	110.3	106.0	101.6	97.1
	kW	8.0	8.8	9.3	9.7	10.2	10.7	11.2	11.8	12.4	13.0	13.6
45	TC	154.4	145.4	140.8	136.5	132.1	127.7	123.2	118.7	114.0	109.3	104.5
	kW	8.3	9.1	9.5	9.9	10.4	10.9	11.5	12.0	12.6	13.2	13.8
50	TC	165.6	155.5	150.8	146.0	141.2	136.4	131.5	126.5	121.5	116.4	111.2
	kW	8.5	9.3	9.7	10.2	10.7	11.2	11.7	12.2	12.8	13.4	14.0

#### LEGEND

**kW** — Compressor Power  
**SST** — Saturated Suction Temperature Entering Condensing Unit  
**TC** — Gross Cooling Capacity (1000 Btuh)

#### NOTES:

1. Ratings are based on 15 F superheat and use of R-410A refrigerant.
2. Ratings include suction line losses due to an accumulator.
3. Refer to Commercial Split Builder program for more detailed information.

\* 38AP units are not designed for refrigeration duty. Unit operational range should be reviewed to ensure that operation at full and part load conditions with saturated suction temperatures at or below 30 F are avoided. Operation below 30 F SST may result in ice build-up on evaporator coil, resulting in liquid flood-back and possible compressor failure.

# Performance data (cont)



## 38APD030 CONDENSING UNIT CIRCUIT RATINGS, 50 Hz ENGLISH CIRCUIT A

SST (F)*		CONDENSER ENTERING-AIR TEMPERATURE (F)										
		70	80	85	90	95	100	105	110	115	120	125
30	TC	139.8	132.4	128.6	124.9	121.1	117.3	113.4	109.4	105.4	101.2	97.0
	kW	9.1	10.0	10.6	11.1	11.7	12.4	13.0	13.7	14.5	15.2	16.0
35	TC	152.9	144.9	140.8	136.9	132.8	128.7	124.5	120.2	115.9	111.4	106.8
	kW	9.3	10.3	10.8	11.4	12.0	12.6	13.3	14.0	14.7	15.4	16.2
40	TC	166.1	157.4	153.0	148.8	144.5	140.1	135.7	131.1	126.5	121.7	116.7
	kW	9.6	10.5	11.1	11.6	12.2	12.8	13.5	14.2	14.9	15.7	16.5
45	TC	179.0	169.5	164.9	160.4	155.8	151.2	146.5	141.7	136.8	131.8	126.5
	kW	9.9	10.8	11.3	11.9	12.5	13.1	13.8	14.4	15.2	15.9	16.7
50	TC	191.5	181.4	176.7	171.9	167.1	162.1	157.1	152.0	146.8	141.4	135.9
	kW	10.2	11.1	11.7	12.2	12.8	13.4	14.0	14.7	15.4	16.2	16.9

### CIRCUIT B

SST (F)*		CONDENSER ENTERING-AIR TEMPERATURE (F)										
		70	80	85	90	95	100	105	110	115	120	125
30	TC	139.9	132.5	128.8	125.0	121.2	117.3	113.4	109.4	105.4	101.3	97.1
	kW	9.2	10.2	10.7	11.3	11.9	12.5	13.2	13.9	14.6	15.4	16.2
35	TC	153.1	145.1	141.0	137.0	132.9	128.7	124.5	120.2	115.8	111.3	106.8
	kW	9.4	10.4	11.0	11.5	12.1	12.8	13.4	14.1	14.9	15.6	16.4
40	TC	166.4	157.6	153.3	149.0	144.6	140.2	135.7	131.1	126.4	121.5	116.5
	kW	9.7	10.7	11.2	11.8	12.4	13.0	13.7	14.4	15.1	15.9	16.7
45	TC	179.6	170.1	165.5	160.9	156.2	151.5	146.7	141.8	136.8	131.6	126.3
	kW	10.0	11.0	11.5	12.1	12.7	13.3	14.0	14.7	15.4	16.1	16.9
50	TC	192.7	182.5	177.6	172.7	167.7	162.6	157.5	152.2	146.9	141.4	135.7
	kW	10.3	11.3	11.8	12.4	13.0	13.6	14.3	14.9	15.7	16.4	17.2

## 38APD040 CONDENSING UNIT CIRCUIT RATINGS, 50 Hz ENGLISH CIRCUIT A

SST (F)*		CONDENSER ENTERING-AIR TEMPERATURE (F)										
		70	80	85	90	95	100	105	110	115	120	125
30	TC	187.6	176.3	170.6	164.8	158.8	152.7	146.7	140.5	134.2	127.5	121.1
	kW	11.7	13.2	13.9	14.7	15.5	16.4	17.2	18.1	19.0	19.9	20.9
35	TC	206.6	194.2	188.1	181.8	175.3	168.8	162.1	155.6	148.8	141.5	134.3
	kW	12.0	13.4	14.2	15.0	15.8	16.7	17.6	18.5	19.4	20.3	21.3
40	TC	226.3	213.2	206.2	199.3	192.3	185.2	178.3	171.0	163.8	156.2	147.9
	kW	12.2	13.7	14.5	15.3	16.1	17.0	17.9	18.8	19.8	20.7	21.7
45	TC	246.6	232.3	224.5	217.0	209.4	202.1	194.4	186.7	178.7	169.7	162.0
	kW	12.5	14.0	14.7	15.5	16.4	17.3	18.2	19.1	20.1	21.1	22.1
50	TC	267.2	251.1	243.3	235.3	227.1	218.9	209.9	201.3	193.1	183.7	175.2
	kW	12.8	14.2	15.0	15.8	16.7	17.6	18.5	19.4	20.4	21.4	22.4

### CIRCUIT B

SST (F)*		CONDENSER ENTERING-AIR TEMPERATURE (F)										
		70	80	85	90	95	100	105	110	115	120	125
30	TC	162.2	153.3	148.7	144.0	139.2	134.4	129.5	124.5	119.4	114.1	108.7
	kW	9.6	10.8	11.5	12.2	13.0	13.7	14.6	15.4	16.3	17.2	18.1
35	TC	178.3	168.4	163.5	158.3	153.1	147.8	142.5	137.1	131.6	125.7	119.8
	kW	9.7	11.0	11.7	12.4	13.1	13.9	14.7	15.6	16.5	17.4	18.4
40	TC	195.1	184.4	178.8	173.1	167.3	161.5	155.9	150.0	144.0	137.9	130.9
	kW	9.9	11.2	11.8	12.6	13.3	14.1	14.9	15.8	16.7	17.6	18.5
45	TC	212.4	200.7	194.3	188.0	181.7	175.5	169.2	162.7	156.1	149.3	142.7
	kW	10.1	11.3	12.0	12.7	13.5	14.3	15.1	16.0	16.8	17.8	18.7
50	TC	230.0	216.8	210.1	203.4	196.6	189.9	182.1	175.6	168.3	160.2	153.4
	kW	10.3	11.5	12.2	12.9	13.7	14.5	15.3	16.1	17.0	17.9	18.9

#### LEGEND

- kW** — Compressor Power
- SST** — Saturated Suction Temperature Entering Condensing Unit
- TC** — Gross Cooling Capacity (1000 Btuh)

#### NOTES:

1. Ratings are based on 15 F superheat and use of R-410A refrigerant.
2. Ratings include suction line losses due to an accumulator.
3. Refer to Commercial Split Builder program for more detailed information.

\* 38AP units are not designed for refrigeration duty. Unit operational range should be reviewed to ensure that operation at full and part load conditions with saturated suction temperatures at or below 30 F are avoided. Operation below 30 F SST may result in ice build-up on evaporator coil, resulting in liquid flood-back and possible compressor failure.

**38APD050 CONDENSING UNIT CIRCUIT RATINGS, 50 Hz ENGLISH**  
**CIRCUIT A**

SST (F)*		CONDENSER ENTERING-AIR TEMPERATURE (F)										
		70	80	85	90	95	100	105	110	115	120	125
30	TC	212.2	199.8	193.2	186.8	180.2	173.5	166.6	159.5	152.3	145.2	137.8
	kW	13.8	15.5	16.3	17.3	18.2	19.2	20.3	21.3	22.4	23.5	24.6
35	TC	233.4	219.9	212.9	205.8	198.6	191.5	184.1	176.7	169.1	160.9	153.4
	kW	14.0	15.7	16.6	17.5	18.5	19.5	20.6	21.6	22.7	23.8	25.0
40	TC	255.6	240.9	233.2	225.5	217.9	210.1	202.2	194.2	186.0	176.9	168.2
	kW	14.2	15.9	16.8	17.7	18.7	19.8	20.8	21.9	23.0	24.2	25.3
45	TC	278.5	262.3	253.8	245.5	237.0	228.9	220.3	211.6	202.0	192.8	183.9
	kW	14.4	16.1	17.0	18.0	19.0	20.0	21.1	22.2	23.3	24.4	25.6
50	TC	301.7	284.1	274.6	266.1	256.9	247.8	238.5	228.2	218.5	209.4	199.1
	kW	14.7	16.3	17.2	18.2	19.2	20.2	21.3	22.4	23.5	24.7	25.9

**CIRCUIT B**

SST (F)*		CONDENSER ENTERING-AIR TEMPERATURE (F)										
		70	80	85	90	95	100	105	110	115	120	125
30	TC	236.9	223.7	216.8	210.2	203.3	196.4	189.4	182.0	174.6	167.5	159.5
	kW	16.2	17.8	18.7	19.6	20.6	21.7	22.7	23.9	25.0	26.3	27.5
35	TC	259.6	245.0	237.5	230.1	222.4	215.1	207.4	199.6	191.6	183.2	175.0
	kW	16.7	18.3	19.2	20.1	21.1	22.2	23.2	24.4	25.5	26.7	28.0
40	TC	283.2	267.1	258.7	250.5	242.6	234.2	225.6	217.0	208.1	198.6	189.3
	kW	17.2	18.8	19.7	20.7	21.7	22.7	23.8	24.9	26.0	27.2	28.4
45	TC	306.7	289.5	280.1	271.3	262.2	253.4	243.8	234.0	224.9	214.4	204.1
	kW	17.8	19.4	20.3	21.2	22.2	23.2	24.3	25.4	26.5	27.7	28.9
50	TC	331.0	311.5	301.9	292.6	282.4	272.4	261.6	252.0	240.5	229.7	220.0
	kW	18.4	20.0	20.9	21.8	22.8	23.8	24.8	25.9	27.1	28.2	29.5

**38APD060 CONDENSING UNIT CIRCUIT RATINGS, 50 Hz ENGLISH**  
**CIRCUIT A**

SST (F)*		CONDENSER ENTERING-AIR TEMPERATURE (F)										
		70	80	85	90	95	100	105	110	115	120	125
30	TC	238.1	225.1	218.6	211.9	205.3	198.6	191.8	185.0	178.0	170.9	163.7
	kW	14.9	16.5	17.4	18.3	19.2	20.2	21.3	22.4	23.5	24.8	26.0
35	TC	260.7	245.9	239.2	232.0	224.8	217.5	210.1	202.6	195.1	187.3	179.5
	kW	15.3	16.9	17.8	18.7	19.6	20.6	21.7	22.8	23.9	25.2	26.4
40	TC	283.9	268.1	260.3	252.5	244.7	236.8	228.8	220.7	212.5	204.1	195.7
	kW	15.8	17.4	18.2	19.1	20.1	21.1	22.1	23.2	24.4	25.6	26.8
45	TC	307.8	290.8	281.9	273.4	265.0	256.4	247.7	239.0	230.1	221.0	212.0
	kW	16.3	17.9	18.7	19.6	20.5	21.5	22.6	23.7	24.8	26.0	27.3
50	TC	334.0	316.5	299.0	295.4	285.7	277.0	266.8	258.0	248.0	238.6	228.7
	kW	16.8	18.0	19.2	20.1	21.1	22.1	23.1	24.2	25.3	26.5	27.7

**CIRCUIT B**

SST (F)*		CONDENSER ENTERING-AIR TEMPERATURE (F)										
		70	80	85	90	95	100	105	110	115	120	125
30	TC	278.3	263.0	255.3	247.5	239.7	231.7	223.7	215.9	207.6	199.4	190.2
	kW	18.7	20.7	21.8	22.9	24.1	25.3	26.6	28.0	29.4	30.9	32.4
35	TC	305.0	288.4	280.0	271.5	263.0	254.4	245.6	236.7	227.8	218.6	209.7
	kW	19.3	21.3	22.3	23.5	24.6	25.9	27.2	28.5	30.0	31.4	33.0
40	TC	332.9	314.7	305.4	296.3	287.0	277.7	268.2	258.5	248.9	238.9	228.7
	kW	19.9	21.9	22.9	24.1	25.3	26.5	27.8	29.1	30.6	32.0	33.6
45	TC	361.5	341.6	331.6	321.6	311.6	301.5	291.2	280.9	270.4	259.3	248.6
	kW	20.6	22.5	23.6	24.7	25.9	27.1	28.4	29.8	31.2	32.6	34.2
50	TC	390.5	374.5	358.5	347.7	336.6	325.9	314.4	303.5	291.7	280.5	268.3
	kW	21.3	22.8	24.3	25.4	26.6	27.8	29.1	30.5	31.8	33.3	34.8

**LEGEND**

**kW** — Compressor Power  
**SST** — Saturated Suction Temperature Entering Condensing Unit  
**TC** — Gross Cooling Capacity (1000 Btuh)

**NOTES:**

1. Ratings are based on 15 F superheat and use of R-410A refrigerant.
2. Ratings include suction line losses due to an accumulator.
3. Refer to Commercial Split Builder program for more detailed information.

\* 38AP units are not designed for refrigeration duty. Unit operational range should be reviewed to ensure that operation at full and part load conditions with saturated suction temperatures at or below 30 F are avoided. Operation below 30 F SST may result in ice build-up on evaporator coil, resulting in liquid flood-back and possible compressor failure.

# Performance data (cont)



## 38APD070 CONDENSING UNIT CIRCUIT RATINGS, 50 Hz ENGLISH

### CIRCUIT A

SST (F)*		CONDENSER ENTERING-AIR TEMPERATURE (F)										
		70	80	85	90	95	100	105	110	115	120	125
30	TC	307.5	290.2	283.5	274.3	264.7	252.3	245.2	232.8	225.0	212.1	204.2
	kW	20.8	23.3	24.5	25.9	27.2	28.7	30.1	31.6	33.0	34.7	36.2
35	TC	339.5	319.3	311.8	301.8	291.4	281.2	271.1	257.4	249.3	236.4	227.2
	kW	21.4	23.8	25.1	26.4	27.8	29.2	30.8	32.3	33.8	35.5	37.0
40	TC	370.7	349.3	341.0	330.1	319.2	308.9	297.8	285.9	274.3	262.7	250.6
	kW	22.0	24.4	25.7	27.0	28.4	29.9	31.5	32.9	34.5	36.2	37.8
45	TC	404.0	378.9	371.0	359.1	347.3	335.5	324.4	312.4	299.7	286.8	274.5
	kW	22.5	25.0	26.3	27.7	29.1	30.5	32.1	33.7	35.3	36.9	38.6
50	TC	437.4	416.7	398.7	388.8	376.1	363.6	351.6	338.8	325.2	311.2	298.3
	kW	23.2	25.8	26.9	28.3	29.7	31.2	32.8	34.4	36.0	37.6	39.4

### CIRCUIT B

SST (F)*		CONDENSER ENTERING-AIR TEMPERATURE (F)										
		70	80	85	90	95	100	105	110	115	120	125
30	TC	314.8	297.3	290.1	280.6	270.8	258.1	250.7	238.0	229.9	216.8	208.5
	kW	20.9	23.3	24.6	26.0	27.3	28.8	30.2	31.8	33.2	34.9	36.3
35	TC	347.8	327.1	319.2	308.7	297.8	287.4	277.0	262.9	254.4	241.3	231.6
	kW	21.4	23.9	25.2	26.5	27.9	29.4	30.9	32.5	34.0	35.7	37.2
40	TC	379.9	357.8	349.1	337.4	326.0	315.4	304.1	291.6	279.8	267.7	255.5
	kW	22.0	24.5	25.8	27.1	28.6	30.1	31.6	33.1	34.7	36.4	38.0
45	TC	414.2	388.0	379.5	367.1	354.7	342.6	331.1	318.7	305.4	292.2	279.4
	kW	22.6	25.1	26.4	27.8	29.2	30.7	32.3	33.9	35.5	37.1	38.9
50	TC	448.3	426.8	407.7	397.3	384.1	371.2	358.7	345.5	331.5	316.7	303.8
	kW	23.2	25.9	27.0	28.5	29.9	31.4	33.0	34.6	36.2	37.8	39.6

## 38APD080 CONDENSING UNIT CIRCUIT RATINGS, 50 Hz ENGLISH

### CIRCUIT A

SST (F)*		CONDENSER ENTERING-AIR TEMPERATURE (F)										
		70	80	85	90	95	100	105	110	115	120	125
30	TC	279.3	264.1	256.3	248.5	240.6	232.6	224.4	216.4	208.0	199.6	190.9
	kW	18.3	20.2	21.2	22.3	23.4	24.6	25.9	27.2	28.6	30.0	31.5
35	TC	306.4	289.6	281.1	272.5	263.8	254.9	246.0	236.9	228.0	218.6	209.1
	kW	18.9	20.7	21.8	22.9	24.0	25.2	26.4	27.7	29.1	30.5	32.0
40	TC	334.4	316.0	306.5	297.1	287.5	277.8	268.1	258.1	247.9	237.6	227.5
	kW	19.5	21.3	22.4	23.4	24.6	25.7	27.0	28.3	29.6	31.0	32.5
45	TC	363.1	342.8	332.4	322.0	311.5	300.9	290.2	279.4	268.4	257.3	245.8
	kW	20.1	22.0	23.0	24.0	25.2	26.3	27.6	28.9	30.2	31.6	33.1
50	TC	391.9	370.2	358.8	347.5	336.0	324.4	312.7	300.8	288.8	276.7	264.0
	kW	20.7	22.6	23.6	24.7	25.8	27.0	28.2	29.5	30.8	32.2	33.6

### CIRCUIT B

SST (F)*		CONDENSER ENTERING-AIR TEMPERATURE (F)										
		70	80	85	90	95	100	105	110	115	120	125
30	TC	417.6	395.1	383.6	372.0	360.2	348.1	335.9	323.9	311.4	298.5	285.6
	kW	27.2	30.2	31.8	33.5	35.4	37.2	39.2	41.3	43.4	45.7	48.0
35	TC	457.1	432.6	420.0	407.3	394.5	381.4	368.1	354.7	341.3	327.4	313.2
	kW	27.8	30.8	32.5	34.2	36.0	37.9	39.9	41.9	44.1	46.3	48.6
40	TC	497.4	470.5	456.6	442.8	428.8	414.6	400.3	385.6	370.7	355.6	340.7
	kW	28.5	31.5	33.1	34.9	36.7	38.5	40.5	42.6	44.7	46.9	49.2
45	TC	537.1	507.7	492.5	477.4	462.2	446.7	431.2	415.4	399.4	383.1	366.4
	kW	29.2	32.2	33.8	35.6	37.3	39.2	41.2	43.2	45.3	47.5	49.9
50	TC	575.7	544.0	527.5	511.0	494.3	477.7	460.7	443.7	426.3	408.9	390.7
	kW	30.0	33.0	34.6	36.3	38.1	39.9	41.8	43.9	46.0	48.2	50.5

#### LEGEND

- kW** — Compressor Power
- SST** — Saturated Suction Temperature Entering Condensing Unit
- TC** — Gross Cooling Capacity (1000 Btuh)

#### NOTES:

1. Ratings are based on 15 F superheat and use of R-410A refrigerant.
2. Ratings include suction line losses due to an accumulator.
3. Refer to Commercial Split Builder program for more detailed information.

\* 38AP units are not designed for refrigeration duty. Unit operational range should be reviewed to ensure that operation at full and part load conditions with saturated suction temperatures at or below 30 F are avoided. Operation below 30 F SST may result in ice build-up on evaporator coil, resulting in liquid flood-back and possible compressor failure.

### 38APD090 CONDENSING UNIT CIRCUIT RATINGS, 50 Hz ENGLISH CIRCUIT A

SST (F)*		CONDENSER ENTERING-AIR TEMPERATURE (F)										
		70	80	85	90	95	100	105	110	115	120	125
30	TC	360.5	340.1	330.3	320.5	310.4	300.2	289.6	278.8	267.9	256.6	244.5
	kW	22.0	24.6	26.0	27.6	29.2	30.8	32.6	34.4	36.2	38.1	39.9
35	TC	394.4	372.3	361.6	350.7	339.5	328.2	316.8	304.9	292.8	280.7	268.2
	kW	22.5	25.1	26.5	28.0	29.6	31.2	32.9	34.7	36.5	38.4	40.3
40	TC	431.7	404.9	393.2	380.9	368.6	356.2	343.7	330.6	317.5	304.3	290.7
	kW	23.1	25.6	27.0	28.4	30.0	31.6	33.3	35.1	36.9	38.8	40.7
45	TC	467.6	437.8	424.3	410.7	397.1	383.3	369.5	355.5	341.6	327.1	312.4
	kW	23.7	26.1	27.5	29.0	30.5	32.1	33.7	35.5	37.3	39.1	41.0
50	TC	502.3	469.0	454.7	439.5	423.8	408.8	393.4	378.2	363.1	347.7	331.9
	kW	24.4	26.7	28.1	29.5	31.0	32.6	34.2	35.9	37.7	39.5	41.4

#### CIRCUIT B

SST (F)*		CONDENSER ENTERING-AIR TEMPERATURE (F)										
		70	80	85	90	95	100	105	110	115	120	125
30	TC	418.4	396.0	384.7	373.1	361.5	349.6	337.5	325.3	312.9	300.2	287.1
	kW	27.2	30.2	31.9	33.6	35.4	37.3	39.3	41.4	43.5	45.7	48.0
35	TC	458.5	434.0	421.7	409.2	396.3	383.4	370.3	356.9	343.4	329.5	315.3
	kW	27.9	30.9	32.5	34.3	36.1	38.0	39.9	42.0	44.1	46.4	48.7
40	TC	500.9	472.2	459.1	445.2	431.4	417.3	403.0	388.5	373.7	358.6	343.0
	kW	28.6	31.5	33.2	34.9	36.7	38.6	40.6	42.6	44.8	47.0	49.3
45	TC	541.4	509.8	495.4	480.6	465.3	449.9	434.6	418.9	402.6	386.1	369.5
	kW	29.3	32.3	33.9	35.6	37.4	39.3	41.3	43.3	45.4	47.6	49.9
50	TC	581.1	546.1	530.5	514.4	497.8	481.2	464.2	447.2	429.7	412.3	393.8
	kW	30.2	33.0	34.7	36.4	38.1	40.0	41.9	44.0	46.1	48.3	50.5

### 38APD100 CONDENSING UNIT CIRCUIT RATINGS, 50 Hz ENGLISH CIRCUIT A

SST (F)*		CONDENSER ENTERING-AIR TEMPERATURE (F)										
		70	80	85	90	95	100	105	110	115	120	125
30	TC	422.3	399.8	388.4	376.9	365.1	353.3	341.2	329.1	316.7	304.1	291.2
	kW	27.8	30.7	32.3	34.0	35.8	37.7	39.6	41.7	43.8	46.0	48.3
35	TC	464.2	439.6	427.1	414.5	401.7	388.7	375.6	362.3	348.8	335.0	320.9
	kW	28.6	31.6	33.2	34.9	36.6	38.5	40.4	42.5	44.6	46.8	49.2
40	TC	508.0	481.1	467.5	453.8	439.9	425.8	411.5	396.9	382.2	367.1	351.7
	kW	29.5	32.4	34.0	35.7	37.5	39.4	41.3	43.3	45.5	47.7	50.0
45	TC	553.4	524.1	509.3	494.3	479.1	463.8	448.2	432.5	416.4	400.0	383.0
	kW	30.4	33.4	35.0	36.7	38.4	40.3	42.2	44.2	46.3	48.5	50.8
50	TC	600.1	568.2	552.0	535.7	519.2	502.5	485.5	468.4	450.9	433.0	414.4
	kW	31.4	34.4	36.0	37.6	39.4	41.2	43.1	45.2	47.3	49.4	51.7

#### CIRCUIT B

SST (F)*		CONDENSER ENTERING-AIR TEMPERATURE (F)										
		70	80	85	90	95	100	105	110	115	120	125
30	TC	421.9	399.4	388.0	376.5	364.8	352.9	341.0	328.8	316.4	303.9	291.0
	kW	27.7	30.7	32.3	34.0	35.7	37.6	39.6	41.6	43.8	46.0	48.3
35	TC	463.7	439.2	426.8	414.2	401.4	388.5	375.4	362.1	348.6	334.9	320.8
	kW	28.5	31.5	33.1	34.8	36.6	38.4	40.4	42.4	44.6	46.8	49.1
40	TC	507.6	480.8	467.2	453.5	439.6	425.6	411.3	396.8	382.1	367.0	351.7
	kW	29.4	32.4	34.0	35.7	37.4	39.3	41.3	43.3	45.4	47.6	49.9
45	TC	552.8	523.7	508.9	493.9	478.8	463.5	448.0	432.3	416.3	399.9	383.0
	kW	30.3	33.3	34.9	36.6	38.3	40.2	42.1	44.2	46.3	48.5	50.8
50	TC	599.3	567.6	551.5	535.2	518.8	502.1	485.3	468.2	450.8	433.0	414.4
	kW	31.3	34.3	35.9	37.6	39.3	41.2	43.1	45.1	47.2	49.4	51.7

#### LEGEND

**kW** — Compressor Power  
**SST** — Saturated Suction Temperature Entering Condensing Unit  
**TC** — Gross Cooling Capacity (1000 Btuh)

#### NOTES:

1. Ratings are based on 15 F superheat and use of R-410A refrigerant.
2. Ratings include suction line losses due to an accumulator.
3. Refer to Commercial Split Builder program for more detailed information.

\* 38AP units are not designed for refrigeration duty. Unit operational range should be reviewed to ensure that operation at full and part load conditions with saturated suction temperatures at or below 30 F are avoided. Operation below 30 F SST may result in ice build-up on evaporator coil, resulting in liquid flood-back and possible compressor failure.

# Performance data (cont)



## 38APD115 CONDENSING UNIT CIRCUIT RATINGS, 50 Hz ENGLISH

### CIRCUIT A

SST (F)*		CONDENSER ENTERING-AIR TEMPERATURE (F)										
		70	80	85	90	95	100	105	110	115	120	125
30	TC	424.0	401.3	390.0	378.5	366.4	354.3	342.7	330.5	317.9	305.7	292.6
	kW	27.8	30.9	32.6	34.4	36.2	38.2	40.2	42.3	44.5	46.8	49.1
35	TC	466.1	441.7	429.5	416.8	403.9	391.0	377.7	364.6	351.1	337.4	323.4
	kW	28.5	31.6	33.3	35.1	36.9	38.9	40.9	43.0	45.2	47.5	49.8
40	TC	510.7	484.6	470.4	456.7	442.8	428.6	414.3	399.5	385.0	369.8	354.4
	kW	29.2	32.3	34.0	35.7	37.6	39.5	41.5	43.6	45.8	48.1	50.4
45	TC	556.3	527.6	512.3	497.2	482.2	466.6	451.0	435.2	419.3	402.7	385.5
	kW	29.9	33.0	34.7	36.4	38.3	40.2	42.2	44.3	46.5	48.7	51.0
50	TC	603.1	570.3	553.8	537.5	520.9	504.0	487.2	469.8	452.2	434.0	415.3
	kW	30.7	33.7	35.4	37.1	39.0	40.9	42.8	44.9	47.1	49.3	51.6

### CIRCUIT B

SST (F)*		CONDENSER ENTERING-AIR TEMPERATURE (F)										
		70	80	85	90	95	100	105	110	115	120	125
30	TC	536.2	504.3	489.0	473.5	457.2	441.1	425.6	409.6	394.2	375.8	361.1
	kW	36.7	40.8	43.1	45.5	47.9	50.5	53.2	56.0	58.9	61.9	65.0
35	TC	591.1	556.6	540.3	523.0	505.6	488.0	470.3	452.5	435.5	417.8	399.5
	kW	37.7	41.8	44.1	46.5	48.9	51.5	54.2	57.0	59.9	62.9	66.0
40	TC	650.5	615.0	594.0	575.2	556.2	536.9	517.8	498.1	478.4	459.3	439.2
	kW	38.7	42.9	45.1	47.5	49.3	52.5	55.2	58.0	60.9	63.9	67.0
45	TC	710.9	671.3	649.4	628.8	608.1	587.1	566.0	545.0	523.0	502.1	479.8
	kW	39.7	43.9	46.1	48.5	49.7	53.5	56.2	59.0	61.9	64.9	68.0
50	TC	776.1	729.3	705.6	683.0	660.3	637.4	614.3	591.0	567.4	544.2	519.5
	kW	41.0	45.0	47.2	49.6	52.0	54.6	57.2	60.0	62.9	65.8	68.9

## 38APD130 CONDENSING UNIT CIRCUIT RATINGS, 50 Hz ENGLISH

### CIRCUIT A

SST (F)*		CONDENSER ENTERING-AIR TEMPERATURE (F)										
		70	80	85	90	95	100	105	110	115	120	125
30	TC	423.9	401.4	390.0	378.4	366.5	354.3	342.2	329.9	317.5	303.0	290.3
	kW	27.9	31.1	32.8	34.5	36.4	38.3	40.4	42.5	44.7	47.0	49.3
35	TC	466.8	441.9	429.3	416.2	403.4	390.9	377.4	363.6	350.0	336.4	322.3
	kW	28.6	31.8	33.5	35.2	37.1	39.0	41.1	43.2	45.4	47.7	50.0
40	TC	506.5	484.2	470.0	456.9	442.6	428.1	413.9	398.7	384.3	368.9	353.0
	kW	29.2	32.5	34.1	35.9	37.8	39.7	41.8	43.9	46.1	48.3	50.7
45	TC	556.5	527.1	513.1	498.0	481.4	466.1	449.6	440.5	418.1	401.7	390.8
	kW	30.1	33.2	34.9	36.6	38.5	40.4	42.4	44.5	46.7	49.0	51.1
50	TC	604.4	571.0	558.8	536.8	526.7	509.6	493.3	468.8	458.5	433.4	421.2
	kW	30.9	34.0	35.7	37.3	39.3	41.2	43.2	45.2	47.4	49.6	51.8

### CIRCUIT B

SST (F)*		CONDENSER ENTERING-AIR TEMPERATURE (F)										
		70	80	85	90	95	100	105	110	115	120	125
30	TC	673.5	634.7	617.2	598.3	579.1	559.5	540.0	520.2	500.7	480.0	459.5
	kW	45.1	49.7	52.3	54.9	57.7	60.6	63.6	66.7	70.0	73.5	77.0
35	TC	741.2	700.1	680.1	659.0	638.2	617.3	595.7	573.8	552.2	529.9	507.3
	kW	46.4	51.1	53.7	56.3	59.1	62.0	65.0	68.2	71.4	74.9	78.4
40	TC	814.8	770.0	745.5	724.0	700.7	676.4	654.1	628.9	606.5	581.7	556.1
	kW	47.9	52.6	55.1	57.7	60.5	63.4	66.5	69.6	72.9	76.3	79.8
45	TC	888.6	839.8	816.0	791.1	762.8	737.9	710.0	697.2	662.2	634.1	617.1
	kW	49.3	54.1	56.6	59.3	62.0	64.9	67.9	71.2	74.4	77.7	81.1
50	TC	968.9	914.2	894.2	855.7	840.4	800.4	785.1	742.1	728.5	685.0	668.4
	kW	51.0	55.7	58.5	60.8	63.9	66.4	69.7	72.6	76.0	79.2	82.6

#### LEGEND

- kW** — Compressor Power
- SST** — Saturated Suction Temperature Entering Condensing Unit
- TC** — Gross Cooling Capacity (1000 Btuh)

#### NOTES:

1. Ratings are based on 15 F superheat and use of R-410A refrigerant.
2. Ratings include suction line losses due to an accumulator.
3. Refer to Commercial Split Builder program for more detailed information.

\* 38AP units are not designed for refrigeration duty. Unit operational range should be reviewed to ensure that operation at full and part load conditions with saturated suction temperatures at or below 30 F are avoided. Operation below 30 F SST may result in ice build-up on evaporator coil, resulting in liquid flood-back and possible compressor failure.



### 38APD,APS025 CONDENSING UNIT RATINGS, 50 Hz SI

SST (C)*		CONDENSER ENTERING-AIR TEMPERATURE (C)										
		21	27	30	32	35	38	41	43	46	49	52
0	TC	65.2	61.1	59.0	57.6	55.4	53.2	51.0	49.5	47.2	44.9	42.4
	kW	13.7	15.4	16.3	17.0	18.0	19.0	20.1	20.8	21.9	23.1	24.3
2	TC	69.9	65.5	63.3	61.8	59.6	57.3	54.9	53.3	50.9	48.4	45.9
	kW	13.9	15.6	16.5	17.1	18.1	19.2	20.3	21.0	22.2	23.3	24.5
4	TC	74.7	70.1	67.7	66.1	63.7	61.3	58.8	57.1	54.6	52.0	49.3
	kW	14.0	15.7	16.7	17.3	18.3	19.4	20.5	21.2	22.4	23.5	24.8
6	TC	79.5	74.6	72.0	70.3	67.8	65.3	62.7	60.9	58.2	55.4	52.6
	kW	14.2	15.9	16.8	17.4	18.5	19.5	20.6	21.4	22.5	23.7	25.0
8	TC	84.3	79.0	76.2	74.5	71.8	69.1	66.3	64.5	61.6	58.7	55.7
	kW	14.4	16.1	17.0	17.6	18.6	19.7	20.8	21.5	22.7	23.9	25.1
10	TC	89.0	83.2	80.3	78.4	75.6	72.7	69.8	67.8	64.8	61.7	58.5
	kW	14.5	16.2	17.1	17.8	18.8	19.8	20.9	21.7	22.9	24.1	25.3

### 38APD,APS027 CONDENSING UNIT RATINGS, 50 Hz SI

SST (C)*		CONDENSER ENTERING-AIR TEMPERATURE (C)										
		21	27	30	32	35	38	41	43	46	49	52
0	TC	73.3	69.0	66.8	65.3	63.0	60.8	58.5	57.0	54.6	52.2	49.8
	kW	15.4	17.1	18.0	18.7	19.7	20.8	22.0	22.8	24.1	25.4	26.8
2	TC	78.2	73.6	71.2	69.6	67.3	64.9	62.5	60.8	58.3	55.8	53.1
	kW	15.7	17.4	18.3	19.0	20.0	21.1	22.3	23.1	24.3	25.6	27.0
4	TC	83.2	78.2	75.7	74.0	71.5	69.0	66.4	64.7	62.0	59.3	56.5
	kW	16.0	17.7	18.6	19.3	20.3	21.4	22.6	23.4	24.6	25.9	27.3
6	TC	88.2	82.8	80.0	78.3	75.7	73.0	70.2	68.4	65.6	62.7	59.8
	kW	16.3	18.0	18.9	19.6	20.6	21.7	22.9	23.7	24.9	26.2	27.6
8	TC	93.1	87.3	84.4	82.6	79.7	76.9	74.0	72.0	69.1	66.0	62.9
	kW	16.7	18.3	19.3	19.9	21.0	22.0	23.2	24.0	25.2	26.5	27.8
10	TC	97.9	91.6	88.7	86.7	83.7	80.7	77.6	75.5	72.4	69.1	65.9
	kW	17.0	18.7	19.6	20.3	21.3	22.4	23.5	24.3	25.5	26.8	28.1

### 38APD,APS030 CONDENSING UNIT RATINGS, 50 Hz SI

SST (C)*		CONDENSER ENTERING-AIR TEMPERATURE (C)										
		21	27	30	32	35	38	41	43	46	49	52
0	TC	85.1	80.3	77.8	76.2	73.7	71.2	68.7	66.9	64.3	61.6	58.8
	kW	18.4	20.5	21.7	22.5	23.8	25.2	26.6	27.6	29.2	30.8	32.6
2	TC	90.7	85.6	83.0	81.3	78.7	76.1	73.4	71.5	68.8	65.9	63.0
	kW	18.8	20.9	22.0	22.9	24.2	25.5	27.0	28.0	29.5	31.2	32.9
4	TC	96.3	90.8	88.1	86.3	83.6	80.9	78.1	76.1	73.2	70.2	67.1
	kW	19.2	21.3	22.4	23.2	24.5	25.9	27.3	28.3	29.9	31.5	33.2
6	TC	101.8	96.0	93.2	91.3	88.5	85.6	82.7	80.7	77.7	74.5	71.2
	kW	19.6	21.7	22.8	23.6	24.9	26.3	27.7	28.7	30.3	31.9	33.6
8	TC	107.3	101.2	98.3	96.3	93.3	90.3	87.2	85.1	82.0	78.7	75.3
	kW	20.0	22.1	23.2	24.1	25.3	26.7	28.1	29.1	30.6	32.3	33.9
10	TC	112.7	106.3	103.3	101.2	98.1	94.9	91.7	89.5	86.2	82.8	79.2
	kW	20.5	22.5	23.7	24.5	25.8	27.1	28.5	29.5	31.0	32.6	34.3

#### LEGEND

**kW** — Compressor Power  
**SST** — Saturated Suction Temperature Entering Condensing Unit  
**TC** — Gross Cooling Capacity (kW)

#### NOTES:

1. Ratings are based on 8.3 C superheat and use of R-410A refrigerant.
2. Ratings include suction line losses due to an accumulator.
3. Refer to Commercial Split Builder program for more detailed information.

\* 38AP units are not designed for refrigeration duty. Unit operational range should be reviewed to ensure that operation at full and part load conditions with saturated suction temperatures at or below 0° C are avoided. Operation below 0° C SST may result in ice build-up on evaporator coil, resulting in liquid flood-back and possible compressor failure.

# Performance data (cont)



## 38APD040 CONDENSING UNIT RATINGS, 50 Hz SI

SST (C)*		CONDENSER ENTERING-AIR TEMPERATURE (C)										
		21	27	30	32	35	38	41	43	46	49	52
0	TC	106.7	100.1	96.7	94.4	90.9	87.3	83.7	81.2	77.6	73.6	69.8
	kW	21.4	24.3	25.9	27.0	28.7	30.4	32.3	33.5	35.5	37.5	39.5
2	TC	114.2	107.1	103.5	101.2	97.3	93.6	89.8	87.1	83.3	79.1	74.9
	kW	21.7	24.6	26.2	27.3	29.0	30.8	32.6	33.9	35.9	37.9	40.0
4	TC	121.9	114.5	110.5	107.9	103.9	99.9	96.0	93.0	89.1	84.5	80.3
	kW	22.0	24.9	26.5	27.6	29.3	31.1	33.0	34.3	36.3	38.3	40.4
6	TC	129.8	121.9	117.6	114.8	110.5	106.4	102.1	99.2	94.5	90.1	85.2
	kW	22.3	25.3	26.8	27.9	29.7	31.5	33.3	34.6	36.6	38.7	40.8
8	TC	137.8	129.3	124.7	121.7	117.4	112.9	108.3	105.2	100.3	95.7	90.7
	kW	22.7	25.6	27.2	28.3	30.0	31.8	33.7	35.0	37.0	39.1	41.2
10	TC	146.0	136.6	132.0	128.6	124.2	119.4	114.4	110.8	105.9	101.1	95.5
	kW	23.0	26.0	27.5	28.6	30.4	32.2	34.0	35.3	37.3	39.4	41.6

## 38APS040 CONDENSING UNIT RATINGS, 50 Hz SI

SST (C)*		CONDENSER ENTERING-AIR TEMPERATURE (C)										
		21	27	30	32	35	38	41	43	46	49	52
0	TC	107.2	100.8	97.4	95.2	91.8	88.3	84.8	82.5	79.0	75.4	71.7
	kW	21.3	23.8	25.1	26.1	27.6	29.2	30.9	32.0	33.8	35.8	37.8
2	TC	114.6	107.7	104.1	101.8	98.0	94.4	90.6	88.1	84.4	80.6	76.7
	kW	21.7	24.2	25.6	26.5	28.0	29.6	31.3	32.5	34.3	36.2	38.2
4	TC	122.2	114.9	111.0	108.4	104.5	100.5	96.7	93.9	90.1	86.0	81.5
	kW	22.2	24.7	26.0	27.0	28.5	30.1	31.8	32.9	34.7	36.6	38.6
6	TC	130.2	122.2	118.1	115.3	111.1	107.2	102.9	99.9	95.9	91.5	86.7
	kW	22.7	25.2	26.5	27.5	29.0	30.6	32.2	33.4	35.2	37.1	39.1
8	TC	138.4	130.1	125.4	122.5	118.3	113.9	109.4	106.1	101.5	96.8	92.0
	kW	23.2	25.7	27.1	28.0	29.5	31.1	32.8	33.9	35.7	37.6	39.6
10	TC	146.9	137.6	132.9	129.8	125.4	120.7	115.9	112.3	107.5	102.8	97.4
	kW	23.8	26.3	27.6	28.6	30.1	31.6	33.3	34.4	36.2	38.1	40.1

## 38APD050 CONDENSING UNIT RATINGS, 50 Hz SI

SST (C)*		CONDENSER ENTERING-AIR TEMPERATURE (C)										
		21	27	30	32	35	38	41	43	46	49	52
0	TC	136.9	128.5	124.0	121.1	116.8	112.3	107.8	104.7	99.9	95.1	90.2
	kW	30.2	33.8	35.7	37.1	39.2	41.4	43.7	45.2	47.6	50.2	52.7
2	TC	146.2	137.3	132.6	129.5	124.9	120.2	115.3	112.0	106.8	101.9	96.7
	kW	30.7	34.3	36.2	37.6	39.7	41.9	44.2	45.8	48.2	50.8	53.4
4	TC	155.9	146.3	141.3	138.0	133.1	128.1	123.0	119.5	114.2	108.3	103.0
	kW	31.2	34.8	36.8	38.1	40.3	42.5	44.8	46.4	48.8	51.3	54.0
6	TC	165.6	155.5	150.1	146.6	141.4	136.0	130.6	126.9	121.1	115.1	109.5
	kW	31.8	35.4	37.3	38.7	40.8	43.0	45.4	47.0	49.4	51.9	54.6
8	TC	175.6	164.6	159.0	155.2	149.8	144.1	138.3	134.3	127.9	121.7	115.8
	kW	32.4	36.0	37.9	39.3	41.4	43.6	45.9	47.5	49.9	52.5	55.1
10	TC	185.6	173.8	167.8	163.8	158.2	152.1	145.7	141.6	135.2	128.5	122.0
	kW	33.0	36.6	38.5	39.8	42.0	44.2	46.5	48.1	50.5	53.0	55.7

### LEGEND

- kW** — Compressor Power
- SST** — Saturated Suction Temperature Entering Condensing Unit
- TC** — Gross Cooling Capacity (kW)

### NOTES:

1. Ratings are based on 8.3 C superheat and use of R-410A refrigerant.
2. Ratings include suction line losses due to an accumulator.
3. Refer to Commercial Split Builder program for more detailed information.

\* 38AP units are not designed for refrigeration duty. Unit operational range should be reviewed to ensure that operation at full and part load conditions with saturated suction temperatures at or below 0° C are avoided. Operation below 0° C SST may result in ice build-up on evaporator coil, resulting in liquid flood-back and possible compressor failure.

### 38APS050 CONDENSING UNIT RATINGS, 50 Hz SI

SST (C)*		CONDENSER ENTERING-AIR TEMPERATURE (C)										
		21	27	30	32	35	38	41	43	46	49	52
0	TC	128.8	121.3	117.4	114.6	110.8	106.5	102.6	99.6	95.6	90.9	86.1
	kW	27.7	31.0	32.8	34.0	36.0	37.9	40.1	41.5	43.8	46.1	48.5
2	TC	137.7	129.6	125.6	122.8	118.6	114.1	109.9	106.7	102.4	97.4	92.7
	kW	28.3	31.5	33.3	34.5	36.5	38.5	40.6	42.0	44.3	46.6	49.0
4	TC	147.0	138.3	133.8	130.8	126.5	121.9	117.3	114.1	108.9	104.2	98.7
	kW	28.8	32.1	33.8	35.1	37.0	39.0	41.1	42.6	44.8	47.1	49.5
6	TC	156.4	147.2	142.3	139.1	134.4	129.5	124.6	121.1	115.7	110.3	105.2
	kW	29.4	32.6	34.4	35.6	37.5	39.5	41.6	43.0	45.2	47.6	50.0
8	TC	165.9	156.1	150.8	147.4	142.4	137.1	131.8	128.1	122.2	116.9	111.0
	kW	30.0	33.2	34.9	36.1	38.0	40.0	42.1	43.5	45.7	48.1	50.4
10	TC	175.4	164.8	159.1	155.4	150.1	144.4	138.8	134.8	128.4	122.8	116.5
	kW	30.5	33.7	35.5	36.7	38.6	40.5	42.6	44.0	46.2	48.5	50.9

### 38APD060 CONDENSING UNIT RATINGS, 50 Hz SI

SST (C)*		CONDENSER ENTERING-AIR TEMPERATURE (C)										
		21	27	30	32	35	38	41	43	46	49	52
0	TC	157.7	147.7	143.6	140.2	135.7	130.9	126.2	123.2	118.2	113.2	107.7
	kW	34.0	37.8	39.9	41.4	43.7	46.1	48.7	50.4	53.2	56.1	59.2
2	TC	167.7	157.3	152.9	149.5	144.9	139.7	134.4	131.0	125.9	120.7	115.5
	kW	34.7	38.5	40.6	42.1	44.4	46.8	49.4	51.1	53.9	56.8	59.8
4	TC	178.6	168.0	162.7	159.0	153.9	148.5	143.1	139.8	134.2	128.9	122.6
	kW	35.5	39.3	41.4	42.8	45.1	47.6	50.1	51.9	54.7	57.6	60.6
6	TC	189.6	177.6	172.0	169.0	163.3	157.2	151.5	148.0	142.2	136.7	130.5
	kW	36.3	40.1	42.2	43.6	45.9	48.3	50.9	52.7	55.4	58.3	61.3
8	TC	201.4	187.2	180.8	177.4	170.8	165.9	159.5	156.2	150.0	143.4	137.0
	kW	37.2	40.9	43.0	44.5	46.7	49.2	51.7	53.5	56.2	59.1	62.1
10	TC	210.8	195.7	190.5	186.4	180.8	174.1	168.0	164.7	158.5	151.6	144.6
	kW	38.1	41.8	43.9	45.3	47.6	50.0	52.5	54.3	57.1	59.9	62.9

### 38APS065 CONDENSING UNIT RATINGS, 50 Hz SI

SST (C)*		CONDENSER ENTERING-AIR TEMPERATURE (C)										
		21	27	30	32	35	38	41	43	46	49	52
0	TC	162.6	151.9	146.5	142.9	137.3	132.0	126.3	122.7	117.2	111.4	105.5
	kW	36.1	40.2	42.4	43.9	46.3	48.8	51.4	53.3	56.1	59.0	62.1
2	TC	173.8	162.5	156.7	152.9	147.0	141.3	135.3	131.3	125.4	119.2	113.3
	kW	36.9	41.0	43.2	44.7	47.1	49.7	52.3	54.1	56.9	59.8	62.9
4	TC	185.6	173.4	167.3	163.2	157.1	150.9	144.6	140.6	134.1	127.5	121.4
	kW	37.8	41.9	44.1	45.6	48.0	50.5	53.1	55.0	57.8	60.7	63.8
6	TC	197.8	184.8	178.3	174.1	167.4	160.8	154.2	150.0	143.0	136.3	129.2
	kW	38.7	42.8	45.0	46.5	48.9	51.4	54.0	55.9	58.7	61.6	64.6
8	TC	210.4	196.4	189.8	185.3	178.1	171.1	163.8	159.2	152.0	145.0	137.4
	kW	39.7	43.7	45.9	47.5	49.9	52.4	55.0	56.8	59.6	62.5	65.5
10	TC	223.7	208.8	201.8	196.5	188.7	181.4	173.5	168.9	161.5	153.6	145.9
	kW	40.7	44.7	47.0	48.5	50.8	53.3	55.9	57.8	60.6	63.4	66.4

#### LEGEND

**kW** — Compressor Power  
**SST** — Saturated Suction Temperature Entering Condensing Unit  
**TC** — Gross Cooling Capacity (kW)

#### NOTES:

1. Ratings are based on 8.3 C superheat and use of R-410A refrigerant.
2. Ratings include suction line losses due to an accumulator.
3. Refer to Commercial Split Builder program for more detailed information.

\* 38AP units are not designed for refrigeration duty. Unit operational range should be reviewed to ensure that operation at full and part load conditions with saturated suction temperatures at or below 0° C are avoided. Operation below 0° C SST may result in ice build-up on evaporator coil, resulting in liquid flood-back and possible compressor failure.

# Performance data (cont)



## 38APD070 CONDENSING UNIT RATINGS, 50 Hz SI

SST (C)*		CONDENSER ENTERING-AIR TEMPERATURE (C)										
		21	27	30	32	35	38	41	43	46	49	52
0	TC	190.8	178.4	173.8	168.6	163.4	155.5	150.6	144.5	139.4	130.2	125.6
	kW	42.1	47.3	50.2	52.1	55.0	58.2	61.4	63.6	66.9	70.3	73.5
2	TC	203.9	190.8	186.1	181.3	175.0	168.4	161.4	156.2	149.9	141.4	135.5
	kW	42.9	48.2	51.0	53.0	55.9	59.1	62.2	64.4	67.9	71.5	74.7
4	TC	217.2	203.5	198.5	193.4	186.8	179.9	172.5	167.0	160.6	151.0	145.3
	kW	43.7	49.0	51.9	53.8	56.8	60.0	63.2	65.4	69.0	72.7	76.0
6	TC	230.9	216.6	211.2	205.8	198.8	191.6	184.2	178.0	171.2	163.2	155.4
	kW	44.5	49.8	52.8	54.7	57.8	61.0	64.3	66.5	70.0	73.4	77.1
8	TC	246.3	229.7	224.1	218.4	211.0	203.4	195.2	189.4	181.9	173.8	165.4
	kW	45.4	50.7	53.7	55.7	58.7	61.9	65.2	67.6	71.0	74.6	78.2
10	TC	260.3	241.8	236.4	230.7	223.7	215.2	206.8	200.2	193.0	184.1	175.5
	kW	46.3	51.5	54.6	56.5	59.7	62.9	66.2	68.3	72.1	75.6	79.4

## 38APD080 CONDENSING UNIT RATINGS, 50 Hz SI

SST (C)*		CONDENSER ENTERING-AIR TEMPERATURE (C)										
		21	27	30	32	35	38	41	43	46	49	52
0	TC	212.3	199.9	193.5	189.3	182.8	176.2	169.5	165.1	158.3	151.3	144.2
	kW	45.9	51.2	54.1	56.1	59.3	62.6	66.1	68.5	72.3	76.3	80.4
2	TC	226.4	213.2	206.4	201.9	195.0	187.9	180.8	176.0	168.9	161.4	153.8
	kW	46.7	52.0	54.9	57.0	60.1	63.5	67.0	69.4	73.2	77.1	81.2
4	TC	240.8	226.7	219.4	214.6	207.2	199.7	192.2	187.1	179.3	171.4	163.5
	kW	47.6	53.0	55.8	57.9	61.0	64.3	67.8	70.2	74.0	77.9	82.0
6	TC	255.3	240.1	232.4	227.2	219.4	211.4	203.4	197.9	189.7	181.3	172.8
	kW	48.6	53.9	56.8	58.8	61.9	65.2	68.7	71.1	74.9	78.8	82.8
8	TC	269.6	253.6	245.3	239.7	231.4	223.0	214.4	208.7	199.9	191.0	181.9
	kW	49.6	54.9	57.8	59.8	62.9	66.2	69.6	72.0	75.8	79.6	83.7
10	TC	283.9	267.0	258.1	252.2	243.3	234.4	225.3	219.2	209.9	200.5	190.8
	kW	50.7	56.0	58.8	60.8	63.9	67.1	70.6	73.0	76.6	80.5	84.5

## 38APD090 CONDENSING UNIT RATINGS, 50 Hz SI

SST (C)*		CONDENSER ENTERING-AIR TEMPERATURE (C)										
		21	27	30	32	35	38	41	43	46	49	52
0	TC	237.2	223.1	216.2	211.4	204.4	197.1	189.7	184.5	177.1	169.3	160.8
	kW	49.5	55.6	59.0	61.3	65.0	68.8	72.9	75.6	79.9	84.4	88.9
2	TC	252.9	237.9	230.6	225.5	218.0	210.2	202.3	196.8	188.8	180.5	171.7
	kW	50.4	56.4	59.8	62.1	65.7	69.6	73.6	76.3	80.6	85.1	89.6
4	TC	269.9	252.9	245.0	239.6	231.5	223.3	214.8	209.0	200.4	191.6	182.3
	kW	51.3	57.3	60.6	62.9	66.5	70.3	74.3	77.1	81.3	85.8	90.3
6	TC	286.2	267.7	259.3	253.5	244.7	235.9	227.0	220.9	211.7	202.3	192.6
	kW	52.3	58.2	61.5	63.8	67.4	71.1	75.1	77.8	82.1	86.5	91.0
8	TC	302.2	282.6	273.4	267.3	257.9	248.4	238.8	232.4	222.6	212.7	202.4
	kW	53.3	59.2	62.4	64.7	68.2	72.0	75.9	78.6	82.8	87.2	91.7
10	TC	317.7	296.5	286.9	280.3	270.2	260.0	249.9	243.1	232.8	222.3	211.6
	kW	54.4	60.1	63.4	65.7	69.2	72.9	76.7	79.4	83.6	87.9	92.4

### LEGEND

- kW** — Compressor Power
- SST** — Saturated Suction Temperature Entering Condensing Unit
- TC** — Gross Cooling Capacity (kW)

### NOTES:

1. Ratings are based on 8.3 C superheat and use of R-410A refrigerant.
2. Ratings include suction line losses due to an accumulator.
3. Refer to Commercial Split Builder program for more detailed information.

\* 38AP units are not designed for refrigeration duty. Unit operational range should be reviewed to ensure that operation at full and part load conditions with saturated suction temperatures at or below 0° C are avoided. Operation below 0° C SST may result in ice build-up on evaporator coil, resulting in liquid flood-back and possible compressor failure.

### 38APD100 CONDENSING UNIT RATINGS, 50 Hz SI

SST (C)*		CONDENSER ENTERING-AIR TEMPERATURE (C)										
		21	27	30	32	35	38	41	43	46	49	52
0	TC	261.0	246.0	238.4	233.3	225.5	217.7	209.7	204.3	196.1	187.7	179.1
	kW	56.3	62.7	66.2	68.6	72.4	76.5	80.7	83.7	88.3	93.1	98.1
2	TC	279.0	263.1	255.0	249.5	241.3	232.9	224.4	218.6	209.9	201.0	191.8
	kW	57.5	63.9	67.4	69.8	73.7	77.7	81.9	84.9	89.5	94.3	99.3
4	TC	297.0	280.7	272.1	266.3	257.5	248.6	239.5	233.4	224.1	214.6	204.8
	kW	60.0	65.2	68.7	71.1	74.9	79.0	83.2	86.1	90.7	95.5	100.4
6	TC	316.7	298.7	289.5	283.3	274.0	264.5	254.9	248.4	238.5	228.4	217.9
	kW	60.1	66.5	70.0	72.4	76.2	80.2	84.5	87.4	91.9	96.7	101.6
8	TC	336.1	317.0	307.2	300.7	290.8	280.7	270.5	263.6	253.1	242.4	231.1
	kW	61.5	67.9	71.4	73.8	77.6	81.6	85.8	88.7	93.2	98.0	102.9
10	TC	356.0	335.6	325.2	318.2	307.7	297.0	286.1	278.8	267.6	256.2	244.2
	kW	63.0	69.3	72.8	75.2	79.0	83.0	87.1	90.0	94.6	99.3	104.2

### 38APD115 CONDENSING UNIT RATINGS, 50 Hz SI

SST (C)*		CONDENSER ENTERING-AIR TEMPERATURE (C)										
		21	27	30	32	35	38	41	43	46	49	52
0	TC	292.8	275.0	266.4	260.3	251.3	242.1	233.2	226.4	217.8	208.2	198.6
	kW	65.0	72.9	77.2	80.2	84.8	89.7	94.8	98.3	103.9	109.6	115.5
2	TC	313.8	295.1	285.7	279.3	269.7	260.0	250.1	243.3	233.6	223.6	213.2
	kW	66.2	74.1	78.4	81.4	86.0	90.9	96.1	99.6	105.1	110.8	116.7
4	TC	335.7	315.5	305.6	298.7	288.5	278.2	267.6	260.3	250.2	239.2	228.0
	kW	67.4	75.3	79.6	82.6	87.3	92.1	97.3	100.8	106.3	112.0	117.9
6	TC	357.9	337.2	325.9	318.6	307.7	296.6	285.5	277.8	266.8	255.0	243.1
	kW	68.7	76.6	80.8	83.8	88.5	93.3	98.4	101.9	107.4	113.1	119.0
8	TC	380.5	358.5	346.4	338.6	327.0	315.2	303.3	295.1	283.4	271.0	258.0
	kW	70.0	77.9	82.1	85.1	89.7	94.6	99.6	103.1	108.6	114.2	120.1
10	TC	404.2	379.5	366.8	358.6	346.2	333.7	321.2	312.1	299.7	286.4	272.4
	kW	71.5	79.2	83.4	86.4	91.0	95.8	100.8	104.3	109.7	115.4	121.2

### 38APD130 CONDENSING UNIT RATINGS, 50 Hz SI

SST (C)*		CONDENSER ENTERING-AIR TEMPERATURE (C)										
		21	27	30	32	35	38	41	43	46	49	52
0	TC	334.6	314.5	305.1	300.2	288.3	278.0	267.5	260.4	249.9	239.3	227.3
	kW	73.6	82.1	86.7	90.0	94.9	100.2	105.6	109.4	115.3	121.5	127.9
2	TC	358.5	337.3	326.7	321.9	309.0	298.0	287.1	281.9	268.4	256.5	244.4
	kW	75.1	83.6	88.2	91.5	96.4	101.7	107.2	111.0	117.0	123.0	129.4
4	TC	381.5	360.8	349.1	344.4	330.6	318.5	306.6	301.5	286.6	274.0	261.5
	kW	76.6	85.2	89.7	93.1	98.0	103.2	108.7	112.4	118.4	124.5	130.9
6	TC	409.0	384.6	373.2	367.1	351.6	339.5	326.8	321.4	305.4	292.0	283.7
	kW	78.3	86.8	91.4	94.7	99.5	104.8	110.2	114.0	119.9	126.0	132.1
8	TC	435.3	409.1	396.3	390.1	373.5	360.4	346.7	341.4	329.2	310.2	300.8
	kW	80.0	88.4	93.0	96.4	101.1	106.3	111.8	115.6	121.4	127.6	133.5
10	TC	461.5	433.8	423.3	412.9	400.7	382.7	370.9	358.9	348.2	326.9	318.4
	kW	81.8	90.2	95.0	98.0	103.1	108.0	113.6	117.2	123.1	129.1	135.2

#### LEGEND

- kW** — Compressor Power
- SST** — Saturated Suction Temperature Entering Condensing Unit
- TC** — Gross Cooling Capacity (kW)

\* 38AP units are not designed for refrigeration duty. Unit operational range should be reviewed to ensure that operation at full and part load conditions with saturated suction temperatures at or below 0° C are avoided. Operation below 0° C SST may result in ice build-up on evaporator coil, resulting in liquid flood-back and possible compressor failure.

#### NOTES:

1. Ratings are based on 8.3 C superheat and use of R-410A refrigerant.
2. Ratings include suction line losses due to an accumulator.
3. Refer to Commercial Split Builder program for more detailed information.

# Performance data (cont)



## 38APD025 CONDENSING UNIT CIRCUIT RATINGS, 50 Hz SI CIRCUIT A

SST (C*)		CONDENSER ENTERING-AIR TEMPERATURE (C)										
		21	27	30	32	35	38	41	43	46	49	52
0	TC	32.6	30.5	29.5	28.8	27.7	26.6	25.5	24.8	23.6	22.4	21.2
	kW	6.9	7.7	8.2	8.5	9.0	9.5	10.0	10.4	11.0	11.5	12.1
2	TC	34.9	32.8	31.7	30.9	29.8	28.6	27.5	26.7	25.4	24.2	22.9
	kW	6.9	7.8	8.3	8.6	9.1	9.6	10.1	10.5	11.1	11.7	12.3
4	TC	37.3	35.0	33.8	33.0	31.9	30.6	29.4	28.6	27.3	26.0	24.6
	kW	7.0	7.9	8.3	8.6	9.2	9.7	10.2	10.6	11.2	11.8	12.4
6	TC	39.8	37.3	36.0	35.2	33.9	32.6	31.3	30.4	29.1	27.7	26.3
	kW	7.1	7.9	8.4	8.7	9.2	9.8	10.3	10.7	11.3	11.9	12.5
8	TC	42.2	39.5	38.1	37.2	35.9	34.6	33.2	32.2	30.8	29.3	27.8
	kW	7.2	8.0	8.5	8.8	9.3	9.8	10.4	10.8	11.4	12.0	12.6
10	TC	44.5	41.6	40.2	39.2	37.8	36.4	34.9	33.9	32.4	30.8	29.3
	kW	7.3	8.1	8.6	8.9	9.4	9.9	10.5	10.9	11.4	12.0	12.7

## CIRCUIT B

SST (C)*		CONDENSER ENTERING-AIR TEMPERATURE (C)										
		21	27	30	32	35	38	41	43	46	49	52
0	TC	32.6	30.5	29.5	28.8	27.7	26.6	25.5	24.8	23.6	22.4	21.2
	kW	6.9	7.7	8.2	8.5	9.0	9.5	10.0	10.4	11.0	11.5	12.1
2	TC	34.9	32.8	31.7	30.9	29.8	28.6	27.5	26.7	25.4	24.2	22.9
	kW	6.9	7.8	8.3	8.6	9.1	9.6	10.1	10.5	11.1	11.7	12.3
4	TC	37.3	35.0	33.8	33.0	31.9	30.6	29.4	28.6	27.3	26.0	24.6
	kW	7.0	7.9	8.3	8.6	9.2	9.7	10.2	10.6	11.2	11.8	12.4
6	TC	39.8	37.3	36.0	35.2	33.9	32.6	31.3	30.4	29.1	27.7	26.3
	kW	7.1	7.9	8.4	8.7	9.2	9.8	10.3	10.7	11.3	11.9	12.5
8	TC	42.2	39.5	38.1	37.2	35.9	34.6	33.2	32.2	30.8	29.3	27.8
	kW	7.2	8.0	8.5	8.8	9.3	9.8	10.4	10.8	11.4	12.0	12.6
10	TC	44.5	41.6	40.2	39.2	37.8	36.4	34.9	33.9	32.4	30.8	29.3
	kW	7.3	8.1	8.6	8.9	9.4	9.9	10.5	10.9	11.4	12.0	12.7

### LEGEND

- kW** — Compressor Power
- SST** — Saturated Suction Temperature Entering Condensing Unit
- TC** — Gross Cooling Capacity (kW)

### NOTES:

1. Ratings are based on 8.3 C superheat and use of R-410A refrigerant.
2. Ratings include suction line losses due to an accumulator.
3. Refer to Commercial Split Builder program for more detailed information.

\* 38AP units are not designed for refrigeration duty. Unit operational range should be reviewed to ensure that operation at full and part load conditions with saturated suction temperatures at or below 0° C are avoided. Operation below 0° C SST may result in ice build-up on evaporator coil, resulting in liquid flood-back and possible compressor failure.



**38APD027 CONDENSING UNIT CIRCUIT RATINGS, 50 Hz SI**  
**CIRCUIT A**

SST (C)*		CONDENSER ENTERING-AIR TEMPERATURE (C)										
		21	27	30	32	35	38	41	43	46	49	52
0	TC	36.7	34.6	33.5	32.8	31.7	30.5	29.4	28.6	27.5	26.3	25.1
	kW	7.7	8.5	9.0	9.3	9.9	10.4	11.0	11.4	12.0	12.7	13.4
2	TC	39.3	37.0	35.8	35.0	33.8	32.7	31.4	30.6	29.4	28.1	26.8
	kW	7.8	8.7	9.2	9.5	10.0	10.6	11.1	11.5	12.2	12.8	13.5
4	TC	41.8	39.3	38.1	37.2	36.0	34.8	33.5	32.6	31.3	29.9	28.5
	kW	8.0	8.8	9.3	9.6	10.2	10.7	11.3	11.7	12.3	13.0	13.6
6	TC	44.4	41.7	40.3	39.5	38.2	36.8	35.5	34.6	33.2	31.7	30.3
	kW	8.1	9.0	9.5	9.8	10.3	10.8	11.4	11.8	12.4	13.1	13.8
8	TC	46.9	44.0	42.6	41.7	40.2	38.8	37.4	36.4	34.9	33.4	31.9
	kW	8.3	9.2	9.6	10.0	10.5	11.0	11.6	12.0	12.6	13.2	13.9
10	TC	49.3	46.2	44.8	43.8	42.3	40.8	39.3	38.2	36.7	35.1	33.5
	kW	8.5	9.3	9.8	10.1	10.6	11.2	11.7	12.1	12.7	13.4	14.1

**CIRCUIT B**

SST (C)*		CONDENSER ENTERING-AIR TEMPERATURE (C)										
		21	27	30	32	35	38	41	43	46	49	52
0	TC	36.5	34.4	33.2	32.5	31.4	30.3	29.1	28.3	27.2	26.0	24.7
	kW	7.7	8.5	9.0	9.3	9.9	10.4	11.0	11.4	12.0	12.7	13.4
2	TC	39.0	36.6	35.4	34.6	33.4	32.3	31.0	30.2	28.9	27.7	26.3
	kW	7.8	8.7	9.2	9.5	10.0	10.6	11.1	11.5	12.2	12.8	13.5
4	TC	41.4	38.9	37.6	36.7	35.5	34.2	32.9	32.1	30.7	29.4	28.0
	kW	8.0	8.9	9.3	9.6	10.2	10.7	11.3	11.7	12.3	13.0	13.6
6	TC	43.8	41.1	39.7	38.8	37.5	36.1	34.8	33.9	32.4	31.0	29.5
	kW	8.2	9.0	9.5	9.8	10.3	10.9	11.4	11.8	12.5	13.1	13.8
8	TC	46.2	43.3	41.9	40.9	39.5	38.1	36.6	35.6	34.1	32.6	31.0
	kW	8.3	9.2	9.7	10.0	10.5	11.0	11.6	12.0	12.6	13.2	13.9
10	TC	48.6	45.4	43.9	42.9	41.4	39.9	38.3	37.3	35.7	34.1	32.4
	kW	8.5	9.4	9.8	10.2	10.7	11.2	11.8	12.2	12.8	13.4	14.1

LEGEND

**kW** — Compressor Power  
**SST** — Saturated Suction Temperature Entering Condensing Unit  
**TC** — Gross Cooling Capacity (kW)

NOTES:

1. Ratings are based on 8.3 C superheat and use of R-410A refrigerant.
2. Ratings include suction line losses due to an accumulator.
3. Refer to Commercial Split Builder program for more detailed information.

\* 38AP units are not designed for refrigeration duty. Unit operational range should be reviewed to ensure that operation at full and part load conditions with saturated suction temperatures at or below 0° C are avoided. Operation below 0° C SST may result in ice build-up on evaporator coil, resulting in liquid flood-back and possible compressor failure.

# Performance data (cont)



## 38APD030 CONDENSING UNIT CIRCUIT RATINGS, 50 Hz SI CIRCUIT A

SST (C)*		CONDENSER ENTERING-AIR TEMPERATURE (C)										
		21	27	30	32	35	38	41	43	46	49	52
0	TC	42.5	40.1	38.9	38.1	36.9	35.6	34.3	33.5	32.1	30.8	29.4
	kW	9.1	10.2	10.8	11.2	11.8	12.5	13.2	13.7	14.5	15.3	16.2
2	TC	45.3	42.8	41.5	40.6	39.3	38.0	36.7	35.8	34.4	33.0	31.5
	kW	9.3	10.4	10.9	11.4	12.0	12.7	13.4	13.9	14.7	15.5	16.4
4	TC	48.1	45.4	44.0	43.1	41.8	40.4	39.0	38.1	36.6	35.1	33.6
	kW	9.5	10.6	11.1	11.5	12.2	12.9	13.6	14.1	14.8	15.7	16.5
6	TC	50.8	48.0	46.5	45.6	44.2	42.8	41.3	40.3	38.8	37.3	35.6
	kW	9.7	10.8	11.3	11.7	12.4	13.0	13.8	14.3	15.0	15.8	16.7
8	TC	53.6	50.5	49.1	48.1	46.6	45.1	43.6	42.6	41.0	39.4	37.7
	kW	9.9	11.0	11.5	11.9	12.6	13.2	14.0	14.4	15.2	16.0	16.9
10	TC	56.2	53.0	51.5	50.5	49.0	47.4	45.8	44.7	43.1	41.4	39.6
	kW	10.2	11.2	11.8	12.2	12.8	13.5	14.2	14.6	15.4	16.2	17.0

## CIRCUIT B

SST (C)*		CONDENSER ENTERING-AIR TEMPERATURE (C)										
		21	27	30	32	35	38	41	43	46	49	52
0	TC	42.6	40.2	38.9	38.1	36.9	35.6	34.3	33.5	32.2	30.8	29.4
	kW	9.3	10.3	10.9	11.3	12.0	12.7	13.4	13.9	14.7	15.5	16.4
2	TC	45.4	42.8	41.5	40.7	39.4	38.0	36.7	35.8	34.4	32.9	31.5
	kW	9.4	10.5	11.1	11.5	12.2	12.9	13.6	14.1	14.9	15.7	16.5
4	TC	48.2	45.5	44.1	43.2	41.8	40.5	39.0	38.1	36.6	35.1	33.5
	kW	9.6	10.7	11.3	11.7	12.4	13.0	13.8	14.3	15.0	15.9	16.7
6	TC	51.0	48.1	46.7	45.7	44.3	42.8	41.4	40.4	38.8	37.2	35.6
	kW	9.8	10.9	11.5	11.9	12.6	13.2	14.0	14.5	15.2	16.1	16.9
8	TC	53.8	50.7	49.2	48.2	46.7	45.2	43.6	42.6	41.0	39.3	37.6
	kW	10.1	11.1	11.7	12.1	12.8	13.4	14.2	14.7	15.4	16.2	17.1
10	TC	56.5	53.3	51.8	50.7	49.1	47.5	45.9	44.8	43.1	41.4	39.6
	kW	10.3	11.4	11.9	12.3	13.0	13.7	14.4	14.9	15.6	16.4	17.3

### LEGEND

- kW — Compressor Power
- SST — Saturated Suction Temperature Entering Condensing Unit
- TC — Gross Cooling Capacity (kW)

### NOTES:

1. Ratings are based on 8.3 C superheat and use of R-410A refrigerant.
2. Ratings include suction line losses due to an accumulator.
3. Refer to Commercial Split Builder program for more detailed information.

\* 38AP units are not designed for refrigeration duty. Unit operational range should be reviewed to ensure that operation at full and part load conditions with saturated suction temperatures at or below 0° C are avoided. Operation below 0° C SST may result in ice build-up on evaporator coil, resulting in liquid flood-back and possible compressor failure.

### 38APD040 CONDENSING UNIT CIRCUIT RATINGS, 50 Hz SI CIRCUIT A

SST (C)*		CONDENSER ENTERING-AIR TEMPERATURE (C)										
		21	27	30	32	35	38	41	43	46	49	52
0	TC	57.2	53.5	51.7	50.4	48.5	46.5	44.5	43.1	41.1	38.9	36.8
	kW	11.8	13.4	14.2	14.8	15.6	16.6	17.5	18.1	19.1	20.1	21.2
2	TC	61.3	57.4	55.4	54.1	52.0	49.9	47.8	46.3	44.2	41.9	39.6
	kW	12.0	13.5	14.4	15.0	15.8	16.8	17.7	18.4	19.4	20.4	21.5
4	TC	65.5	61.4	59.2	57.7	55.6	53.3	51.2	49.6	47.4	44.9	42.6
	kW	12.2	13.7	14.6	15.1	16.1	17.0	18.0	18.6	19.7	20.7	21.8
6	TC	69.7	65.4	63.0	61.5	59.1	56.9	54.5	52.9	50.4	47.9	45.3
	kW	12.4	13.9	14.8	15.3	16.3	17.2	18.2	18.9	19.9	21.0	22.0
8	TC	74.0	69.4	66.9	65.3	62.9	60.4	57.9	56.2	53.5	51.0	48.2
	kW	12.6	14.1	15.0	15.6	16.5	17.4	18.4	19.1	20.1	21.2	22.3
10	TC	78.5	73.4	70.8	69.0	66.6	64.0	61.3	59.3	56.7	54.0	50.8
	kW	12.8	14.3	15.2	15.8	16.7	17.6	18.6	19.3	20.4	21.4	22.5

### CIRCUIT B

SST (C)*		CONDENSER ENTERING-AIR TEMPERATURE (C)										
		21	27	30	32	35	38	41	43	46	49	52
0	TC	49.4	46.5	45.0	44.0	42.4	40.8	39.2	38.1	36.5	34.7	33.0
	kW	9.6	11.0	11.7	12.2	13.0	13.9	14.8	15.4	16.3	17.3	18.4
2	TC	52.9	49.8	48.1	47.1	45.4	43.7	42.0	40.8	39.1	37.2	35.3
	kW	9.7	11.1	11.8	12.3	13.1	14.0	14.9	15.5	16.5	17.5	18.5
4	TC	56.4	53.1	51.3	50.2	48.4	46.6	44.8	43.5	41.7	39.6	37.7
	kW	9.8	11.2	12.0	12.5	13.3	14.1	15.0	15.6	16.6	17.6	18.6
6	TC	60.1	56.5	54.6	53.3	51.4	49.5	47.6	46.3	44.2	42.2	40.0
	kW	10.0	11.3	12.1	12.6	13.4	14.3	15.2	15.8	16.7	17.7	18.8
8	TC	63.8	59.9	57.9	56.4	54.5	52.4	50.4	49.0	46.8	44.7	42.5
	kW	10.1	11.5	12.2	12.7	13.5	14.4	15.3	15.9	16.9	17.9	18.9
10	TC	67.5	63.3	61.1	59.6	57.6	55.5	53.0	51.5	49.2	47.1	44.7
	kW	10.3	11.6	12.4	12.9	13.7	14.5	15.4	16.0	17.0	18.0	19.0

#### LEGEND

**kW** — Compressor Power  
**SST** — Saturated Suction Temperature Entering Condensing Unit  
**TC** — Gross Cooling Capacity (kW)

#### NOTES:

1. Ratings are based on 8.3 C superheat and use of R-410A refrigerant.
2. Ratings include suction line losses due to an accumulator.
3. Refer to Commercial Split Builder program for more detailed information.

\* 38AP units are not designed for refrigeration duty. Unit operational range should be reviewed to ensure that operation at full and part load conditions with saturated suction temperatures at or below 0° C are avoided. Operation below 0° C SST may result in ice build-up on evaporator coil, resulting in liquid flood-back and possible compressor failure.

# Performance data (cont)



## 38APD050 CONDENSING UNIT CIRCUIT RATINGS, 50 Hz SI CIRCUIT A

SST (C)*		CONDENSER ENTERING-AIR TEMPERATURE (C)										
		21	27	30	32	35	38	41	43	46	49	52
0	TC	64.7	60.7	58.5	57.1	55.0	52.8	50.6	49.0	46.7	44.4	41.9
	kW	13.8	15.7	16.6	17.3	18.3	19.4	20.5	21.3	22.5	23.7	24.9
2	TC	69.3	65.0	62.7	61.2	58.9	56.6	54.3	52.7	50.1	47.8	45.2
	kW	14.0	15.8	16.8	17.5	18.5	19.6	20.8	21.5	22.7	23.9	25.2
4	TC	73.9	69.3	66.9	65.3	63.0	60.5	58.1	56.3	53.8	51.0	48.4
	kW	14.1	16.0	16.9	17.6	18.7	19.8	21.0	21.7	22.9	24.2	25.4
6	TC	78.7	73.8	71.3	69.6	67.1	64.5	61.8	60.0	57.2	54.4	51.7
	kW	14.3	16.1	17.1	17.8	18.9	20.0	21.1	21.9	23.1	24.4	25.7
8	TC	83.6	78.4	75.6	73.8	71.2	68.5	65.7	63.7	60.7	57.7	54.8
	kW	14.5	16.3	17.3	18.0	19.0	20.1	21.3	22.1	23.3	24.6	25.9
10	TC	88.5	82.9	79.9	78.1	75.3	72.4	69.5	67.4	64.3	61.3	58.0
	kW	14.6	16.4	17.4	18.1	19.2	20.3	21.5	22.3	23.5	24.8	26.1

## CIRCUIT B

SST (C)*		CONDENSER ENTERING-AIR TEMPERATURE (C)										
		21	27	30	32	35	38	41	43	46	49	52
0	TC	72.1	67.8	65.5	64.0	61.8	59.6	57.3	55.7	53.2	50.7	48.4
	kW	16.3	18.1	19.1	19.8	20.8	21.9	23.1	23.9	25.2	26.5	27.9
2	TC	77.0	72.3	69.9	68.3	66.0	63.5	61.1	59.4	56.7	54.1	51.5
	kW	16.7	18.5	19.5	20.1	21.2	22.3	23.5	24.3	25.5	26.8	28.2
4	TC	82.0	77.0	74.3	72.6	70.2	67.6	64.9	63.1	60.4	57.4	54.6
	kW	17.1	18.9	19.8	20.5	21.6	22.7	23.9	24.6	25.9	27.2	28.5
6	TC	86.9	81.7	78.8	77.0	74.4	71.5	68.8	66.8	63.9	60.7	57.9
	kW	17.5	19.3	20.2	20.9	22.0	23.1	24.2	25.0	26.3	27.5	28.9
8	TC	92.0	86.3	83.4	81.4	78.6	75.7	72.7	70.6	67.2	64.0	61.0
	kW	17.9	19.7	20.6	21.3	22.4	23.5	24.6	25.4	26.6	27.9	29.2
10	TC	97.1	91.0	87.9	85.7	82.9	79.7	76.2	74.2	70.9	67.2	64.1
	kW	18.3	20.1	21.1	21.7	22.8	23.9	25.0	25.8	27.0	28.3	29.6

### LEGEND

- kW — Compressor Power
- SST — Saturated Suction Temperature Entering Condensing Unit
- TC — Gross Cooling Capacity (kW)

### NOTES:

1. Ratings are based on 8.3 C superheat and use of R-410A refrigerant.
2. Ratings include suction line losses due to an accumulator.
3. Refer to Commercial Split Builder program for more detailed information.

\* 38AP units are not designed for refrigeration duty. Unit operational range should be reviewed to ensure that operation at full and part load conditions with saturated suction temperatures at or below 0° C are avoided. Operation below 0° C SST may result in ice build-up on evaporator coil, resulting in liquid flood-back and possible compressor failure.

### 38APD060 CONDENSING UNIT CIRCUIT RATINGS, 50 Hz SI CIRCUIT A

SST (C)*		CONDENSER ENTERING-AIR TEMPERATURE (C)										
		21	27	30	32	35	38	41	43	46	49	52
0	TC	72.7	68.1	66.2	64.7	62.6	60.4	58.2	56.8	54.6	52.3	49.8
	kW	15.1	16.8	17.7	18.3	19.4	20.5	21.6	22.4	23.7	24.9	26.4
2	TC	77.3	72.1	70.4	68.9	66.7	64.4	62.0	60.4	58.1	55.7	53.3
	kW	15.4	17.1	18.0	18.6	19.7	20.8	21.9	22.7	24.0	25.3	26.6
4	TC	82.2	77.3	74.9	73.2	70.8	68.4	65.9	64.4	61.8	59.4	56.6
	kW	15.7	17.4	18.3	19.0	20.0	21.1	22.2	23.0	24.3	25.6	26.9
6	TC	87.2	81.3	78.8	77.7	75.1	72.3	69.5	68.1	65.4	62.9	60.1
	kW	16.0	17.7	18.6	19.3	20.3	21.4	22.5	23.3	24.6	25.9	27.2
8	TC	93.0	85.5	82.0	80.7	77.6	75.8	73.0	71.9	68.8	66.2	62.9
	kW	16.4	18.1	19.0	19.6	20.6	21.8	22.9	23.7	24.9	26.2	27.5
10	TC	95.8	88.5	86.1	84.5	82.1	79.2	76.4	75.3	72.9	69.8	66.3
	kW	16.8	18.4	19.3	20.0	21.0	22.1	23.2	24.0	25.3	26.5	27.9

### CIRCUIT B

SST (C)*		CONDENSER ENTERING-AIR TEMPERATURE (C)										
		21	27	30	32	35	38	41	43	46	49	52
0	TC	85.0	79.6	77.4	75.6	73.1	70.6	68.0	66.4	63.6	61.0	57.9
	kW	18.9	21.0	22.2	23.0	24.3	25.6	27.0	28.0	29.6	31.1	32.8
2	TC	90.5	85.2	82.5	80.7	78.1	75.3	72.5	70.6	67.8	65.0	62.2
	kW	19.4	21.5	22.6	23.4	24.7	26.0	27.5	28.4	30.0	31.6	33.2
4	TC	96.4	90.7	87.8	85.9	83.1	80.2	77.2	75.4	72.4	69.5	66.0
	kW	19.8	21.9	23.1	23.9	25.1	26.5	27.9	28.9	30.4	32.0	33.6
6	TC	102.3	96.3	93.2	91.3	88.3	84.9	82.0	79.9	76.8	73.8	70.4
	kW	20.3	22.4	23.5	24.3	25.6	26.9	28.4	29.3	30.8	32.4	34.1
8	TC	108.5	101.6	98.8	96.7	93.1	90.1	86.5	84.3	81.2	77.3	74.1
	kW	20.8	22.9	24.0	24.8	26.1	27.4	28.8	29.8	31.3	32.9	34.5
10	TC	115.0	107.2	104.4	101.9	98.7	94.9	91.7	89.4	85.6	81.8	78.2
	kW	21.3	23.4	24.5	25.3	26.6	27.9	29.3	30.3	31.8	33.3	35.0

#### LEGEND

**kW** — Compressor Power  
**SST** — Saturated Suction Temperature Entering Condensing Unit  
**TC** — Gross Cooling Capacity (kW)

\* 38AP units are not designed for refrigeration duty. Unit operational range should be reviewed to ensure that operation at full and part load conditions with saturated suction temperatures at or below 0° C are avoided. Operation below 0° C SST may result in ice build-up on evaporator coil, resulting in liquid flood-back and possible compressor failure.

#### NOTES:

1. Ratings are based on 8.3 C superheat and use of R-410A refrigerant.
2. Ratings include suction line losses due to an accumulator.
3. Refer to Commercial Split Builder program for more detailed information.

# Performance data (cont)



## 38APD070 CONDENSING UNIT CIRCUIT RATINGS, 50 Hz SI CIRCUIT A

SST (C)*		CONDENSER ENTERING-AIR TEMPERATURE (C)										
		21	27	30	32	35	38	41	43	46	49	52
0	TC	94.2	88.1	85.9	83.7	80.8	76.9	74.5	71.5	69.0	64.4	62.2
	kW	21.1	23.7	25.1	26.1	27.6	29.2	30.8	31.9	33.5	35.2	36.9
2	TC	100.7	94.3	92.0	89.6	86.6	83.3	79.8	77.3	74.2	70.0	67.1
	kW	21.5	24.1	25.5	26.5	28.0	29.6	31.2	32.3	34.1	35.9	37.5
4	TC	107.3	100.5	98.1	95.6	92.4	89.0	85.3	82.7	79.5	74.7	72.0
	kW	21.9	24.5	26.0	27.0	28.5	30.1	31.7	32.8	34.6	36.5	38.1
6	TC	114.0	107.0	104.4	101.8	98.3	94.8	91.2	88.1	84.8	80.8	77.0
	kW	22.3	25.0	26.4	27.4	28.9	30.6	32.3	33.3	35.1	36.8	38.7
8	TC	121.6	113.5	110.8	108.0	104.4	100.7	96.6	93.8	90.1	86.1	82.0
	kW	22.7	25.4	26.9	27.9	29.4	31.0	32.7	33.9	35.6	37.4	39.3
10	TC	128.6	119.5	116.9	114.1	110.6	106.5	102.4	99.1	95.6	91.2	87.0
	kW	23.2	25.8	27.3	28.3	29.9	31.5	33.2	34.3	36.2	37.9	39.8

## CIRCUIT B

SST (C)*		CONDENSER ENTERING-AIR TEMPERATURE (C)										
		21	27	30	32	35	38	41	43	46	49	52
0	TC	96.5	90.3	87.9	85.0	82.6	78.6	76.1	73.0	70.5	65.8	63.4
	kW	21.0	23.6	25.0	26.0	27.5	29.0	30.6	31.7	33.4	35.1	36.7
2	TC	103.1	96.6	94.1	91.7	88.4	85.1	81.5	78.9	75.7	71.4	68.4
	kW	21.4	24.0	25.5	26.4	27.9	29.5	31.0	32.1	33.9	35.7	37.3
4	TC	109.9	103.0	100.4	97.8	94.4	90.9	87.1	84.4	81.1	76.3	73.4
	kW	21.8	24.5	25.9	26.9	28.4	29.9	31.5	32.6	34.4	36.2	37.9
6	TC	116.9	109.6	106.8	104.1	100.4	96.8	93.1	89.9	86.4	82.4	78.4
	kW	22.2	24.9	26.3	27.3	28.8	30.4	32.1	33.1	34.9	36.6	38.4
8	TC	124.7	116.3	113.4	110.4	106.6	102.7	98.6	95.7	91.8	87.7	83.4
	kW	22.7	25.3	26.8	27.8	29.3	30.9	32.5	33.7	35.4	37.2	39.0
10	TC	131.8	122.3	119.5	116.6	113.0	108.7	104.4	101.0	97.4	92.8	88.6
	kW	23.1	25.7	27.2	28.2	29.8	31.4	33.0	34.1	35.9	37.7	39.6

### LEGEND

- kW — Compressor Power
- SST — Saturated Suction Temperature Entering Condensing Unit
- TC — Gross Cooling Capacity (kW)

### NOTES:

1. Ratings are based on 8.3 C superheat and use of R-410A refrigerant.
2. Ratings include suction line losses due to an accumulator.
3. Refer to Commercial Split Builder program for more detailed information.

\* 38AP units are not designed for refrigeration duty. Unit operational range should be reviewed to ensure that operation at full and part load conditions with saturated suction temperatures at or below 0° C are avoided. Operation below 0° C SST may result in ice build-up on evaporator coil, resulting in liquid flood-back and possible compressor failure.



**38APD080 CONDENSING UNIT CIRCUIT RATINGS, 50 Hz SI**  
**CIRCUIT A**

SST (C)*		CONDENSER ENTERING-AIR TEMPERATURE (C)										
		21	27	30	32	35	38	41	43	46	49	52
0	TC	85.1	80.1	77.5	75.8	73.2	70.6	67.9	66.1	63.4	60.6	57.8
	kW	18.5	20.5	21.7	22.4	23.7	24.9	26.3	27.2	28.7	30.3	31.9
2	TC	90.9	85.5	82.8	80.9	78.1	75.3	72.4	70.5	67.6	64.6	61.6
	kW	18.9	20.9	22.1	22.8	24.1	25.3	26.7	27.6	29.1	30.6	32.2
4	TC	96.8	91.0	88.1	86.1	83.2	80.1	77.1	75.0	71.8	68.6	65.5
	kW	19.3	21.4	22.5	23.2	24.5	25.8	27.1	28.0	29.5	31.0	32.6
6	TC	102.8	96.7	93.5	91.4	88.2	85.0	81.7	79.5	76.1	72.7	69.3
	kW	19.8	21.8	22.9	23.7	24.9	26.2	27.5	28.4	29.9	31.4	33.0
8	TC	108.9	102.3	99.0	96.7	93.3	89.9	86.4	84.0	80.5	76.8	73.1
	kW	20.2	22.3	23.4	24.1	25.3	26.6	28.0	28.9	30.3	31.8	33.4
10	TC	115.0	108.1	104.5	102.1	98.5	94.8	91.1	88.6	84.8	80.9	76.9
	kW	20.7	22.8	23.8	24.6	25.8	27.1	28.4	29.3	30.7	32.2	33.8

**CIRCUIT B**

SST (C)*		CONDENSER ENTERING-AIR TEMPERATURE (C)										
		21	27	30	32	35	38	41	43	46	49	52
0	TC	127.2	119.8	116.0	113.4	109.6	105.6	101.6	99.0	94.9	90.7	86.5
	kW	27.4	30.6	32.4	33.7	35.6	37.7	39.8	41.3	43.6	46.0	48.5
2	TC	135.5	127.7	123.6	120.9	116.8	112.6	108.4	105.5	101.2	96.8	92.3
	kW	27.8	31.1	32.9	34.1	36.1	38.1	40.3	41.8	44.1	46.5	49.0
4	TC	144.0	135.6	131.3	128.4	124.1	119.6	115.1	112.1	107.4	102.7	98.0
	kW	28.3	31.6	33.4	34.6	36.5	38.6	40.7	42.2	44.5	46.9	49.4
6	TC	152.5	143.5	138.9	135.8	131.2	126.4	121.7	118.4	113.5	108.5	103.5
	kW	28.9	32.1	33.9	35.1	37.0	39.1	41.2	42.7	45.0	47.4	49.9
8	TC	160.8	151.2	146.3	143.0	138.1	133.1	128.0	124.6	119.4	114.2	108.8
	kW	29.4	32.6	34.4	35.6	37.5	39.6	41.7	43.2	45.4	47.8	50.3
10	TC	168.9	158.9	153.6	150.1	144.9	139.6	134.2	130.6	125.1	119.6	113.9
	kW	29.9	33.2	34.9	36.2	38.1	40.1	42.2	43.6	45.9	48.3	50.7

**LEGEND**

- kW** — Compressor Power
- SST** — Saturated Suction Temperature Entering Condensing Unit
- TC** — Gross Cooling Capacity (kW)

\* 38AP units are not designed for refrigeration duty. Unit operational range should be reviewed to ensure that operation at full and part load conditions with saturated suction temperatures at or below 0° C are avoided. Operation below 0° C SST may result in ice build-up on evaporator coil, resulting in liquid flood-back and possible compressor failure.

**NOTES:**

1. Ratings are based on 8.3 C superheat and use of R-410A refrigerant.
2. Ratings include suction line losses due to an accumulator.
3. Refer to Commercial Split Builder program for more detailed information.

# Performance data (cont)



## 38APD090 CONDENSING UNIT CIRCUIT RATINGS, 50 Hz SI CIRCUIT A

SST (C)*		CONDENSER ENTERING-AIR TEMPERATURE (C)										
		21	27	30	32	35	38	41	43	46	49	52
0	TC	109.8	103.1	99.8	97.6	94.4	91.0	87.5	85.1	81.6	78.0	73.8
	kW	22.1	24.9	26.5	27.6	29.3	31.1	33.0	34.3	36.3	38.3	40.3
2	TC	117.0	109.9	106.5	104.1	100.6	96.9	93.2	90.7	86.9	83.0	78.8
	kW	22.5	25.3	26.8	27.9	29.6	31.4	33.2	34.5	36.5	38.5	40.6
4	TC	124.9	116.7	113.0	110.5	106.7	102.9	98.9	96.2	92.1	88.1	83.5
	kW	22.9	25.6	27.2	28.2	29.9	31.7	33.5	34.8	36.8	38.8	40.9
6	TC	132.5	123.6	119.6	116.9	112.7	108.6	104.4	101.5	97.3	92.9	88.3
	kW	23.4	26.0	27.6	28.6	30.3	32.0	33.8	35.1	37.0	39.0	41.1
8	TC	140.1	130.6	126.1	123.2	118.7	114.2	109.7	106.7	102.1	97.5	92.7
	kW	23.8	26.5	28.0	29.0	30.6	32.3	34.1	35.4	37.3	39.3	41.4
10	TC	147.3	137.0	132.4	129.1	124.4	119.4	114.6	111.4	106.6	101.7	96.8
	kW	24.3	26.9	28.4	29.4	31.0	32.7	34.5	35.7	37.6	39.6	41.6

## CIRCUIT B

SST (C)*		CONDENSER ENTERING-AIR TEMPERATURE (C)										
		21	27	30	32	35	38	41	43	46	49	52
0	TC	127.1	119.8	116.0	113.5	109.5	105.6	101.6	99.2	94.8	90.7	86.4
	kW	27.4	30.6	32.4	33.7	35.6	37.7	39.8	41.3	43.6	46.0	48.5
2	TC	135.5	127.7	123.6	121.0	116.8	112.6	108.4	105.7	101.2	96.8	92.3
	kW	27.8	31.1	32.9	34.1	36.1	38.1	40.3	41.8	44.1	46.5	49.0
4	TC	144.0	135.6	131.3	128.6	124.1	119.6	115.1	112.4	107.4	102.7	97.9
	kW	28.3	31.6	33.4	34.6	36.5	38.6	40.7	42.2	44.5	46.9	49.4
6	TC	152.4	143.5	138.9	136.0	131.2	126.5	121.7	118.8	113.6	108.6	103.4
	kW	28.8	32.1	33.9	35.1	37.0	39.1	41.2	42.7	45.0	47.4	49.9
8	TC	160.8	151.3	146.4	143.4	138.2	133.2	128.1	125.1	119.5	114.3	108.8
	kW	29.4	32.6	34.4	35.6	37.5	39.6	41.7	43.2	45.4	47.8	50.3
10	TC	168.9	158.8	153.7	150.4	144.9	139.6	134.2	131.0	125.1	119.6	113.9
	kW	30.0	33.2	34.9	36.2	38.1	40.1	42.2	43.7	45.9	48.3	50.7

### LEGEND

- kW** — Compressor Power
- SST** — Saturated Suction Temperature Entering Condensing Unit
- TC** — Gross Cooling Capacity (kW)

### NOTES:

1. Ratings are based on 8.3 C superheat and use of R-410A refrigerant.
2. Ratings include suction line losses due to an accumulator.
3. Refer to Commercial Split Builder program for more detailed information.

\* 38AP units are not designed for refrigeration duty. Unit operational range should be reviewed to ensure that operation at full and part load conditions with saturated suction temperatures at or below 0° C are avoided. Operation below 0° C SST may result in ice build-up on evaporator coil, resulting in liquid flood-back and possible compressor failure.

### 38APD100 CONDENSING UNIT CIRCUIT RATINGS, 50 Hz SI CIRCUIT A

SST (C)*		CONDENSER ENTERING-AIR TEMPERATURE (C)										
		21	27	30	32	35	38	41	43	46	49	52
0	TC	130.5	123.1	119.3	116.7	112.8	108.9	104.9	102.2	98.1	93.9	89.6
	kW	28.2	31.4	33.1	34.3	36.2	38.3	40.4	41.9	44.2	46.6	49.1
2	TC	139.6	131.6	127.6	124.8	120.7	116.5	112.2	109.4	105.0	100.5	95.9
	kW	28.8	32.0	33.7	35.0	36.9	38.9	41.0	42.5	44.8	47.1	49.6
4	TC	148.0	140.4	136.1	133.2	128.8	124.3	119.8	116.7	112.1	107.3	102.4
	kW	30.0	32.6	34.4	35.6	37.5	39.5	41.6	43.1	45.4	47.8	50.2
6	TC	158.4	149.4	144.8	141.7	137.0	132.3	127.5	124.2	119.3	114.2	109.0
	kW	30.1	33.3	35.0	36.2	38.1	40.2	42.3	43.7	46.0	48.4	50.8
8	TC	168.2	158.6	153.7	150.4	145.4	140.4	135.3	131.8	126.5	121.2	115.5
	kW	30.8	34.0	35.7	36.9	38.8	40.8	42.9	44.4	46.6	49.0	51.5
10	TC	178.1	167.9	162.7	159.2	153.9	148.5	143.1	139.5	133.8	128.1	122.1
	kW	31.5	34.7	36.4	37.6	39.5	41.5	43.6	45.1	47.3	49.7	52.1

### CIRCUIT B

SST (C)*		CONDENSER ENTERING-AIR TEMPERATURE (C)										
		21	27	30	32	35	38	41	43	46	49	52
0	TC	130.4	123.0	119.2	116.6	112.7	108.8	104.8	102.1	98.0	93.8	89.5
	kW	28.1	31.3	33.1	34.3	36.2	38.2	40.3	41.8	44.1	46.5	49.0
2	TC	139.4	131.5	127.4	124.7	120.6	116.4	112.2	109.3	104.9	100.5	95.9
	kW	28.7	31.9	33.7	34.9	36.8	38.8	40.9	42.4	44.7	47.1	49.6
4	TC	149.0	140.3	136.0	133.1	128.7	124.3	119.7	116.7	112.0	107.3	102.4
	kW	30.0	32.5	34.3	35.5	37.4	39.5	41.6	43.0	45.3	47.7	50.2
6	TC	158.3	149.3	144.7	141.6	136.9	132.2	127.4	124.2	119.3	114.2	109.0
	kW	30.0	33.2	35.0	36.2	38.1	40.1	42.2	43.7	45.9	48.3	50.8
8	TC	168.0	158.4	153.6	150.3	145.3	140.3	135.2	131.8	126.5	121.2	115.6
	kW	30.7	33.9	35.6	36.8	38.7	40.8	42.9	44.3	46.6	49.0	51.4
10	TC	177.9	167.7	162.5	159.0	153.8	148.4	143.0	139.4	133.8	128.1	122.1
	kW	31.4	34.6	36.4	37.6	39.5	41.4	43.5	45.0	47.3	49.6	52.1

#### LEGEND

**kW** — Compressor Power  
**SST** — Saturated Suction Temperature Entering Condensing Unit  
**TC** — Gross Cooling Capacity (kW)

#### NOTES:

1. Ratings are based on 8.3 C superheat and use of R-410A refrigerant.
2. Ratings include suction line losses due to an accumulator.
3. Refer to Commercial Split Builder program for more detailed information.

\* 38AP units are not designed for refrigeration duty. Unit operational range should be reviewed to ensure that operation at full and part load conditions with saturated suction temperatures at or below 0° C are avoided. Operation below 0° C SST may result in ice build-up on evaporator coil, resulting in liquid flood-back and possible compressor failure.

# Performance data (cont)



## 38APD115 CONDENSING UNIT CIRCUIT RATINGS, 50 Hz SI

### CIRCUIT A

SST (C)*		CONDENSER ENTERING-AIR TEMPERATURE (C)										
		21	27	30	32	35	38	41	43	46	49	52
0	TC	129.2	121.8	118.1	115.6	111.7	107.8	104.0	101.1	97.3	93.1	88.9
	kW	28.0	31.4	33.2	34.5	36.5	38.6	40.8	42.3	44.7	47.2	49.7
2	TC	138.3	130.5	126.5	123.8	119.7	115.6	111.4	108.4	104.3	99.9	95.4
	kW	28.5	31.9	33.7	35.0	37.0	39.1	41.3	42.8	45.2	47.6	50.2
4	TC	147.7	139.4	135.2	132.3	127.9	123.5	119.0	115.9	111.5	106.7	101.9
	kW	29.0	32.4	34.2	35.5	37.5	39.6	41.8	43.3	45.6	48.1	50.6
6	TC	157.3	148.5	143.9	140.8	136.2	131.5	126.8	123.5	118.7	113.7	108.4
	kW	29.5	32.9	34.7	36.0	38.0	40.0	42.2	43.7	46.1	48.5	51.1
8	TC	166.9	157.6	152.7	149.4	144.5	139.5	134.5	130.9	125.8	120.5	114.9
	kW	30.1	33.4	35.2	36.5	38.4	40.5	42.7	44.2	46.5	49.0	51.5
10	TC	176.8	166.5	161.3	157.9	152.7	147.4	142.0	138.1	132.8	127.0	121.1
	kW	30.7	33.9	35.7	37.0	39.0	41.0	43.2	44.7	47.0	49.4	51.9

### CIRCUIT B

SST (C)*		CONDENSER ENTERING-AIR TEMPERATURE (C)										
		21	27	30	32	35	38	41	43	46	49	52
0	TC	163.6	153.2	148.3	144.8	139.6	134.3	129.3	125.4	120.5	115.1	109.7
	kW	37.0	41.5	44.0	45.7	48.3	51.1	54.0	56.0	59.2	62.5	65.8
2	TC	175.6	164.6	159.2	155.5	149.9	144.4	138.7	134.9	129.4	123.8	117.9
	kW	37.7	42.2	44.7	46.4	49.0	51.8	54.8	56.8	59.9	63.2	66.5
4	TC	187.9	176.2	170.5	166.5	160.6	154.6	148.6	144.4	138.7	132.5	126.2
	kW	38.4	42.9	45.4	47.1	49.8	52.6	55.5	57.5	60.6	63.9	67.3
6	TC	200.6	188.7	182.0	177.8	171.5	165.1	158.7	154.3	148.1	141.4	134.7
	kW	39.2	43.7	46.1	47.9	50.5	53.3	56.2	58.2	61.3	64.6	67.9
8	TC	213.5	201.0	193.7	189.2	182.5	175.7	168.9	164.2	157.5	150.5	143.1
	kW	40.0	44.5	46.9	48.6	51.3	54.0	56.9	58.9	62.0	65.3	68.6
10	TC	227.4	213.0	205.4	200.7	193.5	186.3	179.2	174.0	166.9	159.4	151.4
	kW	40.9	45.3	47.7	49.4	52.0	54.8	57.7	59.6	62.7	66.0	69.2

#### LEGEND

- kW** — Compressor Power
- SST** — Saturated Suction Temperature Entering Condensing Unit
- TC** — Gross Cooling Capacity (kW)

#### NOTES:

1. Ratings are based on 8.3 C superheat and use of R-410A refrigerant.
2. Ratings include suction line losses due to an accumulator.
3. Refer to Commercial Split Builder program for more detailed information.

\* 38AP units are not designed for refrigeration duty. Unit operational range should be reviewed to ensure that operation at full and part load conditions with saturated suction temperatures at or below 0° C are avoided. Operation below 0° C SST may result in ice build-up on evaporator coil, resulting in liquid flood-back and possible compressor failure.

### 38APD130 CONDENSING UNIT CIRCUIT RATINGS, 50 Hz SI

#### CIRCUIT A

SST (C)*		CONDENSER ENTERING-AIR TEMPERATURE (C)										
		21	27	30	32	35	38	41	43	46	49	52
0	TC	129.3	121.8	118.1	116.2	111.7	107.8	103.8	101.0	97.0	92.9	88.0
	kW	28.1	31.5	33.4	34.7	36.7	38.8	41.0	42.5	44.9	47.4	49.9
2	TC	138.5	130.5	126.4	124.5	119.7	115.5	111.3	109.3	104.1	99.6	94.9
	kW	28.7	32.0	33.9	35.2	37.2	39.3	41.5	43.1	45.4	47.9	50.4
4	TC	146.2	139.5	135.0	133.2	128.0	123.5	118.9	116.9	111.2	106.4	101.5
	kW	29.0	32.5	34.4	35.7	37.7	39.8	42.0	43.5	45.9	48.3	50.9
6	TC	157.5	148.5	144.2	141.8	136.1	131.5	126.6	124.5	118.4	113.3	110.1
	kW	29.7	33.1	34.9	36.2	38.2	40.3	42.5	43.9	46.3	48.8	51.2
8	TC	167.5	157.7	152.9	150.5	144.4	139.4	134.3	132.1	127.4	120.4	116.5
	kW	30.3	33.6	35.4	36.7	38.7	40.8	42.9	44.4	46.8	49.3	51.6
10	TC	177.3	166.8	162.9	159.0	154.3	149.2	142.2	139.6	134.5	126.8	123.1
	kW	30.9	34.2	36.1	37.3	39.3	41.4	43.4	45.0	47.2	49.7	52.1

#### CIRCUIT B

SST (C)*		CONDENSER ENTERING-AIR TEMPERATURE (C)										
		21	27	30	32	35	38	41	43	46	49	52
0	TC	205.3	192.7	187.0	184.0	176.6	170.2	163.7	159.4	152.9	146.4	139.3
	kW	45.5	50.6	53.3	55.3	58.2	61.4	64.6	66.9	70.4	74.2	78.0
2	TC	220.0	206.8	200.3	197.3	189.3	182.5	175.8	172.7	164.3	156.9	149.5
	kW	46.5	51.6	54.3	56.3	59.2	62.4	65.7	68.0	71.5	75.2	79.0
4	TC	235.4	221.3	214.1	211.2	202.5	195.1	187.8	184.7	175.4	167.6	160.0
	kW	47.5	52.6	55.4	57.4	60.3	63.4	66.7	68.9	72.5	76.2	80.0
6	TC	251.5	236.1	229.0	225.2	215.5	208.0	200.2	196.9	187.0	178.7	173.6
	kW	48.6	53.7	56.5	58.5	61.3	64.5	67.8	70.0	73.6	77.2	80.9
8	TC	267.8	251.5	243.4	239.6	229.1	221.0	212.4	209.2	201.8	189.8	184.3
	kW	49.8	54.8	57.6	59.6	62.4	65.6	68.9	71.1	74.7	78.3	81.9
10	TC	284.2	267.0	260.5	254.0	246.3	233.5	228.8	219.3	213.7	200.1	195.2
	kW	50.9	56.0	59.0	60.8	63.8	66.7	70.2	72.2	75.8	79.4	83.1

#### LEGEND

- kW** — Compressor Power
- SST** — Saturated Suction Temperature Entering Condensing Unit
- TC** — Gross Cooling Capacity (kW)

#### NOTES:

1. Ratings are based on 8.3 C superheat and use of R-410A refrigerant.
2. Ratings include suction line losses due to an accumulator.
3. Refer to Commercial Split Builder program for more detailed information.

\* 38AP units are not designed for refrigeration duty. Unit operational range should be reviewed to ensure that operation at full and part load conditions with saturated suction temperatures at or below 0° C are avoided. Operation below 0° C SST may result in ice build-up on evaporator coil, resulting in liquid flood-back and possible compressor failure.

# Typical piping and wiring



## ROOFTOP INSTALLATION - 38AP UNITS

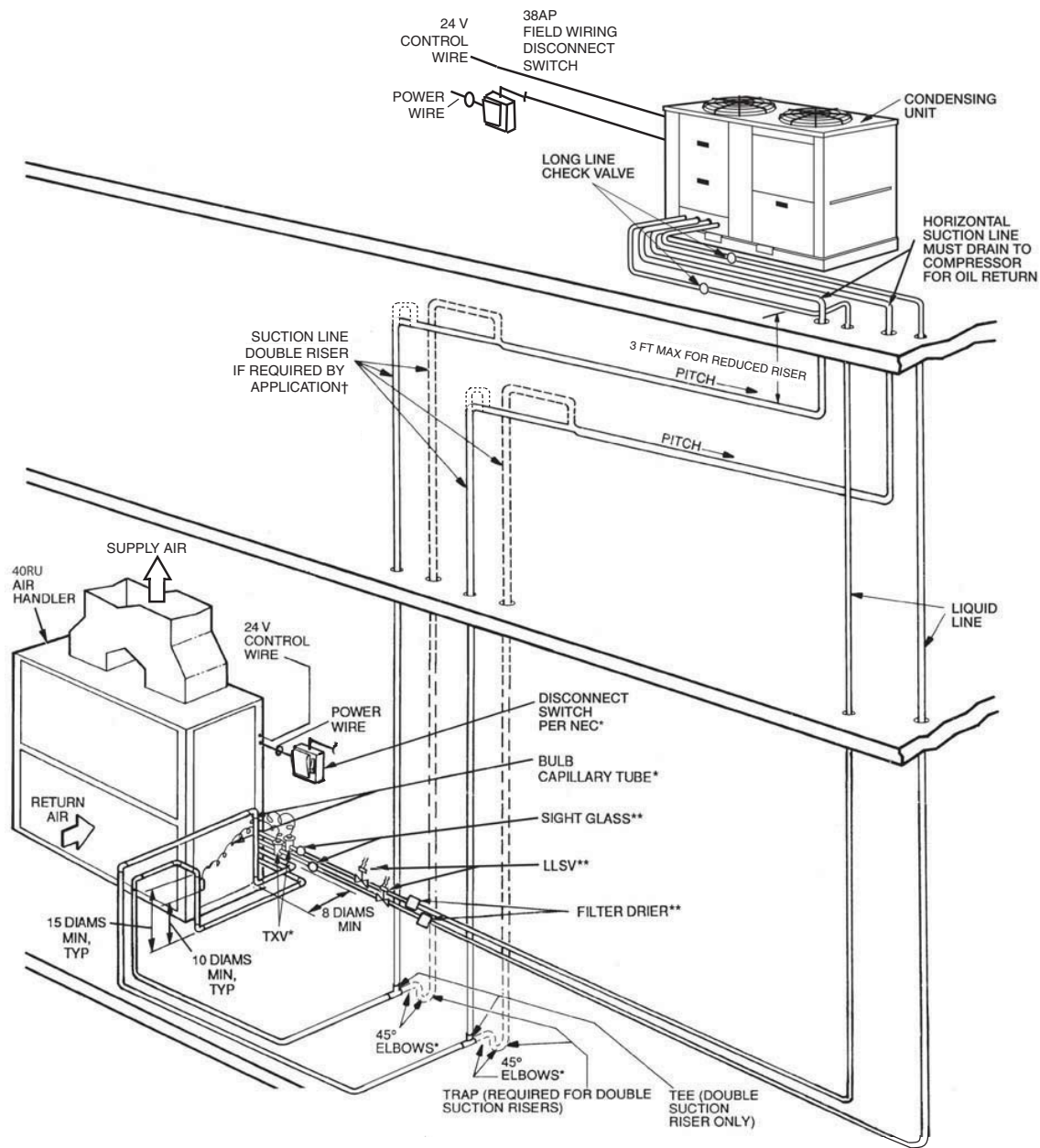

### LEGEND

- LLSV** — Liquid Line Solenoid Valve
- NEC** — National Electrical Code
- TXV** — Thermostatic Expansion Valve
- Piping
- Double Riser Piping (if required)

\*Field supplied.

†If double suction riser is required for piping system, size pipe diameter of 3 ft (0.9 m) (maximum) riser according to application data.

\*\*Field supplied. See Refrigerant Specialties Part Numbers table on page 74.

### NOTES:

1. All piping must follow standard refrigerant piping techniques. Refer to Carrier System Design Manual for details.
2. All wiring must comply with the applicable local and national codes.
3. Wiring and piping shown are general points-of-connection guides only and are not intended for, or to include all details for, a specific installation.
4. Install field-supplied disconnect switch in accordance with all local and national electrical codes.
5. Liquid line solenoid valves (solenoid drop control) are recommended on all applications to prevent refrigerant migration to the compressor. Liquid line solenoid valves are required on applications having 75 ft (23 m) or greater pipe length or if the evaporator surface area exceeds limits defined in the installation instructions.
6. Factory-supplied accumulator not shown.
7. Dual-circuit piping shown. Single-circuit piping is similar but would only have one suction line and one liquid line.
8. A field-supplied, 5 to 15% bleed port TXV is required for every application.
9. Sight glass, LLSV, and filter drier are field supplied.
10. Long line length check valves are required for liquid line installation on all linear line length applications of more than 100 ft (30.5 m). For any 025-030 size dual-circuit unit application where evaporator is located higher than the condensing unit, check valves are required for linear line length above 55 ft (16.8 m).
11. Do not use soft solder.
12. Maximum vertical separation between evaporator and condensing unit is 75 ft (22.8 m).



### GROUND LEVEL INSTALLATION — 38AP UNITS

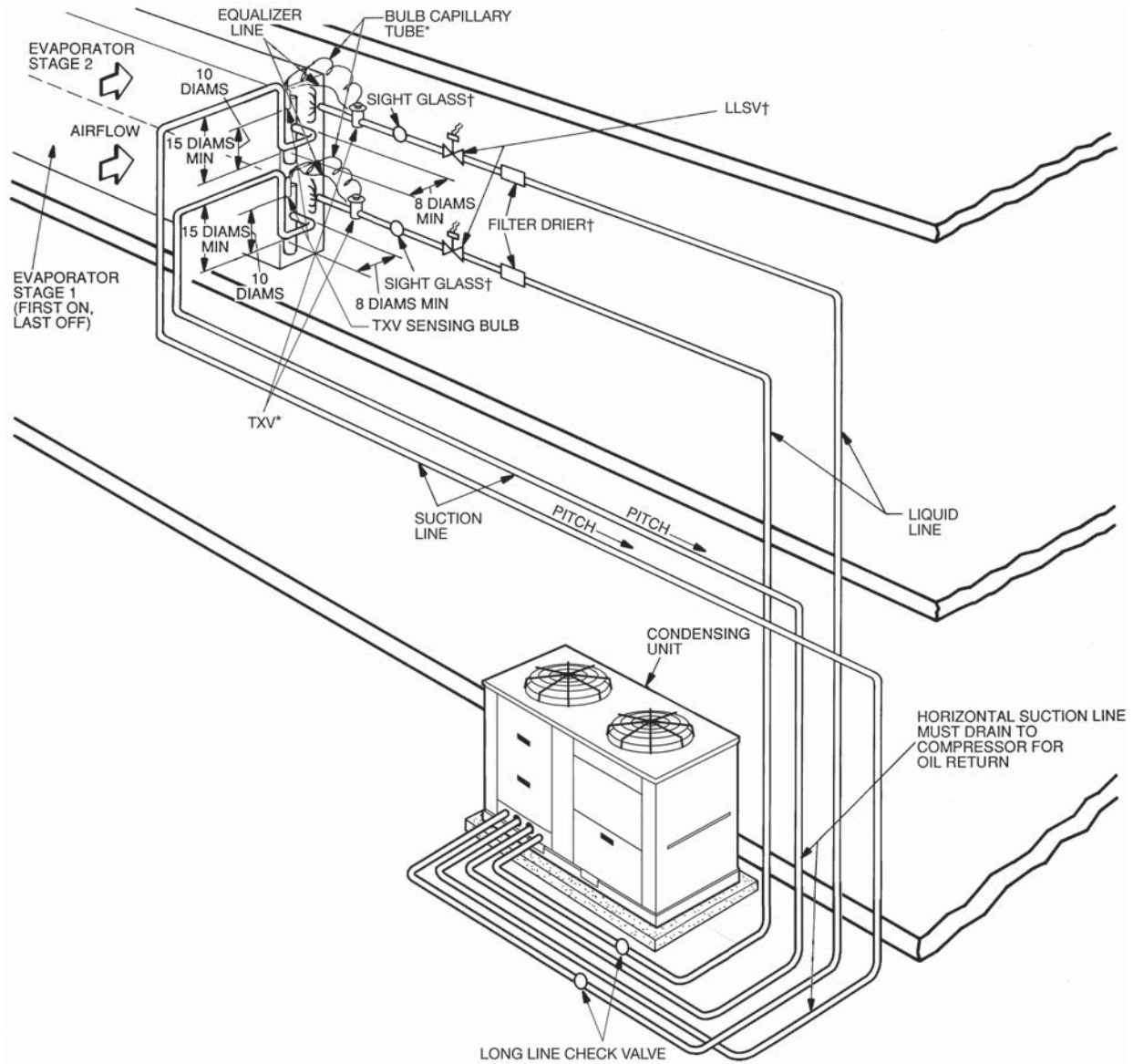

**LEGEND**

- LLSV** — Liquid Line Solenoid Valve
- NEC** — National Electrical Code
- TXV** — Thermostatic Expansion Valve
- Piping

\*Field supplied.

†Field supplied. See Refrigerant Specialties Part Numbers table on page 74.

**NOTES:**

1. All piping must follow standard refrigerant piping techniques. Refer to Carrier System Design Manual for details.
2. All wiring must comply with the applicable local and national codes.
3. Wiring and piping shown are general points-of-connection guides only and are not intended for, or to include all details for, a specific installation.
4. Install field-supplied disconnect switch in accordance with all local and national electrical codes.
5. Liquid line solenoid valves (solenoid drop control) are recommended on all applications to prevent refrigerant migration to the compressor. Liquid line solenoid valves are required on applications having 75 ft (23 m) or greater pipe length or if the evaporator surface area exceeds limits defined in the installation instructions.
6. Factory-supplied accumulator not shown.
7. Dual-circuit piping shown. Single-circuit piping is similar but would only have one suction line and one liquid line.
8. A field-supplied, 5 to 15% bleed port TXV is required for every application.
9. Sight glass, LLSV, and filter drier are field supplied.
10. Long line length check valves are required for liquid line installation on all linear line length applications of more than 100 ft (30.5 m). For any 025-030 size dual-circuit unit application where evaporator is located higher than the condensing unit, check valves are required for linear line length above 55 ft (16.8 m).
11. Do not use soft solder.
12. Maximum vertical separation between evaporator and condensing unit is 75 ft (22.8 m).

# Typical piping and wiring (cont)



## REFRIGERANT SPECIALTIES PART NUMBERS

38APS UNIT SIZE	CIRCUIT A						Filter Drier Core
	Tons	LL Size (in.)	LLSV	LLSV Coil 24-v, 50/60 Hz	Sight Glass	Filter Drier	
025	24.0	5/8 7/8	EF680028 EF680029	EF680032 EF680032	KM680005 KM680006	KH680002 KH680003	KH680008 KH680008
027	26.7	5/8 7/8	EF680028 EF680029	EF680032 EF680032	KM680005 KM680006	KH680002 KH680003	KH680008 KH680008
030	31.1	5/8 7/8 1 1/8	EF680028 EF680029 EF680030	EF680032 EF680032	KM680005 KM680006	KH680002 KH680003	KH680008 KH680008
040	39.8	5/8 7/8 1 1/8	EF680028 EF680029 EF680030	EF680032 EF680032	KM680005 KM680007	KH680003* KH680003 KH680004	KH680008 KH680008 KH680008
050	48.1	7/8 1 1/8	EF680029 EF680030	EF680032 EF680032	KM680006 KM680007	KH680004 KH680004	KH680008 KH680008
065	59.6	7/8 1 1/8 1 3/8	EF680029 EF680030 EF680038	EF680032 EF680032	KM680006 KM680007	KH680003 KH680004	KH680008 KH680008 KH680008

38APD UNIT SIZE	CIRCUIT B													
	Tons	LL Size (in.)	LLSV	LLSV Coil 24-v, 50/60 Hz	Sight Glass	Filter Drier	Filter Core	Tons	LL Size (in.)	LLSV	LLSV Coil 24-v, 50/60 Hz	Sight Glass	Filter Drier	Filter Core
025	12.0	1/2 5/8	EF680031 EF680028	EF680032 EF680032	KM680004 KM680005	KH680001 KH680002	— KH680008	12.0	1/2 5/8	EF680031 EF680028	EF680032 EF680032	KM680004 KM680005	KH680001 KH680002	— KH680008
027	13.3	1/2 5/8	EF680031 EF680028	EF680032 EF680032	KM680004 KM680005	KH680001 KH680002	— KH680008	13.3	1/2 5/8	EF680031 EF680028	EF680032 EF680032	KM680004 KM680005	KH680001 KH680002	— KH680008
030	15.6	1/2 5/8 7/8	EF680031 EF680028 EF680029	EF680032 EF680032 EF680032	KM680004 KM680005 KM680006	KH680001 KH680002 KH680003	— KH680008 KH680008	15.6	1/2 5/8 7/8	EF680031 EF680028 EF680029	EF680032 EF680032 EF680032	KM680004 KM680005 KM680006	KH680001 KH680002 KH680003	— KH680008 KH680008
040	21.0	5/8 7/8	EF680028 EF680029	EF680032 EF680032	KM680005 KM680006	KH680002 KH680003	— KH680008	18.2	1/2 5/8 7/8	EF680028 EF680029	EF680032 EF680032	KM680004 KM680005	KH680001 KH680002	— KH680008
050	23.8	5/8 7/8	EF680028 EF680029	EF680032 EF680032	KM680005 KM680006	KH680002 KH680003	— KH680008	26.3	5/8 7/8	EF680028 EF680029	EF680032 EF680032	KM680005 KM680006	KH680001 KH680002	— KH680008
060	26.8	5/8 7/8	EF680028 EF680029	EF680032 EF680032	KM680005 KM680006	KH680002 KH680003	— KH680008	31.5	5/8 7/8 1 1/8	EF680028 EF680029	EF680032 EF680032	KM680005 KM680006	KH680001 KH680002	— KH680008
070	31.8	5/8 7/8 1 1/8	EF680028 EF680029 EF680030	EF680032 EF680032 EF680032	KM680005 KM680006 KM680007	KH680002 KH680003 KH680004	— KH680008 KH680008	35.5	5/8 7/8 1 1/8	EF680028 EF680029	EF680032 EF680032	KM680005 KM680006	KH680001 KH680002	— KH680008
080	31.3	5/8 7/8 1 1/8	EF680028 EF680029 EF680030	EF680032 EF680032 EF680032	KM680005 KM680006 KM680007	KH680002 KH680003 KH680004	— KH680008 KH680008	46.7	5/8 7/8 1 1/8	EF680028 EF680029	EF680032 EF680032	KM680005 KM680006	KH680001 KH680002	— KH680008
090	40.3	5/8 7/8 1 1/8	EF680028 EF680029 EF680030	EF680032 EF680032 EF680032	KM680005 KM680006 KM680007	KH680002 KH680003 KH680004	— KH680008 KH680008	47.1	7/8 1 1/8	EF680029 EF680030	EF680032 EF680032	KM680006 KM680007	KH680001 KH680002	— KH680008
100	48.0	1 1/8 1 3/8	EF680029 EF680030	EF680032 EF680032	KM680006 KM680007	KH680003 KH680004	— KH680008	48.0	7/8 1 1/8	EF680029 EF680030	EF680032 EF680032	KM680006 KM680007	KH680001 KH680002	— KH680008
115	48.0	7/8 1 1/8	EF680029 EF680030	EF680032 EF680032	KM680006 KM680007	KH680003 KH680004	— KH680008	62.4	7/8 1 1/8 1 3/8	EF680029 EF680030	EF680032 EF680032	KM680006 KM680007	KH680001 KH680002	— KH680008
130	48.0	7/8 1 1/8	EF680029 EF680030	EF680032 EF680032	KM680006 KM680007	KH680003 KH680004	— KH680008	77.1	7/8 1 1/8 1 3/8	EF680029 EF680030	EF680032 EF680032	KM680006 KM680007	KH680001 KH680002	— KH680008

**LEGEND**  
 LLSV — Liquid Line  
 LLSV — Liquid Line Solenoid Valve

\*Bushing required to fit 5/8 in. line.

1. Filter driers have been sized based upon 1 to 2 psig (250 to 500 Pa) pressure drop clean in accordance with AHRI Standard 710. Filter drier KH680001 is a hermetically sealed beaded drier that does not require a replaceable core. All other filter driers listed require the filter core KH680008, which is replaceable and sold separately (not included).  
 2. Thermostatic expansion valve (TXV) is provided with all 40RU fan coil units. Contact your Carrier representative for appropriate TXV size.

3. All pipe sizes are OD inches. Equivalent sizes in millimeters follow:

in.	mm
1/2	12.7
5/8	15.9
7/8	22.2
1 1/8	28.6
1 3/8	34.9

4. Liquid line solenoid valves (solenoid drop control) are recommended on all applications to prevent refrigerant migration to the compressor. Liquid line solenoid valves are required on applications having 75 ft (23 m) or greater pipe length or if the evaporator surface area exceeds limits defined in the installation instructions.

## 38APS ELECTRICAL DATA — SINGLE POINT STANDARD FAN

38APS UNIT SIZE	V-Ph-Hz	SUPPLY VOLTAGE		COMPRESSOR			CONDENSER FAN		MCA	MOCP	REC FUSE	ICF
		Min	Max	Qty	RLA	LRA	Total Qty	FLA				
025	208/230-3-60	187	254	2	48.1	245	2	6.6	121.4	150	150	306.3
	380-3-60	342	418		23.7	145		3.9	61.1	80	70	176.5
	460-3-60	414	506		18.6	125		3.3	48.5	60	60	150.2
	575-3-60	518	632		14.7	100		2.6	38.3	50	45	119.9
	380/415-3-50	342	440		18.6	118		3.3	48.5	60	60	143.2
027	208/230-3-60	187	254	2	51.3	300	2	6.6	128.6	175	150	364.5
	380-3-60	342	418		26.9	139		3.9	68.3	90	80	173.7
	460-3-60	414	506		23.1	150		3.3	58.6	80	70	179.7
	575-3-60	518	632		19.9	109		2.6	50.0	60	60	134.1
	380/415-3-50	342	440		23.1	140		3.3	58.6	80	70	169.7
030	208/230-3-60	187	254	2	55.8	340	2	6.6	138.8	175	175	409.0
	380-3-60	342	418		34.0	196		3.9	84.3	110	100	237.8
	460-3-60	414	506		26.9	179		3.3	67.1	90	80	212.5
	575-3-60	518	632		23.7	132		2.6	58.5	80	70	160.9
	380/415-3-50	342	440		26.9	174		3.3	67.1	90	80	207.5
040	208/230-3-60	187	254	3	51.3	300	3	6.6	186.5	225	200	422.4
	380-3-60	342	418		26.9	139		3.9	99.1	125	110	204.5
	460-3-60	414	506		23.1	150		3.3	85.0	100	100	206.1
	575-3-60	518	632		19.9	109		2.6	72.5	90	80	156.6
	380/415-3-50	342	440		23.1	140		3.3	85.0	100	100	196.1
050	208/230-3-60	187	254	3	55.8	340	3	6.6	201.2	250	225	471.4
	380-3-60	342	418		34.0	196		3.9	122.2	150	150	275.7
	460-3-60	414	506		26.9	179		3.3	97.3	110	110	242.7
	575-3-60	518	632		23.7	132		2.6	84.8	100	100	187.2
	380/415-3-50	342	440		26.9	174		3.3	97.3	110	110	237.7
065	208/230-3-60	187	254	3	72.4	538	4	6.6	261.7	300	300	709.2
	380-3-60	342	418		35.3	290		3.9	130.3	150	150	376.2
	460-3-60	414	506		30.8	229		3.3	113.3	125	125	303.8
	575-3-60	518	632		25.0	180		2.6	91.7	110	100	240.4
	380/415-3-50	342	440		30.8	229		3.3	113.3	125	125	303.8

## 38APS ELECTRICAL DATA — SINGLE POINT LOW SOUND FAN

38APS UNIT SIZE	V-Ph-Hz	SUPPLY VOLTAGE		COMPRESSOR			CONDENSER FAN		MCA	MOCP	REC FUSE	ICF
		Min	Max	Qty	RLA	LRA	Total Qty	FLA				
025	208/230-3-60	187	254	2	48.1	245	2	6.0	120.2	150	150	305.1
	380-3-60	342	418		23.7	145		3.9	61.1	80	70	176.5
	460-3-60	414	506		18.6	125		2.9	47.7	60	60	149.4
	575-3-60	518	632		14.7	100		2.4	37.9	50	45	119.5
	380/415-3-50	342	440		18.6	118		2.9	47.7	60	60	142.4
027	208/230-3-60	187	254	2	51.3	300	2	6.0	127.4	175	150	363.3
	380-3-60	342	418		26.9	139		3.9	68.3	90	80	173.7
	460-3-60	414	506		23.1	150		2.9	57.8	80	70	178.9
	575-3-60	518	632		19.9	109		2.4	49.6	60	60	133.7
	380/415-3-50	342	440		23.1	140		2.9	57.8	80	70	168.9
030	208/230-3-60	187	254	2	55.8	340	2	6.0	137.6	175	175	407.8
	380-3-60	342	418		34.0	196		3.9	84.3	110	100	237.8
	460-3-60	414	506		26.9	179		2.9	66.3	90	80	211.7
	575-3-60	518	632		23.7	132		2.4	58.1	80	70	160.5
	380/415-3-50	342	440		26.9	174		2.9	66.3	90	80	206.7
040	208/230-3-60	187	254	3	51.3	300	3	6.0	184.7	225	200	420.6
	380-3-60	342	418		26.9	139		3.9	99.1	125	110	204.5
	460-3-60	414	506		23.1	150		2.9	83.8	100	100	204.9
	575-3-60	518	632		19.9	109		2.4	71.9	90	80	156.0
	380/415-3-50	342	440		23.1	140		2.9	83.8	100	100	194.9
050	208/230-3-60	187	254	3	55.8	340	3	6.0	199.4	250	225	469.6
	380-3-60	342	418		34.0	196		3.9	122.2	150	150	275.7
	460-3-60	414	506		26.9	179		2.9	96.1	110	110	241.5
	575-3-60	518	632		23.7	132		2.4	84.2	100	100	186.6
	380/415-3-50	342	440		26.9	174		2.9	96.1	110	110	236.5
065	208/230-3-60	187	254	3	72.4	538	4	6.0	259.3	300	300	706.8
	380-3-60	342	418		35.3	290		3.9	130.3	150	150	376.2
	460-3-60	414	506		30.8	229		2.9	111.7	125	125	302.2
	575-3-60	518	632		25.0	180		2.4	90.9	110	100	239.6
	380/415-3-50	342	440		30.8	229		2.9	111.7	125	125	302.2

### LEGEND

<b>FLA</b>	— Full Load Amps
<b>ICF</b>	— Maximum Instantaneous Current Flow
<b>LRA</b>	— Locked Rotor Amps
<b>MCA</b>	— Minimum Circuit Amps
<b>MOCP</b>	— Maximum Overcurrent Protection
<b>RLA</b>	— Rated Load Amps

### NOTES:

- Units are suitable for use on electrical systems where voltage supplied to the unit terminals is not below or above the listed minimum and maximum limits. Maximum allowable phase imbalance is: voltage 2%; amps 10%.
- All units or modules have single point primary power connection. Main power must be supplied from a field-supplied disconnect.
- For MCA that is less than or equal to 380 amps, 3 conductors are required. For MCA between 381 and 760 amps, 6 conductors are required. Calculation of conductors required is based on 75 C copper wire.

- Wiring for main field supply must be rated 75 C. Use copper conductors only.
  - Incoming wire size range for terminal block with MCA up to 175 amps is 14 AWG (American Wire Gauge) to 2/0.
  - Incoming wire size range for terminal block with MCA from 175.1 amps to 420 amps is 2 AWG to 600 kcmil.
  - Incoming wire size range for non-fused disconnect with MCA up to 100 amps is 14 AWG to 1/0.
  - Incoming wire size range for non-fused disconnect with MCA from 100.1 amps to 200 amps is 6 AWG to 350 kcmil.
  - Incoming wire size range for non-fused disconnect with MCA from 200.1 amps to 450 amps is 3/0 to 500 kcmil.



# Electrical data (cont)



## 38APD ELECTRICAL DATA — SINGLE POINT STANDARD FAN

38APD UNIT SIZE	V-Ph-Hz	SUPPLY VOLTAGE		COMPRESSOR						CONDENSER FAN		MCA	MOCP	REC FUSE	ICF
				CIRCUIT A			CIRCUIT B			Total Qty	FLA				
		Min	Max	Qty	RLA	LRA	Qty	RLA	LRA						
025	208/230-3-60	187	254	1	48.1	245	1	48.1	245	2	6.6	121.4	150	150	306.3
	380-3-60	342	418		23.7	145		23.7	145		3.9	61.1	80	70	176.5
	460-3-60	414	506		18.6	125		18.6	125		3.3	48.5	60	60	150.2
	575-3-60	518	632		14.7	100		14.7	100		2.6	38.3	50	45	119.9
	380/415-3-50	342	440		18.6	118		18.6	118		3.3	48.5	60	60	143.2
027	208/230-3-60	187	254	1	51.3	300	1	51.3	300	2	6.6	128.6	175	150	364.5
	380-3-60	342	418		26.9	139		26.9	139		3.9	68.3	90	80	173.7
	460-3-60	414	506		23.1	150		23.1	150		3.3	58.6	80	70	179.7
	575-3-60	518	632		19.9	109		19.9	109		2.6	50.0	60	60	134.1
	380/415-3-50	342	440		23.1	140		23.1	140		3.3	58.6	80	70	169.7
030	208/230-3-60	187	254	1	55.8	340	1	55.8	340	2	6.6	138.8	175	175	409.0
	380-3-60	342	418		34.0	196		34.0	196		3.9	84.3	110	100	237.8
	460-3-60	414	506		26.9	179		26.9	179		3.3	67.1	90	80	212.5
	575-3-60	518	632		23.7	132		23.7	132		2.6	58.5	80	70	160.9
	380/415-3-50	342	440		26.9	174		26.9	174		3.3	67.1	90	80	207.5
040	208/230-3-60	187	254	2	35.8	239	2	33.4	225	3	6.6	167.2	200	175	361.4
	380-3-60	342	418		23.7	145		19.2	140		3.9	103.5	125	110	218.9
	460-3-60	414	506		17.9	125		16.7	114		3.3	83.6	100	90	186.2
	575-3-60	518	632		14.3	80		13.4	80		2.6	66.7	80	70	128.8
	380/415-3-50	342	440		17.9	118		16.7	111		3.3	83.6	100	90	179.2
050	208/230-3-60	187	254	2	48.1	245	2	51.3	300	3	6.6	231.4	250	250	467.3
	380-3-60	342	418		23.7	145		26.9	139		3.9	119.6	125	125	225.0
	460-3-60	414	506		18.6	125		23.1	150		3.3	99.1	110	110	220.2
	575-3-60	518	632		14.7	100		19.9	109		2.6	82.0	100	90	166.1
	380/415-3-50	342	440		18.6	118		23.1	140		3.3	99.1	110	110	210.2
060	208/230-3-60	187	254	2	51.3	300	2	55.8	340	4	6.6	254.6	300	300	524.8
	380-3-60	342	418		26.9	139		34.0	196		3.9	145.9	175	175	299.4
	460-3-60	414	506		23.1	150		26.9	179		3.3	119.9	125	125	265.3
	575-3-60	518	632		19.9	109		23.7	132		2.6	103.5	125	110	205.9
	380/415-3-50	342	440		23.1	140		26.9	174		3.3	119.9	125	125	260.3
070	208/230-3-60	187	254	2	55.8	340	3	48.1	245	4	6.6	296.3	350	350	566.5
	380-3-60	342	418		34.0	196		23.7	145		3.9	163.2	175	175	316.7
	460-3-60	414	506		26.9	179		18.6	125		3.3	129.5	150	150	274.9
	575-3-60	518	632		23.7	132		14.7	100		2.6	107.8	125	125	210.2
	380/415-3-50	342	440		26.9	174		18.6	118		3.3	129.5	150	150	269.9
080	208/230-3-60	187	254	2	55.8	340	3	55.8	340	5	6.6	326.0	350	350	596.2
	380-3-60	342	418		34.0	196		34.0	196		3.9	198.0	225	225	351.5
	460-3-60	414	506		26.9	179		26.9	179		3.3	157.7	175	175	303.1
	575-3-60	518	632		23.7	132		23.7	132		2.6	137.4	150	150	239.8
	380/415-3-50	342	440		26.9	174		26.9	174		3.3	157.7	175	175	298.1
090	208/230-3-60	187	254	3	51.3	300	3	55.8	340	6	6.6	374.9	400	400	645.1
	380-3-60	342	418		26.9	139		34.0	196		3.9	214.6	225	225	368.1
	460-3-60	414	506		23.1	150		26.9	179		3.3	176.5	200	200	321.9
	575-3-60	518	632		19.9	109		23.7	132		2.6	152.3	175	150	254.7
	380/415-3-50	342	440		23.1	140		26.9	174		3.3	176.5	200	200	311.9
100	208/230-3-60	187	254	3	55.8	340	3	55.8	340	6	6.6	388.4	400	400	658.6
	380-3-60	342	418		34.0	196		34.0	196		3.9	235.9	250	250	389.4
	460-3-60	414	506		26.9	179		26.9	179		3.3	187.9	200	200	333.3
	575-3-60	518	632		23.7	132		23.7	132		2.6	163.7	175	175	266.1
	380/415-3-50	342	440		26.9	174		26.9	174		3.3	187.9	200	200	328.3
115	208/230-3-60	187	254	3	55.8	340	3	72.4	538	7	6.6	448.9	500	500	896.4
	380-3-60	342	418		34.0	196		35.3	290		3.9	244.0	250	250	489.9
	460-3-60	414	506		26.9	179		30.8	229		3.3	203.9	225	225	394.4
	575-3-60	518	632		23.7	132		25.0	180		2.6	170.6	175	175	319.3
	380/415-3-50	342	440		26.9	174		30.8	229		3.3	203.9	225	225	394.4
130	208/230-3-60	187	254	3	55.8	340	3	85.3	605	8	6.6	497.4	500	500	995.8
	380-3-60	342	418		34.0	196		51.9	380		3.9	301.9	350	300	617.0
	460-3-60	414	506		26.9	179		37.8	320		3.3	230.0	250	250	502.7
	575-3-60	518	632		23.7	132		34.6	250		2.6	204.4	225	225	411.1
	380/415-3-50	342	440		26.9	174		37.8	320		3.3	230.0	250	250	502.7

### LEGEND

- FLA — Full Load Amps
- ICF — Maximum Instantaneous Current Flow
- LRA — Locked Rotor Amps
- MCA — Minimum Circuit Amps
- MOCP — Maximum Overcurrent Protection
- RLA — Rated Load Amps

### NOTES:

1. Units are suitable for use on electrical systems where voltage supplied to the unit terminals is not below or above the listed minimum and maximum limits. Maximum allowable phase imbalance is: voltage 2%; amps 10%.
2. All units or modules have single point primary power connection. Main power must be supplied from a field-supplied disconnect.
3. For MCA that is less than or equal to 380 amps, 3 conductors are required. For MCA between 381 and 760 amps, 6 conductors are required. Calculation of conductors required is based on 75 C copper wire.

4. Wiring for main field supply must be rated 75 C. Use copper conductors only.
  - a. Incoming wire size range for terminal block with MCA up to 175 amps is 14 AWG (American Wire Gauge) to 2/0.
  - b. Incoming wire size range for terminal block with MCA from 175.1 amps to 420 amps is 2 AWG to 600 kcmil.
  - c. Incoming wire size range for non-fused disconnect with MCA up to 100 amps is 14 AWG to 1/0.
  - d. Incoming wire size range for non-fused disconnect with MCA from 100.1 amps to 200 amps is 6 AWG to 350 kcmil.
  - e. Incoming wire size range for non-fused disconnect with MCA from 200.1 amps to 450 amps is 3/0 to 500 kcmil.



### 38APD ELECTRICAL DATA — SINGLE POINT LOW SOUND FAN

38APD UNIT SIZE	V-Ph-Hz	SUPPLY VOLTAGE		COMPRESSOR						CONDENSER FAN		MCA	MOCP	REC FUSE	ICF
				CIRCUIT A			CIRCUIT B			Total Qty	FLA				
		Min	Max	Qty	RLA	LRA	Qty	RLA	LRA						
025	208/230-3-60	187	254	1	48.1	245	1	48.1	245	2	6.0	120.2	150	150	305.1
	380-3-60	342	418		23.7	145		23.7	145		3.9	61.1	80	70	176.5
	460-3-60	414	506		18.6	125		18.6	125		2.9	47.7	60	60	149.4
	575-3-60	518	632		14.7	100		14.7	100		2.4	37.9	50	45	119.5
	380/415-3-50	342	440		18.6	118		18.6	118		2.9	47.7	60	60	142.4
027	208/230-3-60	187	254	1	51.3	300	1	51.3	300	2	6.0	127.4	175	150	363.3
	380-3-60	342	418		26.9	139		26.9	139		3.9	68.3	90	80	173.7
	460-3-60	414	506		23.1	150		23.1	150		2.9	57.8	80	70	178.9
	575-3-60	518	632		19.9	109		19.9	109		2.4	49.6	60	60	133.7
	380/415-3-50	342	440		23.1	140		23.1	140		2.9	57.8	80	70	168.9
030	208/230-3-60	187	254	1	55.8	340	1	55.8	340	2	6.0	137.6	175	175	407.8
	380-3-60	342	418		34.0	196		34.0	196		3.9	84.3	110	100	237.8
	460-3-60	414	506		26.9	179		26.9	179		2.9	66.3	90	80	211.7
	575-3-60	518	632		23.7	132		23.7	132		2.4	58.1	80	70	160.5
	380/415-3-50	342	440		26.9	174		26.9	174		2.9	66.3	90	80	206.7
040	208/230-3-60	187	254	2	35.8	239	2	33.4	225	3	6.0	165.4	200	175	359.6
	380-3-60	342	418		23.7	145		19.2	140		3.9	103.5	125	110	218.9
	460-3-60	414	506		17.9	125		16.7	114		2.9	82.4	100	90	185.0
	575-3-60	518	632		14.3	80		13.4	80		2.4	66.1	80	70	128.2
	380/415-3-50	342	440		17.9	118		16.7	111		2.9	82.4	100	90	178.0
050	208/230-3-60	187	254	2	48.1	245	2	51.3	300	3	6.0	229.6	250	250	465.5
	380-3-60	342	418		23.7	145		26.9	139		3.9	119.6	125	125	225.0
	460-3-60	414	506		18.6	125		23.1	150		2.9	97.9	110	110	219.0
	575-3-60	518	632		14.7	100		19.9	109		2.4	81.4	100	90	165.5
	380/415-3-50	342	440		18.6	118		23.1	140		2.9	97.9	110	110	212.0
060	208/230-3-60	187	254	2	51.3	300	2	55.8	340	4	6.0	252.2	300	300	522.4
	380-3-60	342	418		26.9	139		34.0	196		3.9	145.9	175	175	299.4
	460-3-60	414	506		23.1	150		26.9	179		2.9	118.3	125	125	263.7
	575-3-60	518	632		19.9	109		23.7	132		2.4	102.7	125	110	205.1
	380/415-3-50	342	440		23.1	140		26.9	174		2.9	118.3	125	125	253.7
070	208/230-3-60	187	254	2	55.8	340	3	48.1	245	4	6.0	293.9	300	300	564.1
	380-3-60	342	418		34.0	196		23.7	145		3.9	163.2	175	175	316.7
	460-3-60	414	506		26.9	179		18.6	125		2.9	127.9	150	150	273.3
	575-3-60	518	632		23.7	132		14.7	100		2.4	107.0	125	125	209.4
	380/415-3-50	342	440		26.9	174		18.6	118		2.9	127.9	150	150	268.3
080	208/230-3-60	187	254	2	55.8	340	3	55.8	340	5	6.0	323.0	350	350	587.2
	380-3-60	342	418		34.0	196		34.0	196		3.9	198.0	225	225	347.6
	460-3-60	414	506		26.9	179		26.9	179		2.9	155.7	175	175	298.2
	575-3-60	518	632		23.7	132		23.7	132		2.4	136.4	150	150	236.4
	380/415-3-50	342	440		26.9	174		26.9	174		2.9	155.7	175	175	293.2
090	208/230-3-60	187	254	3	51.3	300	3	55.8	340	6	6.0	371.3	400	400	641.5
	380-3-60	342	418		26.9	139		34.0	196		3.9	214.6	225	225	368.1
	460-3-60	414	506		23.1	150		26.9	179		2.9	174.1	200	200	319.5
	575-3-60	518	632		19.9	109		23.7	132		2.4	151.1	175	150	253.5
	380/415-3-50	342	440		23.1	140		26.9	174		2.9	174.1	200	200	309.5
100	208/230-3-60	187	254	3	55.8	340	3	55.8	340	6	6.0	384.8	400	400	655.0
	380-3-60	342	418		34.0	196		34.0	196		3.9	235.9	250	250	389.4
	460-3-60	414	506		26.9	179		26.9	179		2.9	185.5	200	200	330.9
	575-3-60	518	632		23.7	132		23.7	132		2.4	162.5	175	175	264.9
	380/415-3-50	342	440		26.9	174		26.9	174		2.9	185.5	200	200	325.9
115	208/230-3-60	187	254	3	55.8	340	3	72.4	538	7	6.0	444.7	500	500	892.2
	380-3-60	342	418		34.0	196		35.3	290		3.9	244.0	275	250	489.9
	460-3-60	414	506		26.9	179		30.8	229		2.9	201.1	225	225	391.6
	575-3-60	518	632		23.7	132		25.0	180		2.4	169.2	175	175	317.9
	380/415-3-50	342	440		26.9	174		30.8	229		2.9	201.1	225	225	391.6
130	208/230-3-60	187	254	3	55.8	340	3	85.3	605	8	6.0	492.6	500	500	991.0
	380-3-60	342	418		34.0	196		51.9	380		3.9	301.9	300	300	617.0
	460-3-60	414	506		26.9	179		37.8	320		2.9	226.8	250	250	499.5
	575-3-60	518	632		23.7	132		34.6	250		2.4	202.8	225	225	409.5
	380/415-3-50	342	440		26.9	174		37.8	320		2.9	226.8	250	250	499.5

**LEGEND**

- FLA** — Full Load Amps
- ICF** — Maximum Instantaneous Current Flow
- LRA** — Locked Rotor Amps
- MCA** — Minimum Circuit Amps
- MOCP** — Maximum Overcurrent Protection
- RLA** — Rated Load Amps

**NOTES:**

1. Units are suitable for use on electrical systems where voltage supplied to the unit terminals is not below or above the listed minimum and maximum limits. Maximum allowable phase imbalance is: voltage 2%; amps 10%.
2. All units or modules have single point primary power connection. Main power must be supplied from a field-supplied disconnect.
3. For MCA that is less than or equal to 380 amps, 3 conductors are required. For MCA between 381 and 760 amps, 6 conductors are required. Calculation of conductors required is based on 75 C copper wire.

4. Wiring for main field supply must be rated 75 C. Use copper conductors only.
  - a. Incoming wire size range for terminal block with MCA up to 175 amps is 14 AWG (American Wire Gage) to 2/0.
  - b. Incoming wire size range for terminal block with MCA from 175.1 amps to 420 amps is 2 AWG to 600 kcmil.
  - c. Incoming wire size range for non-fused disconnect with MCA up to 100 amps is 14 AWG to 1/0.
  - d. Incoming wire size range for non-fused disconnect with MCA from 100.1 amps to 200 amps is 6 AWG to 350 kcmil.
  - e. Incoming wire size range for non-fused disconnect with MCA from 200.1 amps to 450 amps is 3/0 to 500 kcmil.





# Electrical data (cont)



## 38APD115,130 ELECTRICAL DATA — DUAL POINT STANDARD FAN

38APD UNIT SIZE	V-Ph-Hz	SUPPLY VOLTAGE		COMPRESSOR						CONDENSER FAN		MCA	MOCP	REC FUSE	ICF
				CIRCUIT A			CIRCUIT B			Total Qty	FLA				
		Min	Max	Qty	RLA	LRA	Qty	RLA	LRA						
115 Circuit 1	208/230-3-60	187	254	3	55.8	340	—	—	—	7	6.6	227.6	250	250	497.8
	380-3-60	342	418		34.0	196		—	—		3.9	137.8	150	150	291.3
	460-3-60	414	506		26.9	179		—	—		3.3	110.5	125	125	255.9
	575-3-60	518	632		23.7	132		—	—		2.6	95.2	110	110	197.6
	380/415-3-50	342	440		26.9	174		—	—		3.3	110.5	125	125	250.9
115 Circuit 2	208/230-3-60	187	254	—	—	—	3	72.4	538	—	—	235.3	300	300	682.8
	380-3-60	342	418		—	—		35.3	290		—	114.7	150	150	360.6
	460-3-60	414	506		—	—		30.8	229		—	100.1	125	110	290.6
	575-3-60	518	632		—	—		25.0	180		—	81.3	100	90	230.0
	380/415-3-50	342	440		—	—		30.8	229		—	100.1	125	110	290.6
130 Circuit 1	208/230-3-60	187	254	3	55.8	340	—	—	—	8	6.6	234.2	250	250	504.4
	380-3-60	342	418		34.0	196		—	—		3.9	141.7	175	175	295.2
	460-3-60	414	506		26.9	179		—	—		3.3	113.8	125	125	259.2
	575-3-60	518	632		23.7	132		—	—		2.6	97.8	110	110	200.2
	380/415-3-50	342	440		26.9	174		—	—		3.3	113.8	125	125	254.2
130 Circuit 2	208/230-3-60	187	254	—	—	—	3	85.3	605	—	—	277.2	350	300	775.6
	380-3-60	342	418		—	—		51.9	380		—	168.7	200	200	483.8
	460-3-60	414	506		—	—		37.8	320		—	122.9	150	150	395.6
	575-3-60	518	632		—	—		34.6	250		—	112.5	125	125	319.2
	380/415-3-50	342	440		—	—		37.8	320		—	122.9	150	150	395.6

## 38APD115,130 ELECTRICAL DATA — DUAL POINT LOW SOUND FAN

38APD UNIT SIZE	V-Ph-Hz	SUPPLY VOLTAGE		COMPRESSOR						CONDENSER FAN		MCA	MOCP	REC FUSE	ICF
				CIRCUIT A			CIRCUIT B			Total Qty	FLA				
		Min	Max	Qty	RLA	LRA	Qty	RLA	LRA						
115 Circuit 1	208/230-3-60	187	254	3	55.8	340	—	—	—	7	6.0	223.4	250	250	493.6
	380-3-60	342	418		34.0	196		—	—		3.9	137.8	150	150	291.3
	460-3-60	414	506		26.9	179		—	—		2.9	107.7	125	125	253.1
	575-3-60	518	632		23.7	132		—	—		2.4	93.8	110	100	196.2
	380/415-3-50	342	440		26.9	174		—	—		2.9	107.7	125	125	248.1
115 Circuit 2	208/230-3-60	187	254	—	—	—	3	72.4	538	—	—	235.3	300	300	682.8
	380-3-60	342	418		—	—		35.3	290		—	114.7	150	150	360.6
	460-3-60	414	506		—	—		30.8	229		—	100.1	125	110	290.6
	575-3-60	518	632		—	—		25.0	180		—	81.3	100	90	230.0
	380/415-3-50	342	440		—	—		30.8	229		—	100.1	125	110	290.6
130 Circuit 1	208/230-3-60	187	254	3	55.8	340	—	—	—	8	6.0	229.4	250	250	499.6
	380-3-60	342	418		34.0	196		—	—		3.9	141.7	175	175	295.2
	460-3-60	414	506		26.9	179		—	—		2.9	110.6	125	125	256.0
	575-3-60	518	632		23.7	132		—	—		2.4	96.2	110	110	198.6
	380/415-3-50	342	440		26.9	174		—	—		2.9	110.6	125	125	251.0
130 Circuit 2	208/230-3-60	187	254	—	—	—	3	85.3	605	—	—	277.2	350	300	775.6
	380-3-60	342	418		—	—		51.9	380		—	168.7	200	200	483.8
	460-3-60	414	506		—	—		37.8	320		—	122.9	150	150	395.6
	575-3-60	518	632		—	—		34.6	250		—	112.5	125	125	319.2
	380/415-3-50	342	440		—	—		37.8	320		—	122.9	150	150	395.6

### LEGEND

- FLA — Full Load Amps
- ICF — Maximum Instantaneous Current Flow
- LRA — Locked Rotor Amps
- MCA — Minimum Circuit Amps
- MOCP — Maximum Overcurrent Protection
- RLA — Rated Load Amps

### NOTES:

1. Units are suitable for use on electrical systems where voltage supplied to the unit terminals is not below or above the listed minimum and maximum limits. Maximum allowable phase imbalance is: voltage 2%; amps 10%.
2. All units or modules have single point primary power connection. Main power must be supplied from a field-supplied disconnect.
3. For MCA that is less than or equal to 380 amps, 3 conductors are required. For MCA between 381 and 760 amps, 6 conductors are required. Calculation of conductors required is based on 75 C copper wire.

4. Wiring for main field supply must be rated 75 C. Use copper conductors only.
  - a. Incoming wire size range for terminal block with MCA up to 175 amps is 14 AWG (American Wire Gauge) to 2/0.
  - b. Incoming wire size range for terminal block with MCA from 175.1 amps to 420 amps is 2 AWG to 600 kcmil.
  - c. Incoming wire size range for non-fused disconnect with MCA up to 100 amps is 14 AWG to 1/0.
  - d. Incoming wire size range for non-fused disconnect with MCA from 100.1 amps to 200 amps is 6 AWG to 350 kcmil.
  - e. Incoming wire size range for non-fused disconnect with MCA from 200.1 amps to 450 amps is 3/0 to 500 kcmil.





## Microprocessor

The *ComfortLink* microprocessor controls overall unit operation. Its central executive routine controls a number of processes simultaneously. These include internal timers, reading inputs, analog to digital conversions, fan control, display control, diagnostic control, output relay control, demand limit, capacity control, head pressure control, and temperature reset. Some processes are updated almost continuously, others every 2 to 3 seconds, and some every 30 seconds. The microprocessor also has the capability of communicating with the Carrier Comfort Network® (CCN) devices using the CCN protocol and when the accessory translator is used, other popular protocols including BACnet, Modbus\*, and LonWorks may also be used.

The microprocessor routine is started by switching the Emergency ON-OFF switch to ON position.

## Cooling control options

When mechanical cooling is required *ComfortLink* controls have the capability to control the staging of the compressors in several different ways. The control checks on various other operation parameters in the units to make sure that safety limits are not exceeded and the compressors are reliably operated.

The 38AP unit's *ComfortLink* controls offer two basic control approaches to mechanical cooling: constant volume (CV) with 2 stages of cooling, and variable air volume (VAV) with multiple stages of cooling. In addition to these traditional methods of control, the 38AP Series *ComfortLink* controls offer the ability to run multiple stages of cooling in constant volume applications and accept an external input for desired percentage of capacity.

CONTROL TYPE	COOLING CONTROL METHOD	UNIT SIZE	STAGING CONTROLLED BY
CV Thermostat 2-Stage	Thermostat	025 to 030	2-Stage Thermostat
CV Thermostat Multiple Stage	Thermostat	025 to 130	Supply Air Temperature
CV SPT Multiple Stage	Space Temperature, T-55/T-56	025 to 130	Supply Air Temperature
VAV	Supply Air Temperature	025 to 130	Supply Air Temperature
% Capacity	4-20 mA Input	025 to 130	Supply Air Temperature

### LEGEND

CV — Constant Volume  
 SPT — Space Temperature Sensor  
 VAV — Variable Air Volume

**Digital compressor** — The 38AP units offer a digital compressor factory-installed option composed of one digital compressor per unit to operate in combination with the remaining standard scroll compressor(s). The digital compressor has the ability to load and unload rapidly, and the load/unload timing can be varied to achieve unit capacity and closely match the load. The digital scroll option provides better capacity control by digitally modulating capacity, effectively increasing the number of compression stages. The digital scroll compressor modulates the capacity output using a digital unloader solenoid (DUS) which is activated by a signal from the *ComfortLink* controller to allow the scroll sets to rapidly separate (stop compressing) and reengage (resume compressing) during operation. Supply and return air sensors provide the input to the

*ComfortLink* controller necessary to stage unloading for all digital compressor units. The % capacity control function does not require input from supply and return air sensors. Refer to pages 82-90 for typical control wiring schematics of various common applications. The digital scroll operates in two stages, the loaded state when the solenoid valve is normally closed and the unloaded state when the solenoid valve is energized. These two states rapidly alternate between full capacity and zero capacity where during the loaded state the compressor operates like a standard scroll and delivers full capacity and mass flow, and during the unloaded state, the compressor does not flow refrigerant. The timing of the load/unload states is then tuned to match the desired output.

**Control type** — The control type determines the selection of the type of cooling control as well as the technique for selecting a cooling mode. The control types are:

**VAV** — This configuration refers to standard VAV operation. If the control is occupied and fan status input closed, the controls vary capacity based on supply-air temperature.

**CV TSTAT-2 Stage** — This configuration will force the control to monitor the thermostat inputs (Y1,Y2) to make a determination of mode and capacity.

**CV TSTAT-Multiple Stage** — This configuration will force the control to monitor the thermostat inputs (Y1,Y2) to make a determination of mode. Unlike traditional 2-stage thermostat control, the unit is allowed to use multiple stages of cooling control and perform VAV-style capacity control.

**CV SPT-Multiple Stage** — This configuration will force the control to monitor a space temperature sensor to make a determination of mode. The unit is allowed to use multiple stages of cooling control and perform VAV-style capacity control.

**% Capacity Control** — This configuration will force the control to monitor a 4 to 20 mA external input and vary compressor capacity from 0 to 100% depending on the 4 to 20 mA input.

## Cooling control method

Three different cooling control methods are used to step through the available stages of capacity depending on the unit size, circuiting, compressor type and cooling control method. Refer to Loading Sequences tables in the Application Data section on page 92 for specific capacity control.

**Multiple-Stage Supply Air Temperature (SAT)** — The capacity of the compressors are controlled based on the supply-air temperature and supply air temperature set point. This control method uses an adaptive PID (proportional, integral, derivative) algorithm to calculate the estimated change in supply-air temperature before engaging or disengaging the next stage of cooling. The algorithm compensates for varying conditions, including changing flow rates across the evaporator coil, to provide better overall control of compressor staging.

**Multiple Adaptive Demand** — This control method will base the capacity compressors on the supply air discharge temperature and one of two supply air temperature set points. The control will be able to call out a LOW COOL or

\*Registered trademark of Schneider Electric.

# Controls (cont)



a HIGH COOL mode and maintain a low or high cool supply air set point. The unit will use either the input from a conventional thermostat to turn the Y1, Y2 signals into a high and low demand signal, or with a space temperature sensor use a differential from set point to determine the mode. Once the mode has been established the control uses the same algorithm as with VAV control.

**Two-Stage Demand** — The unit will operate 2 stages of compressor capacity control.

**Demand limiting** — The control supports demand limiting using one or two fixed capacity limits initiated by discrete input switches or a variable capacity limit function based on an analog input signal. On CCN systems this can be done through the network, or for non-CCN network jobs this can be done by adding the energy management module.

## Diagnostics

The *ComfortLink* controls have fully integrated all controls and sensors into a common control system. The control monitors these inputs as well as many of the routines to provide advanced diagnostics. These include adaptive logic to allow the unit to continue to operate in a reduced output mode and automatic resets where applicable. The last 10 alarms and alerts are stored in memory and can be accessed through the display. The alarms can also be monitored through the Carrier Comfort Network® connection. The unit also supports the use of the hand held Navigator™ display which can be plugged in at the main control box.

Some of the diagnostics that are included are:

- Monitoring of all sensors
- Suction and discharge pressure transducers to provide compressor protection and coil freeze protection
- Monitoring of compressor status using compressor protection boards
- Low refrigerant charge protection
- Compressor reverse rotation protection
- Low superheat protection

## Control interface

The *ComfortLink* controller can interface with the Carrier Comfort Network devices through the 485 communications port. This will allow for the use of all system control programs. These include:

- Network Service Tool
- Touch Pilot™ device
- ComfortVIEW™ software
- CCN Web software

The control can also provide interface with non-Carrier energy management systems with the addition of either the BACnet/MODBUS Carrier translator or the Lon-Works Carrier translator. Several contact connection points have been provided in the main control box for interface to external controls and systems.

**Constant volume applications** — The units can be configured to operate in CV applications. The unit operates with either a standard (mechanical or electronic) 2-stage cool thermostat, or with an electronic room temperature sensor and a timeclock to establish unit start and stop times. With a standard thermostat (programmable is

optional), cooling operation is set by space temperature. With a space sensor and field-supplied timeclock, the machine will operate at default values unless they are changed using appropriate input devices.

Features with thermostat control of unit include:

- Two-stage cooling or adaptive multiple stage cooling which can provide 2 to 6 stages of capacity when supply air sensors installed. Refer to Loading Sequences tables in the Application Data section on page 92 for specific capacity control.
- Control of unit using Y1, Y2 thermostat or T55, T56, or T58 space sensors.
- Control of a condenser fan based on outdoor-air and condensing pressures.
- Compressor time guard override (power up and minimum on and off timers) to assure air return in low load conditions.

Features with sensor control (three options available) of unit include:

- T55 sensor will monitor room temperature and provide unoccupied override capability (1 to 4 hours).
- T56 sensor will monitor room temperature, provide unoccupied override capability (1 to 4 hours), and provide a temperature offset of 5° F (2.7° C) maximum.
- T58 CCN communicating sensor will provide the set point and space temperature values.

Standard features include:

- Two-stage cooling or adaptive multiple stage cooling which can provide 2 to 6 stages of capacity when supply air sensors installed. Refer to Loading Sequences tables in the Application Data section on page 92 for specific capacity control.
- Adjustment of space temperature set points of  $\pm 5^{\circ}$  F (2.7° C) when using a T56 sensor.
- 365-day timeclock with backup (supports minute, hour, and day of week, date, month, and year access). The timeclock includes the following features:
  - Daylight savings time function
  - Occupancy control with 8 periods for unit operation
  - Holiday table containing up to 18 holiday schedules
- Ability to initiate timed override from T55 or T56 sensors (for a timed period of 1 to 4 hours).
- For units connected into a CCN network the timeclock can be integrated into the overall building energy management system and be updated remotely.

**Variable air volume (VAV) applications** — Units that are configured to operate in VAV applications are designed to control the leaving-air temperature in cooling to a configurable set point. Some of the features for VAV units in a stand-alone application include:

- The units are shipped as operable, stand-alone units with the addition of a field-supplied timeclock to establish unit start and stop times or they can use *ComfortLink* time of day scheduling routine.
- Provide cooling control.
- Supports an optional space temperature sensor for mode control and supply air temperature reset.

- If space sensor is equipped with an override feature, the sensor will allow operation during the unoccupied period for a fixed length of time.
- Control board diagnostics.
- Control of an outdoor-air fan based upon outdoor-air temperature and saturated condensing temperature.
- Support of remote occupied/unoccupied input to start.
- Support a field test for field check out.
- Cooling capacity control of 2 to 6 stages plus economizer. Refer to Loading Sequences tables in the Application Data section on page 92 for specific capacity control.
- Compressor time delays to prevent rapid cycling of compressors.
- Automatic lead-lag control of compressors to reduce the number of compressor cycles. (When unit is equipped with digital scroll option, Sequence A is always used.)
- With the addition of the energy management board, the *ComfortLink* controls will also support demand limiting and remote set point control.

When the unit is connected to a CCN (Carrier Comfort Network<sup>®</sup>) system, the following additional features can be used:

- Interface of the unit clock with the CCN network clock and allow for remote configuration of the schedules.
- CCN demand limit participation.

### Sequence of operation

**Cooling, constant volume (CV) units** — On power up, the control module will activate the initialization software. The initialization software will determine the unit configuration and also initialize any controls loops and input/output devices. All alarms and configurations are saved in memory and maintained during power outages. All alarms will be maintained in memory and must be cleared through the display.

**Constant volume conventional thermostat control** — If the unit is equipped with a conventional thermostat with Y1, Y2 connections, then the control will perform the following sequence.

If Y1 is closed and the fan status input is closed then the control will stage the first compressor be sequenced on. If Y2 closes the control will stage the second compressor on. For units configured for TSTAT Multi, the control will add and remove compressor stages to maintain the low and high demand leaving air set points. If Y1 is closed at least one compressor stage will be turned on.

**Constant volume space temperature sensor control** — If the space temperature operation has been selected using a T55, T56, or T58 sensor then the following logic will be used to control the operation of the unit. If the internal timeclock is used, the control module determines the occupancy state based on the system time schedules. The set point for cooling is configurable through the display. If a T56 sensor is being used then the set point can be shifted by as much as 5 degrees. If the space temperature goes above the cooling set point then the unit will go into Cooling mode. The set point will depend on the space temperature. Once the fan status input is closed then the compressors will be sequenced on to maintain either the low or high load temperature set points.

**Variable air volume control** — On power up, the control module will activate the initialization software. The initialization software will determine the unit configuration and also initialize any controls loops and input/output devices. All alarms and configurations are saved in memory and maintained during power outages. All alarms will be maintained in memory and must be cleared through the display.

The unit will first determine the mode of operation. If the Cooling mode is required and the fan status input closed, then the controlling set point will be the leaving air temperature set point; then the leaving-air temperature will sequence to compressors on and off using a PID control loop.

# Typical control wiring schematics

## FIELD POWER WIRING

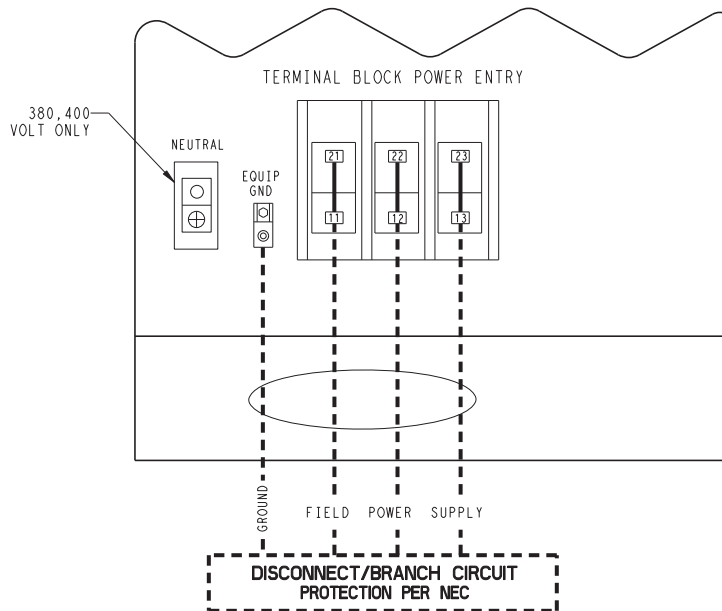

## TERMINAL BLOCK

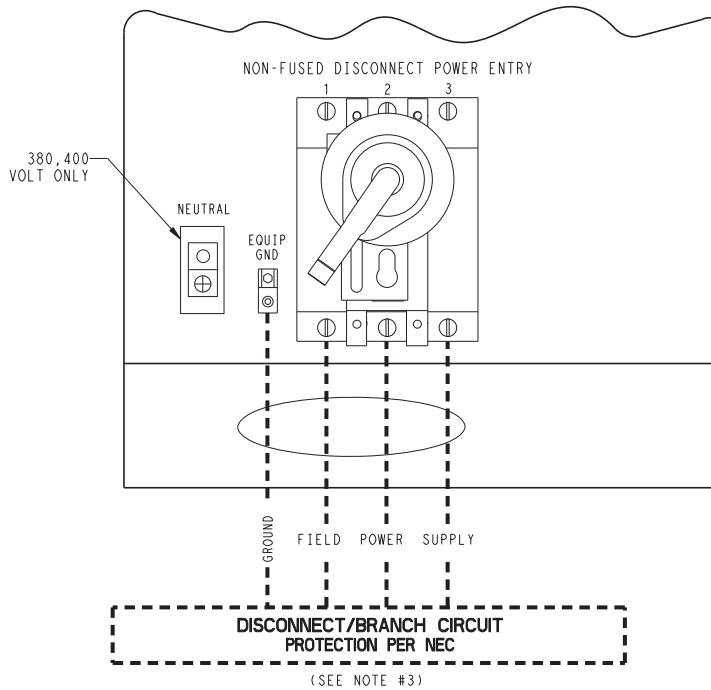

## NON-FUSED DISCONNECT

### LEGEND

- EQUIP GND** — Equipment Ground  
**NEC** — National Electrical Code

### NOTES:

1. Factory wiring is in accordance with UL 1995 standards. Field modifications or additions must be in compliance with all applicable codes.
2. All units or modules have single point primary power connection. Main power must be supplied from a field or factory-supplied disconnect.
3. Wiring for main field supply must be rated 75 C. Use copper conductors only.
  - a. Incoming wire size range for terminal block with MCA (minimum circuit amps) up to 175 amps is 14 AWG (American Wire Gage) to 2/0.
  - b. Incoming wire size range for terminal block with MCA from 175.1 amps to 420 amps is 2 AWG to 600 kcmil.

- c. Incoming wire size range for non-fused disconnect with MCA up to 100 amps is 14 AWG to 1/0.
  - d. Incoming wire size range for non-fused disconnect with MCA from 100.1 amps to 200 amps is 6 AWG to 350 kcmil.
  - e. Incoming wire size range for non-fused disconnect with MCA from 200.1 amps to 450 amps is 3/0 to 500 kcmil.
4. Refer to certified dimensional drawings for exact locations of the main power and control power entrance locations.

**VARIABLE AIR VOLUME APPLICATION WIRING DIAGRAM, C.TYP=1 (VAV),  
DIGITAL AND NON-DIGITAL, SIZES 025-130**

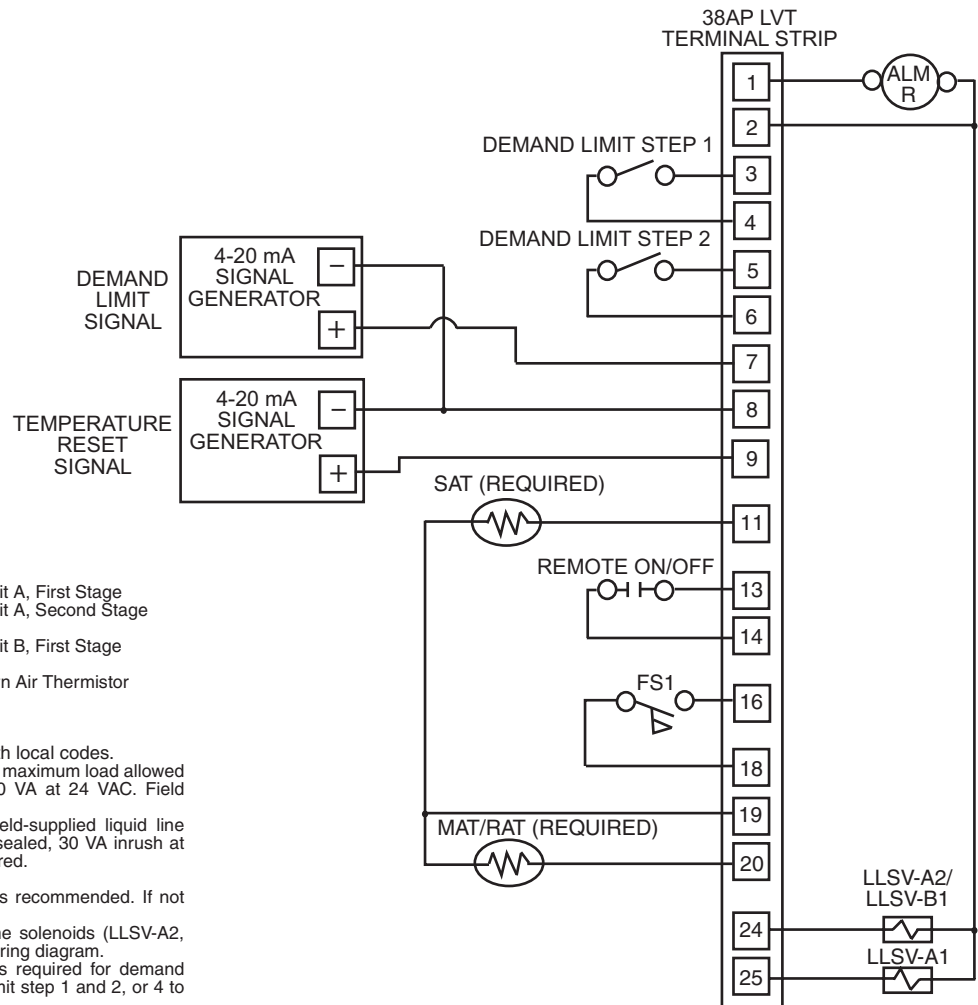

**LEGEND**

- ALM R** — Alarm Relay
- FS1** — Fan Status Switch, AHU1
- LLSV-A1** — Liquid Line Solenoid, Circuit A, First Stage
- LLSV-A2** — Liquid Line Solenoid, Circuit A, Second Stage (38APS040,050,065 only)
- LLSV-B1** — Liquid Line Solenoid, Circuit B, First Stage
- LVT** — Low Voltage Terminal
- MAT/RAT** — Mixed Air Thermistor/Return Air Thermistor
- SAT** — Supply Air Thermistor

**NOTES:**

1. Field wiring must be in accordance with local codes.
2. LVT-1 and 2 are for the alarm relay. The maximum load allowed for the alarm relay is 5 VA sealed, 10 VA at 24 VAC. Field power supply is not required.
3. LVT-24,25, and 2 are for control of field-supplied liquid line solenoid valve (LLSV) which is 15 VA sealed, 30 VA inrush at 24 VAC. Field power supply is not required.
4. All discrete inputs are 24 VAC.
5. Installation of fan status switch (FS1) is recommended. If not used, a jumper must be installed.
6. For 38APD units, if additional liquid line solenoids (LLSV-A2, LLSV-B2) are required, see separate wiring diagram.
7. Energy management module (EMM) is required for demand limit function, 4 to 20 mA or demand limit step 1 and 2, or 4 to 20 mA temperature reset.
8. The contacts for remote on-off, fan status switch and demand limit must be rated for dry circuit applications capable of handling a 24 VAC load up to 50 mA.



# Typical control wiring schematics (cont)



**CONSTANT VOLUME APPLICATION WIRING DIAGRAM THERMOSTAT MULTIPLE STAGES, C.TYP=3 (TSTAT MULTI), DIGITAL SIZES 025-130, NON-DIGITAL SIZES 040-130**

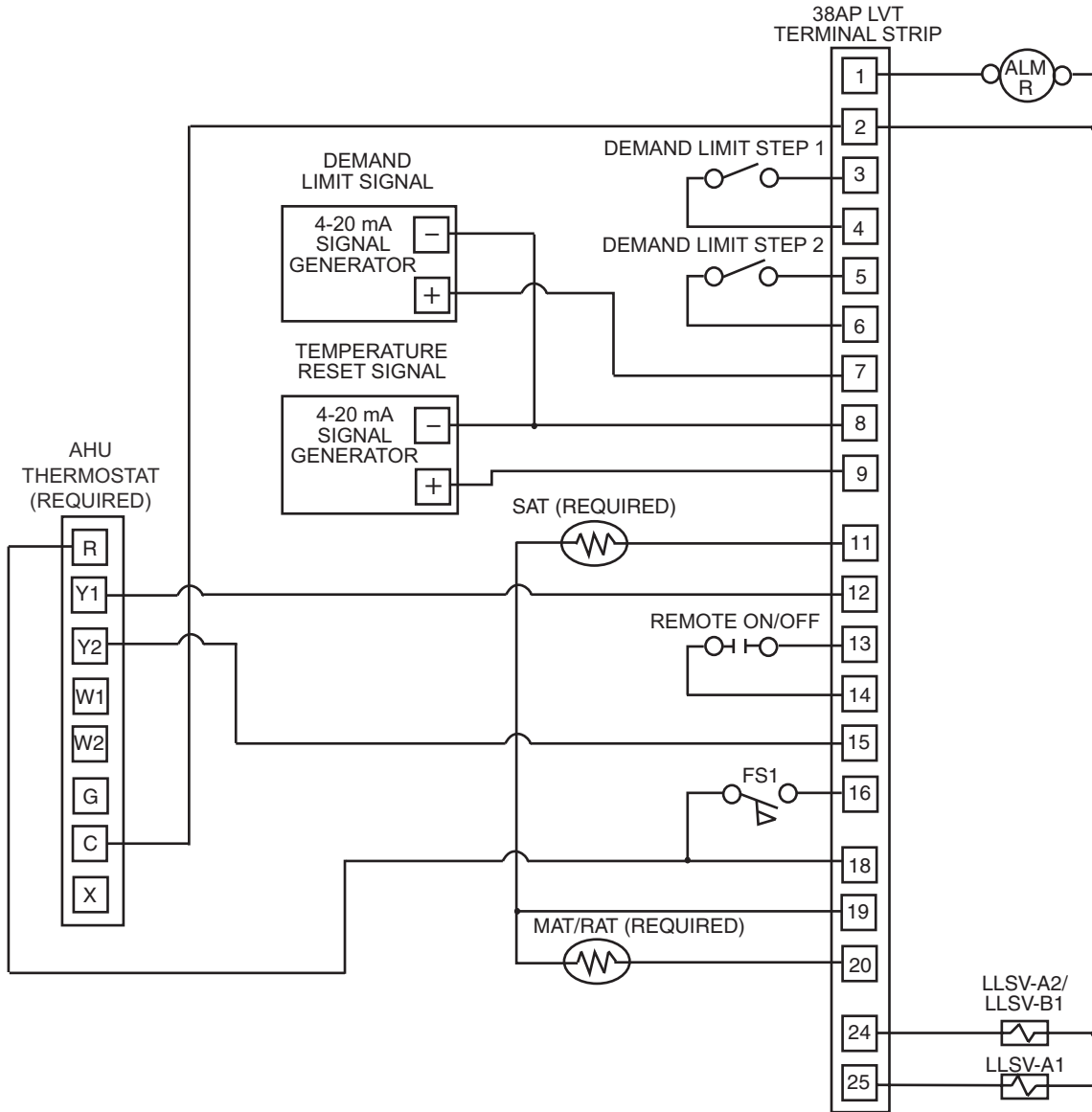

- LEGEND**
- ALM R — Alarm Relay
  - AHU — Air Handler Unit
  - FS1 — Fan Status Switch, AHU1
  - LLSV-A1 — Liquid Line Solenoid, Circuit A, First Stage
  - LLSV-A2 — Liquid Line Solenoid, Circuit A, Second Stage (38APS040,050,065 only)
  - LLSV-B1 — Liquid Line Solenoid, Circuit B, First Stage
  - LVT — Low Voltage Terminal
  - MAT/RAT — Mixed Air Thermistor/Return Air Thermistor
  - SAT — Supply Air Thermistor

**NOTES:**  
1. Field wiring must be in accordance with local codes.

2. LVT-1 and 2 are for the alarm relay. The maximum load allowed for the alarm relay is 5 VA sealed, 10 VA at 24 VAC. Field power supply is not required.
3. LVT-24,25, and 2 are for control of field-supplied liquid line solenoid valve (LLSV) which is 15 VA sealed, 30 VA inrush at 24 VAC. Field power supply is not required.
4. All discrete inputs are 24 VAC.
5. Installation of fan status switch (FS1) is recommended. If not used, a jumper must be installed.
6. For 38APD units, if additional liquid line solenoids (LLSV-A2, LLSV-B2) are required, see separate wiring diagram.
7. Energy management module (EMM) is required for demand limit functions, 4 to 20mA or demand limit step 1 and 2 or 4 to 20mA temperature reset.
8. The contacts for remote on-off, fan status switch and demand limit must be rated for dry circuit applications capable of handling a 24 VAC load up to 50 mA.



**CONSTANT VOLUME APPLICATION WIRING DIAGRAM 2-STAGE THERMOSTAT CONTROL,  
C.TYP=4 (TSTAT 2STG), NON-DIGITAL, SIZES 025-030**

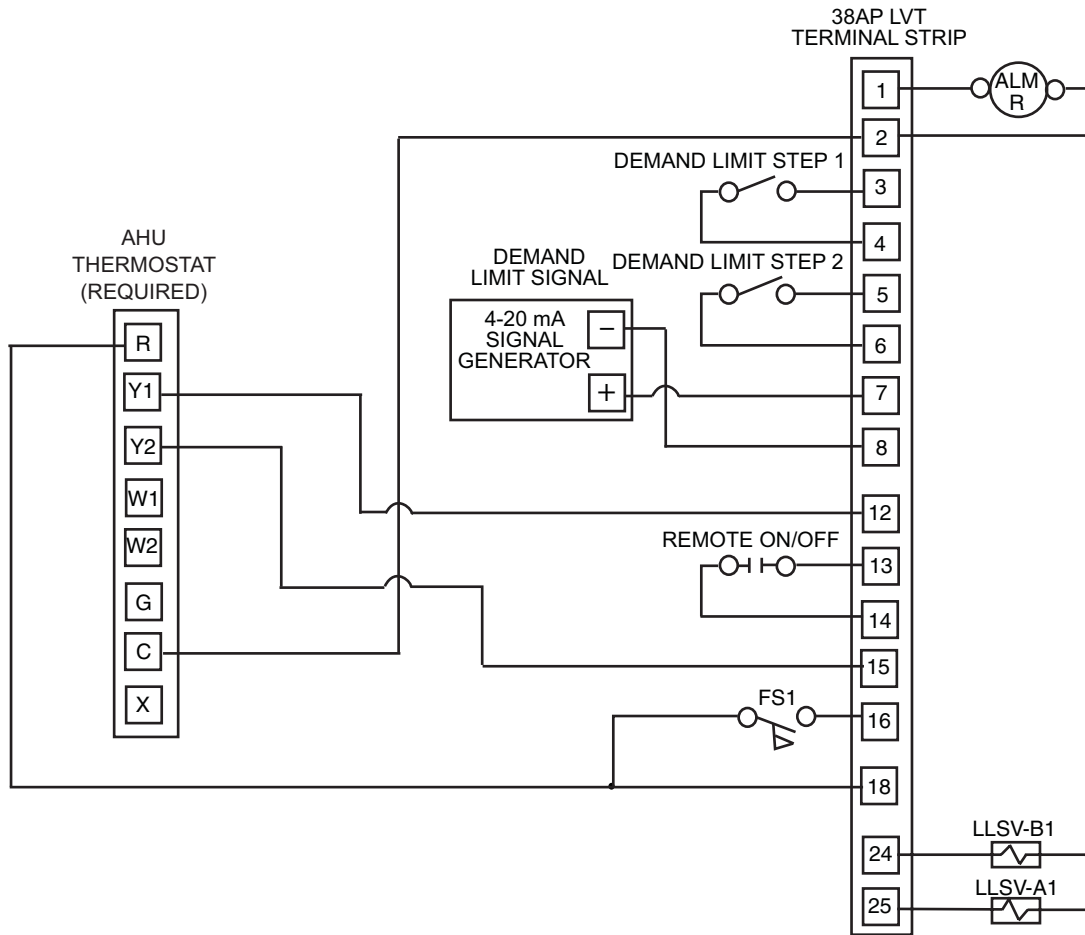

**LEGEND**

- AHU** — Air Handler Unit
- ALM R** — Alarm Relay
- FS1** — Fan Status Switch, AHU1
- LLSV-A1** — Liquid Line Solenoid, Circuit A, First Stage
- LLSV-B1** — Liquid Line Solenoid, Circuit B, First Stage
- LVT** — Low Voltage Terminal

**NOTES:**

1. Field wiring must be in accordance with local codes.
2. LVT-1 and 2 are for the alarm relay. The maximum load allowed for the alarm relay is 5 VA sealed, 10 VA at 24 VAC. Field power supply is not required.

3. LVT-24,25, and 2 are for control of field-supplied liquid line solenoid valve (LLSV) which is 15 VA sealed, 30 VA inrush at 24 VAC. Field power supply is not required.
4. All discrete inputs are 24 VAC.
5. Installation of fan status switch (FS1) is recommended. If not used, a jumper must be installed.
6. Energy management module (EMM) is required for demand limit functions, 4 to 20 mA or demand limit step 1 and 2.
7. This control scheme does not support digital compressor operation.
8. This control scheme is valid for 38APD,APS025, 027 and 030. It is not recommended for units with more than two compressors, 38APD040-130 and 38APS040-065.
9. The contacts for remote on-off, fan status switch and demand limit must be rated for dry circuit applications capable of handling a 24 VAC load up to 50 mA.

# Typical control wiring schematics (cont)



## CONSTANT VOLUME APPLICATION WIRING DIAGRAM SPACE TEMPERATURE SENSOR CONTROL, C.TYP=5 (SPT MULTI), DIGITAL AND NON-DIGITAL, SIZES 025-130

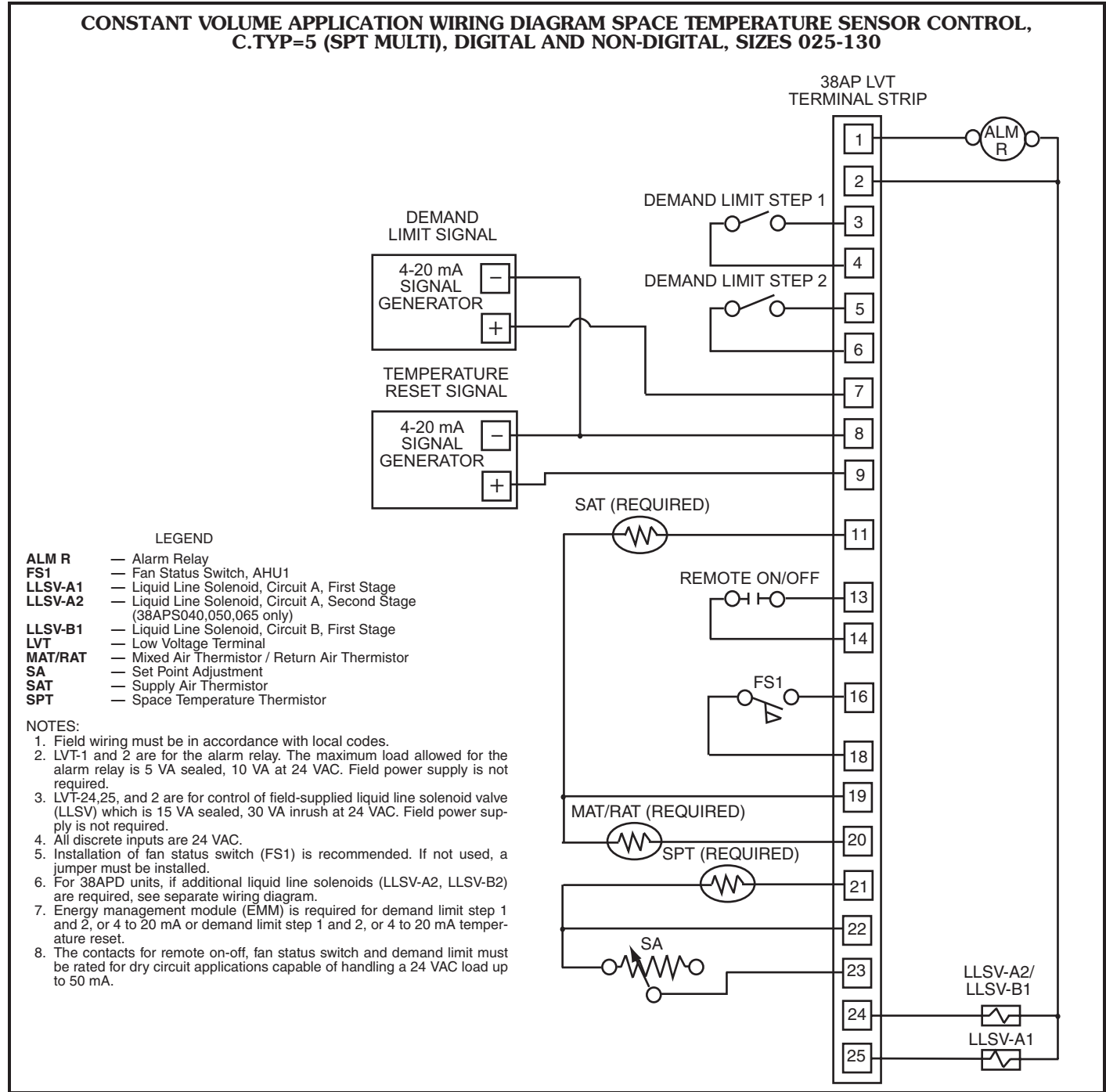

- LEGEND**
- ALM R — Alarm Relay
  - FS1 — Fan Status Switch, AHU1
  - LLSV-A1 — Liquid Line Solenoid, Circuit A, First Stage
  - LLSV-A2 — Liquid Line Solenoid, Circuit A, Second Stage (38APS040,050,065 only)
  - LLSV-B1 — Liquid Line Solenoid, Circuit B, First Stage
  - LVT — Low Voltage Terminal
  - MAT/RAT — Mixed Air Thermistor / Return Air Thermistor
  - SA — Set Point Adjustment
  - SAT — Supply Air Thermistor
  - SPT — Space Temperature Thermistor

- NOTES:**
1. Field wiring must be in accordance with local codes.
  2. LVT-1 and 2 are for the alarm relay. The maximum load allowed for the alarm relay is 5 VA sealed, 10 VA at 24 VAC. Field power supply is not required.
  3. LVT-24,25, and 2 are for control of field-supplied liquid line solenoid valve (LLSV) which is 15 VA sealed, 30 VA inrush at 24 VAC. Field power supply is not required.
  4. All discrete inputs are 24 VAC.
  5. Installation of fan status switch (FS1) is recommended. If not used, a jumper must be installed.
  6. For 38APD units, if additional liquid line solenoids (LLSV-A2, LLSV-B2) are required, see separate wiring diagram.
  7. Energy management module (EMM) is required for demand limit step 1 and 2, or 4 to 20 mA or demand limit step 1 and 2, or 4 to 20 mA temperature reset.
  8. The contacts for remote on-off, fan status switch and demand limit must be rated for dry circuit applications capable of handling a 24 VAC load up to 50 mA.

**PERCENT CAPACITY APPLICATION WIRING DIAGRAM,  
C.TYP=7 (PCT CAP), DIGITAL AND NON-DIGITAL, SIZES 025-130**

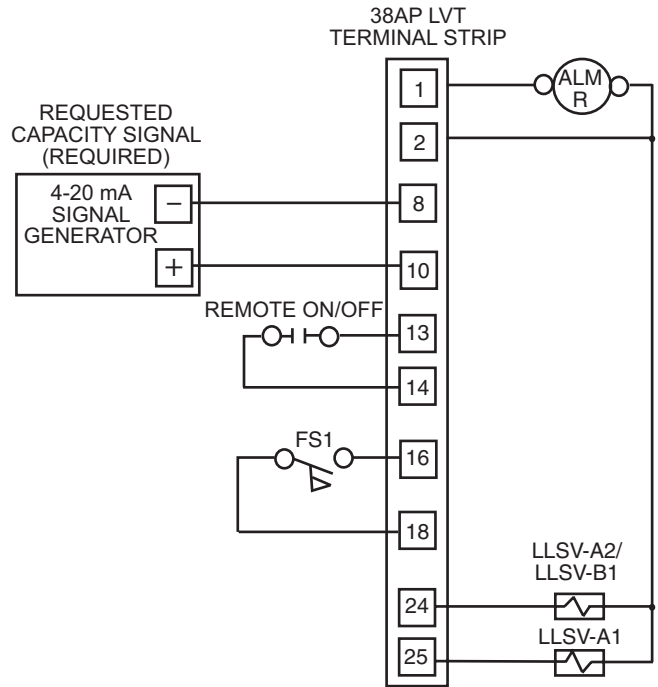

**LEGEND**

- ALM R** — Alarm Relay
- FS1** — Fan Status Switch, AHU1
- LLSV-A1** — Liquid Line Solenoid, Circuit A, First Stage
- LLSV-A2** — Liquid Line Solenoid, Circuit A, Second Stage  
(38APS040,050,065 only)
- LLSV-B1** — Liquid Line Solenoid, Circuit B, First Stage
- LVT** — Low Voltage Terminal

**NOTES:**

1. Field wiring must be in accordance with local codes.
2. LVT-1 and 2 are for the alarm relay. The maximum load allowed for the alarm relay is 5 VA sealed, 10 VA at 24 VAC. Field power supply is not required.
3. LVT-24,25, and 2 are for control of field-supplied liquid line solenoid valve (LLSV) which is 15 VA sealed, 30 VA inrush at 24 VAC. Field power supply is not required.
4. All discrete inputs are 24 VAC.
5. Installation of fan status switch (FS1) is recommended. If not used, a jumper must be installed.
6. For 38APD units, if additional liquid line solenoids (LLSV-A2, LLSV-B2) are required, see separate wiring diagram.
7. Energy management module (EMM) is required.
8. The contacts for remote on-off, fan status switch and demand limit must be rated for dry circuit applications capable of handling a 24 VAC load up to 50 mA.

# Typical control wiring schematics (cont)

## INDEPENDENT DUAL CIRCUIT CONTROL, C.TYP=8 (DUAL TSTAT), DUAL CIRCUIT NON-DIGITAL SIZES 040-130

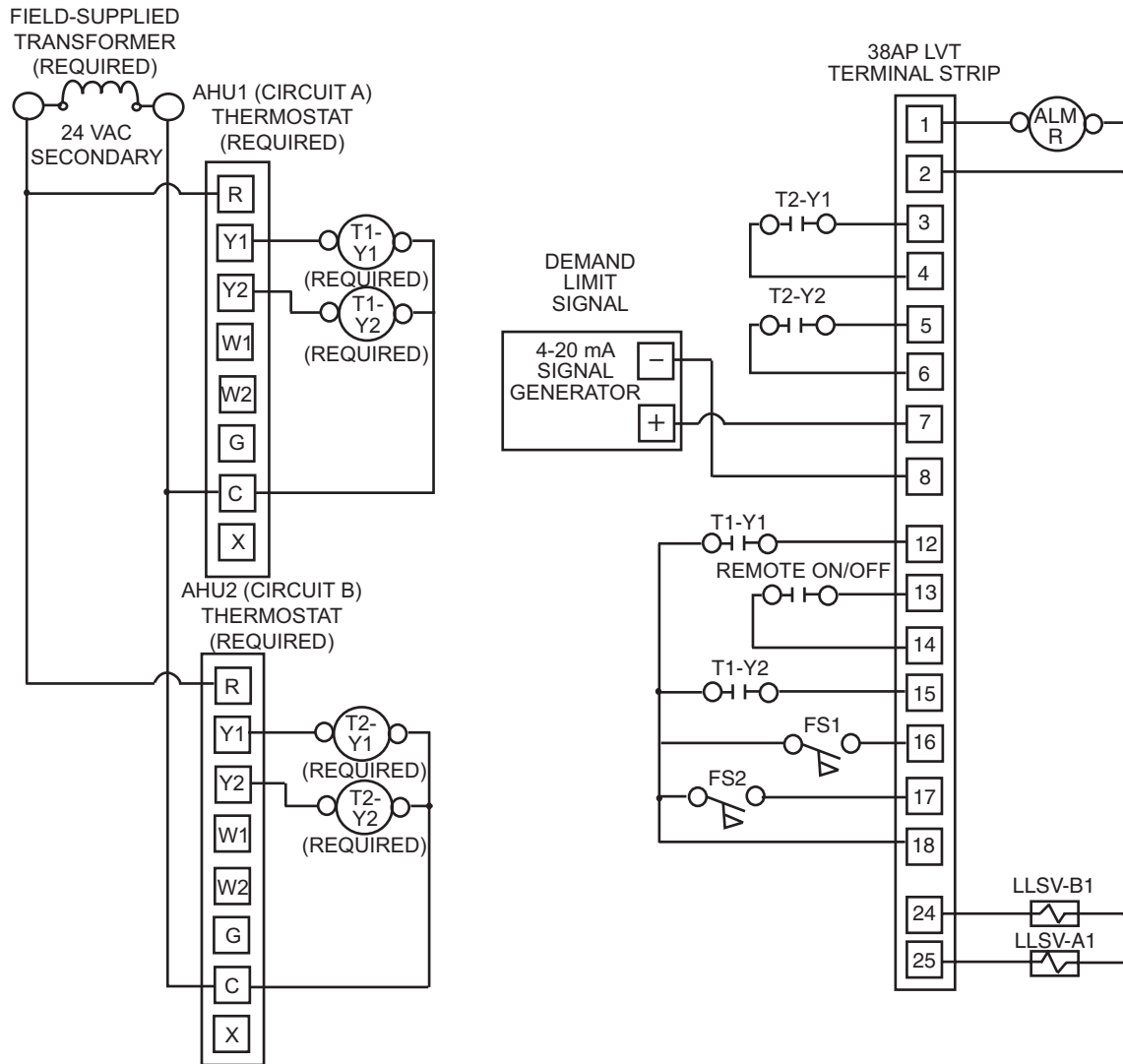

### LEGEND

- ALM R** — Alarm Relay
- AHU** — Air Handler Unit
- FS1** — Fan Status Switch, AHU1
- FS2** — Fan Status Switch, AHU2
- LLSV-A1** — Liquid Line Solenoid, Circuit A
- LLSV-B1** — Liquid Line Solenoid, Circuit B
- LVT** — Low Voltage Terminal
- T1** — AHU1 Thermostat
- T2** — AHU2 Thermostat

### NOTES:

1. AHU1 is connected to 38APD - Circuit A. AHU2 is connected to 38APD - Circuit B.
2. Field wiring must be in accordance with local codes.

3. LVT-1 and 2 are for the alarm relay. The maximum load allowed for the alarm relay is 5 VA sealed, 10 VA at 24 VAC. Field power supply is not required.
4. LVT-24,25, and 2 are for control of field-supplied liquid line solenoid valve (LLSV) which is 15 VA sealed, 30 VA inrush at 24 VAC. Field power supply is not required.
5. All discrete inputs are 24 VAC.
6. Installation of fan status switch (FS1, FS2) is recommended. If not used, a jumper must be installed.
7. If additional liquid line solenoids (LLSV-A2, LLSV-B2) are required, see separate wiring diagram.
8. Energy management module (EMM) is required.
9. This control scheme does not support digital compressor operation.
10. The contacts for remote on-off, fan status switch and demand limit must be rated for dry circuit applications capable of handling a 24 VAC load up to 50 mA.

**VARIABLE AIR VOLUME SETPOINT CONTROL APPLICATION WIRING DIAGRAM,  
C.TYP=9 (VAV SETPOINT), DIGITAL AND NON-DIGITAL, SIZES 025-130**

38AP LVT  
TERMINAL STRIP

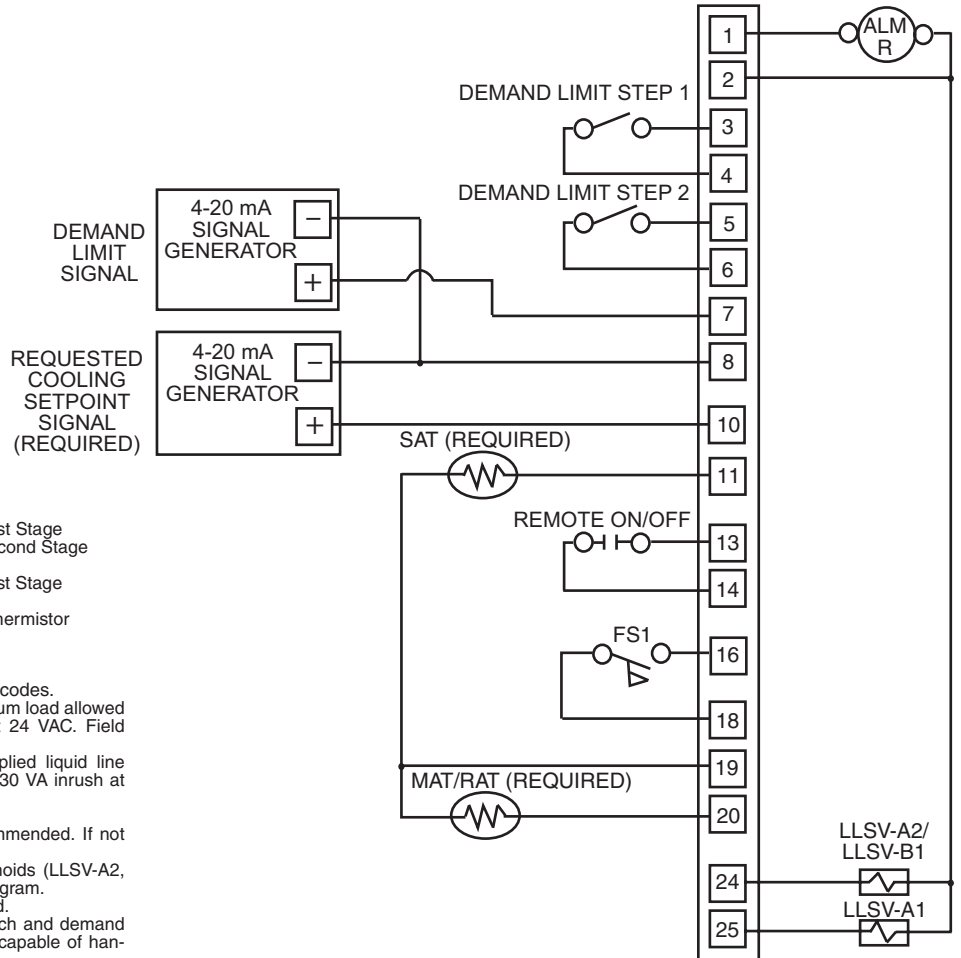

**LEGEND**

- ALM R** — Alarm Relay
- FS1** — Fan Status Switch, AHU1
- LLSV-A1** — Liquid Line Solenoid, Circuit A, First Stage
- LLSV-A2** — Liquid Line Solenoid, Circuit A, Second Stage (38APS040,050,065 only)
- LLSV-B1** — Liquid Line Solenoid, Circuit B, First Stage
- LVT** — Low Voltage Terminal
- MAT/RAT** — Mixed Air Thermistor/Return Air Thermistor
- SAT** — Supply Air Thermistor

**NOTES:**

1. Field wiring must be in accordance with local codes.
2. LVT-1 and 2 are for the alarm relay. The maximum load allowed for the alarm relay is 5 VA sealed, 10 VA at 24 VAC. Field power supply is not required.
3. LVT-24,25, and 2 are for control of field-supplied liquid line solenoid valve (LLSV) which is 15 VA sealed, 30 VA inrush at 24 VAC. Field power supply is not required.
4. All discrete inputs are 24 VAC.
5. Installation of fan status switch (FS1) is recommended. If not used, a jumper must be installed.
6. For 38APD units, if additional liquid line solenoids (LLSV-A2, LLSV-B2) are required, see separate wiring diagram.
7. Energy management module (EMM) is required.
8. The contacts for remote on-off, fan status switch and demand limit must be rated for dry circuit applications capable of handling a 24 VAC load up to 50 mA.

# Typical control wiring schematics (cont)

## MAT/RAT AND SAT SENSOR LAYOUT

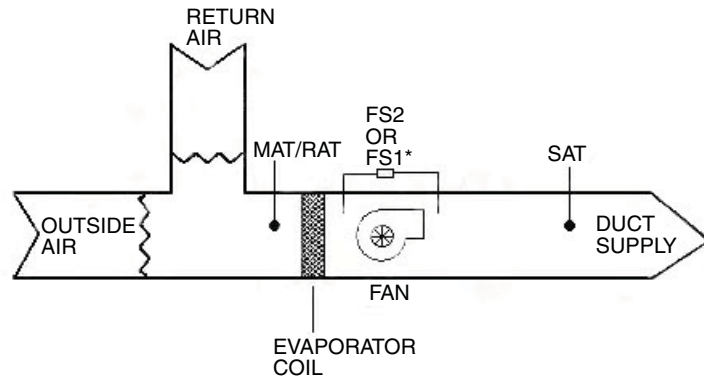

### LEGEND

- FS1** — Fan Status Switch (24-v)
- MAT** — Mixed Air Temperature Sensor
- RAT** — Return Air Temperature Sensor
- SAT** — Supply Air Temperature Sensor

\*FS1 can be pressure differential switch (shown), motor current detection, or sail switch.

## COMMUNICATIONS WIRING

### LVT CCN

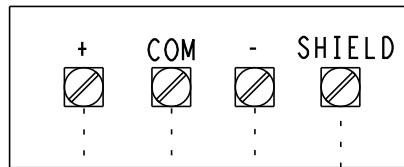

DATA COM PORT

# Application data



## Installation

The 38APD unit must be installed outdoors.

The 38AP condensing units are not designed for refrigeration duty. If applying with a third-party air-handling unit, a crossplot is required to determine the saturation temperature.

When considering location of the unit, be sure to consult National Electrical Code (NEC, U.S.A.) and local code requirements. Allow sufficient space for airflow, wiring, piping, and service. The placement area must be level and strong enough to support the operating weight of the unit. When unit is in proper location, use of mounting holes in base rails is recommended for securing unit to supporting structure. For mounting unit on vibration isolators, 4 x 24 in. (102 x 610 mm) perimeter support ASTM "C" channels between unit and the isolators are recommended with a minimum of 4 channels per unit. Fasteners for mounting unit are field supplied.

For 38AP025-060: When parallel condensing units are aligned such that coils face each other, a minimum of 6 ft (1829 mm) is recommended. When the parallel arrangement has only one coil drawing air from the space between condensing units, a minimum of 3.5 ft (1067 mm) is recommended. When parallel condensing units have no coils facing each other (a back-to-back arrangement), be sure to maintain the larger of the recommended service clearances associated with each chiller (see the certified drawings). Due to NEC (National Electric Code, U.S.A.) regulations, a minimum clearance of 4 ft (1219 mm) must be maintained on the side of the chiller that has an electrical box. Condensing unit fan discharge must be at least as high as adjacent solid walls.

For 38AP065-130: When condensing units are arranged in parallel, a minimum of 10 ft (3048 mm) between condensing units is recommended. Acceptable clearance on the side with a control box can be reduced to 4 ft (1.3 m) due to NEC (National Electric Code, U.S.A.) regulations, without sacrificing performance as long as the remaining three sides are unrestricted. For acceptable clearance with layout involving more than 2 condensing units, contact application engineering.

Refer to certified drawings for airflow clearances. Recommended minimum clearances are 6 ft (1829 mm) for unrestricted airflow and service on sides of unit, 4 ft (1219 mm) on ends, and unrestricted clear air space above the unit. Provide ample space to connect liquid and suction lines to indoor unit. For multiple units, allow 10 ft (3048 mm) separation between airflow surfaces. If walls surround the unit, wall height should not exceed the top of the unit fan discharge. Installation in a pit is not recommended.

The 38AP condensing units are not intended for remote cooler applications. For such purposes, please select a 30 Series chiller with remote cooler.

**IMPORTANT:** Be sure to mount unit level to ensure proper oil return to compressors.

**IMPORTANT:** Do NOT bury refrigerant piping underground. Failure to comply could result in equipment damage.

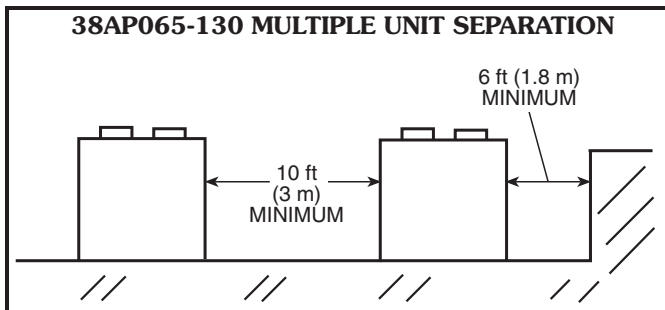
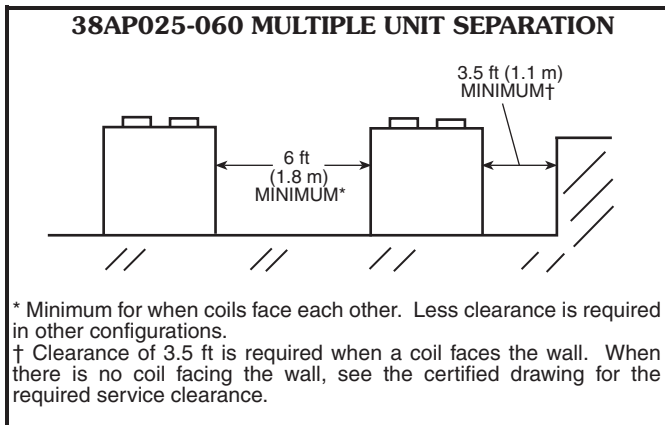

## Operating limits

Maximum outdoor ambient:

- 50/60 Hz, full capacity. . . . . 122 F (50 C)
- 50/60 Hz, unloaded. . . . . 125 F (51.6 C)
- 50/60 Hz, 100% outdoor air application  
 return air temperature maximum . . . . . 95 F (35 C)

Minimum operating outdoor air

- temperature with installed low ambient  
 head pressure control . . . . . -20 F (-28.8 C)

Minimum return air temperature . . . . . 55 F (-12.8 C)

Maximum return air temperature . . . . . 95 F (35 C)

Range of acceptable saturation

- suction temperature . . . . . 30 to 55 F (-1.1 to 12.8 C)

Maximum discharge temperature . . . . . 268 F (131 C)

Minimum suction superheat. . . . . 12° F (6.7° C)

Maximum vertical separation . . . 75 ft (22.8 m) 50/60 Hz

Check valves required for all units with linear line length more than 100 ft (30.5 m).

Check valves required for any 38AP025-030 dual circuit units where evaporator is located higher than the condensing unit and the linear line length is more than 55 ft (16.8 m).



# Application data (cont)



## NOTES:

1. Select indoor equipment at no less than 300 cfm per ton (40 L/s per kW) (nominal condensing unit capacity).
2. The total combined draw of the 2 field-supplied liquid line solenoid valves and one air handler fan contactor must not exceed 90 va. If the specified va must be exceeded, use a remote relay to control the load.
3. Select equipment to match or to be slightly less than peak load. This provides better humidity control, less unit cycling, and less part load operation.
4. Evaluate oil return when selecting vapor line sizes, especially for partial load conditions.
5. The indoor fan must operate when the outdoor unit is operating.
6. For VAV systems, the total building load is NOT the sum of the individual peak loads. Equipment selected for the sum of the individual peak loads will be oversized.
7. For VAV systems with supply-to-return air recycling, use the equipment room as a return-air plenum.
8. To minimize air recirculation, do not use concentric supply and return grilles.
9. All 38AP condensing units will come with one accumulator per circuit to protect compressors from liquid migration.
10. Ductwork should be sized according to unit size, not building load.
11. A field-supplied 5 to 15% bleed port TXV (thermostatic expansion valve) is required for every application.
12. The 38AP condensing units are not suitable for hot gas reheat applications.

## 38AP UNIT AMBIENT LIMITATIONS SINGLE CIRCUIT

38APS UNIT SIZE	MINIMUM LOW AMBIENT*† (Standard Unit)	MINIMUM LOW AMBIENT MOTORMASTER® CONTROL**	MAXIMUM AMBIENT††
025-065	45 F (7.2 C)	-20 F (-28.9 C)	122 F (50 C)

## DUAL CIRCUIT

38APD UNIT SIZE	MINIMUM LOW AMBIENT*† (Standard Unit)	MINIMUM LOW AMBIENT MOTORMASTER® CONTROL**	MAXIMUM AMBIENT††
025-040	32 F (0 C)	-20 F (-28.9 C)	122 F (50 C)
050-060	25 F (-3.9 C)	-20 F (-28.9 C)	122 F (50 C)
070-130	32 F (0 C)	-20 F (-28.9 C)	122 F (50 C)

\* Temperatures calculated with the minimum number of fans operating per circuit.  
† Minimum outdoor-air operating temperature is based on 90 F (32 C) saturated condensing temperature and 100% capacity.

\*\* Factory-installed option or field-installed accessory, including wind baffles.  
†† Operation above listed temperature depends on the saturated suction temperature at which the unit is operating. Refer to E-Cat for exact limitations.

## 38AP LOADING SEQUENCES LOADING SEQUENCES — SINGLE CIRCUIT

38APS UNIT SIZE	LOADING SEQUENCES			
	Standard Unit		Digital Option	
	Range (%)	Number of Steps	Range (%)	Number of Steps
025-030	50, 100	2	17-100	22
040-050	33, 66, 100	3	16-100	27
065	33, 66, 100	3	—	—

## LOADING SEQUENCES — DUAL CIRCUIT

38APD UNIT SIZE	LOADING SEQUENCES			
	Standard Unit		Digital Option	
	Range (%)	Number of Steps	Range (%)	Number of Steps
025-030	50, 100	2	17-100	22
040	27, 50, 73, 100	4	13-100	36
050-060	23, 50, 73, 100	4	11-100	36
070	24, 48, 65, 83, 100	5	11-100	45
080	20, 40, 60, 80, 100	5	9-100	45
090	15, 33, 49, 67, 82, 100	6	7-100	54
100	17, 33, 50, 67, 83, 100	6	8-100	54
115	14, 29, 44, 62, 81, 100	6	7-100	54
130	13, 25, 38, 59, 79, 100	6	6-100	54



# Application data (cont)



## REFRIGERANT PIPING REQUIREMENTS (cont) 38APS025-065 SINGLE-CIRCUIT UNITS (50 Hz)

50 Hz	38APS UNIT SIZE	CONN S,L (IN.)	TOTAL LINEAR LENGTH OF INTERCONNECTING PIPE, FT (M)															
			0-25 (0-7.6)		26-50 (7.9-15.2)		51-75 (15.5-22.9)		76-100 (23.1-30.5)		101-125 (30.8-38.1)		126-150 (38.4-45.7)		151-175 (46.0-53.3)		176-200 (53.6-61.0)	
			EQUIVALENT LENGTH, FT (M)*															
			0-37 (0-11.3)		38-75 (11.6-22.8)		76-112 (23.2-34.1)		113-150 (34.4-45.7)		151-187 (46.0-57.0)		188-225 (57.3-68.6)		226-262 (68.9-79.9)		263-300 (80.1-91.5)	
L	S	L	S	L	S	L	S	L	S	L	S	L	S	L	S			
025	15/8, 5/8	5/8	11/8	5/8	13/8	5/8	15/8	5/8	15/8	7/8	15/8	7/8	2 1/8	7/8	2 1/8	7/8	2 1/8	
027	15/8, 5/8	5/8	13/8	5/8	13/8	5/8	15/8	7/8	15/8	7/8	15/8	7/8	2 1/8	7/8	2 1/8	7/8	2 1/8	
030	15/8, 7/8	5/8	13/8	5/8	15/8	7/8	15/8	7/8	15/8	7/8	2 1/8	7/8	2 1/8	7/8	2 1/8	7/8	2 1/8	
040	2 1/8, 7/8	7/8	13/8	7/8	15/8	7/8	2 1/8	7/8	2 1/8	7/8	2 1/8	7/8	2 1/8	7/8	2 1/8	7/8	2 1/8	
050	2 1/8, 7/8	7/8	15/8	7/8	15/8	7/8	2 1/8	7/8	2 1/8	7/8	2 1/8	1 1/8	2 1/8	1 1/8	2 5/8	1 1/8	2 5/8	
065	2 5/8, 7/8	7/8	15/8	7/8	2 1/8	7/8	2 1/8	1 1/8	2 1/8	1 1/8	2 1/8	1 1/8	2 5/8	1 1/8	2 5/8	1 1/8	2 5/8	

## 38APD025-130 DUAL-CIRCUIT UNITS (50 Hz)

50 Hz	38APD UNIT SIZE	CONN S,L (IN.)	TOTAL LINEAR LENGTH OF INTERCONNECTING PIPE, FT (M)															
			0-25 (0-7.6)		26-50 (7.9-15.2)		51-75 (15.5-22.9)		76-100 (23.1-30.5)		101-125 (30.8-38.1)		126-150 (38.4-45.7)		151-175 (46.0-53.3)		176-200 (53.6-61.0)	
			EQUIVALENT LENGTH, FT (M)*															
			0-37 (0-11.3)		38-75 (11.6-22.8)		76-112 (23.2-34.1)		113-150 (34.4-45.7)		151-187 (46.0-57.0)		188-225 (57.3-68.6)		226-262 (68.9-79.9)		263-300 (80.1-91.5)	
L	S	L	S	L	S	L	S	L	S	L	S	L	S	L	S			
025	Ckt A	13/8, 5/8	5/8	11/8	5/8	11/8	5/8	11/8	5/8	13/8	5/8	13/8	5/8	13/8	5/8	13/8	5/8	13/8
	Ckt B	13/8, 5/8	5/8	11/8	5/8	11/8	5/8	11/8	5/8	13/8	5/8	13/8	5/8	13/8	5/8	13/8	5/8	13/8
027	Ckt A	13/8, 5/8	5/8	11/8	5/8	11/8	5/8	11/8	5/8	13/8	5/8	13/8	5/8	13/8	5/8	13/8	5/8	13/8
	Ckt B	13/8, 5/8	5/8	11/8	5/8	11/8	5/8	11/8	5/8	13/8	5/8	13/8	5/8	13/8	5/8	13/8	5/8	13/8
030	Ckt A	13/8, 5/8	5/8	11/8	5/8	11/8	5/8	13/8	5/8	13/8	5/8	13/8	5/8	13/8	5/8	15/8	5/8	15/8
	Ckt B	13/8, 5/8	5/8	11/8	5/8	11/8	5/8	13/8	5/8	13/8	5/8	13/8	5/8	13/8	5/8	15/8	5/8	15/8
040	Ckt A	15/8, 5/8	5/8	11/8	5/8	13/8	5/8	13/8	5/8	15/8	5/8	15/8	5/8	15/8	7/8	15/8	7/8	2 1/8
	Ckt B	15/8, 5/8	5/8	11/8	5/8	13/8	5/8	13/8	5/8	13/8	5/8	15/8	5/8	15/8	7/8	15/8	7/8	15/8
050	Ckt A	15/8, 5/8	5/8	11/8	5/8	13/8	5/8	15/8	5/8	15/8	7/8	15/8	7/8	2 1/8	7/8	2 1/8	7/8	2 1/8
	Ckt B	15/8, 5/8	5/8	13/8	5/8	13/8	5/8	15/8	7/8	15/8	7/8	15/8	7/8	2 1/8	7/8	2 1/8	7/8	2 1/8
060	Ckt A	15/8, 5/8	5/8	13/8	5/8	13/8	5/8	15/8	7/8	15/8	7/8	15/8	7/8	2 1/8	7/8	2 1/8	7/8	2 1/8
	Ckt B	15/8, 5/8	5/8	13/8	5/8	15/8	7/8	15/8	7/8	15/8	7/8	2 1/8	7/8	2 1/8	7/8	2 1/8	7/8	2 1/8
070	Ckt A	15/8, 7/8	5/8	13/8	5/8	15/8	7/8	15/8	7/8	15/8	7/8	2 1/8	7/8	2 1/8	7/8	2 1/8	7/8	2 1/8
	Ckt B	2 1/8, 7/8	5/8	13/8	7/8	15/8	7/8	2 1/8	7/8	2 1/8	7/8	2 1/8	7/8	2 1/8	7/8	2 1/8	7/8	2 1/8
080	Ckt A	15/8, 7/8	5/8	13/8	5/8	15/8	7/8	15/8	7/8	15/8	7/8	2 1/8	7/8	2 1/8	7/8	2 1/8	7/8	2 1/8
	Ckt B	2 1/8, 7/8	7/8	15/8	7/8	15/8	7/8	2 1/8	7/8	2 1/8	7/8	2 1/8	1 1/8	2 1/8	1 1/8	2 5/8	1 1/8	2 5/8
090	Ckt A	2 1/8, 7/8	7/8	13/8	7/8	15/8	7/8	2 1/8	7/8	2 1/8	7/8	2 1/8	7/8	2 1/8	7/8	2 1/8	7/8	2 1/8
	Ckt B	2 1/8, 7/8	7/8	15/8	7/8	15/8	7/8	2 1/8	7/8	2 1/8	7/8	2 1/8	1 1/8	2 1/8	1 1/8	2 5/8	1 1/8	2 5/8
100	Ckt A	2 1/8, 7/8	7/8	15/8	7/8	15/8	7/8	2 1/8	7/8	2 1/8	7/8	2 1/8	1 1/8	2 1/8	1 1/8	2 5/8	1 1/8	2 5/8
	Ckt B	2 1/8, 7/8	7/8	15/8	7/8	15/8	7/8	2 1/8	7/8	2 1/8	7/8	2 1/8	1 1/8	2 1/8	1 1/8	2 5/8	1 1/8	2 5/8
115	Ckt A	2 1/8, 7/8	7/8	15/8	7/8	15/8	7/8	2 1/8	7/8	2 1/8	7/8	2 1/8	1 1/8	2 1/8	1 1/8	2 5/8	1 1/8	2 5/8
	Ckt B	2 5/8, 7/8	7/8	15/8	7/8	2 1/8	7/8	2 1/8	1 1/8	2 1/8	1 1/8	2 1/8	1 1/8	2 5/8	1 1/8	2 5/8	1 1/8	2 5/8
130	Ckt A	2 1/8, 7/8	7/8	15/8	7/8	15/8	7/8	2 1/8	7/8	2 1/8	7/8	2 1/8	1 1/8	2 1/8	1 1/8	2 5/8	1 1/8	2 5/8
	Ckt B	2 5/8, 1 1/8	1 1/8	2 1/8	1 1/8	2 1/8	1 1/8	2 5/8	1 1/8	2 5/8	1 1/8	2 5/8	1 1/8	2 5/8	1 1/8	3 1/8	1 3/8	3 1/8

### LEGEND

L — Liquid Line  
S — Suction Line

\*Equivalent Length shown is based on the Total Linear Length plus an additional 50% for fittings and valves. If application requires more than 50% additional losses for fittings and valves, calculate the equivalent length and find pipe size using the Equivalent Length columns.

### NOTES:

- Shading indicates double suction riser required on units if condensing unit is located higher than evaporator.
- Maximum vertical separation between evaporator and condensing unit is 75 ft (22.8 m).

- Suction and liquid line sizing is based on pressure drop equivalent to 2 F (1.1 C) at nominal rating conditions.
- All pipe sizes are OD inches. Equivalent sizes in millimeters follow:

in.	mm
1/2	12.7
5/8	15.9
7/8	22.2
1 1/8	28.6
1 3/8	34.9
1 5/8	41.3
2 1/8	54.0
2 5/8	66.7
3 1/8	79.4



**REFRIGERANT PIPING REQUIREMENTS (cont)**  
**38APS025-065 SINGLE-CIRCUIT UNITS DOUBLE SUCTION RISER (60 Hz)**

60 Hz	38APS UNIT SIZE	CONN S.L (IN.)	TOTAL LINEAR LENGTH OF INTERCONNECTING PIPE, ft (m)																																
			0-25 (0-7.6)			26-50 (7.9-15.2)			51-75 (15.5-22.9)			76-100 (23.1-30.5)			101-125 (30.8-38.1)			126-150 (38.4-45.7)			151-175 (46.0-53.3)			176-200 (53.6-61.0)											
			EQUIVALENT LENGTH, ft (m)*									0-37 (0-11.3)			38-75 (11.6-22.8)			76-112 (22.2-34.1)			113-150 (34.4-45.7)			151-187 (46.0-57.0)			188-225 (57.3-68.6)			226-262 (68.9-79.9)			263-300 (80.1-91.5)		
			A	B	C	A	B	C	A	B	C	A	B	C	A	B	C	A	B	C	A	B	C	A	B	C	A	B	C						
025	1 5/8, 5/8	—	—	—	—	—	—	—	—	—	—	—	—	—	1 3/8	1 5/8	2 1/8	1 3/8	1 5/8	2 1/8	1 3/8	1 5/8	2 1/8	1 3/8	1 5/8	2 1/8	1 3/8	1 5/8	2 1/8						
027	1 5/8, 5/8	—	—	—	—	—	—	—	—	—	—	—	1 3/8	1 5/8	2 1/8	1 3/8	1 5/8	2 1/8	1 3/8	1 5/8	2 1/8	1 3/8	1 5/8	2 1/8	1 3/8	1 5/8	2 1/8	1 3/8	1 5/8	2 1/8					
030	1 5/8, 7/8	—	—	—	—	—	—	—	1 3/8	1 5/8	2 1/8	1 3/8	1 5/8	2 1/8	1 3/8	1 5/8	2 1/8	1 3/8	1 5/8	2 1/8	1 3/8	1 5/8	2 1/8	1 3/8	1 5/8	2 1/8	1 3/8	1 5/8	2 1/8						
040	2 1/8, 7/8	—	—	—	1 3/8	1 5/8	2 1/8	1 3/8	1 5/8	2 1/8	1 3/8	1 5/8	2 1/8	1 3/8	1 5/8	2 1/8	1 3/8	1 5/8	2 1/8	1 3/8	1 5/8	2 1/8	1 3/8	1 5/8	2 1/8	1 3/8	1 5/8	2 1/8	1 3/8	1 5/8	2 1/8				
050	2 1/8, 7/8	—	—	—	1 3/8	1 5/8	2 1/8	1 3/8	1 5/8	2 1/8	1 3/8	1 5/8	2 1/8	1 3/8	1 5/8	2 1/8	1 3/8	1 5/8	2 1/8	1 3/8	1 5/8	2 1/8	1 3/8	1 5/8	2 1/8	1 3/8	1 5/8	2 1/8	1 3/8	1 5/8	2 1/8				
065	2 5/8, 7/8	—	—	—	—	—	—	—	—	—	—	—	—	—	1 5/8	2 1/8	2 5/8	1 5/8	2 1/8	2 5/8	1 5/8	2 1/8	2 5/8	1 5/8	2 1/8	2 5/8	1 5/8	2 1/8	2 5/8	1 5/8	2 1/8	2 5/8			

**38APD025-130 DUAL-CIRCUIT UNITS DOUBLE SUCTION RISER (60 Hz)**

60 Hz	38APD UNIT SIZE	CONN S.L (IN.)	TOTAL LINEAR LENGTH OF INTERCONNECTING PIPE, ft (m)																																
			0-25 (0-7.6)			26-50 (7.9-15.2)			51-75 (15.5-22.9)			76-100 (23.1-30.5)			101-125 (30.8-38.1)			126-150 (38.4-45.7)			151-175 (46.0-53.3)			176-200 (53.6-61.0)											
			EQUIVALENT LENGTH, ft (m)*									0-37 (0-11.3)			38-75 (11.6-22.8)			76-112 (22.2-34.1)			113-150 (34.4-45.7)			151-187 (46.0-57.0)			188-225 (57.3-68.6)			226-262 (68.9-79.9)			263-300 (80.1-91.5)		
			A	B	C	A	B	C	A	B	C	A	B	C	A	B	C	A	B	C	A	B	C	A	B	C	A	B	C	A	B	C			
025	Ckt A	1 3/8, 5/8	—	—	—	—	—	—	—	—	—	—	—	—	—	—	—	—	—	—	—	—	—	—	—	—	—	—	—	—					
	Ckt B	1 3/8, 5/8	—	—	—	—	—	—	—	—	—	—	—	—	—	—	—	—	—	—	—	—	—	—	—	—	—	—	—	—					
027	Ckt A	1 3/8, 5/8	—	—	—	—	—	—	—	—	—	—	—	—	—	—	—	—	—	—	—	—	—	—	—	—	—	—	—	—					
	Ckt B	1 3/8, 5/8	—	—	—	—	—	—	—	—	—	—	—	—	—	—	—	—	—	—	—	—	—	—	—	—	—	—	—	—					
030	Ckt A	1 3/8, 5/8	—	—	—	—	—	—	—	—	—	—	—	—	—	—	—	—	—	—	—	—	—	—	—	—	—	—	—	—					
	Ckt B	1 3/8, 5/8	—	—	—	—	—	—	—	—	—	—	—	—	—	—	—	—	—	—	—	—	—	—	—	—	—	—	—	—					
040	Ckt A	1 5/8, 5/8	—	—	—	—	—	—	—	—	—	—	—	—	—	—	—	—	1 3/8	1 5/8	2 1/8	1 3/8	1 5/8	2 1/8	1 3/8	1 5/8	2 1/8	1 3/8	1 5/8	2 1/8					
	Ckt B	1 5/8, 5/8	—	—	—	—	—	—	—	—	—	—	—	—	—	—	—	—	—	—	—	—	—	—	—	—	—	—	—	—					
050	Ckt A	1 5/8, 5/8	—	—	—	—	—	—	—	—	—	—	—	1 3/8	1 5/8	2 1/8	1 3/8	1 5/8	2 1/8	1 3/8	1 5/8	2 1/8	1 3/8	1 5/8	2 1/8	1 3/8	1 5/8	2 1/8	1 3/8	1 5/8	2 1/8				
	Ckt B	1 5/8, 5/8	—	—	—	—	—	—	—	—	—	—	1 3/8	1 5/8	2 1/8	1 3/8	1 5/8	2 1/8	1 3/8	1 5/8	2 1/8	1 3/8	1 5/8	2 1/8	1 3/8	1 5/8	2 1/8	1 3/8	1 5/8	2 1/8					
060	Ckt A	1 5/8, 5/8	—	—	—	—	—	—	—	—	—	—	1 3/8	1 5/8	2 1/8	1 3/8	1 5/8	2 1/8	1 3/8	1 5/8	2 1/8	1 3/8	1 5/8	2 1/8	1 3/8	1 5/8	2 1/8	1 3/8	1 5/8	2 1/8					
	Ckt B	1 5/8, 5/8	—	—	—	—	—	—	1 3/8	1 5/8	2 1/8	1 3/8	1 5/8	2 1/8	1 3/8	1 5/8	2 1/8	1 3/8	1 5/8	2 1/8	1 3/8	1 5/8	2 1/8	1 3/8	1 5/8	2 1/8	1 3/8	1 5/8	2 1/8						
070	Ckt A	1 5/8, 7/8	—	—	—	—	—	—	—	—	—	—	1 3/8	1 5/8	2 1/8	1 3/8	1 5/8	2 1/8	1 3/8	1 5/8	2 1/8	1 3/8	1 5/8	2 1/8	1 3/8	1 5/8	2 1/8	1 3/8	1 5/8	2 1/8					
	Ckt B	2 1/8, 7/8	—	—	—	—	—	—	—	—	—	—	1 3/8	1 5/8	2 1/8	1 3/8	1 5/8	2 1/8	1 3/8	1 5/8	2 1/8	1 3/8	1 5/8	2 1/8	1 3/8	1 5/8	2 1/8	1 3/8	1 5/8	2 1/8					
080	Ckt A	1 5/8, 7/8	—	—	—	—	—	—	—	—	—	—	1 3/8	1 5/8	2 1/8	1 3/8	1 5/8	2 1/8	1 3/8	1 5/8	2 1/8	1 3/8	1 5/8	2 1/8	1 3/8	1 5/8	2 1/8	1 3/8	1 5/8	2 1/8					
	Ckt B	2 1/8, 7/8	—	—	—	1 3/8	1 5/8	2 1/8	1 3/8	1 5/8	2 1/8	1 3/8	1 5/8	2 1/8	1 3/8	1 5/8	2 1/8	1 3/8	1 5/8	2 1/8	1 3/8	1 5/8	2 1/8	1 3/8	1 5/8	2 1/8	1 3/8	1 5/8	2 1/8						
090	Ckt A	2 1/8, 7/8	—	—	—	—	—	—	—	—	—	—	1 3/8	1 5/8	2 1/8	1 3/8	1 5/8	2 1/8	1 3/8	1 5/8	2 1/8	1 3/8	1 5/8	2 1/8	1 3/8	1 5/8	2 1/8	1 3/8	1 5/8	2 1/8					
	Ckt B	2 1/8, 7/8	—	—	—	1 3/8	1 5/8	2 1/8	1 3/8	1 5/8	2 1/8	1 3/8	1 5/8	2 1/8	1 3/8	1 5/8	2 1/8	1 3/8	1 5/8	2 1/8	1 3/8	1 5/8	2 1/8	1 3/8	1 5/8	2 1/8	1 3/8	1 5/8	2 1/8						
100	Ckt A	2 1/8, 7/8	—	—	—	—	—	—	—	—	—	—	1 3/8	1 5/8	2 1/8	1 3/8	1 5/8	2 1/8	1 3/8	1 5/8	2 1/8	1 3/8	1 5/8	2 1/8	1 3/8	1 5/8	2 1/8	1 3/8	1 5/8	2 1/8					
	Ckt B	2 1/8, 7/8	—	—	—	1 3/8	1 5/8	2 1/8	1 3/8	1 5/8	2 1/8	1 3/8	1 5/8	2 1/8	1 3/8	1 5/8	2 1/8	1 3/8	1 5/8	2 1/8	1 3/8	1 5/8	2 1/8	1 3/8	1 5/8	2 1/8	1 3/8	1 5/8	2 1/8						
115	Ckt A	2 1/8, 7/8	—	—	—	—	—	—	—	—	—	—	1 3/8	1 5/8	2 1/8	1 3/8	1 5/8	2 1/8	1 3/8	1 5/8	2 1/8	1 3/8	1 5/8	2 1/8	1 3/8	1 5/8	2 1/8	1 3/8	1 5/8	2 1/8					
	Ckt B	2 5/8, 7/8	—	—	—	—	—	—	—	—	—	—	—	—	—	—	—	—	1 5/8	2 1/8	2 5/8	1 5/8	2 1/8	2 5/8	1 5/8	2 1/8	2 5/8	1 5/8	2 1/8	2 5/8					
130	Ckt A	2 1/8, 7/8	—	—	—	—	—	—	—	—	—	—	1 3/8	1 5/8	2 1/8	1 3/8	1 5/8	2 1/8	1 3/8	1 5/8	2 1/8	1 3/8	1 5/8	2 1/8	1 3/8	1 5/8	2 1/8	1 3/8	1 5/8	2 1/8					
	Ckt B	2 5/8, 1 1/8	—	—	—	—	—	—	—	—	—	—	1 5/8	2 1/8	2 5/8	1 5/8	2 1/8	2 5/8	1 5/8	2 1/8	2 5/8	1 5/8	2 1/8	2 5/8	1 5/8	2 1/8	2 5/8	1 5/8	2 1/8	2 5/8					

**LEGEND**

- Not Required
- Pipe A** — Suction Riser without Trap
- Pipe B** — Suction Riser with Trap
- Pipe C** — Suction Line Condensing Unit

\*Equivalent Length shown is based on the Total Linear Length plus an additional 50% for fittings and valves. If application requires more than 50% additional losses for fittings and valves, calculate the equivalent length and find pipe size using the Equivalent Length columns.

**NOTES:**

1. Refer to the Suction Line Piping figure on page 97 for suction line piping locations.
2. Suction and liquid line sizing is based on pressure drop equivalent to 2 F (1.1 C) at nominal rating conditions.
3. Maximum vertical separation between evaporator and condensing unit is 75 ft (22.8 m).

4. All pipe sizes are OD inches. Equivalent sizes in millimeters follow:

in.	mm
1/2	12.7
5/8	15.9
7/8	22.2
1 1/8	28.6
1 3/8	34.9
1 5/8	41.3
2 1/8	54.0
2 5/8	66.7
3 1/8	79.4

# Application data (cont)



## REFRIGERANT PIPING REQUIREMENTS (cont) 38APS025-065 SINGLE-CIRCUIT UNITS DOUBLE SUCTION RISER (50 Hz)

50 Hz	38APS UNIT SIZE	CONN S.L (IN.)	TOTAL LINEAR LENGTH OF INTERCONNECTING PIPE, ft (m)																																
			0-25 (0-7.6)			26-50 (7.9-15.2)			51-75 (15.5-22.9)			76-100 (23.1-30.5)			101-125 (30.8-38.1)			126-150 (38.4-45.7)			151-175 (46.0-53.3)			176-200 (53.6-61.0)											
			EQUIVALENT LENGTH, ft (m)*									0-37 (0-11.3)			38-75 (11.6-22.8)			76-112 (22.2-34.1)			113-150 (34.4-45.7)			151-187 (46.0-57.0)			188-225 (57.3-68.6)			226-262 (68.9-79.9)			263-300 (80.1-91.5)		
			A	B	C	A	B	C	A	B	C	A	B	C	A	B	C	A	B	C	A	B	C	A	B	C									
	025	1 5/8, 5/8	—	—	—	—	—	—	—	—	—	—	—	—	—	—	—	—	1 3/8	1 5/8	2 1/8	1 3/8	1 5/8	2 1/8	1 3/8	1 5/8	2 1/8	1 3/8	1 5/8	2 1/8					
	027	1 5/8, 5/8	—	—	—	—	—	—	—	—	—	—	—	—	—	—	—	—	1 3/8	1 5/8	2 1/8	1 3/8	1 5/8	2 1/8	1 3/8	1 5/8	2 1/8	1 3/8	1 5/8	2 1/8					
	030	1 5/8, 7/8	—	—	—	—	—	—	—	—	—	—	—	—	—	—	—	—	1 3/8	1 5/8	2 1/8	1 3/8	1 5/8	2 1/8	1 3/8	1 5/8	2 1/8	1 3/8	1 5/8	2 1/8					
	040	2 1/8, 7/8	—	—	—	—	—	—	1 3/8	1 5/8	2 1/8	1 3/8	1 5/8	2 1/8	1 3/8	1 5/8	2 1/8	1 3/8	1 5/8	2 1/8	1 3/8	1 5/8	2 1/8	1 3/8	1 5/8	2 1/8	1 3/8	1 5/8	2 1/8						
	050	2 1/8, 7/8	—	—	—	—	—	—	1 3/8	1 5/8	2 1/8	1 3/8	1 5/8	2 1/8	1 3/8	1 5/8	2 1/8	1 3/8	1 5/8	2 1/8	1 3/8	1 5/8	2 1/8	1 3/8	1 5/8	2 1/8	1 3/8	1 5/8	2 1/8						
	065	2 5/8, 7/8	—	—	—	1 3/8	1 5/8	2 1/8	1 3/8	1 5/8	2 1/8	1 3/8	1 5/8	2 1/8	1 3/8	1 5/8	2 1/8	1 3/8	1 5/8	2 1/8	1 3/8	1 5/8	2 1/8	1 3/8	1 5/8	2 1/8	1 3/8	1 5/8	2 1/8						

## 38APD025-130 DUAL-CIRCUIT UNITS DOUBLE SUCTION RISER (50 Hz)

50 Hz	38APD UNIT SIZE	CONN S.L (IN.)	TOTAL LINEAR LENGTH OF INTERCONNECTING PIPE, ft (m)																																
			0-25 (0-7.6)			26-50 (7.9-15.2)			51-75 (15.5-22.9)			76-100 (23.1-30.5)			101-125 (30.8-38.1)			126-150 (38.4-45.7)			151-175 (46.0-53.3)			176-200 (53.6-61.0)											
			EQUIVALENT LENGTH, ft (m)*									0-37 (0-11.3)			38-75 (11.6-22.8)			76-112 (22.2-34.1)			113-150 (34.4-45.7)			151-187 (46.0-57.0)			188-225 (57.3-68.6)			226-262 (68.9-79.9)			263-300 (80.1-91.5)		
			A	B	C	A	B	C	A	B	C	A	B	C	A	B	C	A	B	C	A	B	C	A	B	C	A	B	C						
	025	Ckt A	1 3/8, 5/8	—	—	—	—	—	—	—	—	—	—	—	—	—	—	—	—	—	—	—	—	—	—	—	—	—	—						
Ckt B		1 3/8, 5/8	—	—	—	—	—	—	—	—	—	—	—	—	—	—	—	—	—	—	—	—	—	—	—	—	—	—	—						
	027	Ckt A	1 3/8, 5/8	—	—	—	—	—	—	—	—	—	—	—	—	—	—	—	—	—	—	—	—	—	—	—	—	—	—						
Ckt B		1 3/8, 5/8	—	—	—	—	—	—	—	—	—	—	—	—	—	—	—	—	—	—	—	—	—	—	—	—	—	—	—						
	030	Ckt A	1 3/8, 5/8	—	—	—	—	—	—	—	—	—	—	—	—	—	—	—	—	—	—	—	—	—	—	—	—	—	—						
Ckt B		1 3/8, 5/8	—	—	—	—	—	—	—	—	—	—	—	—	—	—	—	—	—	—	—	—	—	—	—	—	—	—	—						
	040	Ckt A	1 5/8, 5/8	—	—	—	—	—	—	—	—	—	—	—	—	—	—	—	—	—	—	—	—	—	—	—	1 3/8	1 5/8	2 1/8						
Ckt B		1 5/8, 5/8	—	—	—	—	—	—	—	—	—	—	—	—	7/8	1 3/8	1 5/8	7/8	1 3/8	1 5/8	7/8	1 3/8	1 5/8	7/8	1 3/8	1 5/8	7/8	1 3/8	1 5/8						
	050	Ckt A	1 5/8, 5/8	—	—	—	—	—	—	—	—	—	—	—	—	—	—	—	—	—	—	—	—	—	—	—	—	—	—						
Ckt B		1 5/8, 5/8	—	—	—	—	—	—	—	—	—	—	—	—	—	—	—	—	—	—	—	—	—	—	—	—	—	—	—						
	060	Ckt A	1 5/8, 5/8	—	—	—	—	—	—	—	—	—	—	—	—	—	—	—	—	—	—	—	—	—	—	—	—	—	—						
Ckt B		1 5/8, 5/8	—	—	—	—	—	—	—	—	—	—	—	—	1 3/8	1 5/8	2 1/8	1 3/8	1 5/8	2 1/8	1 3/8	1 5/8	2 1/8	1 3/8	1 5/8	2 1/8	1 3/8	1 5/8	2 1/8						
	070	Ckt A	1 5/8, 7/8	—	—	—	—	—	—	—	—	—	—	—	—	—	—	—	—	—	—	—	—	—	—	—	—	—	—						
Ckt B		2 1/8, 7/8	—	—	—	—	—	—	—	1 3/8	1 5/8	2 1/8	1 3/8	1 5/8	2 1/8	1 3/8	1 5/8	2 1/8	1 3/8	1 5/8	2 1/8	1 3/8	1 5/8	2 1/8	1 3/8	1 5/8	2 1/8	1 3/8	1 5/8	2 1/8					
	080	Ckt A	1 5/8, 7/8	—	—	—	—	—	—	—	—	—	—	—	—	—	—	—	—	—	—	—	—	—	—	—	—	—	—						
Ckt B		2 1/8, 7/8	—	—	—	—	—	—	—	1 3/8	1 5/8	2 1/8	1 3/8	1 5/8	2 1/8	1 3/8	1 5/8	2 1/8	1 3/8	1 5/8	2 1/8	1 3/8	1 5/8	2 1/8	1 3/8	1 5/8	2 1/8	1 3/8	1 5/8	2 1/8					
	090	Ckt A	2 1/8, 7/8	—	—	—	—	—	—	—	—	—	—	—	—	—	—	—	—	—	—	—	—	—	—	—	—	—	—						
Ckt B		2 1/8, 7/8	—	—	—	—	—	—	—	1 3/8	1 5/8	2 1/8	1 3/8	1 5/8	2 1/8	1 3/8	1 5/8	2 1/8	1 3/8	1 5/8	2 1/8	1 3/8	1 5/8	2 1/8	1 3/8	1 5/8	2 1/8	1 3/8	1 5/8	2 1/8					
	100	Ckt A	2 1/8, 7/8	—	—	—	—	—	—	—	—	—	—	—	—	—	—	—	—	—	—	—	—	—	—	—	—	—	—						
Ckt B		2 1/8, 7/8	—	—	—	—	—	—	—	1 3/8	1 5/8	2 1/8	1 3/8	1 5/8	2 1/8	1 3/8	1 5/8	2 1/8	1 3/8	1 5/8	2 1/8	1 3/8	1 5/8	2 1/8	1 3/8	1 5/8	2 1/8	1 3/8	1 5/8	2 1/8					
	115	Ckt A	2 1/8, 7/8	—	—	—	—	—	—	—	—	—	—	—	—	—	—	—	—	—	—	—	—	—	—	—	—	—	—						
Ckt B		2 5/8, 7/8	—	—	—	1 3/8	1 5/8	2 1/8	1 3/8	1 5/8	2 1/8	1 3/8	1 5/8	2 1/8	1 3/8	1 5/8	2 1/8	1 3/8	1 5/8	2 1/8	1 3/8	1 5/8	2 1/8	1 3/8	1 5/8	2 1/8	1 3/8	1 5/8	2 1/8						
	130	Ckt A	2 1/8, 7/8	—	—	—	—	—	—	—	—	—	—	—	—	—	—	—	—	—	—	—	—	—	—	—	—	—	—						
Ckt B		2 5/8, 1 1/8	—	—	—	—	—	—	—	1 5/8	2 1/8	2 5/8	1 5/8	2 1/8	2 5/8	1 5/8	2 1/8	2 5/8	1 5/8	2 1/8	2 5/8	1 5/8	2 1/8	2 5/8	1 5/8	2 1/8	2 5/8	1 5/8	2 1/8						

### LEGEND

- Not Required
- Pipe A — Suction Riser without Trap
- Pipe B — Suction Riser with Trap
- Pipe C — Suction Line Condensing Unit

\*Equivalent Length shown is based on the Total Linear Length plus an additional 50% for fittings and valves. If application requires more than 50% additional losses for fittings and valves, calculate the equivalent length and find pipe size using the Equivalent Length columns.

### NOTES:

1. Refer to the Suction Line Piping figure on page 97 for suction line piping locations.
2. Suction and liquid line sizing is based on pressure drop equivalent to 2 F (1.1 C) at nominal rating conditions.
3. Maximum vertical separation between evaporator and condensing unit is 75 ft (22.8 m).

4. All pipe sizes are OD inches. Equivalent sizes in millimeters follow:

in.	mm
1/2	12.7
5/8	15.9
7/8	22.2
1 1/8	28.6
1 3/8	34.9
1 5/8	41.3
2 1/8	54.0
2 5/8	66.7
3 1/8	79.4

### SUCTION LINE PIPING

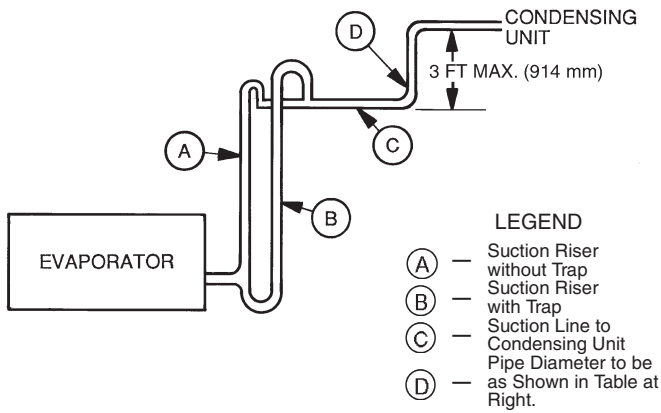

38AP UNIT SIZE	D PIPE DIAMETER					
	DUAL CIRCUIT				SINGLE CIRCUIT	
	CIRCUIT A		CIRCUIT B			
IN.	MM	IN.	MM	IN.	MM	
025	1 <sup>1</sup> / <sub>8</sub>	29	1 <sup>1</sup> / <sub>8</sub>	29	1 <sup>3</sup> / <sub>8</sub>	35
027	1 <sup>1</sup> / <sub>8</sub>	29	1 <sup>1</sup> / <sub>8</sub>	29	1 <sup>3</sup> / <sub>8</sub>	35
030	1 <sup>1</sup> / <sub>8</sub>	29	1 <sup>1</sup> / <sub>8</sub>	29	1 <sup>3</sup> / <sub>8</sub>	35
040	1 <sup>3</sup> / <sub>8</sub>	35	1 <sup>1</sup> / <sub>8</sub>	29	1 <sup>5</sup> / <sub>8</sub>	41
050	1 <sup>3</sup> / <sub>8</sub>	35	1 <sup>3</sup> / <sub>8</sub>	35	1 <sup>5</sup> / <sub>8</sub>	41
060	1 <sup>3</sup> / <sub>8</sub>	35	1 <sup>5</sup> / <sub>8</sub>	41	—	—
065	—	—	—	—	2 <sup>1</sup> / <sub>8</sub>	54
070	1 <sup>5</sup> / <sub>8</sub>	41	1 <sup>5</sup> / <sub>8</sub>	41	—	—
080	1 <sup>5</sup> / <sub>8</sub>	41	1 <sup>5</sup> / <sub>8</sub>	41	—	—
090	1 <sup>5</sup> / <sub>8</sub>	41	1 <sup>5</sup> / <sub>8</sub>	41	—	—
100	1 <sup>5</sup> / <sub>8</sub>	41	1 <sup>5</sup> / <sub>8</sub>	41	—	—
115	1 <sup>5</sup> / <sub>8</sub>	41	2 <sup>1</sup> / <sub>8</sub>	54	—	—
130	1 <sup>5</sup> / <sub>8</sub>	41	2 <sup>1</sup> / <sub>8</sub>	54	—	—



## Commercial Air-Cooled Condensing Units with Puron® Refrigerant (R-410A)

### HVAC Guide Specifications

Size Range: **25 to 130 Nominal Tons at 60 Hz**

**88 to 457 Nominal kW at 60 Hz**

**21 to 108 Nominal Tons at 50 Hz**

**73 to 381 Nominal kW at 50 Hz**

Carrier Model Number: **38APD, 38APS**

### Part 1 — General

#### 1.01 SYSTEM DESCRIPTION

Outdoor-mounted, air-cooled condensing unit with Puron® refrigerant (R-410A) suitable for on-the-ground or rooftop installation. The 38APS unit shall have one refrigeration circuit and shall consist of two or three rotary scroll compressors. The 38APD unit shall have two independent refrigeration circuits and shall consist of two, four, five or six rotary scroll compressors. Unit shall have air-cooled coils, propeller-type condenser fans, a control box, and shall discharge condenser air vertically upward as shown on certified drawings. Unit shall be used in refrigeration circuit with a central station air-handling unit or direct-expansion coils.

#### 1.02 QUALITY ASSURANCE

- A. Unit performance shall be rated in accordance with AHRI (Air-Conditioning, Heating, and Refrigeration Institute) Standard 365, latest edition (U.S.A).
- B. Unit construction shall comply with latest edition of ASHRAE (American Society of Heating, Refrigerating, and Air-Conditioning Engineers) 15 Safety Code, UL 1995, and ASME (American Society of Mechanical Engineers) applicable codes (U.S.A. codes).
- C. Unit shall be manufactured in a facility registered to ISO (International Organization for Standardization) 9001 Manufacturing Quality Standard.
- D. Base unit shall be constructed in accordance with UL (Underwriters Laboratories) standards and CSA (Canadian Standards Association).
- E. Unit cabinet shall be capable of withstanding 500-hour salt-spray exposure per ASTM (American Society for Testing and Materials) B117 (scribed specimen).
- F. Design pressure shall be 650 psig (4482 kPa).
- G. Unit shall be functional checked at the factory.

#### 1.03 DELIVERY, STORAGE, AND HANDLING

Unit shall be shipped as single package and shall be stored and handled per unit manufacturer's recommendations.

#### 1.04 WARRANTY (FOR INCLUSION BY SPECIFYING ENGINEER)

### Part 2 — Products

#### 2.01 EQUIPMENT

##### A. General:

Factory assembled, single-piece, air-cooled condensing unit. Contained within the unit enclosure shall be all factory wiring, piping, controls, compressors, nitrogen holding charge, and special features required prior to field start-up.

##### B. Unit Cabinet:

1. Cabinet shall be galvanized steel casing with a baked enamel powder or pre-painted finish.
2. Cabinet shall be capable of withstanding 500-hr salt spray test in accordance with ASTM (U.S.A.) B-117 standard.
3. Control box access panels shall be hinged for service access.
4. Lifting holes shall be provided to facilitate rigging.

##### C. Fans:

1. Condenser fans shall be direct-drive propeller type, discharging air vertically upward.
2. All condenser fan motors shall be totally enclosed 3-phase type with permanently lubricated ball bearings, class F insulation and internal, automatic-reset thermal overload protection or manual reset calibrated circuit breakers.
3. Shafts shall have inherent corrosion resistance.
4. Fan blades shall be statically and dynamically balanced.
5. Condenser-fan openings shall be equipped with PVC-coated steel wire safety guards.

##### D. Compressors:

1. Compressors shall be rotary scroll.
2. Operating oil charge and a crankcase heater control oil dilution.
3. Compressors shall be mounted on two rails having rubber in shear vibration isolators.
4. Staging of compressors shall provide unloading capability. Digital compressor unloading control shall be available as an option on one circuit (not available on size 065 unit).
5. Compressor motors shall be cooled by refrigerant gas passing through motor windings and shall have either internal line break thermal and current overload protection or external current overload modules with compressor temperature sensors.

##### E. Condenser Coils:

1. Coil shall be air-cooled microchannel heat exchanger (MCHX) and shall have a series of flat tubes containing a series of multiple, parallel flow microchannels layered between the refrigerant manifolds. Microchannel coils shall consist of a two-pass arrangement. Coil construction shall consist of aluminum alloys for the

fins, tubes and manifolds in combination with a corrosion-resistant coating on the tubes.

2. Tubes shall be cleaned, dehydrated, and sealed.
3. Assembled condenser coils shall be leak tested and pressure tested at 650 psig (4482 kPa).

#### F. Refrigeration Components:

1. Refrigeration circuit components shall include liquid line temperature relief device, pressure transducers, liquid line shutoff valve, suction shutoff valve, suction line accumulators, nitrogen holding charge, and compressor oil.
2. Long line length check valves are required for liquid line installation on all linear line length applications of more than 100 ft (30.5 m) to prevent liquid migration during unit shutdown. For any 025-030 size dual circuit unit application where evaporator is located higher than the condensing unit, check valves are required for linear line length above 55 ft (16.8 m).
3. Units shall include one factory-installed suction line accumulator for each refrigerant circuit.

#### G. Controls and Safeties:

1. Unit *ComfortLink* controls shall include:
  - a. Scrolling marquee display module shall be used for accessing condensing unit information, reading sensor values, and testing the condensing unit. The scrolling marquee display is a 4-key, 4-character, 16-segment LED (light-emitting diode) display. Eleven mode LEDs shall be located on the display as well as an Alarm Status LED. The display shows all of the *ComfortLink* control codes (with 60-character expandable clear language), plus set points, time of day, temperatures, pressures, and superheat. Additional information can be displayed all at once with the accessory Navigator™ display.
  - b. Carrier Comfort Network® (CCN) system capability.
  - c. Unit control with standard pressure transducer, discharge pressure transducer and suction temperature thermistors.
  - d. Current alarm list and alarm history list on display.
  - e. Automatic compressor lead/lag control.
  - f. Service run test capability.
  - g. Compressor minimum run time (3 minutes) and minimum off time (3 minutes).
  - h. Service diagnostic mode.
  - i. Self-contained low voltage control circuit.
  - j. Cycle condenser fans to maintain proper head pressure control.
  - k. Capacity control with staging compressors.
  - l. Optional digital scrolls to stage compressors and cycle digital compressor for maintaining desired leaving air temperature set point.

m. Alarm relay output to indicate when unit is in alarm condition.

#### 2. Minimum unit safety devices shall include:

Solid-state compressor lockout to provide optional reset capability at the space thermostat if any of the following safety devices trip and shut off compressor.

- a. Compressor lockout protection for internal or external overload.
- b. Low pressure protection.
- c. High pressure protection (high pressure switch or internal).
- d. Compressor reverse rotation protection.
- e. Loss of charge protection.
- f. Low suction superheat protection.
- g. Short cycle protection.
- h. Suction and discharge pressure transducers.
- i. Circuit breakers or fuses for short circuit protection of compressors.

#### H. Operating Characteristics:

1. The capacity of the condensing unit shall meet or exceed \_\_\_ Btuh (\_\_\_kW) at a suction temperature of \_\_\_ F (\_\_\_C). The power consumption at full load shall not exceed \_\_\_Btuh (\_\_\_kW).
2. The combination of the condensing unit and the evaporator or air-handling unit shall have a total net cooling capacity of \_\_\_ Btuh (\_\_\_kW) or greater at conditions of \_\_\_ cfm (\_\_\_L/s) entering-air temperature at the evaporator at \_\_\_F (\_\_\_C) wet bulb and \_\_\_F (\_\_\_C) dry bulb, and air entering the condensing unit at \_\_\_F (\_\_\_C).
3. The system shall have an Energy Efficiency Ratio (EER) of \_\_\_Btuh/watt or greater at standard AHRI conditions.

#### I. Electrical Requirements:

All unit power wiring shall enter unit cabinet at a single location (115 and 130 size units available with dual point power with terminal block).

#### J. Special Features:

1. Low Ambient Control:
  - a. Control shall regulate fan motor speed in response to the saturated condensing temperature of the unit. The control shall be capable of operating with outdoor temperatures at -20 F (-28.9 C).
  - b. Motormaster® low ambient control shall be available as a factory-installed option or field-installed accessory for all units.
2. Optional E-Coated MCHX Condenser Coil:
 

E-coated aluminum microchannel coils shall have a flexible epoxy polymer coating uniformly applied to all coil external surface areas without material bridging between fins or louvers. Coating process shall ensure complete coil

encapsulation, including all exposed fin edges. E-coat thickness of 0.8 to 1.2 mil with top coat having a uniform dry film thickness from 1.0 to 2.0 mil on all external coil surface areas, including fin edges, shall be provided. E-coated coils shall have superior hardness characteristics of 2H per ASTM D3363-00 and cross-hatch adhesion of 4B-5B per ASTM D3359-02. E-coated products shall have superior impact resistance with no cracking, chipping or peeling per NSF/ANSI (National Sanitation Foundation/American National Standards Institute) 51-2002 Method 10.2 (U.S.A. Standards). E-coated aluminum microchannel coils shall be capable of withstanding an 8,000-hour salt spray test in accordance with the ASTM (American Society for Testing and Materials) (U.S.A.) B-117 Standard.

### 3. Sound Reduction:

- a. Low sound fan for sound reduction is available as a factory-installed option or field-installed accessory for all units.
- b. Low sound compressor blankets for additional sound reduction are available as a factory-installed option on all units having low sound fans or as a field-installed accessory.

### 4. Digital Compressor Option:

Modification shall include digital compressor to provide incremental steps for tighter temperature control. The digital compressor shall be available as a factory-installed option for all units except size 065.

### 5. Non-Fused Disconnect:

A non-fused disconnect is available as a factory-installed option for all units having single point power connection units.

### 6. Long Line Length Check Valves:

Long line length check valves are available as options shipped with the unit or accessories shipped separately. In either case, field installation is required.

### 7. High Short Circuit Current Rating (SCCR):

The optional high SCCR interrupt capability shall allow the unit to tolerate a 65 kA (208/230v, 380v and 460-v units) or 25 kA (575-v units) short circuit current for a brief period of time while protecting downstream components. The high SCCR option shall provide a higher level of protection than the standard unit (option for 60 Hz only). High interrupt shall be available as factory-installed option on all units.

### 8. Navigator™ Hand Held Display:

- a. Portable hand held display module with a minimum of 4 lines and 20 characters per line, of clear English, French, Spanish, or Portuguese language.
- b. Display menus shall provide clear language descriptions of all menu items, operating

modes, configuration points and alarm diagnostics. Reference to factory codes shall not be accepted.

- c. RJ-14 connection plug shall allow display module to be connected to factory-installed receptacle.
  - d. Industrial grade coiled extension cord shall allow the display module to be moved around the unit.
  - e. Magnets shall hold the display module to any sheet metal panel to allow hands-free operation.
  - f. Display module shall have NEMA (National Electrical Manufacturers Association, U.S.A.) 4x housing suitable for use in outdoor environments.
  - g. Display shall have back light and contrast adjustment for easy viewing in bright sunlight or night conditions.
  - h. Navigator module shall have raised surface buttons with positive tactile response.
  - i. Navigator module shall be available as field-installed accessory for all units.
9. BACnet Communication Option:  
The BACnet Communication option shall provide factory-installed communication capability with a BACnet MS/TP network. Allows integration with i-Vu® Open control system or a BACnet building automation system.
10. BACnet Translator Control:  
BACnet control shall be available as a field-installed accessory for all units to provide interface between unit and a BACnet Local Area Network (LAN, i.e., MS/TP EIA-485).
11. LON Translator Control:  
Unit shall be supplied with field-installed interface between the chiller and a Local Operating Network (LON, i.e., LonWorks FT-10A ANSI/EIA-709.1). LON shall be available as a field-installed accessory for all units.
12. Touch Pilot™ Display:  
Touch Pilot remote mount touch screen display for network attachment to the unit shall be available as a field-installed accessory for all units.
13. Energy Management Module (EMM):  
The EMM shall provide remote set point, demand limit control, and percent capacity input. The EMM is not needed with use of BACnet or LON accessory kit.
14. Remote Enhanced Display Accessory Kit:  
The remote enhanced display accessory kit shall contain a remotely mounted 40-character per line, 16-line display panel for unit diagnostics.

15. Security Grilles/Hail Guards:

Units shall be supplied with factory-installed or field-installed louvered, sheet metal panels which securely fasten to the unit to provide condenser coil protection against hail and physical damage.

16. Vibration Isolation Pads:

Neoprene vibration isolation pads (24 in. x 3 in. x 1/4 in.) shall be available for field installation to reduce vibration transmission from the compressor through the floor and into the conditioned space.

17. Wind Baffle Kit:

Field-installed accessory kit shall provide wind baffles for use with low ambient temperature operation.

18. Seismic Certification:

A seismic kit is available which will result in a unit SDS (seismic design acceleration parameter) level of 2.5 for 38AP025-065 units and 2.1 for 38AP070-130 units.







