



Turn to the experts

Product Data

WeatherMaster®

Packaged Rooftop Units

15 to 25 Nominal Tons

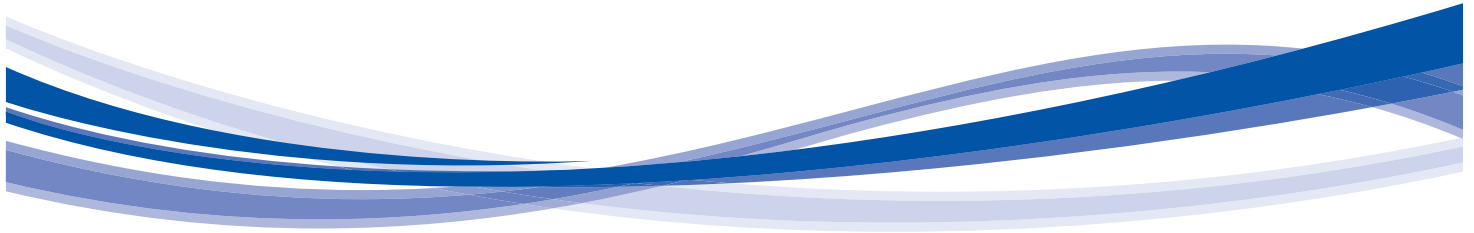

WeatherMaster®



Unit shown with optional EnergyX® System

50HC Sizes 17, 20, 24, 28

Packaged Rooftop Units, Cooling Only with Optional Electric Heat, Optional EnergyX® Energy Recovery Device, and ComfortLink Controls

Carrier WeatherMaster® 15 to 25 Ton rooftop unit (RTU) was designed by customers for customers. With “no-strip” screw collars, handled access panels, and more we’ve made your unit easy to install, easy to maintain, easy to use and reliable.

Easy to install

These WeatherMaster units are designed for dedicated factory-supplied vertical or horizontal air flow duct configurations. No special field kits are required. Designed to fit on pre-installed curbs by another manufacturer, these units also fit on past designed Carrier installed curbs with a new certified and authorized adapter curb. This cabinet design also integrates a large control box that gives you room to work and room to mount Carrier accessory controls.

Easy to maintain

Easy access handles by Carrier provide quick and easy access to all normally serviced components. Our “no-strip” screw system has superior holding power and guides screws into position while preventing the screw from stripping the unit’s metal. Take accurate pressure readings by reading condenser pressure with panels in place as compressors are strategically located to eliminate any air bypass.

Easy to use

The newly designed, central terminal board by Carrier puts all your connections and troubleshooting points in one convenient place, standard. Most low voltage connections are made to the same board and make it easy to find what you’re looking for and easy to access it.

Reliable

Each unit comes with precision sized and tested scroll compressor that is internally protected from over temperature and pressures. In addition, each refrigerant circuit is further protected with a high pressure and low pressure switch as well as containing a liquid line filter drier. Each unit is factory tested prior to shipment to help ensure unit’s operation once properly installed.

Key features

- Optional EnergyX® system with energy recovery ventilator (ERV) (vertical airflow units only).
- Two stage cooling capacity with independent circuits and control.

- High performance copper tube/aluminum plate fin (RTPF) condenser and evaporator coils with optional coating.
- EERs up to 12.2.
- IEERs up to 13.4 with single speed indoor fan motor and up to 14.0 with SAV™ (Staged Air Volume) 2-speed/VFD indoor fan motor.
- Dedicated vertical and horizontal air flow duct configuration models. No field kits required.
- Utility connections through the side or bottom. Bottom connections are also in an enclosed environment to help prevent water entry. Field supplied couplings are required.
- Standardized components and control box layout. Standardized components and controls make stocking parts and service easier.
- Scroll compressors on all units. This makes service, stocking parts, replacement, and troubleshooting easier.
- Precision sized TXV metering device on each refrigerant circuit.
- Easy-adjust, belt-drive motor available. Motor assembly also contains a fan belt break protection system on all models and reliable pillow block bearing system that allows lubrication thru front of the unit.
- Capable of thru-the-base or thru-the-curb electrical routing.
- Full range of electric heaters and single point electric kits — pre-engineered and approved for field installation.
- Single-point electrical connection.
- Sloped, composite drain pan sheds water; and won’t rust.
- Standardized controls and control box layout. Standardized components and controls make stocking parts and service easier.
- Clean, large, easy to use control box.
- Color-coded wiring.
- Large, laminated wiring and power wiring drawings which are affixed to unit make troubleshooting easy.
- Single, central terminal board for test and wiring connections.
- Fast-access, handled, panels for easy access on normally accessed service panels.
- “No-strip” screw system guides screws into the panel and captures them tightly without stripping the screw, the panel, or the unit.
- Mechanical cooling 125°F to 35°F (52°C to 2°C) standard on all models. Low ambient controller allows operation down to -20°F (-29°C).
- 2-in. (51 mm) disposable filters on all units, with 4-in. (102 mm) filter track - field-installed.
- Refrigerant filter-drier on each circuit.
- High and low pressure switches. Added reliability with high pressure switch and low pressure switch.
- Many factory-installed options ranging from air management economizers, 2 position dampers, manual outdoor air dampers, plus convenience outlets, disconnect switch and smoke detectors.
- Factory-installed Humidi-MiZer® adaptive dehumidification system on all sizes, includes Motormaster® controller.
- Standard Parts Warranty: 5 year compressor, 5 year electric heater, 1 year others.
- Optional Staged Air Volume (SAV) system utilizes a Variable Frequency Drive (VFD) to automatically adjust the indoor fan motor speed between cooling stages. Available on models with electromechanical, ComfortLink or RTU Open controls.

Table of contents

Features/Benefits	2
Model Number Nomenclature	3
Capacity Ratings	4
Physical Data	6
Options and Accessories	9
Base Unit Dimensions	14
Accessory Dimensions	41
Performance Data	44
Fan Data	57
Typical Wiring Diagram	69
Electrical Data	74
Sequence of Operation	87
Application Data	90
Guide Specifications	95

Model number nomenclature



50HC MODEL NUMBER NOMENCLATURE (EXAMPLE)

50 HC - D 24 A 3 A 5 - 0 A 0 A 0

Unit Heat Type

50 - Electric Heat Packaged Rooftop

Model Series - WeatherMaster®

HC - High Efficiency

Electric Heat Options

- = Standard, No Electric Heat
 A = Low Electric Heat
 B = Medium Electric Heat
 C = High Electric Heat

Refrig. Systems Options

D = Two stage cooling models
 E = Two stage cooling models with Humidi-MiZer® System
 G = Two stage cooling models with Motormaster® Low Ambient controller

Cooling Tons

17 = 15 tons
 20 = 17.5 tons
 24 = 20 tons
 28 = 25 tons

Sensor Options

A = None
 B = RA Smoke Detector
 C = SA Smoke Detector
 D = RA + SA Smoke Detector
 E = CO₂
 F = RA Smoke Detector and CO₂
 G = SA Smoke Detector and CO₂
 H = RA + SA Smoke Detector and CO₂
 J = Condensate Overflow Switch
 K = Condensate Overflow Switch and RA Smoke Detectors
 L = Condensate Overflow Switch and RA and SA Smoke Detectors

Indoor Fan Options & Air Flow Configuration

1 = Standard Static/Vertical Supply, Return Air Flow
 2 = Medium Static/Vertical Supply, Return Air Flow
 3 = High Static/Vertical Supply, Return Air Flow
 B = Medium Static, High Efficiency Motor/Vertical Supply, Return Air Flow
 C = High Static, High Efficiency Motor/Vertical Supply, Return Air Flow
 5 = Standard Static/Horizontal Supply, Return Air Flow
 6 = Medium Static/Horizontal Supply, Return Air Flow
 7 = High Static/Horizontal Supply, Return Air Flow
 F = Medium Static, High Efficiency Motor/Horizontal Supply, Return Air Flow
 G = High Static, High Efficiency Motor/Horizontal Supply, Return Air Flow

Coil Options – RTPF (Outdoor - Indoor - Hail Guard)

A = Al/Cu - Al/Cu
 B = Precoat Al/Cu - Al/Cu
 C = E-coat Al/Cu - Al/Cu
 D = E-coat Al/Cu - E-coat Al/Cu
 E = Cu/Cu - Al/Cu
 F = Cu/Cu - Cu/Cu
 M = Al/Cu - Al/Cu — Louvered Hail Guard
 N = Precoat Al/Cu - Al/Cu — Louvered Hail Guard
 P = E-coat Al/Cu - Al/Cu — Louvered Hail Guard
 Q = E-coat Al/Cu - E-coat Al/Cu — Louvered Hail Guard
 R = Cu/Cu - Al/Cu — Louvered Hail Guard
 S = Cu/Cu - Cu/Cu — Louvered Hail Guard

Packaging

0 = Standard
 3 = California Seismic Compliant - OSHPD

Electrical Options

A = None
 B = HACR Breaker
 C = Non-Fused Disconnect
 G = 2-Speed Indoor Fan (VFD) Controller
 J = 2 Speed Fan Controller (VFD) & Non-Fused Disconnect

Service Options

0 = None
 1 = Unpowered Convenience Outlet
 2 = Powered Convenience Outlet
 3 = Hinged Panels
 4 = Hinged Panels & Unpowered Convenience Outlet
 5 = Hinged Panels & Powered Convenience Outlet
 C = Foil Faced Insulation
 Q = EnergyX® Only
 R = EnergyX with Economizer Only
 S = EnergyX with Frost Protection Only
 T = EnergyX with Economizer and Frost Protection

Intake / Exhaust Options

A = None
 B = Temperature Economizer w/ Barometric Relief
 F = Enthalpy Economizer w/ Barometric Relief
 K = 2-Position Damper
 U = Temp Ultra Low Leak Economizer w/ Barometric Relief
 V = Temp Ultra Low Leak Economizer w/ Power Exhaust
 - Vertical Air Only
 W = Enthalpy Ultra Low Leak Economizer w/ Barometric Relief
 X = Enthalpy Ultra Low Leak Economizer w/ Power Exhaust
 - Vertical Air Only

Base Unit Controls

0 = Electro-mechanical Controls. Can be used with W7212 EconoMiSer® IV (Non-Fault Detection and Diagnostic)
 1 = PremierLink™ Controller
 2 = RTU Open Multi-Protocol Controller
 6 = Electro-mechanical w/ 2-Speed Fan and W7220 Economizer Controller. Can be used with W7220 EconoMiSer X (with Fault Detection and Diagnostic)
 D = ComfortLink Controls

Design Revision

- = Factory Design Revision

Voltage

1 = 575/3/60
 5 = 208-230/3/60
 6 = 460/3/60

NOTE: Not all possible options are displayed. See the current 50HCX 15 to 25 Ton Price Pages for more details.

* On 50HC horizontal airflow and all 50HC units equipped with the EnergyX option electric heat is only available as a field-installed accessory.



AHRI RATINGS (2-STAGE COOLING)

50HC UNIT	COOLING STAGES	NOM. CAPACITY (TONS)	NET COOLING CAPACITY (MBH)	CONFIGURATION	TOTAL POWER (kW)	ELECTRIC HEAT OPTIONS	EER	IEER W/ SINGLE SPEED INDOOR FAN	IEER W/ 2-SPEED INDOOR FAN
17	2	15	174	Vertical	14.3	All	12.2	13.2	13.7
				Horizontal	14.7	None	11.8	12.4	13.4
					14.7	Low	11.8	12.4	13.4
					14.7	Med	11.8	12.4	13.4
					14.9	High	11.7	12.3	13.3
20	2	17.5	202	Vertical	16.6	All	12.2	13.2	13.8
				Horizontal	17.3	None	11.7	12.4*	13.5
					17.6	Low	11.5	12.0	13.4
					17.7	Med	11.4	11.9	13.3
					17.9	High	11.3	11.5	13.2
24	2	20	232	Vertical	19.0	All	12.2	13.4	14.0
				Horizontal	19.7	None	11.8	12.9	13.5
					20.0	Low	11.6	12.5	13.4
					20.0	Med	11.6	12.4	13.4
					20.5	High	11.3	12.0	13.3
28	2	25	282	Vertical	24.7	All	11.4	12.2	12.7
				Horizontal	25.9	None	10.9	11.3	12.4
					25.9	Low	10.9	N/A	12.3
					26.1	Med	10.8	N/A	12.2
					26.6	High	10.6	N/A	11.9

LEGEND

- AHRI** — Air-Conditioning, Heating and Refrigeration Institute
ASHRAE — American Society of Heating, Refrigerating and Air-Conditioning Engineers
EER — Energy Efficiency Ratio
IECC — International Energy Conservation Code
IEER — Integrated Energy Efficiency Ratio

*50HC20, horizontal, single speed, no heating, rated at 5600 cfm.



NOTES:

- Rated and certified under AHRI Standard 340/360, as appropriate.
- Ratings are based on:
Cooling Standard: 80°F (27°C) db, 67°F (19°C) wb indoor air temp and 95°F db outdoor air temp.
IEER Standard: A measure that expresses cooling part-load EER efficiency for commercial unitary air conditioning and heat pump equipment on the basis of weighted operation at various load capacities.
- All 50HC units comply with DOE-2018, ASHRAE 90.1-2016 and IECC¹-2015 minimum efficiency requirements when equipped with SAV (staged air volume) option.

1. IECC is a registered trademark of International Code Council inc.

SOUND RATINGS TABLE

50HC UNIT	COOLING STAGES	OUTDOOR SOUND (dB) AT 60 Hz											
		A-Weighted	Linear	AHRI-370 Rating	31.5	63	125	250	500	1000	2000	4000	8000
17	2	84.1	96.2	84	92.6	92.2	83.9	80.4	81.8	78.7	76.5	72.2	65.4
20	2	84.1	96.2	84	92.6	92.2	83.9	80.4	81.8	78.7	76.5	72.2	65.4
24	2	86.5	99.6	87	96.2	95.6	87.5	84.2	84.2	81.7	77.9	73.2	66.3
28	2	85.9	103.0	86	101.3	97.1	88.3	84.4	83.3	80.7	77.4	73.4	67.3

LEGEND

dB — Decibel

NOTES:

- Outdoor sound data is measured in accordance with AHRI.
- Measurements are expressed in terms of sound power. Do not compare these values to sound pressure values because sound

pressure accounts for specific environmental factors which do not match individual applications. Sound power values are independent of the environment and therefore more accurate.

- A-weighted sound ratings filter out very high and very low frequencies, to better approximate the response of an "average" human ear. A-weighted measurements for Carrier units are taken in accordance with AHRI standard 370.



MINIMUM - MAXIMUM AIRFLOW RATINGS (CFM) COOLING AND ELECTRIC HEAT

50HC MODEL SIZE	NOMINAL (kW)	ELECTRIC HEATERS		COOLING			
		MINIMUM	MAXIMUM	MINIMUM SINGLE SPEED FAN MOTOR	MINIMUM 2-SPEED FAN MOTOR (AT HIGH SPEED)	MINIMUM 2-SPEED FAN MOTOR (AT LOW SPEED)	MAXIMUM
17	25	4500	7500	4500	5070	3346	7500
	50						
	75						
20	25	5200	9000	5250	5915	3904	9000
	50						
	75						
24	25	6000	10000	6000	7500	4950	10000
	50						
	75						
28	25	7000	12500	7500	8450	5577	12500
	50						
	75						

50HC 15 TO 25 TON PHYSICAL DATA

		50HC**17	50HC**20	50HC**24	50HC**28
REFRIGERATION SYSTEM					
# Circuits / # Comp. / Type		2 / 2 / Scroll	2 / 2 / Scroll	2 / 2 / Scroll	2 / 2 / Scroll
R-410A Charge A/B (lbs)		17/16.4	17.5/16.8	23.8/23.1	24.9/27.7
w/ Humidi-MiZer® R-410A Charge A/B (lbs)		24.5/25.7	25.5/25.5	30.0/30.7	35.1/35.4
Metering device		TXV	TXV	TXV	TXV
High-press. Trip / Reset (psig)		630/505	630/505	630/505	630/505
Low-press. Trip / Reset (psig)		54/117	54/117	54/117	54/117
w/Humidi-MiZer, Low-press. Trip / Reset (psig)		27 / 44	27 / 44	27 / 44	27 / 44
EVAP. COIL					
Material		Cu / Al	Cu / Al	Cu / Al	Cu / Al
Tube Diameter		3/8-in. RTPF	3/8-in. RTPF	3/8-in. RTPF	3/8-in. RTPF
Rows / FPI		4/15	4/15	4/15	4/15
Total face area (ft ²)		22	22	26	26
Condensate drain conn. size		3/4-in.	3/4-in.	3/4-in.	3/4-in.
HUMIDI-MIZER COIL					
Material		Cu / Al	Cu / Al	Cu / Al	Cu / Al
Tube Diameter		3/8-in. RTPF	3/8-in. RTPF	3/8-in. RTPF	3/8-in. RTPF
Rows / FPI		1/17	1/17	1/17	1/17
Total face area (ft ²)		22	22	26	26
EVAPORATOR FAN AND MOTOR VERTICAL					
Standard Static	Motor Qty / Belt Qty / Drive type	1 / 1 / Belt	1 / 1 / Belt	—	1 / 1 / Belt
	Max BHP	2.9	3.7	—	4.9
	RPM range	514-680	622-822	—	717-911
	Motor frame size	56	56	—	56
	Fan Qty / Type	2 / Centrifugal	2 / Centrifugal	—	2 / Centrifugal
	Fan Diameter (in.)	15 x 15	15 x 15	—	15 x 15
Medium Static	Motor Qty / Belt Qty / Drive type	1 / 1 / Belt	1 / 1 / Belt	—	—
	Max BHP	3.7	4.9	—	—
	RPM range	679-863	713-879	—	—
	Motor frame size	56	56	—	—
	Fan Qty / Type	2 / Centrifugal	2 / Centrifugal	—	—
	Fan Diameter (in.)	15 x 15	15 x 15	—	—
High Static	Motor Qty / Belt Qty / Drive type	1 / 1 / Belt	—	—	—
	Max BHP	4.9	—	—	—
	RPM range	826-1009	—	—	—
	Motor frame size	56	—	—	—
	Fan Qty / Type	2 / Centrifugal	—	—	—
	Fan Diameter (in.)	15 x 15	—	—	—
Standard Static High Efficiency	Motor Qty / Belt Qty / Drive type	—	—	1 / 1 / Belt	—
	Max BHP	—	—	6.5/6.9/7.0/8.3	—
	Max BHP (208/230/460/575v)	—	—	690-863	—
	Motor frame size	—	—	184T	—
	Fan Qty / Type	—	—	2 / Centrifugal	—
	Fan Diameter (in.)	—	—	15 x 15	—
Medium Static High Efficiency	Motor Qty / Belt Qty / Drive type	—	—	1 / 1 / Belt	1 / 1 / Belt
	Max BHP (208/230/460/575v)	—	—	6.5/6.9/7.0/8.3	6.5/6.9/7.0/8.3
	RPM range	—	—	835-1021	913-1116
	Motor frame size	—	—	184T	184T
	Fan Qty / Type	—	—	2 / Centrifugal	2 / Centrifugal
	Fan Diameter (in.)	—	—	15 x 15	15 x 15



50HC 15 TO 25 TON PHYSICAL DATA (cont)

		50HC**17	50HC**20	50HC**24	50HC**28
High Static High Efficiency	Motor Qty / Belt Qty / Drive type	—	1 / 1 / Belt	1 / 1 / Belt	1 / 1 / Belt
	Max BHP (208/230/460/575v)	—	6.5/6.9/7.0/8.3	10.5/11.9/11.9/11.0	10.5/11.9/11.9/11.0
	RPM range	—	882-1078	941-1176	941-1176
	Motor frame size	—	184T	213T	213T
	Fan Qty / Type	—	2 / Centrifugal	2 / Centrifugal	2 / Centrifugal
	Fan Diameter (in.)	—	15 x 15	15 x 15	15 x 15
EVAPORATOR FAN AND MOTOR HORIZONTAL					
Standard Static	Motor Qty / Belt Qty / Drive type	1 / 1 / Belt	1 / 1 / Belt	N/A	1 / 1 / Belt
	Max BHP	2.9	3.7	N/A	4.9
	RPM range	514-680	622-822	N/A	647-791
	Motor frame size	56	56	N/A	56
	Fan Qty / Type	2 / Centrifugal	2 / Centrifugal	N/A	2 / Centrifugal
	Fan Diameter (in.)	18 x 15/15 x 11	18 x 15/15 x 11	N/A	18 x 15/15 x 11
Medium Static	Motor Qty / Belt Qty / Drive type	1 / 1 / Belt	1 / 1 / Belt	N/A	N/A
	Max BHP	3.7	4.9	N/A	N/A
	RPM range	614-780	713-879	N/A	N/A
	Motor frame size	56	56	N/A	N/A
	Fan Qty / Type	2 / Centrifugal	2 / Centrifugal	N/A	N/A
	Fan Diameter (in.)	18 x 15/15 x 11	18 x 15/15 x 11	N/A	N/A
High Static	Motor Qty / Belt Qty / Drive type	1 / 1 / Belt	N/A	N/A	N/A
	Max BHP	4.9	N/A	N/A	N/A
	RPM range	746-912	N/A	N/A	N/A
	Motor frame size	56	N/A	N/A	N/A
	Fan Qty / Type	2 / Centrifugal	N/A	N/A	N/A
	Fan Diameter (in.)	18 x 15/15 x 11	N/A	N/A	N/A
Standard Static High Efficiency	Motor Qty / Belt Qty / Drive type	N/A	N/A	1 / 1 / Belt	N/A
	Max BHP	N/A	N/A	6.5/6.9/7.0/8.3	N/A
	Max BHP (208/230/460/575v)	N/A	N/A	690-863	N/A
	Motor frame size	N/A	N/A	184T	N/A
	Fan Qty / Type	N/A	N/A	2 / Centrifugal	N/A
	Fan Diameter (in.)	N/A	N/A	18 x 15/15 x 11	N/A
Medium Static High Efficiency	Motor Qty / Belt Qty / Drive type	N/A	N/A	1 / 1 / Belt	1 / 1 / Belt
	Max BHP (208/230/460/575v)	N/A	N/A	6.5/6.9/7.0/8.3	6.5/6.9/7.0/8.3
	RPM range	N/A	N/A	835-1021	755-923
	Motor frame size	N/A	N/A	184T	184T
	Fan Qty / Type	N/A	N/A	2 / Centrifugal	2 / Centrifugal
	Fan Diameter (in.)	N/A	N/A	18 x 15/15 x 11	18 x 15/15 x 11
High Static High Efficiency	Motor Qty / Belt Qty / Drive type	N/A	1 / 1 / Belt	1 / 1 / Belt	1 / 1 / Belt
	Max BHP (208/230/460/575v)	N/A	6.5/6.9/7.0/8.3	10.5/11.9/11.9/11.0	10.5/11.9/11.9/11.0
	RPM range	N/A	835-1021	941-1100	906-1100
	Motor frame size	N/A	184T	213T	213T
	Fan Qty / Type	N/A	2 / Centrifugal	2 / Centrifugal	2 / Centrifugal
	Fan Diameter (in.)	N/A	18 x 15/15 x 11	18 x 15/15 x 11	18 x 15/15 x 11
COND. COIL (CIRCUIT A)					
Coil type	RTPF	RTPF	RTPF	RTPF	
Coil Length (in.)	70	72	82	95	
Coil Height (in.)	44	44	52	52	
Rows / FPI (fins per inch)	2 / 17	2 / 17	2 / 17	2 / 17	
Total face area (ft ²)	21.4	22.0	29.6	34.3	
COND. COIL (CIRCUIT B)					
Coil type	RTPF	RTPF	RTPF	RTPF	
Coil Length (in.)	70	64	80	95	
Coil Height (in.)	44	44	52	52	
Rows / FPI (fins per inch)	2 / 17	2 / 17	2 / 17	2 / 17	
Total face area (ft ²)	21.4	19.5	29.6	34.3	

Physical data (cont)



50HC 15 TO 25 TON PHYSICAL DATA (cont)

	50HC**17	50HC**20	50HC**24	50HC**28
COND. FAN/MOTOR				
Qty / Motor drive type	3 / direct	4 / direct	4 / direct	6 / direct
Motor HP / RPM	1/4 / 1100	1/4 / 1100	1/4 / 1100	1/4 / 1100
Fan diameter (in.)	22	22	22	22
FILTERS				
RA Filter # / size (in.)	6 / 20 x 25 x 2	6 / 20 x 25 x 2	9 / 16 x 25 x 2	9 / 16 x 25 x 2
OA inlet screen # / size (in.)	4 / 16 x 25 x 1	4 / 16 x 25 x 1	4 / 16 x 25 x 1	4 / 16 x 25 x 1
EnergyX® ENERGY RECOVERY VENTILATOR (ERV)				
EnergyX Economizer Option	NON ECONO CFM	ECONO CFM	NON ECONO CFM	ECONO CFM
EnergyX Unit Type	Modulating Air Flow Capability / Electro-Mechanical Constant Speed		Modulating Air Flow Capability / Electro-Mechanical Constant Speed	
EnergyX Wheel OA (CFM) Range	682-3675		1076-6000	
EnergyX Wheel EA (CFM) Range	682-3675		1076-6000	
EnergyX Recovery Wheel				
Type	Enthalpy Lightweight Polymer with Silica Gel Desiccant Coating		Enthalpy Lightweight Polymer with Silica Gel Desiccant Coating	
Model (AirXchange)	ERC-3628		ERC-4646C	
Size (Diameter x Depth) (in.)	36 x 3		46 x 3	
Nominal Drive Motor HP	1/20		1/6	
EnergyX Supply Fan #1				
QTY — Type	1 - Backward Curved		1 - Backward Curved	
Drive Type	Direct		Direct	
Blower Size (Diameter) (in.)	15.75		19.68	
Nominal Motor HP	1.2		3.6	
EnergyX Supply Fan #2				
QTY — Type	1 - Backward Curved		1 - Backward Curved	
Drive Type	Direct		Direct	
Blower Size (Diameter) (in.)	15.75		19.68	
Nominal Motor HP	1.2		3.6	
EnergyX Exhaust Fan #1				
QTY — Type	1 - Backward Curved		1 - Backward Curved	
Drive Type	Direct		Direct	
Blower Size (Diameter) (in.)	19.68		19.68	
Nominal Motor HP	3.6		3.6	
EnergyX Exhaust Fan #2				
QTY — Type	1 - Backward Curved		1 - Backward Curved	
Drive Type	Direct		Direct	
Blower Size (Diameter) (in.)	19.68		19.68	
Nominal Motor HP	3.6		3.6	
EnergyX Filters				
Type	2-in. Pleated, 30% Efficiency		2-in. Pleated, 30% Efficiency	
Supply Air (QTY) — Size (in.)	(2) 16 x 20 x 2		(2) 20 x 25 x 2	
Exhaust Air (QTY) — Size (in.)	(2) 16 x 20 x 2		(2) 20 x 25 x 2	
Type	Aluminum Water Filter		Aluminum Water Filter	
Water Entrapment (QTY) — Size (in.)	(2) 34.375 x 17.25 x 1		(2) 34.375 x 24.5 x 1	

LEGEND

- BHP** — Brake Horsepower
- EA** — Entering Air
- FPI** — Fins per Inch
- OA** — Outdoor Air
- RTPF** — Round Tube Plate Fin
- TXV** — Thermostatic Expansion Valve

Options and accessories



ITEM	FACTORY INSTALLED OPTION	FIELD INSTALLED ACCESSORY
CABINET		
Dedicated Vertical Air Flow Duct Configuration	X	
Dedicated Horizontal Air Flow Duct Configuration	X	
Hinged Access Panels	X	
COIL OPTIONS		
Cu/Cu (indoor) coils	X	
E-coated indoor & outdoor coils	X	
Pre-coated outdoor coils	X	
HUMIDITY CONTROL		
Humidi-MiZer® Adaptive Dehumidification System	X	
CONDENSER PROTECTION		
Condenser coil hail guard (louvered design)	X	X
CONTROLS		
Thermostats, temperature sensors, and sub-bases		X
PremierLink™ DDC communicating controller ¹	X	X
ComfortLink Controls	X	
RTU Open protocol controller	X	
Smoke detector (supply and/or return air)	X	X
Horn/Strobe Annunciator ²		X
Time Guard II compressor delay control circuit		X
Phase Monitor		X
ECONOMIZERS & OUTDOOR AIR DAMPERS		
EconoMiSer® IV for electro-mechanical controls – Non FDD (Standard air leak damper models) ³	X	X
EconoMiSer2 for DDC controls, complies with FDD (Standard and Ultra Low Leak air damper models) ^{3,4}	X	X
Motorized 2 position outdoor-air damper	X	X
Manual outdoor-air damper (25%)		X
Barometric relief ⁵	X	X
Barometric hood (Horizontal economizer)		X
Power exhaust	X	X
EconoMiSer X for electro-mechanical control, complies with FDD. (Standard and Ultra Low Leak air damper models) ³	X	X
ECONOMIZER SENSORS & IAQ DEVICES		
Single dry bulb temperature sensors ⁶	X	X
Differential dry bulb temperature sensors ⁶		X
Single enthalpy sensors ⁶	X	X
ECONOMIZER SENSORS & IAQ DEVICES (cont)		
Differential enthalpy sensors ⁶		X
CO ₂ sensor (wall, duct, or unit mounted) ⁶	X	X
ELECTRIC HEAT		
Electric Resistance Heaters	X	X
Single Point Kit	X	X

ITEM	FACTORY INSTALLED OPTION	FIELD INSTALLED ACCESSORY
INDOOR MOTOR & DRIVE		
Multiple motor and drive packages	X	
Staged Air Volume (SAV™) system w/VFD controller (2-stage cool only with electrical mechanical and RTU Open controls)	X	
Display Kit for SAV system with VFD		X
LOW AMBIENT CONTROL		
Winter start kit ⁷		X
Motormaster® head pressure controller to -20°F (-29°C) ⁷		X
Cooling Low Ambient Controller to 0°F (-18°C) ⁷	X	
POWER OPTIONS		
Convenience outlet (powered)	X	
Convenience outlet (unpowered): 15 amp factory-installed, 20 amp field-installed	X	X
Non-fused disconnect ⁸	X	
HACR circuit breaker ⁹	X	
ROOF CURBS		
Roof curb 14-in. (356 mm)		X
Roof curb 24-in. (610 mm)		X
Adapter Curb (Adapts to Models – DP/DR/HJ/TM/TJ) ¹⁰		X
EnergyX® SYSTEM		
EnergyX Energy Recovery	X	
EnergyX with Economizer	X	
EnergyX with Frost Protection	X	
EnergyX with Frost Protection and Economizer	X	
Filter Maintenance Sensor		X
Motor Status Sensor		X

NOTES:

- Not available with SAV.
- Requires a field-supplied 24V transformer for each application. See price pages for details.
- FDD (Fault Detection and Diagnostic) capability per California Title 24 section 120.2.
- Models with RTU Open DDC controls comply with California Title 24 Fault Detection and Diagnostic (FDD). PremierLink in non FDD.
- Included with economizer.
- Sensors used to optimize economizer performance.
- See application data for assistance.
- Non-fused disconnect switch cannot be used when FLA electrical rating exceeds 100 amps at 460/575 volt and 200 amps at 208/230 volt. Carrier RTU Builder selects this automatically.
- HACR circuit breaker cannot be used when rooftop MOCP electrical rating exceeds 200 amps at 208/230 volt, 90 amps at 460 volt and 90 amps at 575 volt. 575 volt can only be used on Wye power supply. Delta power supply is prohibited. Carrier RTU Builder selects this automatically.
- Not for 48TJE028-028 models using 48DP900041, 48DP900051 or 48DP900061 roof curbs.

Economizer (dry-bulb or enthalpy)

Economizers can reduce operating costs. They bring in fresh, outside air for ventilation; and provide cool outside air to cool your building. This also is the preferred method of low ambient cooling. When integrated with CO₂ sensors, economizers can provide even more savings by coupling the ventilation air to only that amount required based on space occupancy.

Economizers are available, installed and tested by the factory, with either enthalpy or temperature dry-bulb inputs. There are also models for electromechanical, direct digital controllers and single speed fan or 2-speed indoor fan motors. Additional sensors are available as accessories to optimize the economizer.

Economizers include gravity controlled barometric relief that helps equalize building pressure and ambient air pressures. This can be a cost effective solution to prevent building pressurization. Economizers are available in Ultra Low Leak and standard low leak versions.

CO₂ Sensor

The CO₂ sensor works with the economizer to intake only the correct amount of outside air for ventilation. As occupants fill your building, the CO₂ sensor detects their presence through increasing CO₂ levels, and opens the economizer appropriately.

When the occupants leave, the CO₂ levels decrease, and the sensor appropriately closes the economizer. This intelligent control of the ventilation air, called Demand Controlled Ventilation (DCV), reduces the overall load on the rooftop, saving money.

Smoke Detectors

Trust the experts. Smoke detectors make your application safer and your job easier. Carrier smoke detectors immediately shut down the rooftop unit when smoke is detected. They are available, installed by the factory, for supply air, return air, or both.

Louvered Hail Guards

Sleek, louvered panels protect the condenser coil from hail damage, foreign objects, and incidental contact.

Convenience Outlet (powered or un-powered)

Reduce service and/or installation costs by including a convenience outlet in your specification. Carrier will install this service feature at our factory. Provides a convenient, 15 amp, 115v GFCI receptacle with "Wet in Use" cover. The "powered" option allows the installer to power the outlet from the line side of the disconnect as required by code. The "unpowered" option is to be powered from a separate (non-unit) 115/120v power source. The unpowered convenience outlet is available as a 15 amp factory-installed option or a 20 amp field-installed accessory.

The 20 amp unpowered convenience outlet kit provides a flexible installation method which allows code compliance for height requirements of the GFCI outlet from the finished roof surface as well as the capability to relocate the outlet to a more convenient location, if necessary.

Non-Fused Disconnect

This OSHA-compliant, factory-installed, safety switch allows a service technician to locally secure power to the rooftop.

When selecting a factory-installed non-fused disconnect, note they are sized for unit as ordered from the factory.

The sizing of these does not accommodate any power exhaust devices, etc.

Power Exhaust with Barometric Relief

Superior internal building pressure control. This field-installed accessory or factory-installed option may eliminate the need for costly, external pressure control fans.

PremierLink™ DDC Controller

This CCN controller regulates your rooftop's performance to tighter tolerances and expanded limits, as well as facilitates zoning systems and digital accessories. It also unites your Carrier HVAC equipment together on one, coherent CCN network. The PremierLink controller can be factory-installed, or easily field-installed.

RTU Open Protocol Controller

Connect the rooftop to an existing BAS without needing complicated translators or adapter modules using the RTU Open controller. This new controller speaks the 4 most common building automation system languages (BACnet¹, Modbus², N2, and LonWorks³). Use this controller when you have an existing BAS.

Time Guard II Control Circuit

This accessory protects your compressor by preventing short-cycling in the event of some other failure, prevents the compressor from restarting for 30 seconds after stopping. Not required with PremierLink, RTU Open, or authorized commercial thermostats.

Filter or Fan Status Switches

Use these differential pressure switches to detect a filter clog or indoor fan motor failure. When used in conjunction with a compatible unit controller/thermostat, the switches will activate an alarm to warn the appropriate personnel.

Motorized 2-Position Damper

The new Carrier 2-position, motorized outdoor air damper admits up to 100% outside air. Using reliable, gear-driven technology, the 2-position damper opens to allow ventilation air and closes when the rooftop stops, stopping unwanted infiltration.

Manual OA Damper

Manual outdoor air dampers are an economical way to bring in ventilation air. The dampers are available in 25% versions.

Optional Humidi-MiZer® Adaptive Dehumidification System

Carrier's Humidi-MiZer adaptive dehumidification system is an all-inclusive factory-installed option that can be ordered with any WeatherMaster® 50HC17-28 rooftop unit.

This system expands the envelope of operation of Carrier's WeatherMaster rooftop products to provide unprecedented flexibility to meet year round comfort conditions.

The Humidi-MiZer adaptive dehumidification system has a unique dual operational mode setting. The Humidi-MiZer system includes two new modes of operation.

The WeatherMaster 50HC17-28 rooftop coupled with the Humidi-MiZer system is capable of operating in normal design cooling mode, subcooling mode, and hot gas reheat

1. BACnet is a registered trademark of ASHRAE (American Society of Heating, Refrigerating and Air-Conditioning Engineers).
2. Modbus is a registered trademark of Schneider Electric.
3. LonWorks is a registered trademark of Echelon Corporation.

mode. Normal design cooling mode is when the unit will operate under its normal sequence of operation by cycling compressors to maintain comfort conditions.

Subcooling mode will operate to satisfy part load type conditions when the space requires combined sensible and a higher proportion of latent load control. Hot Gas Reheat mode will operate when outdoor temperatures diminish and the need for latent capacity is required for sole humidity control. Hot Gas Reheat mode will provide neutral air for maximum dehumidification operation.

Staged Air Volume (SAV™) Indoor Fan Speed System

Carrier's Staged Air Volume (SAV) system saves energy and installation time by utilizing a Variable Frequency Drive (VFD) to automatically adjust the indoor fan motor speed in sequence with the units cooling operation. Per ASHRAE 90.1-2016 and IECC-2015 standards, during the first stage of cooling operation the VFD will adjust the fan motor to provide 66% of the total cfm established for the unit. When a call for the second stage of cooling is required, the VFD will allow the total cfm for the unit established (100%). During the heating mode the VFD will allow total design cfm (100%) operation and during the ventilation mode the VFD will allow operation to 66% of total cfm.

Compared to single speed indoor fan motor systems, Carrier's SAV system can save substantial energy, 25%+, versus single speed indoor fan motor systems.

IMPORTANT: Data based on 0.10 (\$/kWh) in an office application utilizing Carrier's HAP 4.6 simulation software program.

The VFD used in Carrier's SAV system has soft start capabilities to slowly ramp up the speeds, thus eliminating any high inrush air volume during initial start-up. It also has internal over current protection for the fan motor and a field-installed display kit that allows adjustment and in depth diagnostics of the VFD.

This SAV system is available on models with 2-stage cooling operation with electrical mechanical or RTU Open (multi Protocol) controls. Both space sensor and conventional thermostats controls can be used to provide accurate control in any application.

The SAV system is very flexible for initial fan performance set up and adjustment. The standard factory-shipped VFD is pre-programmed to automatically stage the fan speed between the first and second stage of cooling. The unit fan performance static pressure and cfm can be easily adjusted using the traditional means of pulley adjustments. The other means to adjust the unit static and cfm performance is to utilize the field-installed display kit and adjust the frequency and voltage in the VFD to required performance requirements. In either case, once set up, the VFD will automatically adjust the speed between the cooling stage operations.

Motormaster® Head Pressure Controller

The Motormaster motor controller is a low ambient, head pressure controller kit that is designed to maintain the unit's condenser head pressure during periods of low ambient cooling operation. This device should be used as an alternative to economizer free cooling when economizer usage is either not appropriate or desired. The Motormaster will either cycle the outdoor-fan motors or operate them at reduced speed to maintain the unit operation,

depending on the model. Motormaster allows cooling operation down to -20°F (-29°C) ambient conditions.

Winter Start Kit

The winter start kit by Carrier extends the low ambient limit of your rooftop to 25°F (-4°C). The kit bypasses the low pressure switch, preventing nuisance tripping of the low pressure switch. Other low ambient precautions may still be prudent.

Alternate Motors and Drives

Some applications need larger horsepower motors, some need more airflow, and some need both. Regardless of the case, your Carrier expert has a factory-installed combination to meet your application. A wide selection of motors and pulleys (drives) are available, factory-installed, to handle nearly any application.

Thru-the-Base Connections

Thru-the-base provisions/connection points are available as standard with every unit. When bottom connections are required, field furnished couplings are required.

Electric Heaters / Single Point Kit

Carrier offers a full-line of factory and field-installed heaters and single point kits when required. The heaters are very easy to use, install and are all pre-engineered and certified.

Barometric Hood

For horizontal economizer applications where relief damper is installed in duct work. This kit provides the needed protection.

Hinged Access Panels

Allows access to unit's major components with specifically designed hinged access panels. Panels are filter, control box, indoor fan motor.

ComfortLink Controls

Models with the optional Carrier *ComfortLink* controls allow added unit diagnostics and operation setup capabilities, as well as controlling logic for single zone variable air volume (VAV) applications. *ComfortLink* comes standard with units equipped with EnergyX.

The *ComfortLink* control is your link to a world of simple and easy to use rooftop units that offer outstanding performance and value. It optimizes the performance of the refrigeration circuits as conditions change, resulting in the following features:

- Better control of temperature and humidity
- Superior reliability
- Automatic redundancy
- Low ambient cooling operation to 0°F (-18°C)
- More accurate diagnostics, at unit or remote

The *ComfortLink* Scrolling Marquee is very easy to use. The messages are displayed in easy to understand English, no decoding is required. A scrolling readout provides detailed explanations of control information. Only four, large, easy-to-use buttons are required to maneuver through the entire menu. The readout is designed to be visible even in the brightest sunlight. A handheld Navigator™ accessory or wall-mounted System Pilot™ accessory can be used for added service flexibility.

The *ComfortLink* control provides service diagnostic information. Temperature and pressure can be read directly from the display with no need for separate gages. Other data, such as compressor cycles, unit run time hours, and

current alarms, can also be accessed. A history of alarms is also available for viewing.

The service run test can be very helpful when troubleshooting. The user can run test major components to determine the root cause of a problem. The unit can be run-tested before an installation is complete to ensure satisfactory start-up. To ensure reliability, the *ComfortLink* control prevents reverse compressor rotation. No laptop computers are required for start-up.

Time schedules are built in and the Scrolling Marquee display provides easy access to setpoints. The *ComfortLink* control accepts input from a CO₂ sensor and a smoke detector. Both are available as factory-installed options or as field-installed accessories.

HACR Breaker

These manual reset devices provide overload and short circuit protection for the unit. Factory wired and mounted with the units with access cover to help provide environment protection.

On 575V applications, HACR breaker can only be used with WYE power distribution systems. Use on Delta power distribution systems is prohibited.

Foil Faced Insulated Cabinet

Cabinet is fully insulated with non-fibrous, foil faced cleanable insulation that is secured and encapsulated in unit design.

Low Ambient Controller

The low ambient controller is a head pressure controller kit that is designed to maintain the unit's condenser head pressure during periods of low ambient cooling operation. This device should be used as an alternative to economizer free cooling not when economizer usage is either not appropriate or desired. The low ambient controller will either cycle the outdoor fan motors or operate them at reduced speed to maintain the unit operation, depending on the model. This controller allows cooling operation down to 0°F (-18°C) ambient conditions.

Condensate Overflow Switch

This sensor and related controller monitors the condensate level in the drain pan and shuts down compression operation when overflow conditions occur. It includes:

- Indicator light - solid red (more than 10 seconds on water contact - compressors disabled), blinking red (sensor disconnected).
- 10 second delay to break - eliminates nuisance trips from splashing or waves in pan (sensor needs 10 seconds of constant water contact before tripping).
- Disables the compressor(s) operation when condensate plug is detected, but still allows fans to run for economizer.

EnergyX® Energy Recovery Ventilator (ERV)

EnergyX System is a factory installed Energy Recovery Ventilator (ERV) module on a Carrier packaged rooftop unit. It is integrated with the base rooftop unit structurally, electrically and with regard to controls operation.

EnergyX with economizer (3-phase models only)

Allows true modulating economizer capability when OA is suitable for free cooling.

- operates as a true wheel bypass
- uses stop/jog operation for wheel required when using CO₂ sensor for DCV operation
- economizer integrated into EnergyX unit

EnergyX with frost protection (3-phase models only)

Senses pressure differential across the energy recovery cassette. Uses exhaust air to defrost the wheel when necessary.

California OSHPD Seismic Certification Label

Units meet the seismic requirements of the International Code Council Evaluation Service (ICC-ES) document AC156 (Acceptance Criteria for Seismic Qualification by Shake-Table Testing of Nonstructural Components and Systems) and per International Building Code (IBC 2009) at an SDS (g) value of 2.00 z/h=1.0, Ip=1.5 and certified by independent structural engineers. A certification label is applied to the unit that meets the CA OSHPD Special Seismic Certification pre-approval labeling requirements on the external chassis of the unit.

OSHPD not available on units with factory installed Humidi-MiZer, HACR breaker, MCHX coils, low ambient controls, hailguards, or EnergyX system.



OPTIONS AND ACCESSORY WEIGHT ADDERS

BASE UNIT WITH OPTIONS AND ACCESSORIES (Weight Adders)	MAX WEIGHT ADD							
	50HC**17		50HC**20		50HC**24		50HC**28	
	lb	kg	lb	kg	lb	kg	lb	kg
Base Unit Operating Weight	1793	813	2003	909	2148	974	2193	975
EnergyX® System	1438	652	1438	652	1648	747	1648	747
Humidi-MiZer® System*	110	50	120	55	120	55	120	55
Power Exhaust	125	57	125	57	125	57	125	57
EconoMiSer® (IV, X, or 2)	170	77	170	77	170	77	195	88
Copper Tube/Fin Evaporator Coil	110	50	110	50	135	61	161	73
Electric Heater	85	39	85	39	85	39	85	39
Single Point Electrical Kit	15	7	15	7	15	7	15	7
Roof Curb 14-in. (356 mm)	240	109	240	109	240	109	255	116
Roof Curb 24-in. (610 mm)	340	154	340	154	340	154	355	161
Louvered Hail Guard	60	27	60	27	120	54	150	68
CO ₂ Sensor	5	2	5	2	5	2	5	2
Return Smoke Detector	5	2	5	2	5	2	5	2
Supply Smoke Detector	5	2	5	2	5	2	5	2
Fan/Filter Status Switch	2	1	2	1	2	1	2	1
Non-Fused Disconnect	15	7	15	7	15	7	15	7
HACR Circuit Breaker	15	7	15	7	15	7	15	7
Powered Convenience Outlet	35	16	35	16	35	16	35	16
Non-Powered Convenience Outlet	5	2	5	2	5	2	5	2
Enthalpy Sensor	2	1	2	1	2	1	2	1
Differential Enthalpy Sensor	3	1	3	1	3	1	3	1
Two Position Motorized Damper	50	23	50	23	50	23	65	29
Manual Damper	35	16	35	16	35	16	40	18
Field Filter Track 4-in. (102 mm)	12	5	12	5	12	5	12	5
Motormaster® Controller	35	16	35	16	35	16	35	16
Medium Static Motor/Drive	5	2	6	3	6	3	6	3
High Static Motor/Drive	11	5	12	5	16	7	16	7
Barometric Relief Hood (Horizontal)	25	11	25	11	25	11	25	11
SAV™ System with VFD	20	9	20	9	20	9	20	9

* For Humidi-MiZer system add Motormaster controller.

NOTE: Where multiple variations are available, the heaviest combination is listed.

UNIT DIMENSIONAL DRAWING — 50HC*17 VERTICAL AIRFLOW

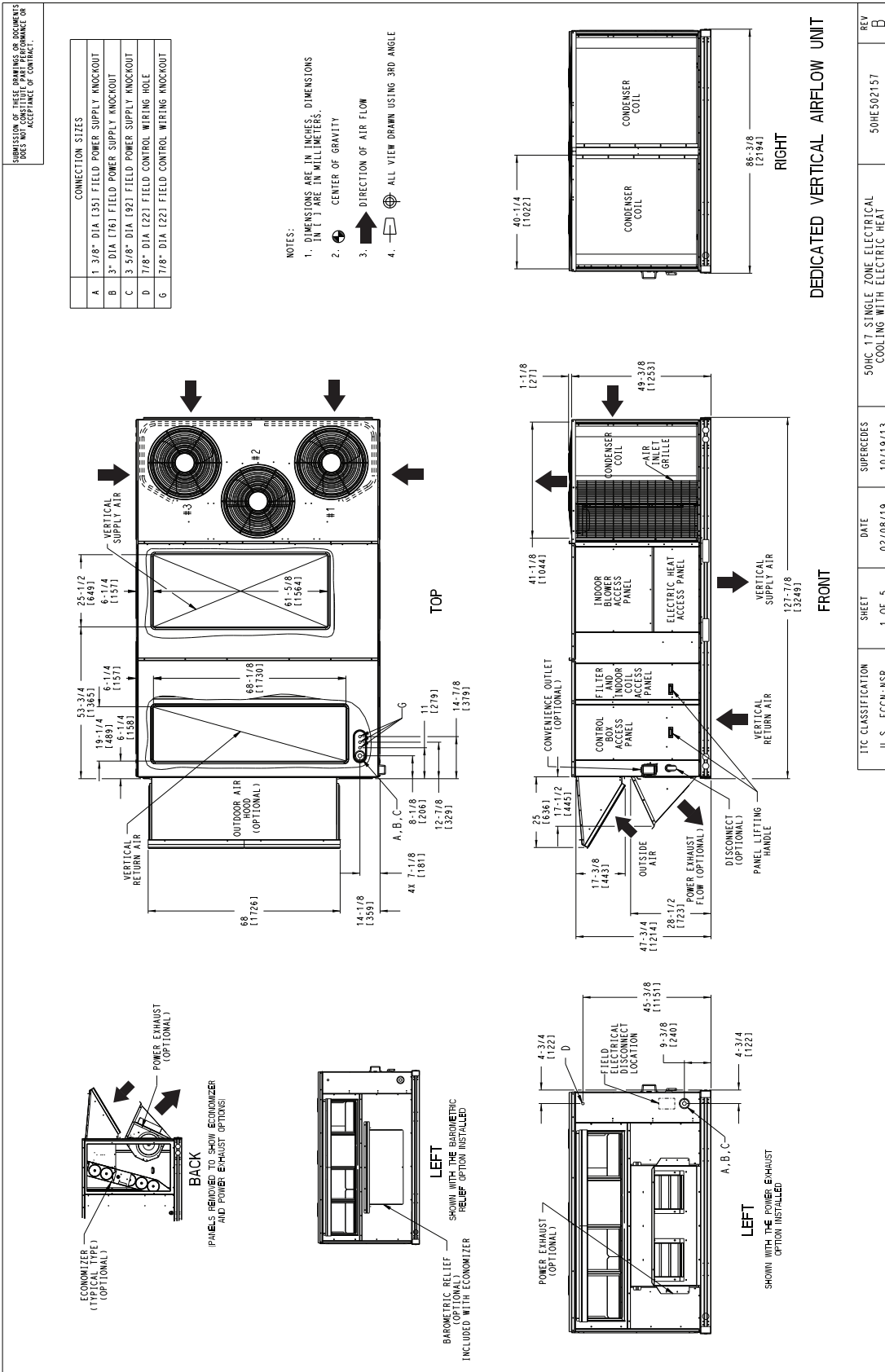

TIC CLASSIFICATION	SHEET	DATE	SUPERCEDES	50HC 17 SINGLE ZONE ELECTRICAL COOLING WITH ELECTRIC HEAT	REV
U.S. ECCN: NSR	1 OF 5	02/08/19	10/19/13		B

UNIT DIMENSIONAL DRAWING — 50HC**17 HORIZONTAL AIRFLOW

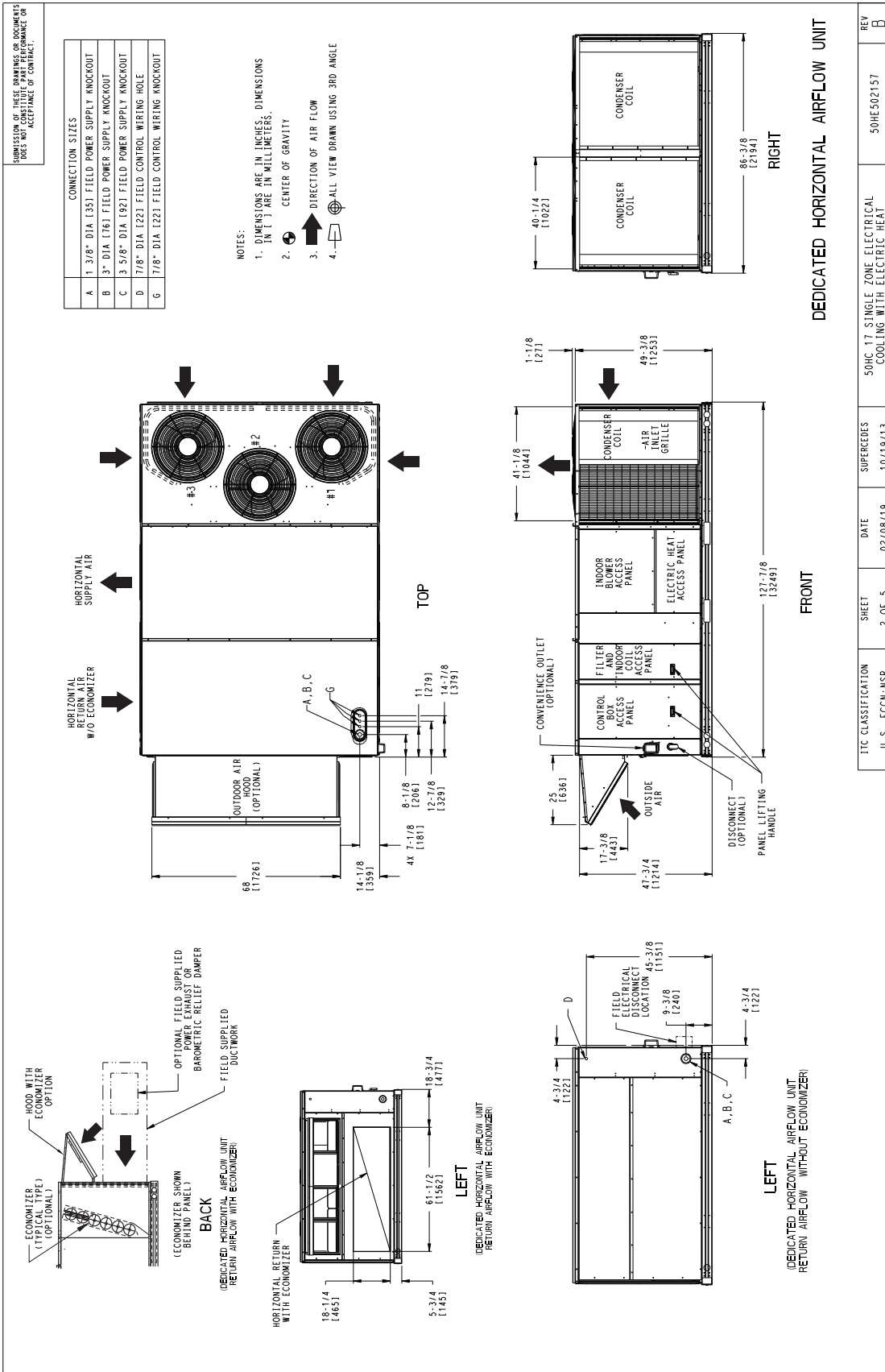

UNIT DIMENSIONAL DRAWING — 50HC**17 BACK VIEW AND CONDENSATE DRAIN LOCATION

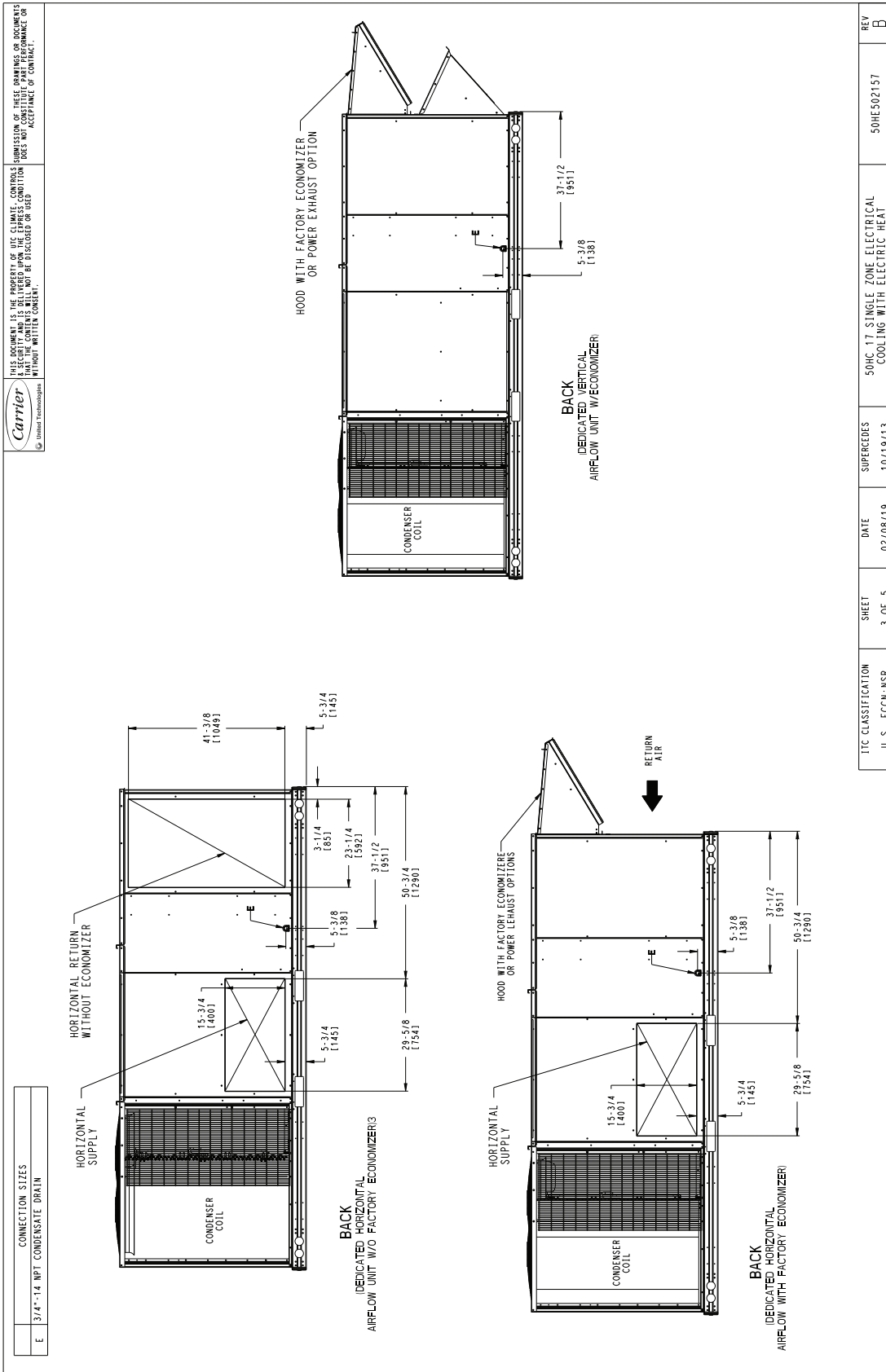

UNIT DIMENSIONAL DRAWING — 50HC**17 CORNER WEIGHTS AND CLEARANCES

SUBMISSION OF THESE DRAWINGS OR DOCUMENTS DOES NOT CONSTITUTE PART PERFORMANCE OR ACCEPTANCE OF CONTRACT.

UNIT	STD UNIT WEIGHT		CORNER WEIGHT (A)		CORNER WEIGHT (B)		CORNER WEIGHT (C)		CORNER WEIGHT (D)		C.G.					
	LBS.	KG.	LBS.	KG.	LBS.	KG.	LBS.	KG.	LBS.	KG.	X	Y	Z			
50HC17	1793	815	375	170	419	191	528	240	472	214	48	1219	67	3/8 [17113]	16	1/2 [419]

* STANDARD UNIT WEIGHT IS WITHOUT ELECTRIC HEAT AND WITHOUT PACKAGING. FOR OTHER OPTIONS AND ACCESSORIES, REFER TO THE PRODUCT DATA CATALOG.

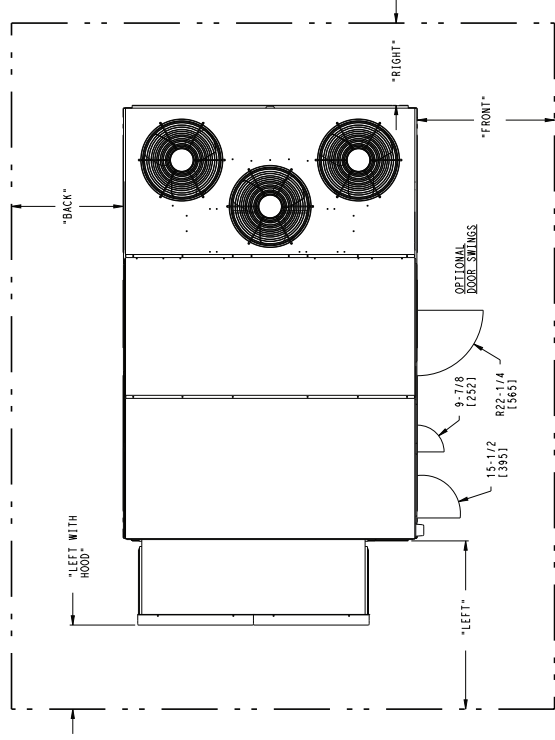

- NOTES:
- CLEARANCE ABOVE THE UNIT TO BE 72"
 - FOR ALL MINIMUM CLEARANCES LOCAL CODES OR JURISDICTIONS MAY PREVAIL.

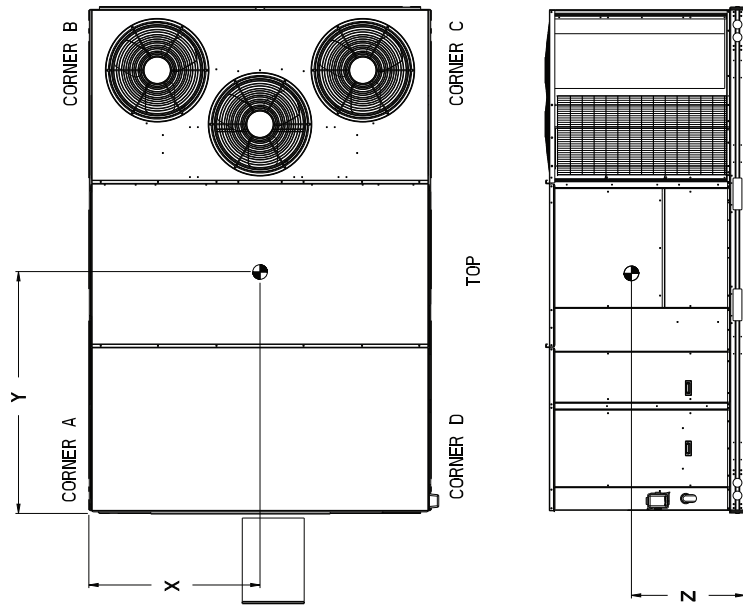

SURFACE	CLEARANCE		OPERATING CLEARANCE	
	SERVICE WITH CONDUCTIVE BARRIER	SERVICE WITH NONCONDUCTIVE BARRIER	SERVICE WITH CONDUCTIVE BARRIER	SERVICE WITH NONCONDUCTIVE BARRIER
FRONT	48 [1219mm]	36 [914mm]	18 [457mm]	18 [457mm]
LEFT	48 [1219mm]	42 [1067mm]	18 [457mm]	18 [457mm]
BACK	42 [1067mm]	36 [914mm]	18 [457mm]	18 [457mm]
LEFT WITH HOOD	36 [914mm]	36 [914mm]	18 [457mm]	18 [457mm]
RIGHT	36 [914mm]	36 [914mm]	18 [457mm]	18 [457mm]
TOP	72 [1829mm]	72 [1829mm]	72 [1829mm]	72 [1829mm]

TIC CLASSIFICATION	SHEET	DATE	SUPERCEDES	REV
U.S. - ECCN: NSR	4 OF 5	02/08/19	50HC 17 SINGLE ZONE ELECTRICAL COOLING WITH ELECTRIC HEAT	B

Base unit dimensions (cont)



UNIT DIMENSIONAL DRAWING — 50HC*17 BOTTOM VIEW

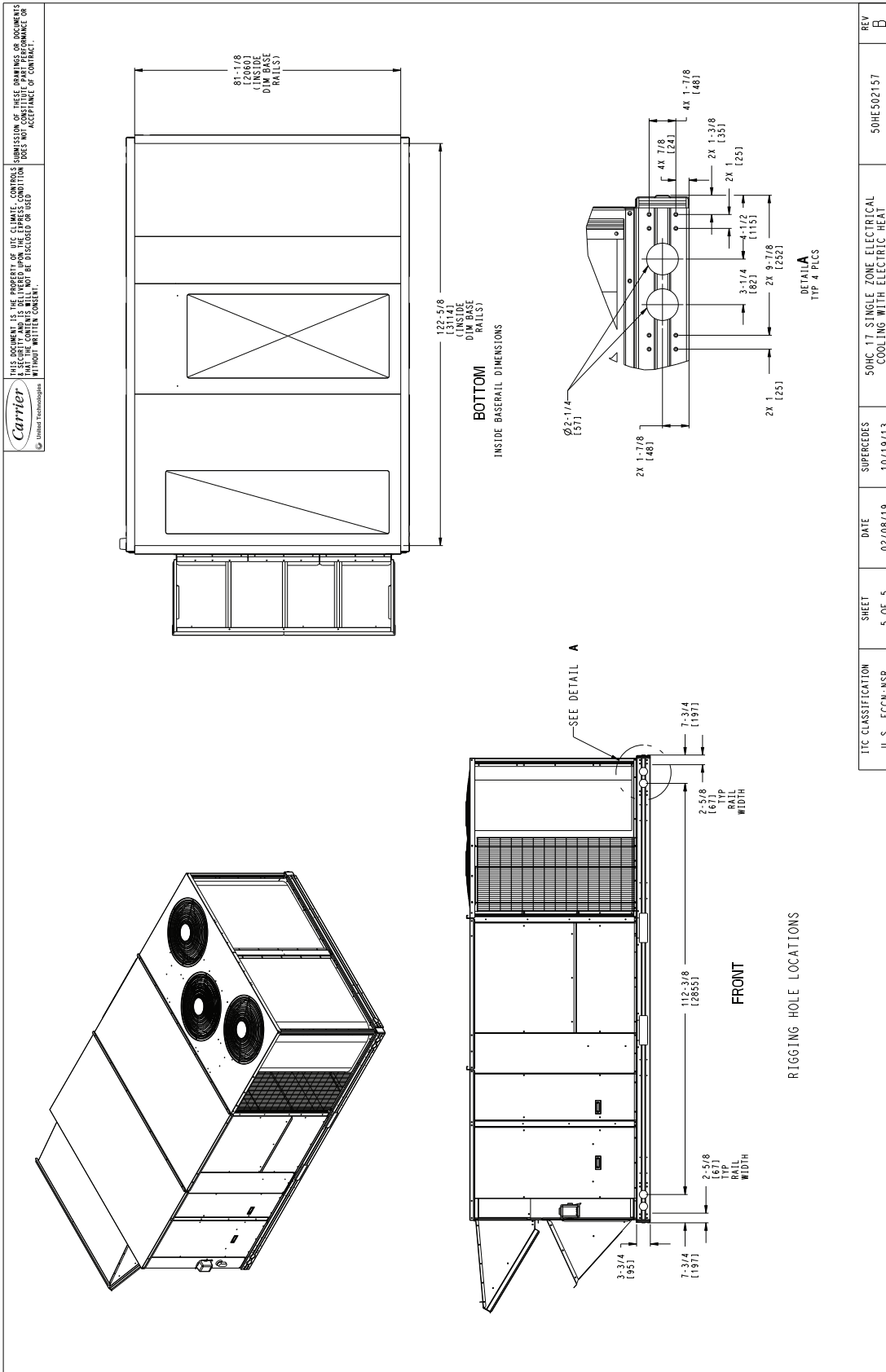

ITC CLASSIFICATION	SHEET	DATE	SUPERSEDES	50HC 17 SINGLE ZONE ELECTRICAL COOLING WITH ELECTRIC HEAT	REV
U.S. - ECCN: NSR	5 OF 5	02/08/19	10/19/13		B
				50HS502157	

UNIT DIMENSIONAL DRAWING — 50HC**20-24 VERTICAL AIRFLOW

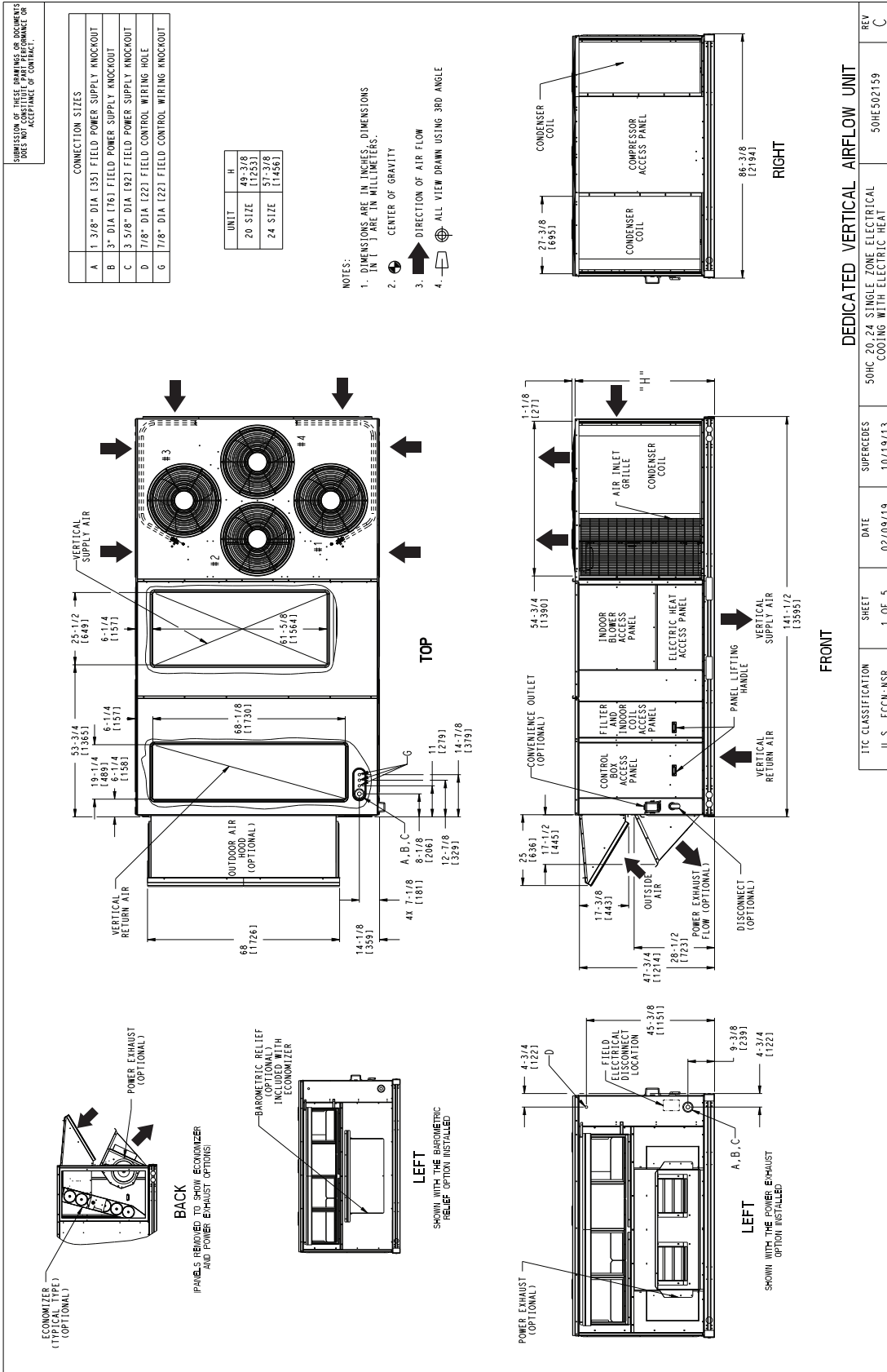

UNIT DIMENSIONAL DRAWING — 50HC**20-24 HORIZONTAL AIRFLOW

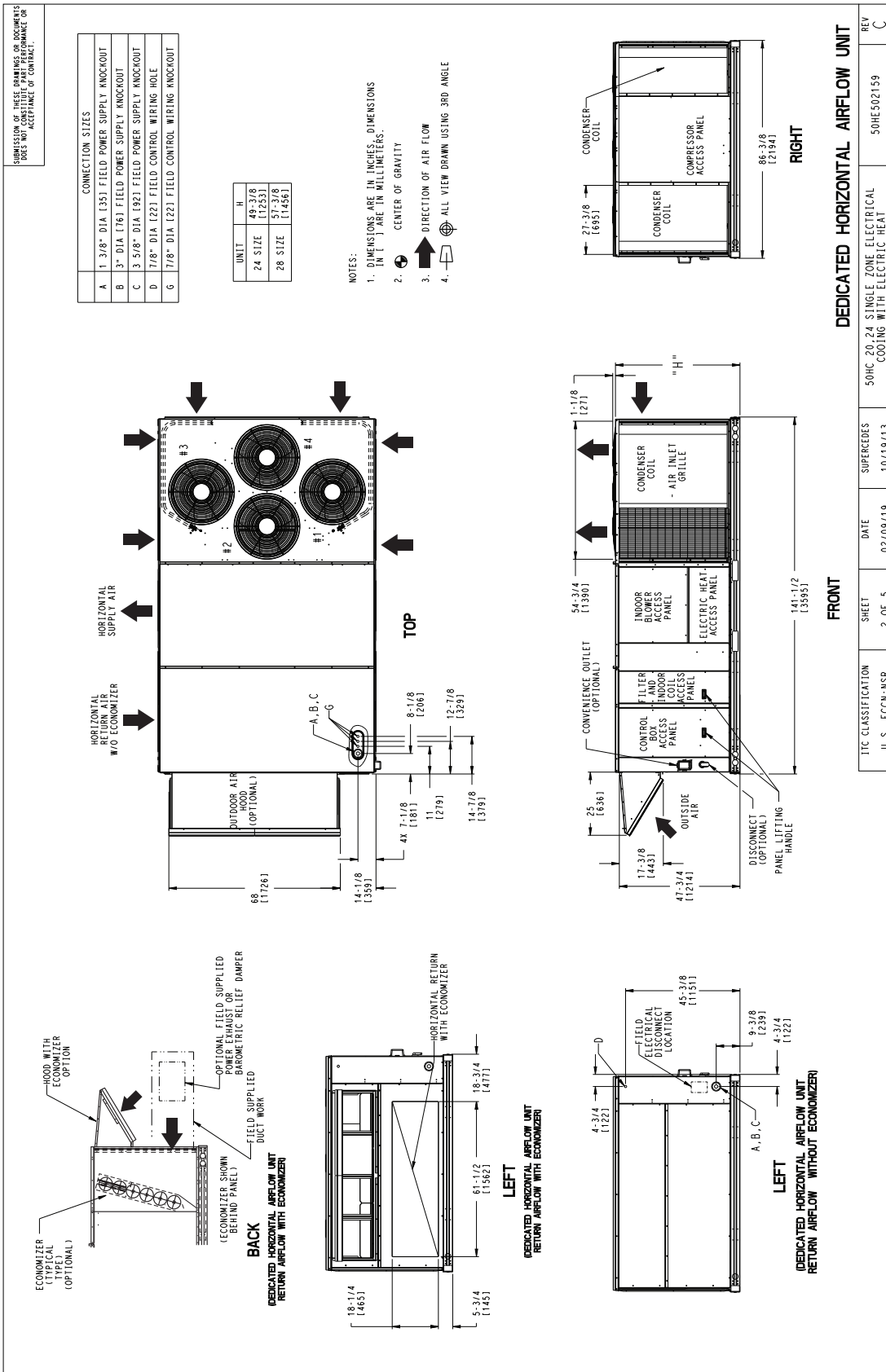

UNIT DIMENSIONAL DRAWING — 50HC**20-24 BACK VIEW AND CONDENSATE DRAIN

THIS DOCUMENT IS THE PROPERTY OF HVAC CLIMATE CONTROLS. SUBMISSION OF THESE DRAWINGS OR DOCUMENTS TO ANY OTHER PARTY WITHOUT THE WRITTEN CONSENT OF HVAC CLIMATE CONTROLS IS PROHIBITED. THE USER AGREES TO HOLD HVAC CLIMATE CONTROLS HARMLESS FROM AND TO INDEMNIFY HVAC CLIMATE CONTROLS FROM AND AGAINST ALL CLAIMS, DAMAGES, LOSSES AND EXPENSES, INCLUDING REASONABLE ATTORNEY'S FEES, THAT MAY BE ASSERTED AGAINST OR INCURRED BY HVAC CLIMATE CONTROLS AS A RESULT OF THE USER'S USE OF THIS DOCUMENT WITHOUT WRITTEN CONSENT.



UNIT	G
24 SIZE	41-3/8 (1049)
28 SIZE	49-1/4 (1251)

CONNECTION SIZES	
E	3/4" - 1/4 NPT CONDENSATE DRAIN

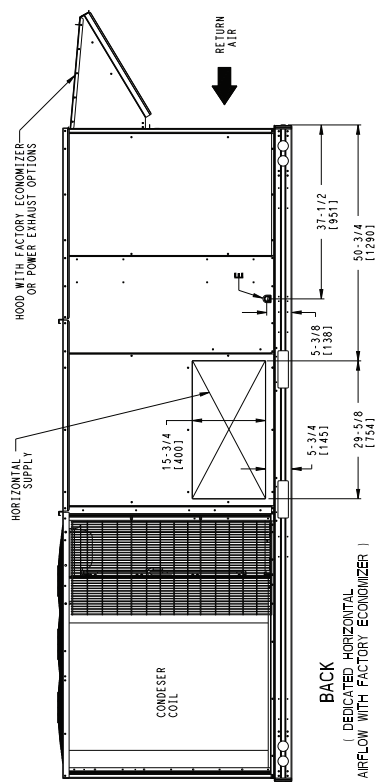
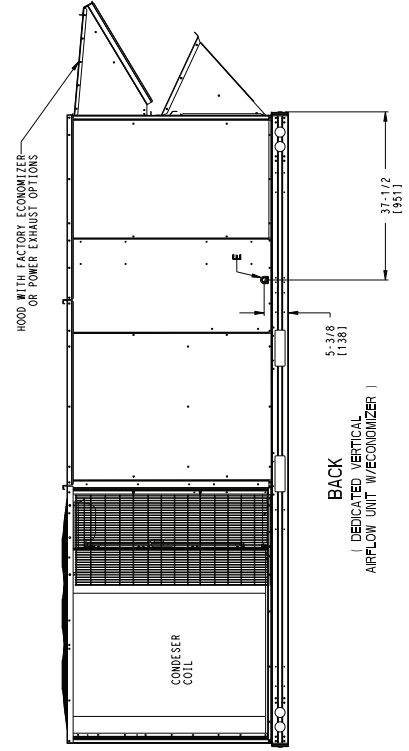
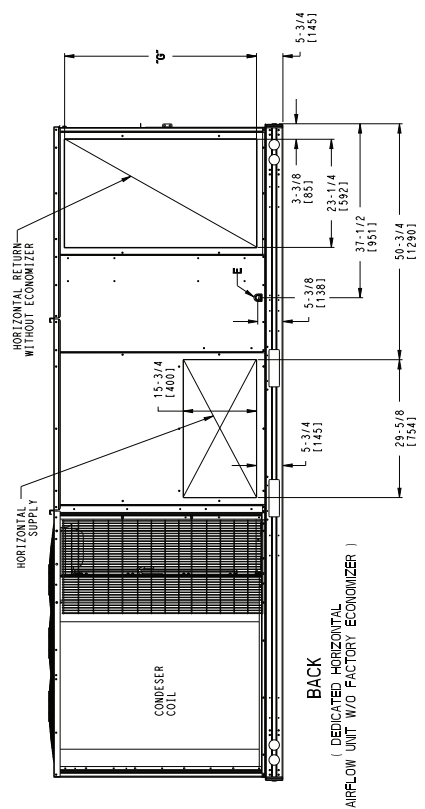

TIC CLASSIFICATION	SHEET	DATE	SUPERCEDES	REV
U.S. ECCN: NSR	3 OF 5	02/09/19	10/19/13	C
			50HE502159	
			50HC 20,24 SINGLE ZONE ELECTRICAL COOLING WITH ELECTRIC HEAT	

UNIT DIMENSIONAL DRAWING — 50HC**20-24 CORNER WEIGHTS AND CLEARANCES

SUBMISSION OF THESE DIMENSIONS OR DOCUMENTS DOES NOT CONSTITUTE AN ACCEPTANCE OF CONTRACT.

UNIT	CORNER WEIGHT (A)		CORNER WEIGHT (B)		CORNER WEIGHT (C)		CORNER WEIGHT (D)		C.G.								
	LBS.	KG.	LBS.	KG.	LBS.	KG.	LBS.	KG.	X	Y	Z						
50HC20	2003	911	445	202	367	167	557	253	547	249	112	117	114	1810	16	1/2	419
50HC24	2148	976	510	232	525	238	564	257	549	250	114	113	111	1819	19	1/2	483

* STANDARD UNIT WEIGHT IS WITHOUT ELECTRIC HEAT AND WITHOUT PACKAGING.
FOR OTHER OPTIONS AND ACCESSORIES, REFER TO THE PRODUCT DATA CATALOG.

NOTES:
1. CLEARANCE ABOVE THE UNIT TO BE 72"
2. FOR ALL MINIMUM CLEARANCES LOCAL CODES OR JURISDICTIONS MAY PREVAIL.

SURFACE	SERVICE WITH CONDUCTIVE BARRIER CLEARANCE		SERVICE WITH NONCONDUCTIVE BARRIER CLEARANCE		OPERATING CLEARANCE	
	FRONT	LEFT	BACK	RIGHT	TOP	FRONT
FRONT	48 [1219mm]	48 [1219mm]	42 [1067mm]	42 [1067mm]	36 [914mm]	18 [457mm]
LEFT	48 [1219mm]	42 [1067mm]	36 [914mm]	36 [914mm]	36 [914mm]	18 [457mm]
BACK	42 [1067mm]	36 [914mm]	36 [914mm]	36 [914mm]	36 [914mm]	18 [457mm]
RIGHT	42 [1067mm]	36 [914mm]	36 [914mm]	36 [914mm]	36 [914mm]	18 [457mm]
TOP	72 [1829mm]	72 [1829mm]	72 [1829mm]	72 [1829mm]	72 [1829mm]	72 [1829mm]

UNIT DIMENSIONAL DRAWING — 50HC**20-24 BOTTOM VIEW

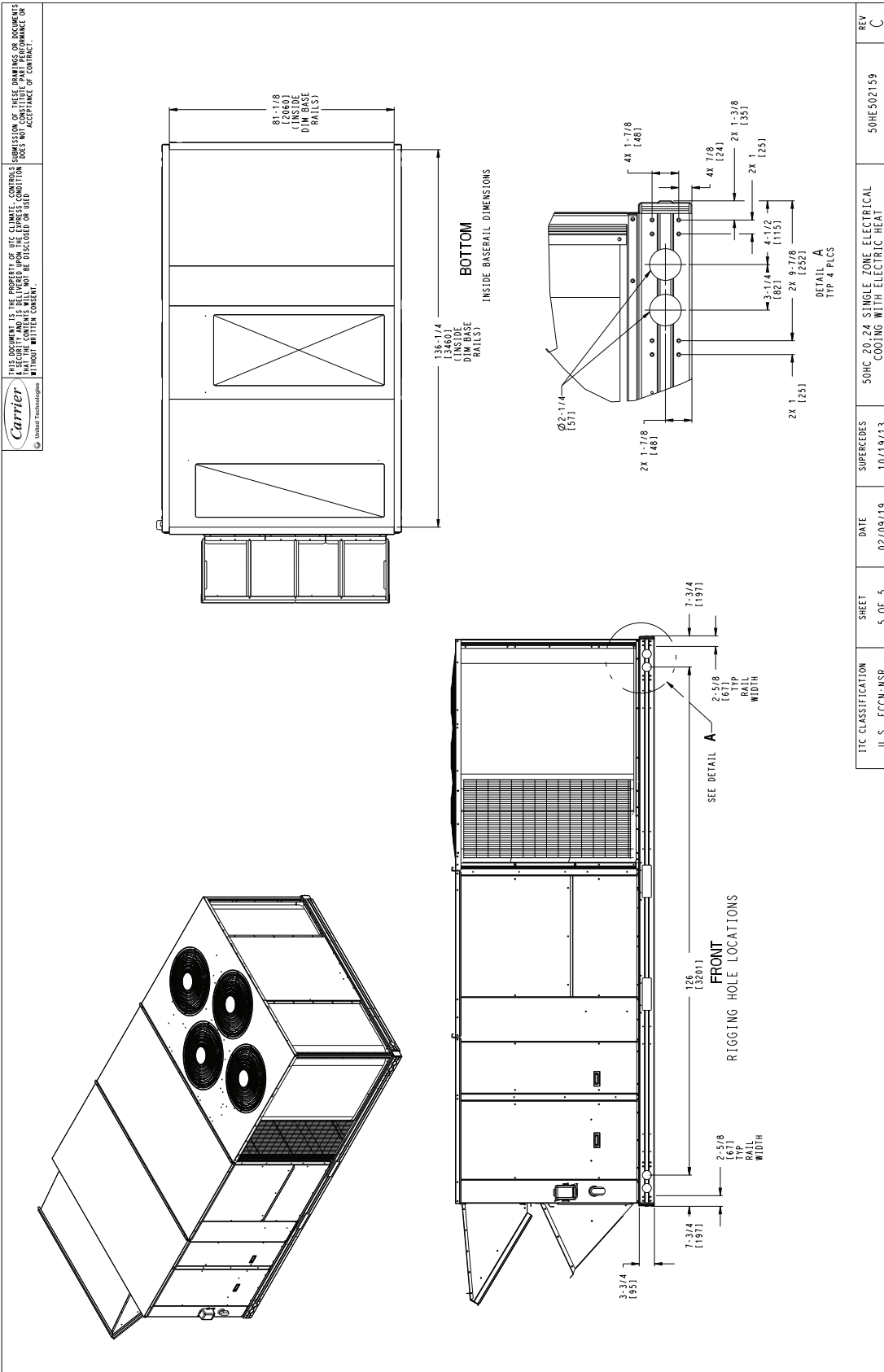

UNIT DIMENSIONAL DRAWING — 50HC*28 VERTICAL AIRFLOW

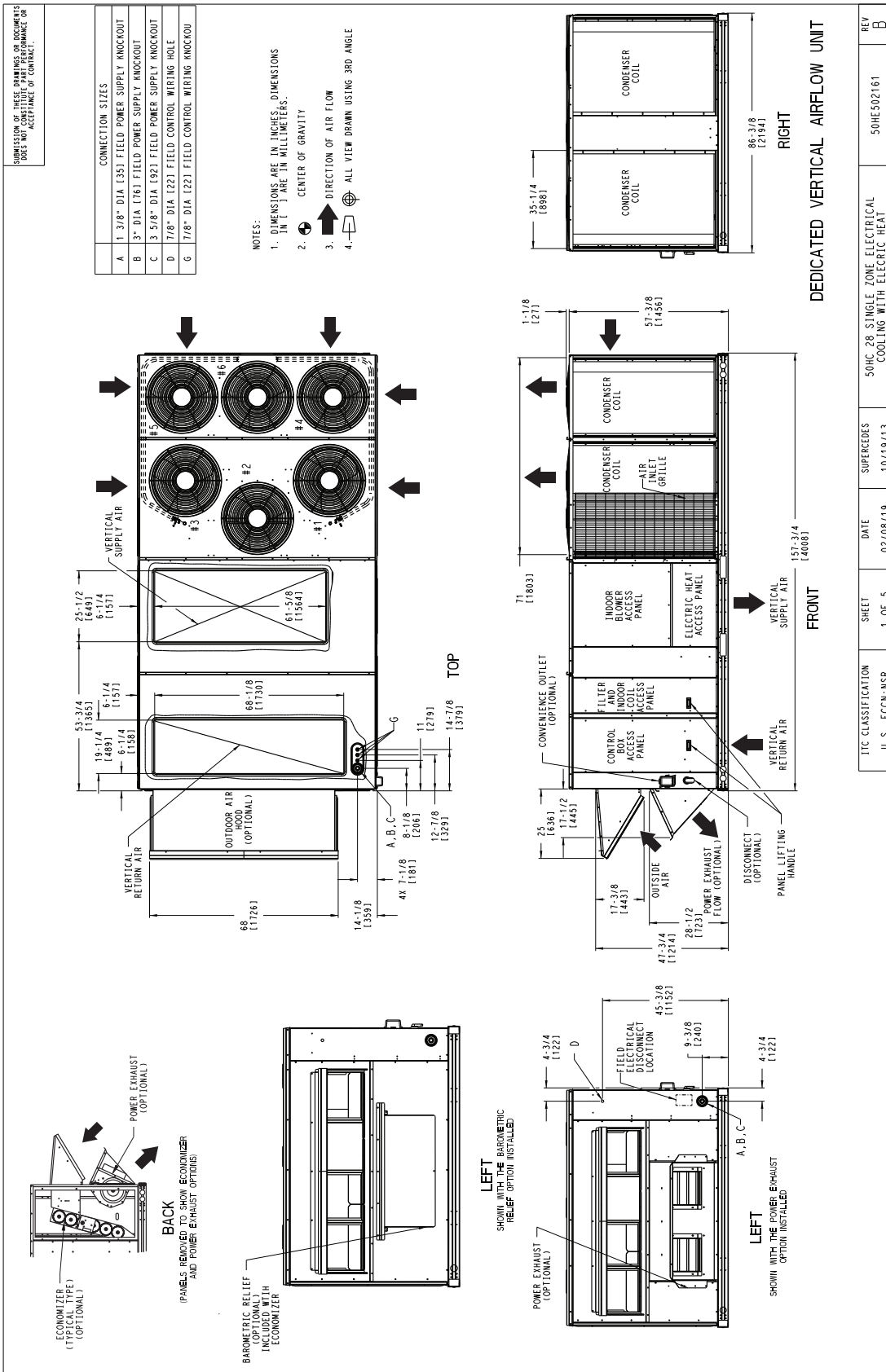

UNIT DIMENSIONAL DRAWING — 50HC**28 HORIZONTAL AIRFLOW

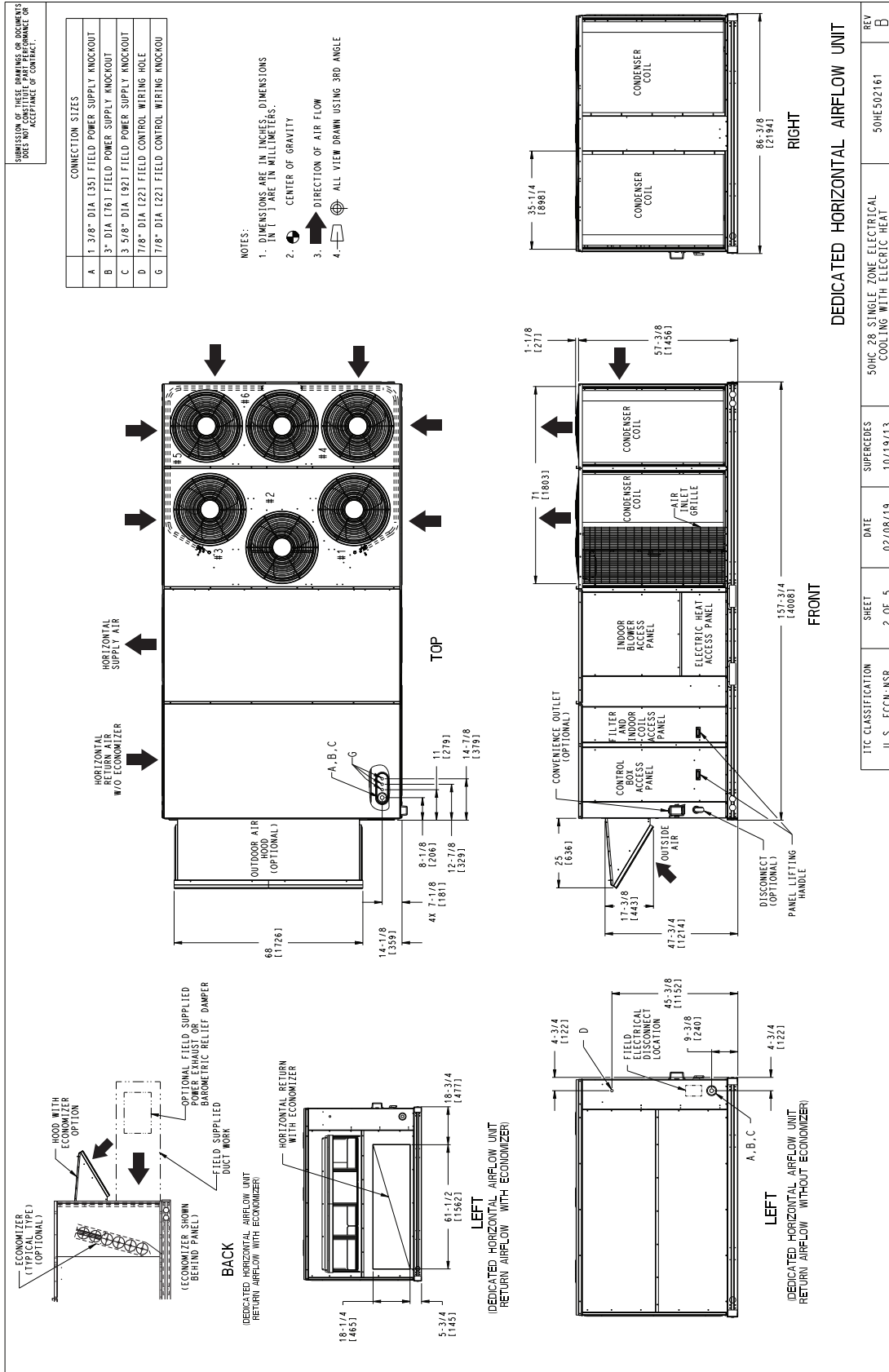

UNIT DIMENSIONAL DRAWING — 50HC**28 BACK VIEW AND CONDENSATE DRAIN LOCATION

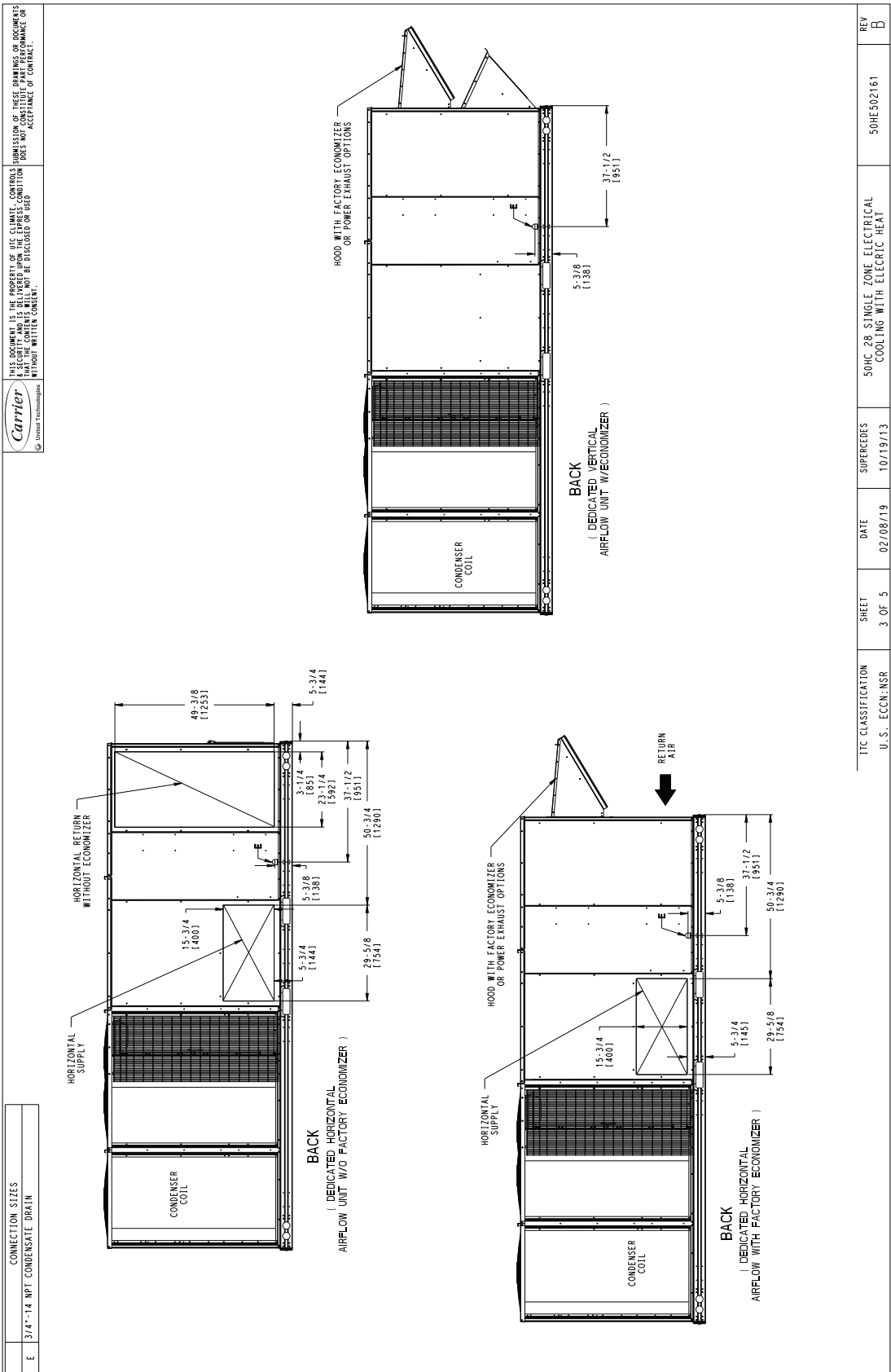

UNIT DIMENSIONAL DRAWING — 50HC**28 CORNER WEIGHTS AND CLEARANCE

SUBMISSION OF THESE DIMENSIONS OR DOCUMENTS DOES NOT CONSTITUTE AN ACCEPTANCE OF CONTRACT.

UNIT	STD UNIT WEIGHT *		CORNER WEIGHT (A)		CORNER WEIGHT (B)		CORNER WEIGHT (C)		CORNER WEIGHT (D)		C. G.							
	LBS.	KG.	LBS.	KG.	LBS.	KG.	LBS.	KG.	LBS.	KG.	X	Y	Z					
50HC28	2193	997	545	248	528	240	551	251	589	259	44	1118	177	172	1196	53	19	483

* STANDARD UNIT WEIGHT IS WITHOUT ELECTRIC HEAT AND WITHOUT PACKAGING. FOR OTHER OPTIONS AND ACCESSORIES, REFER TO THE PRODUCT DATA CATALOG.

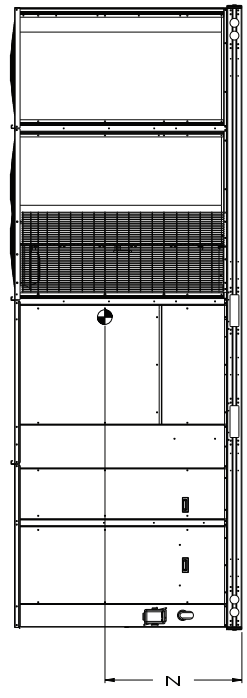
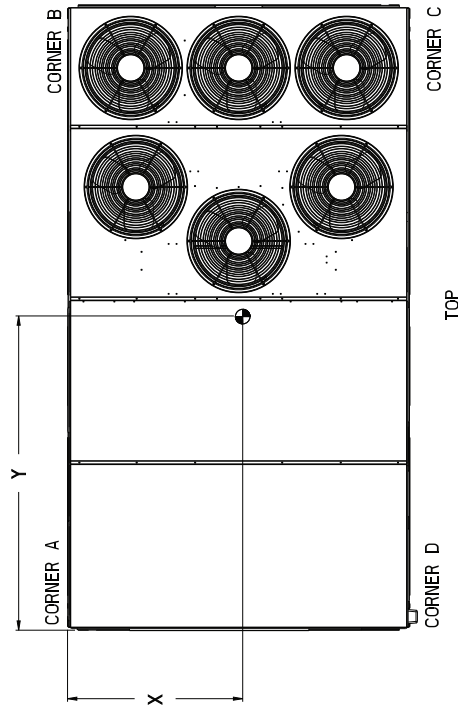
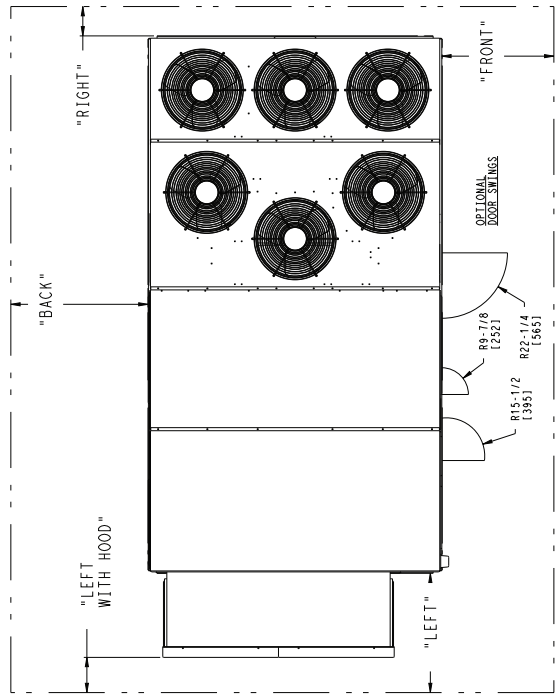

- NOTES:
- CLEARANCE ABOVE THE UNIT TO BE 72"
 - FOR ALL MINIMUM CLEARANCES LOCAL CODES OR JURISDICTIONS MAY PREVAIL.

SURFACE	CLEARANCE		OPERATING CLEARANCE
	SERVICE WITH CONDUCTIVE BARRIER	SERVICE WITH NONCONDUCTIVE BARRIER	
FRONT	48 [1219mm]	36 [914mm]	18 [457mm]
LEFT	42 [1067mm]	36 [914mm]	18 [457mm]
BACK	42 [1067mm]	36 [914mm]	18 [457mm]
RIGHT	36 [914mm]	36 [914mm]	18 [457mm]
TOP	72 [1829mm]	72 [1829mm]	72 [1829mm]

ITC CLASSIFICATION	SHEET	DATE	REV
U.S. - ECCN: NSR	4 OF 5	02/08/19	B
SUPERCEDES		50HC 28 SINGLE ZONE ELECTRICAL COOLING WITH ELECTRIC HEAT	50HE502161

UNIT DIMENSIONAL DRAWING — 50HC**28 BOTTOM VIEW

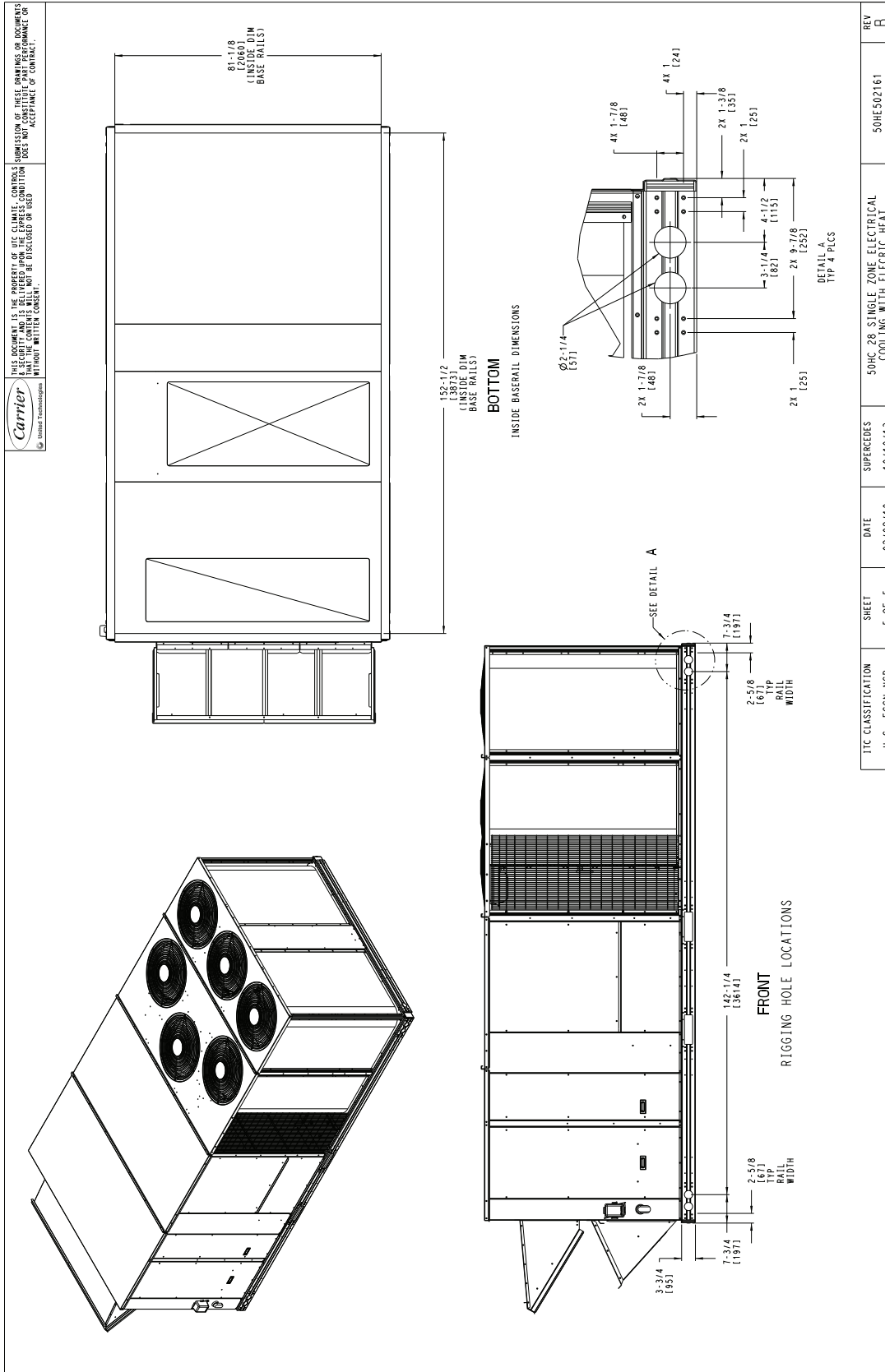

UNIT DIMENSIONAL DRAWING — 50HC**17 UNITS WITH ENERGYX SYSTEM

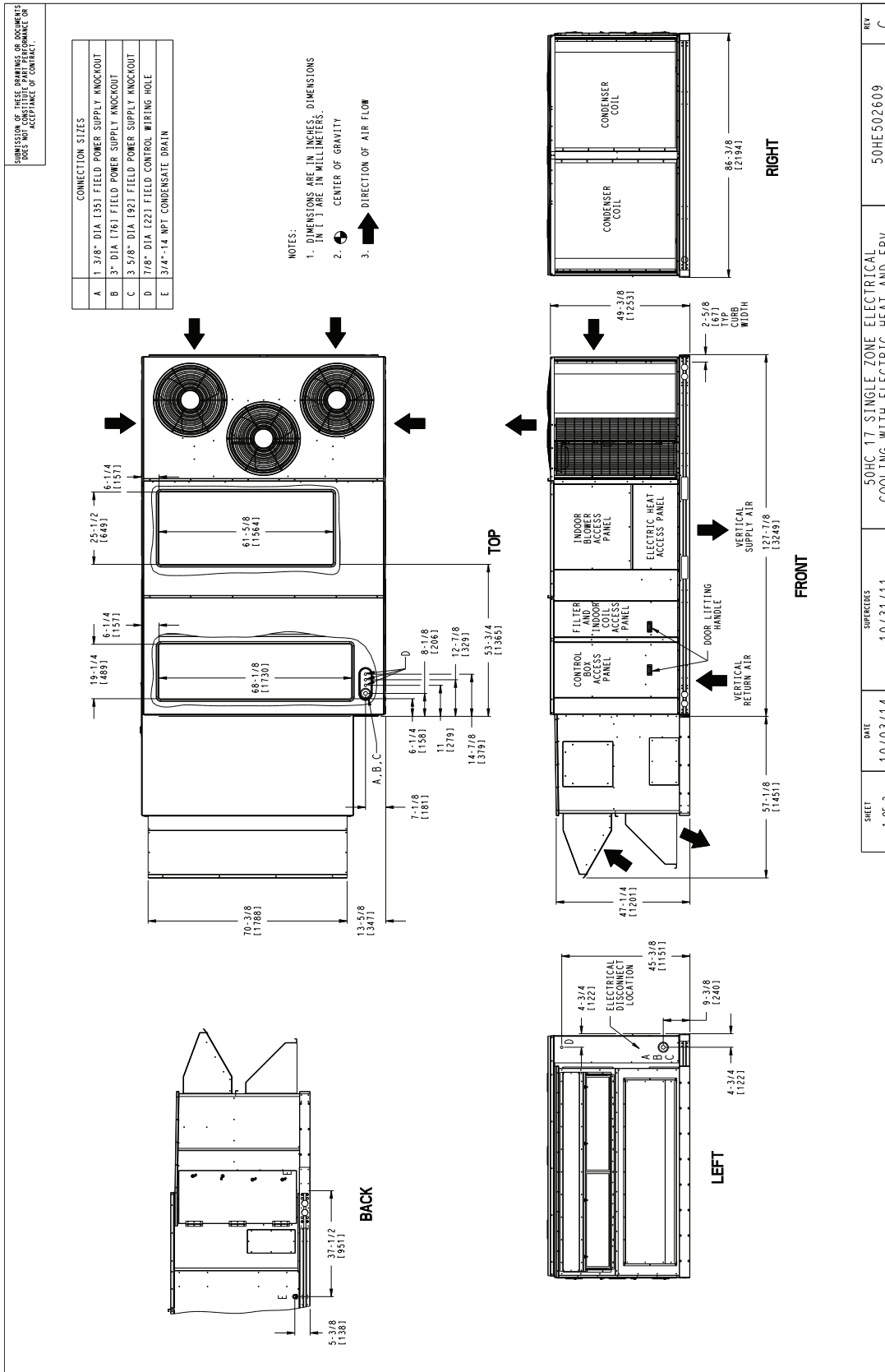

UNIT DIMENSIONAL DRAWING — 50HC**17 UNITS WITH ENERGYX SYSTEM (cont)

SUBMISSION OF THESE DRAWINGS OR DOCUMENTS DOES NOT CONSTITUTE PART PERFORMANCE OR ACCEPTANCE OF CONTRACT.

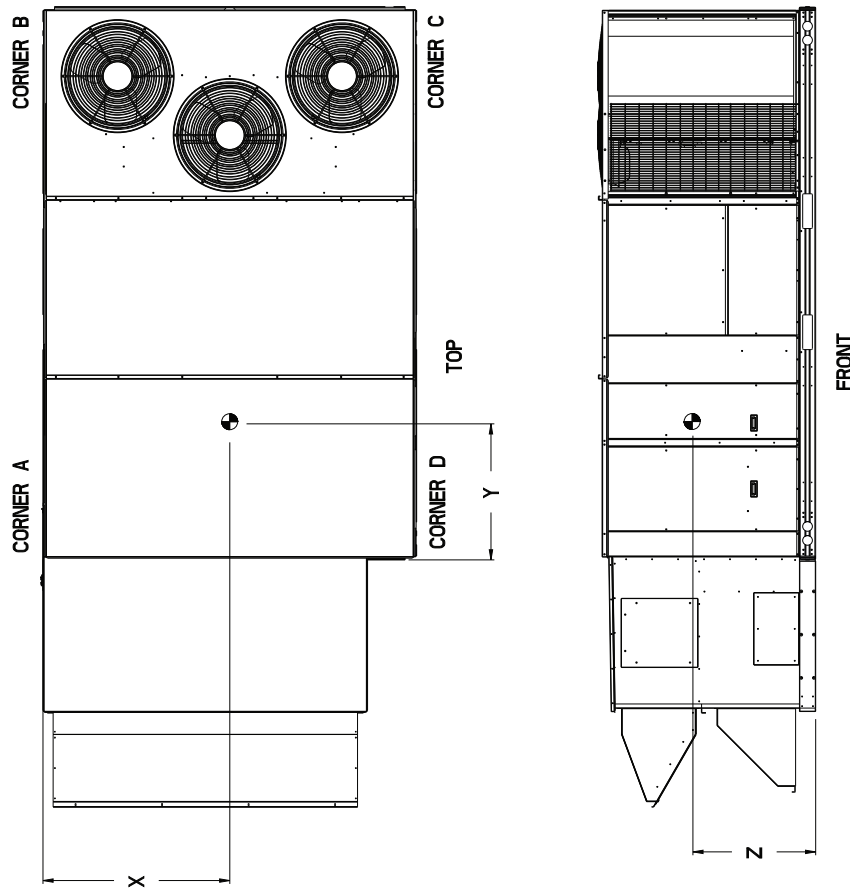

SHEET 2 OF 2	DATE 10/03/14	SUPERSEDES 10/31/11	50HC 17 SINGLE ZONE ELECTRICAL COOLING WITH ELECTRIC HEAT AND ERV	50HE502609	REV C
-----------------	------------------	------------------------	--	------------	----------

SERVICE CLEARANCES — 50HC**17 UNITS WITH ENERGYX SYSTEM

UNIT	ERV **	STD UNIT WEIGHT *		CORNER WEIGHT (A)		CORNER WEIGHT (B)		CORNER WEIGHT (C)		CORNER WEIGHT (D)		C.G.		
		LBS.	KG.	LBS.	KG.	LBS.	KG.	LBS.	KG.	LBS.	KG.	X	Y	Z
50HC17	HIGH CFM	3231	1469	1133	515	480	218	481	219	1136	516	43 1/8 [1095]	38 [965]	16 1/2 [419]
50HC17	LOW CFM	2835	1286	991	449	584	265	467	212	793	360	38 3/8 (975)	47 3/8 (1205)	19 1/4 (488)

* STANDARD UNIT WEIGHT IS WITHOUT ELECTRIC HEAT AND WITHOUT PACKAGING.
FOR OTHER OPTIONS AND ACCESSORIES, REFER TO THE PRODUCT DATA CATALOG.

** FOR COMFORT LINK UNITS, ONLY HIGH CFM ERV IS AVAILABLE.

NOTE:

UNIT IS NOT DESIGNED TO HAVE OVERHEAD OBSTRUCTION. CONTACT APPLICATION ENGINEERING FOR GUIDANCE ON ANY APPLICATION PLANNING OVERHEAD OBSTRUCTION OF FOR VERTICAL CLEARANCES.

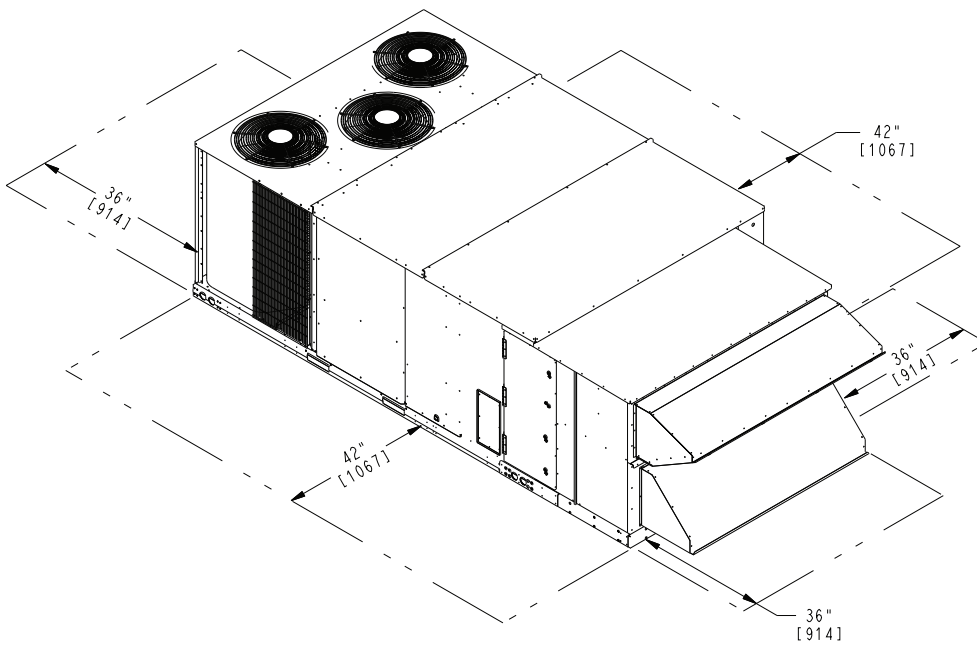

CLEARANCES

WARNING:

DO NOT LIFT UNIT THROUGH FORK LIFT OPENINGS IN UNIT BASERAIL. PER RIGGING LABEL INSTRUCTIONS, UNIT MUST BE LIFTED BY AN OVERHEAD LIFTING DEVICE

UNIT DIMENSIONAL DRAWING — 50HC**20 UNITS WITH ENERGYX SYSTEM

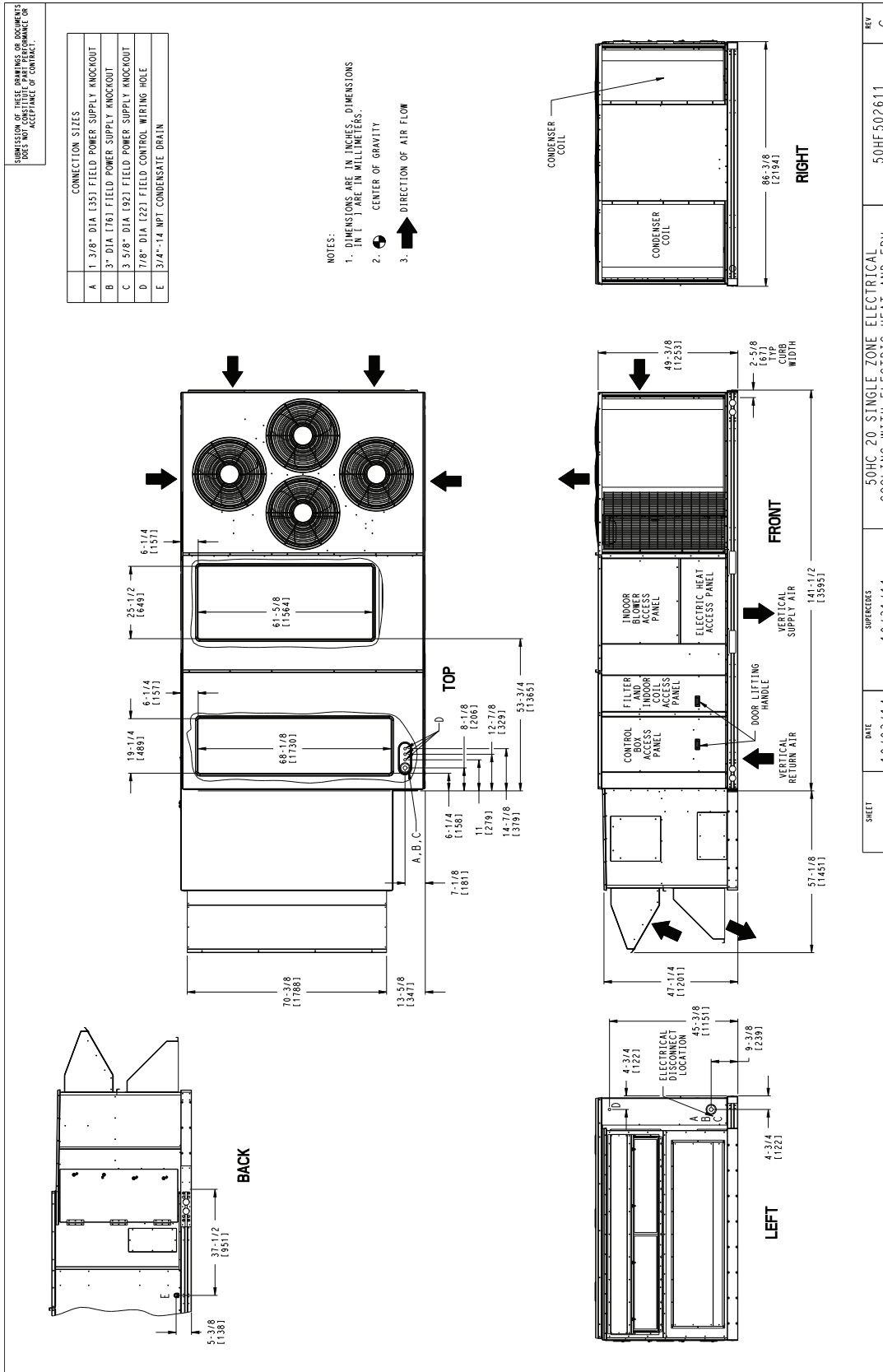

SHEET	DATE	SUPERSEDES	50HC 20 SINGLE ZONE ELECTRICAL COOLING WITH ELECTRIC HEAT AND ERY	REV
1 OF 2	10/03/14	10/31/11	50HE502611	C

UNIT DIMENSIONAL DRAWING — 50HC**20 UNITS WITH ENERGYX SYSTEM (cont)

NUMBER OF THESE DRAWINGS OF UNITS'S
 DOES NOT CONSTITUTE ANY PERFORMANCE OF
 ACCEPTANCE OF CONTRACT.

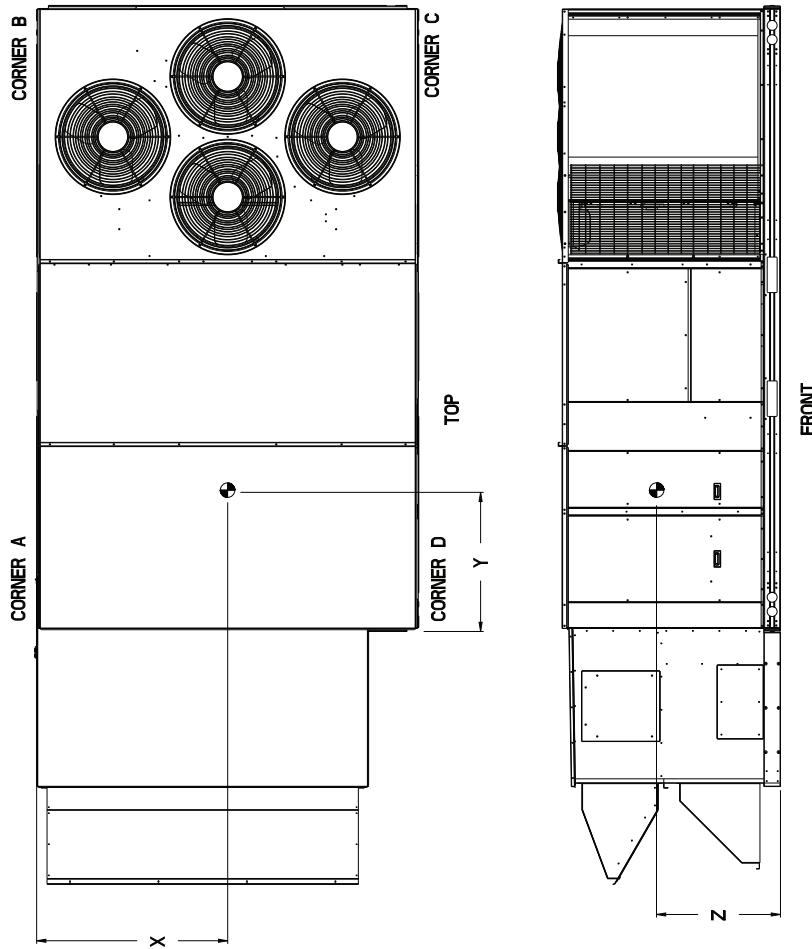

SHEET 2 OF 2	DATE 10/03/14	SUPERSEDES 10/31/11	50HC 20 SINGLE ZONE ELECTRICAL COOLING WITH ELECTRIC HEAT AND ERY	50HE502611	REV C
-----------------	------------------	------------------------	--	------------	----------

SERVICE CLEARANCES — 50HC**20 UNITS WITH ENERGYX SYSTEM

UNIT	ERV **	STD. UNIT WEIGHT *		CORNER WEIGHT (A)		CORNER WEIGHT (B)		CORNER WEIGHT (C)		CORNER WEIGHT (D)		C.G.		
		LBS.	KG.	LBS.	KG.	LBS.	KG.	LBS.	KG.	LBS.	KG.	X	Y	Z
50HC20	HIGH CFM	3441	1564	1157	526	427	194	574	261	1114	507	42 1/4 [1074]	48 [1220]	16 1/2 [419]
50HC20	LOW CFM	3030	1374	1011	459	555	252	519	235	945	429	41 3/4 (1060)	50 1/8 (1274)	19 (484)

* STANDARD UNIT WEIGHT IS WITHOUT ELECTRIC HEAT AND WITHOUT PACKAGING. FOR OTHER OPTIONS AND ACCESSORIES, REFER TO THE PRODUCT DATA CATALOG.

** FOR COMFORT LINK UNITS, ONLY HIGH CFM ERV IS AVAILABLE.

NOTE:

UNIT IS NOT DESIGNED TO HAVE OVERHEAD OBSTRUCTION. CONTACT APPLICATION ENGINEERING FOR GUIDANCE ON ANY APPLICATION PLANNING OVERHEAD OBSTRUCTION OF FOR VERTICAL CLEARANCES.

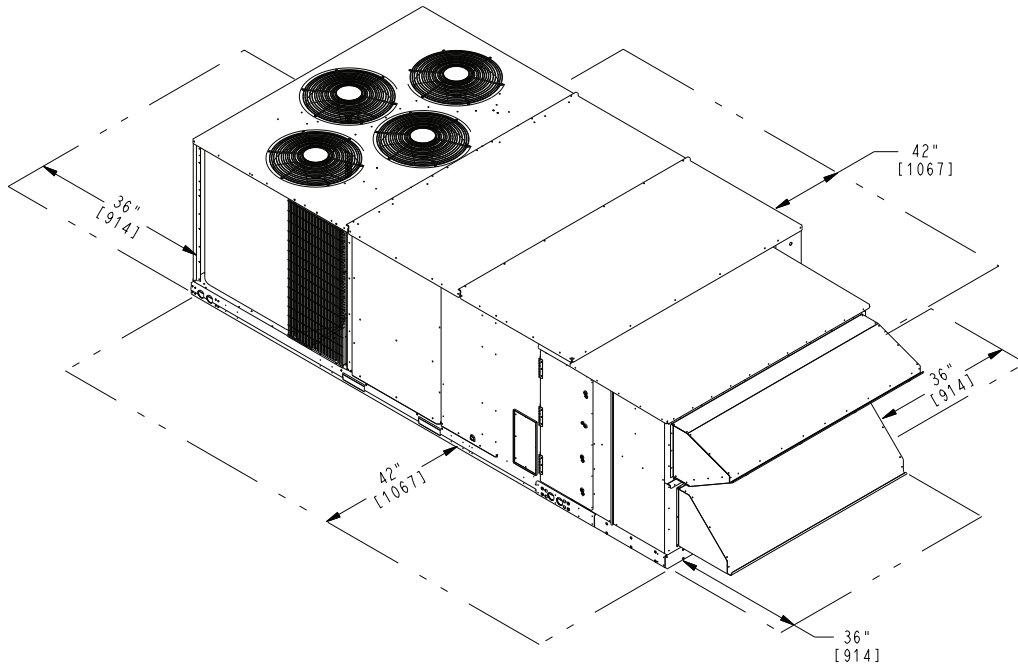

CLEARANCES

WARNING:

DO NOT LIFT UNIT THROUGH FORK LIFT OPENINGS IN UNIT BASERAIL. PER RIGGING LABEL INSTRUCTIONS, UNIT MUST BE LIFTED BY AN OVERHEAD LIFTING DEVICE

UNIT DIMENSIONAL DRAWING — 50HC**24 UNITS WITH ENERGYX SYSTEM

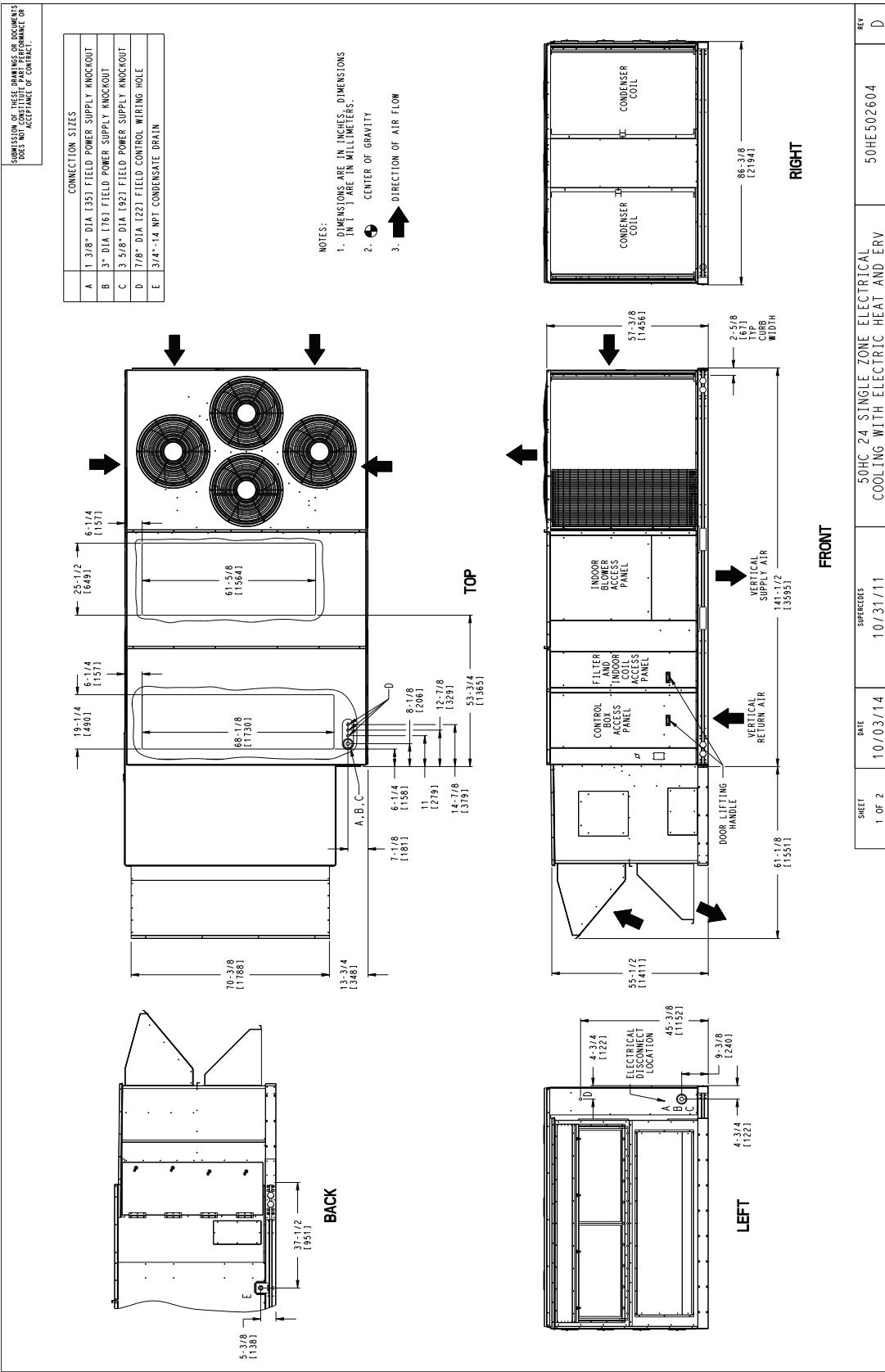

UNIT DIMENSIONAL DRAWING — 50HC**24 UNITS WITH ENERGYX SYSTEM (cont)

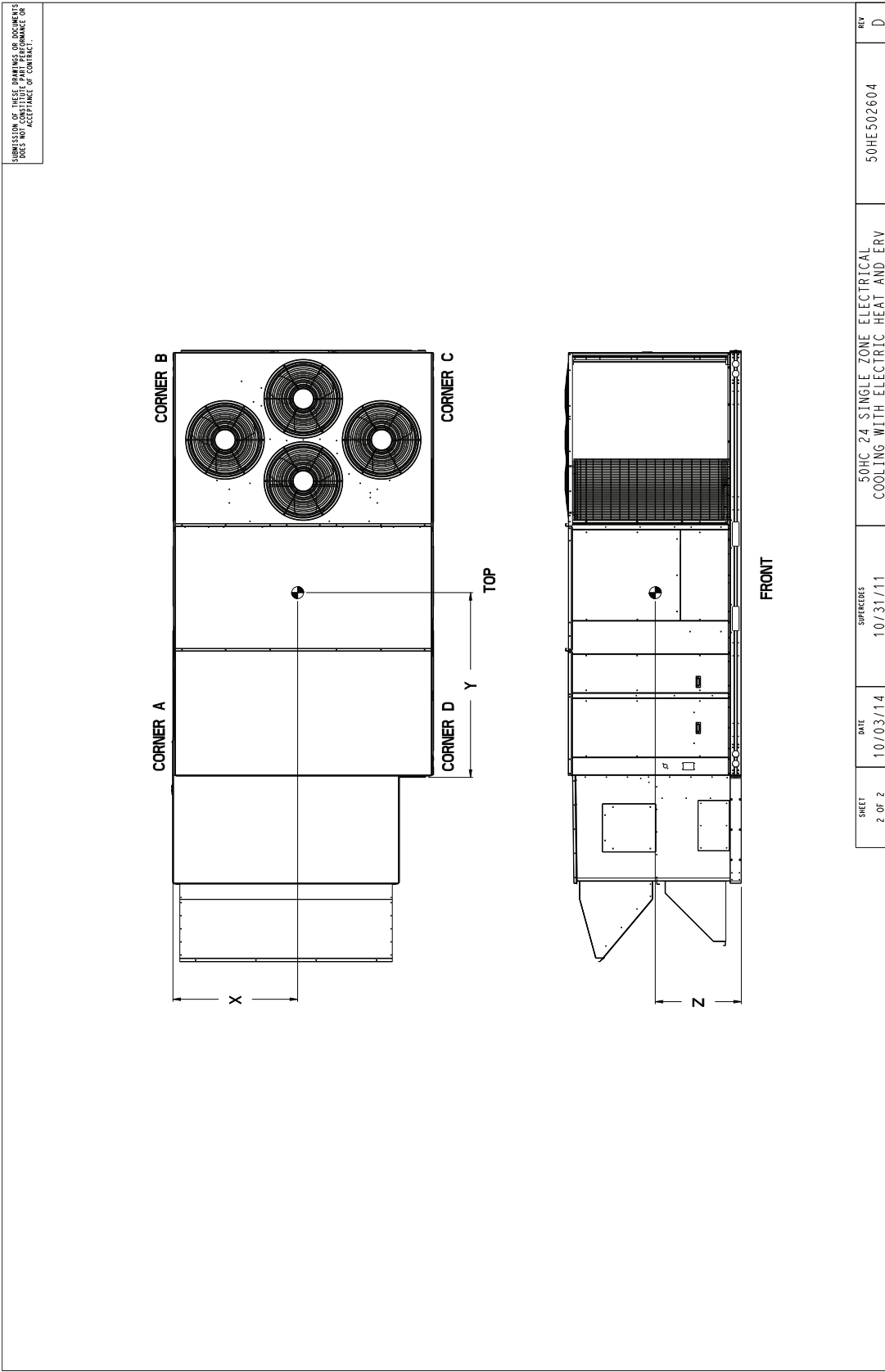

SERVICE CLEARANCES — 50HC**24 UNITS WITH ENERGYX SYSTEM

UNIT	ERV **	STD. UNIT WEIGHT *		CORNER WEIGHT (A)		CORNER WEIGHT (B)		CORNER WEIGHT (C)		CORNER WEIGHT (D)		C.G.		
		LBS.	KG.	LBS.	KG.	LBS.	KG.	LBS.	KG.	LBS.	KG.	X	Y	Z
50HC24	HIGH CFM	3796	1725	1366	621	704	320	587	267	1139	518	39 1/8 [995]	48 [1220]	19 [483]
50HC24	LOW CFM	3443	1562	1229	557	639	290	539	245	1036	470	39 1/2 [1004]	48 3/8 [1230]	22 1/2 [570]

* STANDARD UNIT WEIGHT IS WITHOUT ELECTRIC HEAT AND WITHOUT PACKAGING. FOR OTHER OPTIONS AND ACCESSORIES, REFER TO THE PRODUCT DATA CATALOG.

** FOR COMFORT LINK UNITS, ONLY HIGH CFM ERV IS AVAILABLE.

NOTE:

UNIT IS NOT DESIGNED TO HAVE OVERHEAD OBSTRUCTION. CONTACT APPLICATION ENGINEERING FOR GUIDANCE ON ANY APPLICATION PLANNING OVERHEAD OBSTRUCTION OF FOR VERTICAL CLEARANCES.

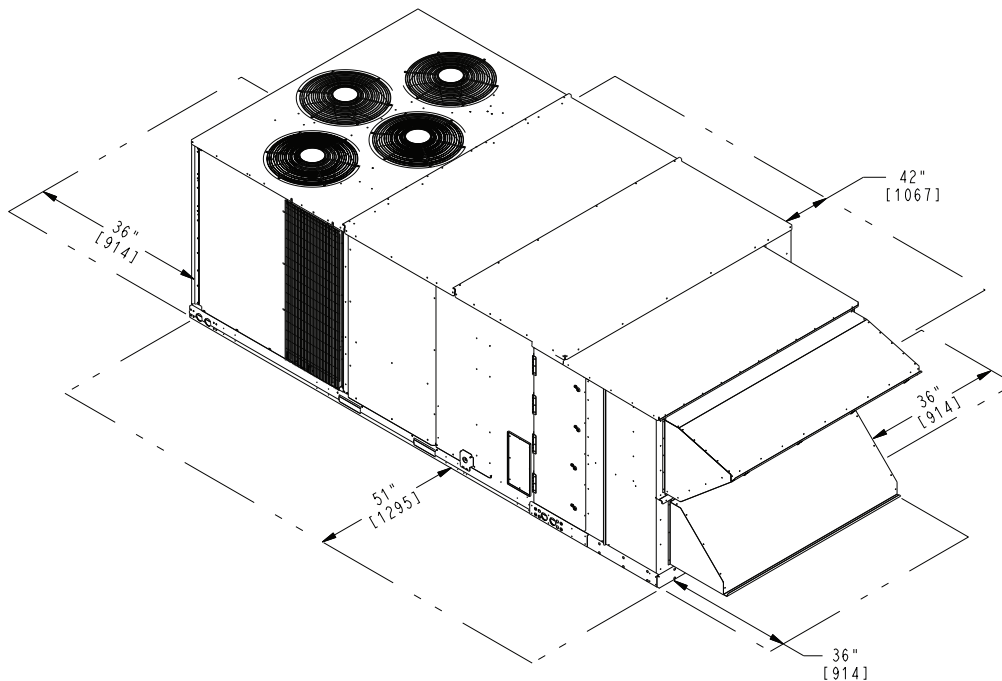

CLEARANCES

WARNING:

DO NOT LIFT UNIT THROUGH FORK LIFT OPENINGS IN UNIT BASERAIL. PER RIGGING LABEL INSTRUCTIONS, UNIT MUST BE LIFTED BY AN OVERHEAD LIFTING DEVICE

UNIT DIMENSIONAL DRAWING — 50HC**28 UNITS WITH ENERGYX SYSTEM

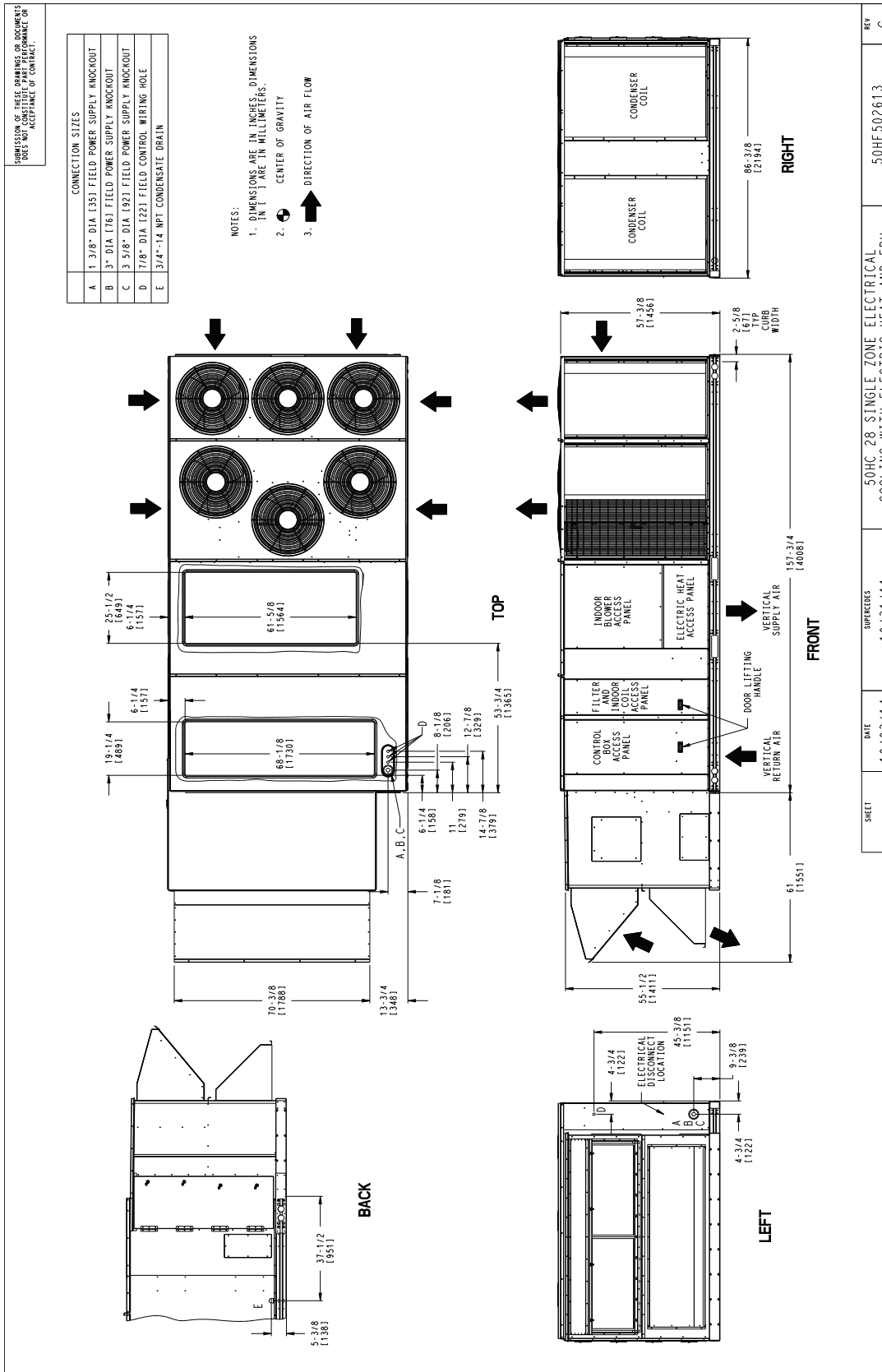

SHEET	DATE	SUPERSEDES	REV
1 OF 2	10/03/14	10/31/11	C

50HC 28 SINGLE ZONE ELECTRICAL COOLING WITH ELECTRIC HEAT AND ERV
50HE502613

UNIT DIMENSIONAL DRAWING — 50HC**28 UNITS WITH ENERGYX SYSTEM (cont)

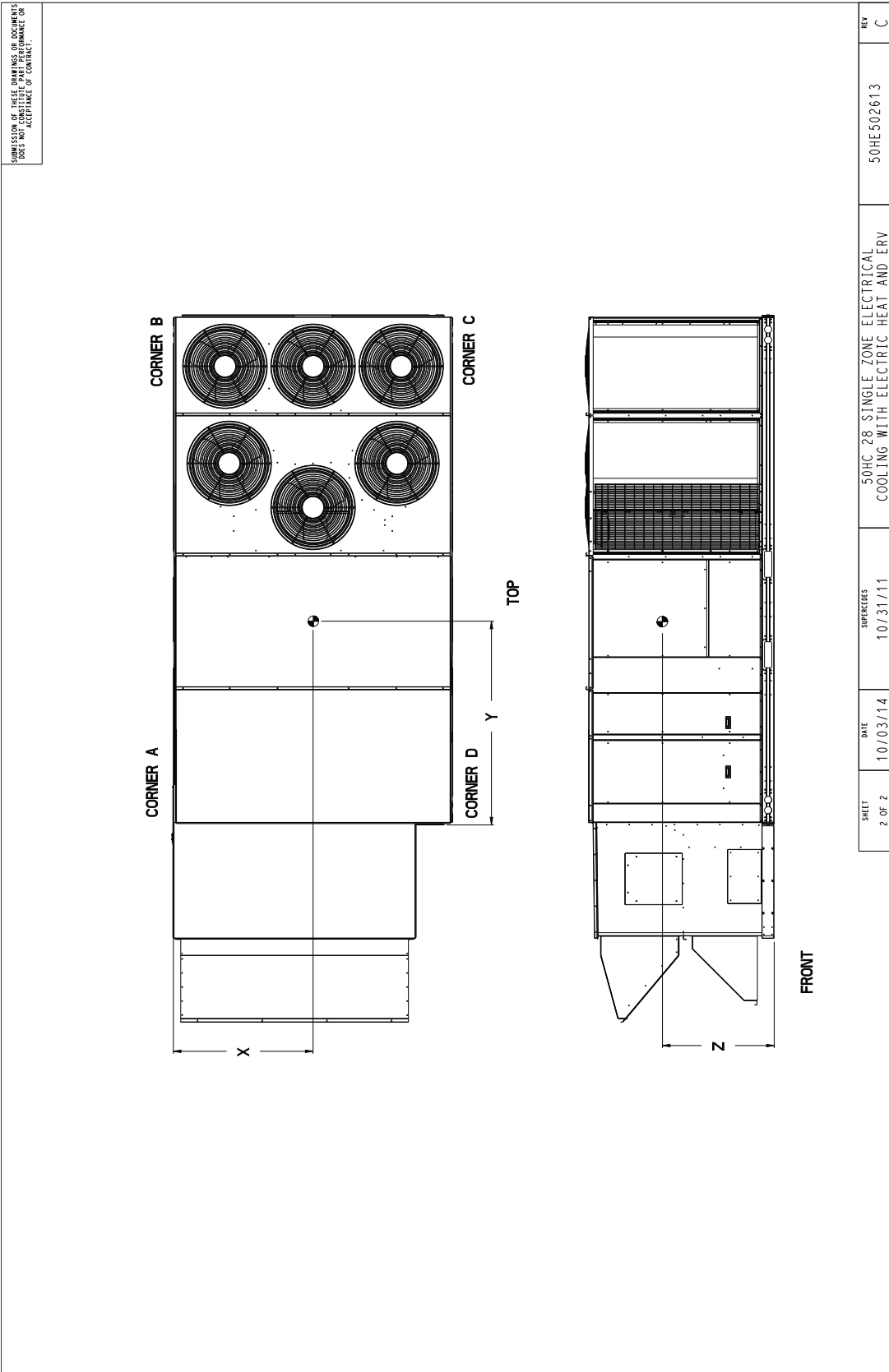

SERVICE CLEARANCES — 50HC**28 UNITS WITH ENERGYX SYSTEM

UNIT	ERV **	STD UNIT WEIGHT *		CORNER WEIGHT (A)		CORNER WEIGHT (B)		CORNER WEIGHT (C)		CORNER WEIGHT (D)		C.G.		
		LBS.	KG.	LBS.	KG.	LBS.	KG.	LBS.	KG.	LBS.	KG.	X	Y	Z
50HC28	HIGH CFM	3841	1746	1417	644	692	315	568	258	1164	529	38 7/8 [987]	51 3/4 [1313]	19 [483]
50HC28	LOW CFM	3488	1582	1272	577	633	287	526	238	1057	479	39 1/4 [995]	52 3/8 [1331]	22 3/8 [569]

* STANDARD UNIT WEIGHT IS WITHOUT ELECTRIC HEAT AND WITHOUT PACKAGING. FOR OTHER OPTIONS AND ACCESSORIES, REFER TO THE PRODUCT DATA CATALOG.

** FOR COMFORT LINK UNITS, ONLY HIGH CFM ERV IS AVAILABLE.

NOTE:
UNIT IS NOT DESIGNED TO HAVE OVERHEAD OBSTRUCTION. CONTACT APPLICATION ENGINEERING FOR GUIDANCE ON ANY APPLICATION PLANNING OVERHEAD OBSTRUCTION OF FOR VERTICAL CLEARANCES.

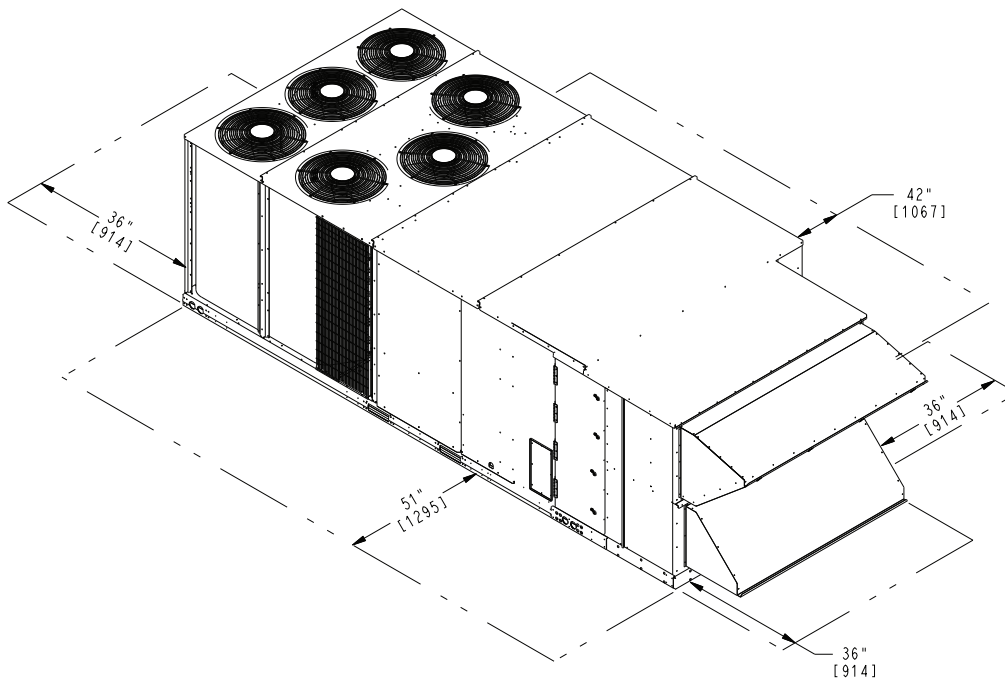

CLEARANCES

WARNING:
DO NOT LIFT UNIT THROUGH FORK LIFT OPENINGS IN UNIT BASERAIL. PER RIGGING LABEL INSTRUCTIONS, UNIT MUST BE LIFTED BY AN OVERHEAD LIFTING DEVICE

ROOF CURB DIMENSIONS — SIZE 50HC**17

UNIT SIZE	"A"	ROOF CURB ACCESSORY
17	1'-2" [356.0] 2'-0" [610.0]	CRRFCURB045A00 CRRFCURB046A00

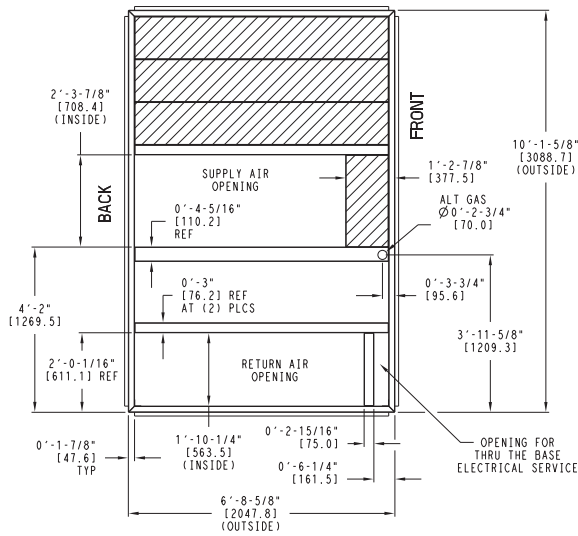

NOTES:

- 1 ROOF CURB ACCESSORY IS SHIPPED UNASSEMBLED.
- 2 DIMENSIONS IN [] ARE IN MILLIMETERS.
- 3 ROOF CURB GALVANIZED STEEL.
- 4 ATTACH DUCTWORK TO CURB (FLANGES ON DUCT REST ON CURB)
- 5 SERVICE CLEARANCE 4 FT ON EACH SIDE

➔ DIRECTION OF AIR FLOW

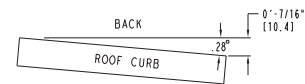

MAX CURB LEVELING TOLERANCES

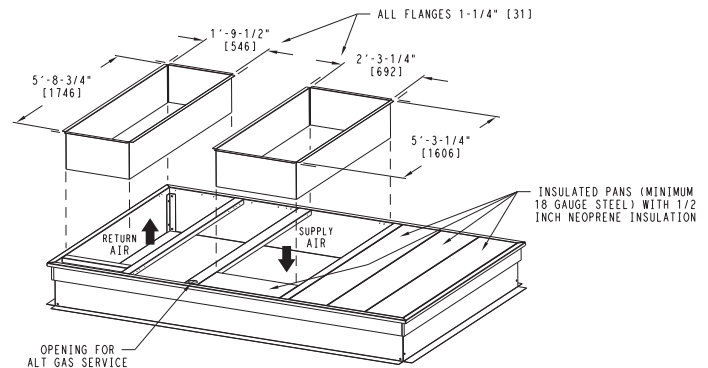
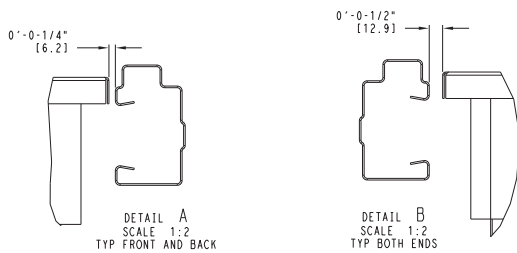
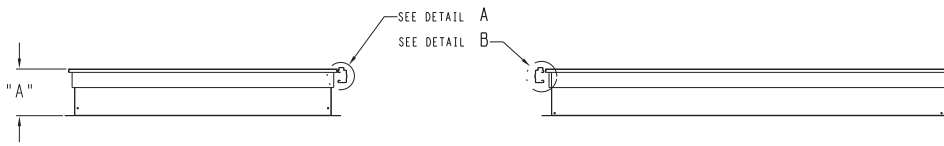
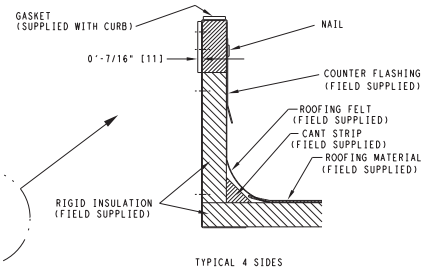
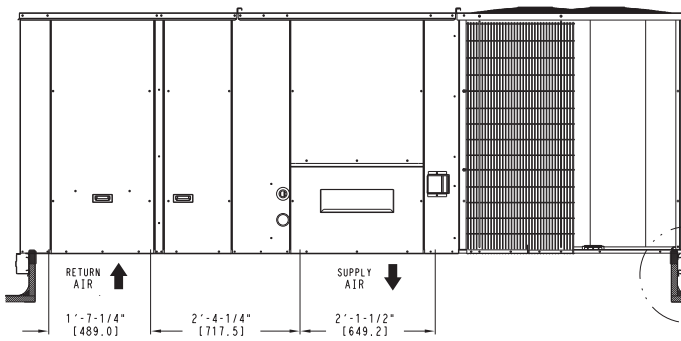

ROOF CURB DIMENSIONS — SIZE 50HC**20-24

UNIT SIZE	"A"	ROOF CURB ACCESSORY
20, 24	1'-2" [356.0] 2'-0" [610.0]	CRRFCURB04TA00 CRRFCURB04BA00

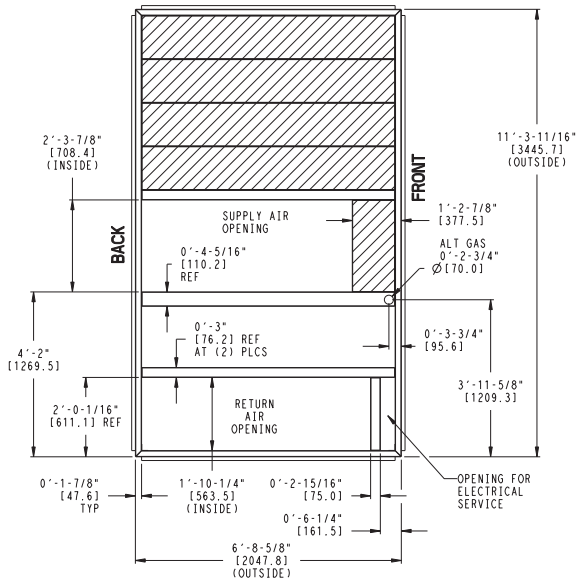

NOTES:

1. ROOF CURB ACCESSORY IS SHIPPED UNASSEMBLED.
2. DIMENSIONS IN [] ARE IN MILLIMETERS.
3. ROOF CURB GALVANIZED STEEL.
4. ATTACH DUCTWORK TO CURB (FLANGES ON DUCT REST ON CURB)
5. SERVICE CLEARANCE 4 FT ON EACH SIDE

➔ DIRECTION OF AIR FLOW

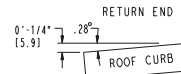
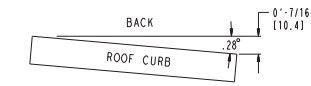

MAX CURB LEVELING TOLERANCES

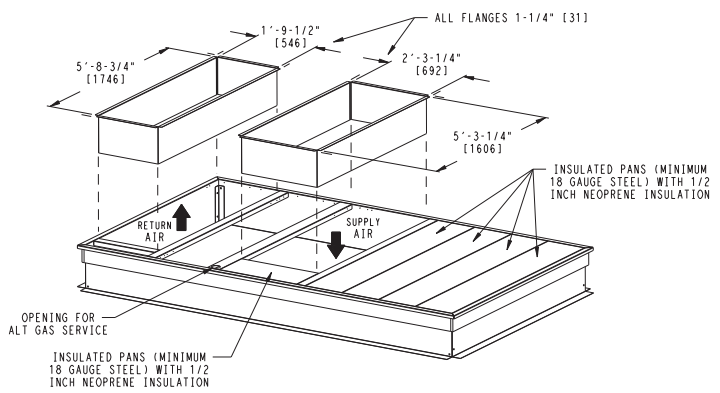
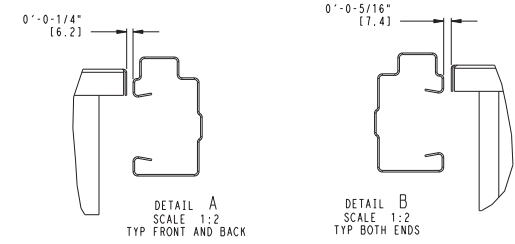
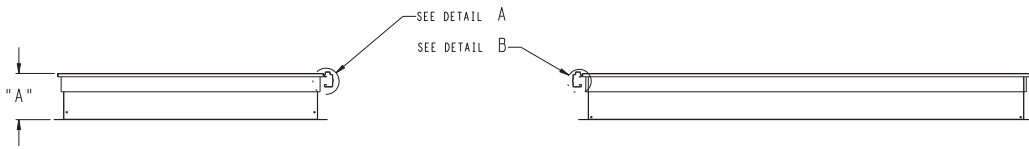
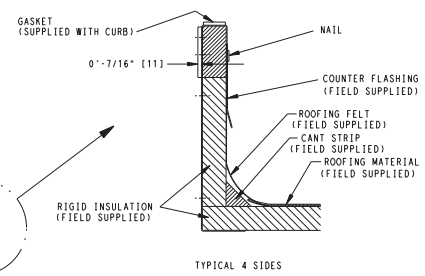
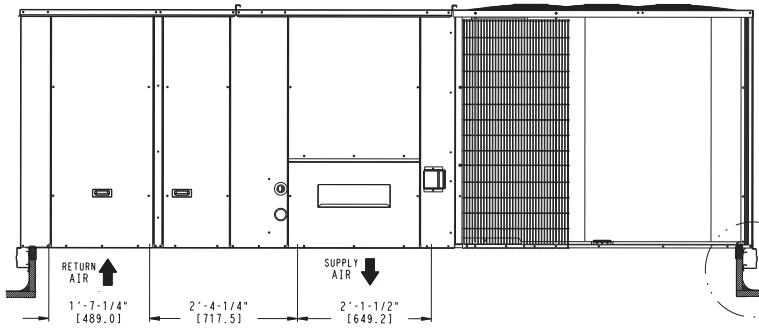

ROOF CURB DIMENSIONS — SIZE 50HC**28

UNIT SIZE	"A"	ROOF CURB ACCESSORY
28	1'-2" [356.0] 2'-0" [610.0]	CRRFCURB049A00 CRRFCURB050A00

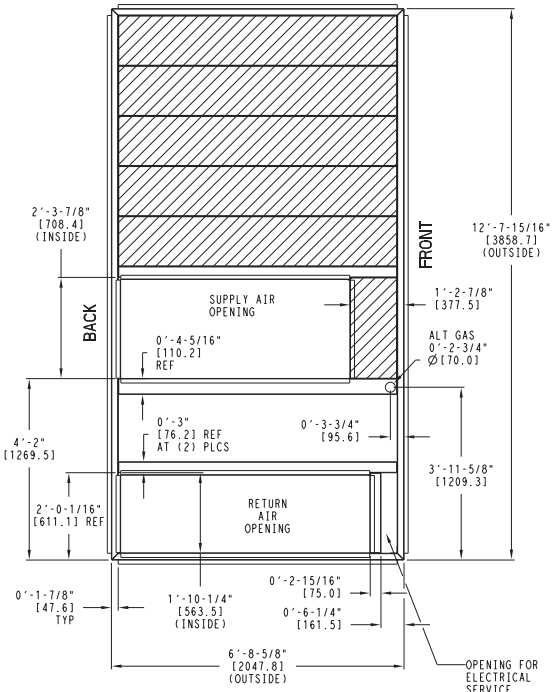

- NOTES:**
- 1 ROOF CURB ACCESSORY IS SHIPPED UNASSEMBLED.
 - 2 BOLT HEADS TO BE ON INSIDE OF FLANGE. CLEARANCE IS (11) 0'-0-7/16" TYP ALL CORNERS.
 - 3 DIMENSIONS IN [] ARE IN MILLIMETERS.
 - 4 ROOF CURB GALVANIZED STEEL.
 - 5 ATTACH DUCTWORK TO CURB (FLANGES ON DUCT REST ON CURB)
 - 6 SERVICE CLEARANCE 4 FT ON EACH SIDE
 - 7 GAS SERVICE PLATE IS PART OF A SEPARATELY SHIPPED ACCESSORY PACKAGE.
 - 8 GAS SERVICE PLATE CAN BE USED WITH EITHER ACCESSORY ROOFCURB.
- ➔ DIRECTION OF AIR FLOW

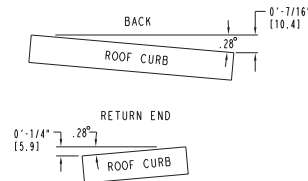

MAX CURB LEVELING TOLERANCES

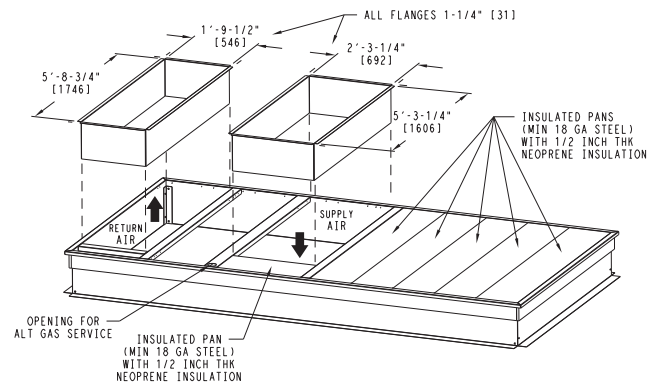
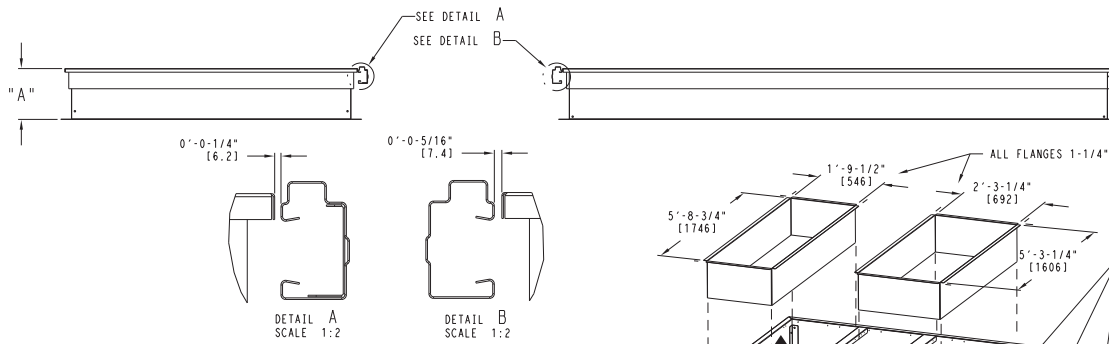
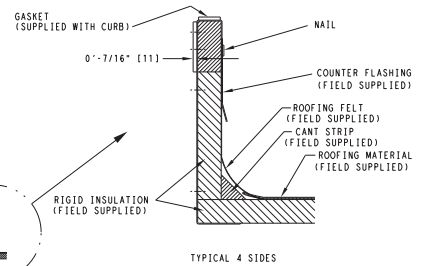
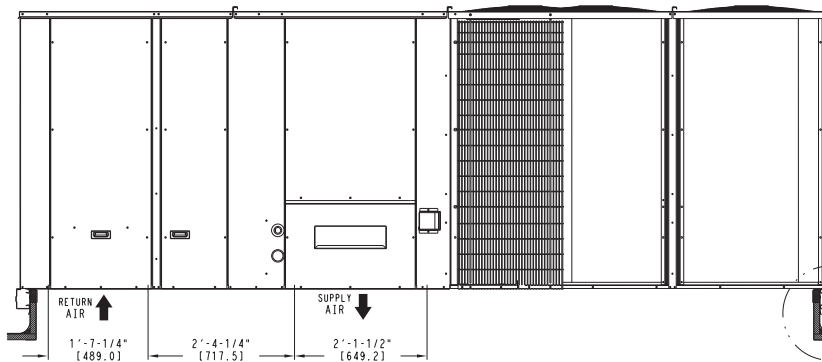

50HC*D17 — 15 TON — COOLING CAPACITIES

50HC*D17				AMBIENT TEMPERATURE (F)															
				85			95			105			115			125			
				EAT (db)			EAT (db)			EAT (db)			EAT (db)			EAT (db)			
				75	80	85	75	80	85	75	80	85	75	80	85	75	80	85	
4500 Cfm	EAT (wb)	58	TC	158.3	158.3	179.2	152.6	152.6	172.9	146.6	146.6	166.1	140.2	140.2	158.8	133.2	133.2	150.8	
			SHC	137.3	158.3	179.2	132.4	152.6	172.9	127.2	146.6	166.1	121.6	140.2	158.8	115.5	133.2	150.8	
		62	TC	166.8	166.8	169.0	159.5	159.5	165.6	151.8	151.8	161.9	143.6	143.6	157.9	134.9	134.9	153.4	
			SHC	123.1	146.1	169.0	119.7	142.6	165.6	116.1	139.0	161.9	112.3	135.1	157.9	108.2	130.8	153.4	
		67	TC	182.9	182.9	182.9	174.9	174.9	174.9	166.3	166.3	166.3	157.2	157.2	157.2	147.6	147.6	147.6	
			SHC	100.0	123.1	146.1	96.7	119.8	142.8	93.2	116.3	139.4	89.7	112.7	135.7	85.9	108.9	131.9	
	72	TC	200.5	200.5	200.5	191.6	191.6	191.6	182.2	182.2	182.2	172.2	172.2	172.2	161.7	161.7	161.7		
		SHC	76.1	99.5	122.8	72.9	96.2	119.5	69.5	92.8	116.1	66.0	89.3	112.5	62.4	85.6	108.8		
	76	TC	—	215.4	215.4	—	205.8	205.8	—	195.6	195.6	—	184.8	184.8	—	173.6	173.6		
		SHC	—	80.2	105.0	—	77.1	101.7	—	73.7	98.2	—	70.2	94.5	—	66.7	90.7		
	5250 Cfm	EAT (wb)	58	TC	166.7	166.7	188.8	160.6	160.6	181.9	154.0	154.0	174.4	147.0	147.0	166.5	139.5	139.5	157.9
				SHC	144.6	166.7	188.8	139.3	160.6	181.9	133.6	154.0	174.4	127.6	147.0	166.5	121.0	139.5	157.9
62			TC	172.0	172.0	185.1	164.3	164.3	181.2	156.3	156.3	177.0	147.8	147.8	172.4	139.6	139.6	164.3	
			SHC	132.5	158.8	185.1	128.9	155.1	181.2	125.0	151.0	177.0	120.9	146.6	172.4	114.9	139.6	164.3	
67			TC	188.3	188.3	188.3	179.7	179.7	179.7	170.7	170.7	170.7	161.0	161.0	161.0	150.9	150.9	150.9	
			SHC	106.1	132.7	159.3	102.8	129.3	155.9	99.3	125.8	152.4	95.6	122.1	148.6	91.7	118.2	144.7	
72		TC	206.1	206.1	206.1	196.7	196.7	196.7	186.7	186.7	186.7	176.2	176.2	176.2	165.3	165.3	165.3		
		SHC	78.8	105.6	132.5	75.5	102.3	129.1	72.1	98.8	125.6	68.5	95.2	121.9	64.8	91.4	118.0		
76		TC	—	221.2	221.2	—	211.0	211.0	—	200.3	200.3	—	189.0	189.0	—	177.2	177.2		
		SHC	—	83.6	111.7	—	80.3	108.2	—	76.9	104.6	—	73.3	100.9	—	69.7	97.1		
6000 Cfm		EAT (wb)	58	TC	173.8	173.8	196.8	167.2	167.2	189.4	160.2	160.2	181.4	152.7	152.7	173.0	144.7	144.7	163.8
				SHC	150.8	173.8	196.8	145.1	167.2	189.4	139.0	160.2	181.4	132.5	152.7	173.0	125.5	144.7	163.8
	62		TC	176.3	176.3	199.5	168.5	168.5	194.9	160.5	160.5	188.9	152.9	152.9	179.9	144.8	144.8	170.4	
			SHC	140.9	170.2	199.5	136.9	165.9	194.9	132.1	160.5	188.9	125.8	152.9	179.9	119.2	144.8	170.4	
	67		TC	192.3	192.3	192.3	183.4	183.4	183.4	173.9	173.9	173.9	164.0	164.0	164.0	153.4	153.4	156.9	
			SHC	112.0	142.0	172.0	108.5	138.5	168.5	104.9	134.9	164.8	101.2	131.1	161.0	97.2	127.1	156.9	
	72	TC	210.4	210.4	210.4	200.6	200.6	200.6	190.2	190.2	190.2	179.3	179.3	179.3	167.9	167.9	167.9		
		SHC	81.2	111.4	141.7	77.9	108.0	138.2	74.4	104.5	134.6	70.7	100.8	130.8	67.0	96.9	126.9		
	76	TC	—	225.6	225.6	—	215.0	215.0	—	203.8	203.8	—	192.1	192.1	—	180.0	180.0		
		SHC	—	86.7	117.9	—	83.3	114.5	—	79.9	110.8	—	76.3	107.1	—	72.6	103.2		
	6750 Cfm	EAT (wb)	58	TC	179.8	179.8	203.7	172.9	172.9	195.8	165.5	165.5	187.4	157.5	157.5	178.4	149.0	149.0	168.8
				SHC	156.0	179.8	203.7	150.0	172.9	195.8	143.5	165.5	187.4	136.7	157.5	178.4	129.3	149.0	168.8
62			TC	180.5	180.5	210.7	173.0	173.0	203.6	165.6	165.6	194.9	157.7	157.7	185.5	149.1	149.1	175.5	
			SHC	147.6	179.2	210.7	142.4	173.0	203.6	136.3	165.6	194.9	129.8	157.7	185.5	122.8	149.1	175.5	
67			TC	195.6	195.6	195.6	186.2	186.2	186.2	176.5	176.5	176.8	166.2	166.2	172.7	155.4	155.4	168.4	
			SHC	117.5	150.8	184.1	114.0	147.3	180.5	110.4	143.6	176.8	106.5	139.6	172.7	102.4	135.4	168.4	
72		TC	213.8	213.8	213.8	203.6	203.6	203.6	192.9	192.9	192.9	181.6	181.6	181.6	169.9	169.9	169.9		
		SHC	83.5	117.0	150.5	80.1	113.5	147.0	76.5	109.9	143.3	72.8	106.1	139.4	69.1	102.3	135.5		
76		TC	—	229.1	229.1	—	218.1	218.1	—	206.6	206.6	—	194.6	194.6	—	182.1	182.1		
		SHC	—	89.6	124.0	—	86.2	120.5	—	82.7	116.8	—	79.0	113.0	—	75.2	109.0		
7500 Cfm		EAT (wb)	58	TC	185.1	185.1	209.6	177.7	177.7	201.3	170.0	170.0	192.5	161.6	161.6	183.0	152.8	152.8	173.0
				SHC	160.6	185.1	209.6	154.2	177.7	201.3	147.5	170.0	192.5	140.2	161.6	183.0	132.5	152.8	173.0
	62		TC	185.2	185.2	218.0	177.9	177.9	209.3	170.1	170.1	200.2	161.8	161.8	190.4	152.9	152.9	179.9	
			SHC	152.5	185.2	218.0	146.4	177.9	209.3	140.0	170.1	200.2	133.2	161.8	190.4	125.8	152.9	179.9	
	67		TC	198.1	198.1	198.1	188.6	188.6	192.1	178.6	178.6	188.1	168.1	168.1	183.8	157.2	157.2	179.1	
			SHC	122.8	159.3	195.9	119.2	155.7	192.1	115.5	151.8	188.1	111.5	147.7	183.8	107.3	143.2	179.1	
	72	TC	216.6	216.6	216.6	206.1	206.1	206.1	195.1	195.1	195.1	183.5	183.5	183.5	171.6	171.6	171.6		
		SHC	85.6	122.3	159.0	82.2	118.8	155.5	78.6	115.2	151.7	74.9	111.3	147.8	71.1	107.4	143.8		
	76	TC	—	231.9	231.9	—	220.7	220.7	—	208.9	208.9	—	196.5	196.5	—	183.8	183.8		
		SHC	—	92.4	129.9	—	88.9	126.3	—	85.4	122.6	—	81.6	118.7	—	77.8	114.6		

LEGEND

- Do Not Operate
- Cfm — Cubic Feet Per Minute (Supply Air)
- EAT (db) — Entering Air Temperature (Dry Bulb)
- EAT (wb) — Entering Air Temperature (Wet Bulb)
- SHC — Sensible Heat Capacity (1000 Btuh) Gross
- TC — Total Capacity (1000 Btuh) Gross

NOTE: See Minimum-Maximum Airflow Ratings table on page 5. Do not operate outside these limits.



50HC*D20 — 17.5 TON — COOLING CAPACITIES

50HC*D20				AMBIENT TEMPERATURE (F)															
				85			95			105			115			125			
				EAT (db)			EAT (db)			EAT (db)			EAT (db)			EAT (db)			
		75	80	85	75	80	85	75	80	85	75	80	85	75	80	85			
5250 Cfm	EAT (wb)	58	THC	185.1	185.1	209.2	178.7	178.7	201.9	171.8	171.8	194.1	164.5	164.5	185.8	156.7	156.7	177.0	
			SHC	161.1	185.1	209.2	155.4	178.7	201.9	149.4	171.8	194.1	143.1	164.5	185.8	136.3	156.7	177.0	
		62	THC	193.8	193.8	199.5	185.6	185.6	195.4	176.9	176.9	191.1	167.7	167.7	186.4	158.2	158.2	181.1	
			SHC	145.6	172.6	199.5	141.7	168.6	195.4	137.6	164.4	191.1	133.2	159.8	186.4	128.3	154.7	181.1	
		67	THC	212.2	212.2	212.2	203.3	203.3	203.3	193.8	193.8	193.8	183.8	183.8	183.8	173.1	173.1	173.1	
			SHC	119.0	146.0	173.1	115.3	142.3	169.4	111.4	138.4	165.4	107.3	134.3	161.3	103.0	130.0	157.0	
	72	THC	232.3	232.3	232.3	222.7	222.7	222.7	212.4	212.4	212.4	201.6	201.6	201.6	190.1	190.1	190.1		
		SHC	91.5	118.8	146.2	87.9	115.2	142.5	84.1	111.4	138.7	80.2	107.4	134.6	76.0	103.2	130.4		
	76	THC	—	249.5	249.5	—	239.2	239.2	—	228.2	228.2	—	216.6	216.6	—	204.3	204.3		
		SHC	—	96.7	125.3	—	93.2	121.7	—	89.5	117.9	—	85.6	113.8	—	81.5	109.5		
	6125 Cfm	EAT (wb)	58	THC	194.7	194.7	220.0	187.8	187.8	212.2	180.4	180.4	203.8	172.5	172.5	194.9	164.1	164.1	185.5
				SHC	169.4	194.7	220.0	163.3	187.8	212.2	156.9	180.4	203.8	150.1	172.5	194.9	142.8	164.1	185.5
62			THC	199.6	199.6	218.0	191.1	191.1	213.5	182.1	182.1	208.4	173.0	173.0	201.2	164.3	164.3	192.8	
			SHC	156.5	187.2	218.0	152.3	182.9	213.5	147.7	178.0	208.4	141.8	171.5	201.2	135.8	164.3	192.8	
67			THC	218.0	218.0	218.0	208.7	208.7	208.7	198.7	198.7	198.7	188.2	188.2	188.2	177.1	177.1	177.1	
			SHC	126.2	157.4	188.6	122.4	153.6	184.7	118.4	149.6	180.7	114.3	145.4	176.5	109.9	141.0	172.1	
72		THC	238.5	238.5	238.5	228.4	228.4	228.4	217.7	217.7	217.7	206.3	206.3	206.3	194.3	194.3	194.3		
		SHC	94.7	126.1	157.5	91.0	122.4	153.8	87.2	118.5	149.8	83.1	114.4	145.7	78.9	110.1	141.4		
76		THC	—	255.9	255.9	—	245.1	245.1	—	233.6	233.6	—	221.4	221.4	—	208.5	208.5		
		SHC	—	100.7	133.3	—	97.1	129.6	—	93.3	125.6	—	89.3	121.5	—	85.1	117.1		
7000 Cfm		EAT (wb)	58	THC	202.7	202.7	229.1	195.4	195.4	220.8	187.5	187.5	211.9	179.2	179.2	202.5	170.3	170.3	192.4
				SHC	176.4	202.7	229.1	170.0	195.4	220.8	163.1	187.5	211.9	155.9	179.2	202.5	148.1	170.3	192.4
	62		THC	204.6	204.6	234.4	196.0	196.0	228.0	187.7	187.7	220.3	179.3	179.3	210.5	170.4	170.4	200.0	
			SHC	166.0	200.2	234.4	160.8	194.4	228.0	155.1	187.7	220.3	148.2	179.3	210.5	140.8	170.4	200.0	
	67		THC	222.5	222.5	222.5	212.8	212.8	212.8	202.4	202.4	202.4	191.5	191.5	191.5	180.0	180.0	186.4	
			SHC	133.0	168.2	203.4	129.2	164.3	199.5	125.1	160.3	195.4	120.9	156.0	191.0	116.4	151.4	186.4	
	72	THC	243.3	243.3	243.3	232.7	232.7	232.7	221.6	221.6	221.6	209.9	209.9	209.9	197.4	197.4	197.4		
		SHC	97.5	132.9	168.3	93.8	129.2	164.5	89.9	125.2	160.5	85.8	121.1	156.3	81.6	116.7	151.9		
	76	THC	—	260.8	260.8	—	249.6	249.6	—	237.7	237.7	—	225.1	225.1	—	211.7	211.7		
		SHC	—	104.4	140.8	—	100.7	137.0	—	96.9	133.0	—	92.8	128.8	—	88.5	124.4		
	7875 Cfm	EAT (wb)	58	THC	209.6	209.6	236.8	201.8	201.8	228.1	193.6	193.6	218.8	184.8	184.8	208.9	175.5	175.5	198.3
				SHC	182.3	209.6	236.8	175.6	201.8	228.1	168.4	193.6	218.8	160.8	184.8	208.9	152.7	175.5	198.3
62			THC	209.8	209.8	246.2	202.0	202.0	237.1	193.8	193.8	227.4	185.0	185.0	217.1	175.6	175.6	206.1	
			SHC	173.4	209.8	246.2	167.0	202.0	237.1	160.1	193.8	227.4	152.9	185.0	217.1	145.1	175.6	206.1	
67			THC	226.1	226.1	226.1	216.0	216.0	216.0	205.4	205.4	209.4	194.2	194.2	204.8	182.4	182.4	199.9	
			SHC	139.6	178.6	217.7	135.6	174.7	213.7	131.5	170.5	209.4	127.1	166.0	204.8	122.5	161.2	199.9	
72		THC	247.0	247.0	247.0	236.2	236.2	236.2	224.7	224.7	224.7	212.7	212.7	212.7	199.9	199.9	199.9		
		SHC	100.2	139.5	178.8	96.5	135.7	174.9	92.5	131.7	170.9	88.4	127.5	166.6	84.1	123.1	162.1		
76		THC	—	264.7	264.7	—	253.1	253.1	—	240.9	240.9	—	227.9	227.9	—	—	—		
		SHC	—	107.9	148.1	—	104.2	144.3	—	100.2	140.2	—	96.1	135.9	—	—	—		
8750 Cfm		EAT (wb)	58	THC	215.4	215.4	243.4	207.3	207.3	234.3	198.7	198.7	224.6	189.6	189.6	214.2	179.9	179.9	203.2
				SHC	187.4	215.4	243.4	180.3	207.3	234.3	172.9	198.7	224.6	164.9	189.6	214.2	156.5	179.9	203.2
	62		THC	215.5	215.5	253.0	207.5	207.5	243.5	198.9	198.9	233.4	189.7	189.7	222.7	180.0	180.0	211.2	
			SHC	178.1	215.5	253.0	171.5	207.5	243.5	164.4	198.9	233.4	156.8	189.7	222.7	148.8	180.0	211.2	
	67		THC	228.9	228.9	231.5	218.7	218.7	227.3	207.8	207.8	222.8	196.4	196.4	217.9	184.5	184.5	212.6	
			SHC	145.8	188.6	231.5	141.8	184.5	227.3	137.5	180.1	222.8	133.0	175.5	217.9	128.2	170.4	212.6	
	72	THC	250.1	250.1	250.1	239.0	239.0	239.0	227.3	227.3	227.3	214.9	214.9	214.9	201.8	201.8	201.8		
		SHC	102.8	145.8	188.9	99.0	142.0	185.0	95.0	137.9	180.9	90.8	133.7	176.5	86.4	129.2	172.0		
	76	THC	—	267.8	267.8	—	256.0	256.0	—	243.5	243.5	—	230.2	230.2	—	—	—		
		SHC	—	111.2	155.2	—	107.4	151.3	—	103.5	147.1	—	99.3	142.8	—	—	—		

LEGEND

- Do Not Operate
- Cfm — Cubic Feet Per Minute (Supply Air)
- EAT (db) — Entering Air Temperature (Dry Bulb)
- EAT (wb) — Entering Air Temperature (Wet Bulb)
- SHC — Sensible Heat Capacity (1000 Btuh) Gross
- TC — Total Capacity (1000 Btuh) Gross

NOTE: See Minimum-Maximum Airflow Ratings table on page 5. Do not operate outside these limits.



50HC*D24 — 20 TON — COOLING CAPACITIES

50HC*D24				AMBIENT TEMPERATURE (F)															
				85			95			105			115			125			
				EAT (db)			EAT (db)			EAT (db)			EAT (db)			EAT (db)			
				75	80	85	75	80	85	75	80	85	75	80	85	75	80	85	
6000 Cfm	EAT (wb)	58	THC	214.4	214.4	242.5	207.0	207.0	234.2	199.0	199.0	225.1	190.2	190.2	215.2	180.6	180.6	204.3	
			SHC	186.3	214.4	242.5	179.9	207.0	234.2	173.0	199.0	225.1	165.3	190.2	215.2	157.0	180.6	204.3	
		62	THC	226.8	226.8	227.7	217.3	217.3	223.0	206.9	206.9	218.0	195.8	195.8	212.5	183.7	183.7	206.4	
			SHC	167.0	197.3	227.7	162.4	192.7	223.0	157.6	187.8	218.0	152.3	182.4	212.5	146.6	176.5	206.4	
		67	THC	248.4	248.4	248.4	237.9	237.9	237.9	226.6	226.6	226.6	214.3	214.3	214.3	201.0	201.0	201.0	
			SHC	136.5	167.1	197.6	132.2	162.7	193.2	127.5	158.0	188.4	122.5	152.9	183.4	117.2	147.6	178.0	
	72	THC	271.9	271.9	271.9	260.3	260.3	260.3	247.9	247.9	247.9	234.5	234.5	234.5	220.1	220.1	220.1		
		SHC	105.1	136.0	167.0	100.8	131.7	162.5	96.3	127.1	157.9	91.4	122.1	152.9	86.3	116.9	147.6		
	76	THC	—	291.7	291.7	—	279.2	279.2	—	265.7	265.7	—	251.3	251.3	—	235.8	235.8		
		SHC	—	110.7	143.7	—	106.5	139.5	—	102.0	134.7	—	97.2	129.7	—	92.1	124.3		
	7000 Cfm	EAT (wb)	58	THC	225.8	225.8	255.3	217.8	217.8	246.3	209.1	209.1	236.5	199.6	199.6	225.7	189.2	189.2	214.0
				SHC	196.2	225.8	255.3	189.3	217.8	246.3	181.7	209.1	236.5	173.4	199.6	225.7	164.4	189.2	214.0
62			THC	233.9	233.9	248.8	223.8	223.8	243.8	213.1	213.1	238.2	201.4	201.4	231.8	190.0	190.0	221.5	
			SHC	179.4	214.1	248.8	174.6	209.2	243.8	169.4	203.8	238.2	163.7	197.8	231.8	155.9	188.7	221.5	
67			THC	255.7	255.7	255.7	244.6	244.6	244.6	232.6	232.6	232.6	219.6	219.6	219.6	205.7	205.7	205.7	
			SHC	144.7	179.7	214.8	140.2	175.2	210.2	135.4	170.4	205.4	130.3	165.2	200.2	124.9	159.8	194.7	
72		THC	279.4	279.4	279.4	267.3	267.3	267.3	254.1	254.1	254.1	240.1	240.1	240.1	224.9	224.9	224.9		
		SHC	108.7	144.1	179.6	104.3	139.7	175.1	99.6	135.0	170.3	94.7	129.9	165.1	89.5	124.6	159.7		
76		THC	—	299.4	299.4	—	286.2	286.2	—	272.1	272.1	—	256.9	256.9	—	240.7	240.7		
		SHC	—	115.3	152.9	—	110.9	148.2	—	106.3	143.3	—	101.3	138.0	—	96.1	132.6		
8000 Cfm		EAT (wb)	58	THC	235.3	235.3	266.2	226.8	226.8	256.5	217.5	217.5	246.0	207.4	207.4	234.5	196.3	196.3	222.0
				SHC	204.5	235.3	266.2	197.1	226.8	256.5	189.0	217.5	246.0	180.2	207.4	234.5	170.6	196.3	222.0
	62		THC	239.7	239.7	268.1	229.4	229.4	262.0	219.0	219.0	253.3	208.3	208.3	241.9	196.7	196.7	231.0	
			SHC	190.7	229.4	268.1	185.4	223.7	262.0	178.6	215.9	253.3	170.4	206.2	241.9	162.3	196.7	231.0	
	67		THC	261.3	261.3	261.3	249.6	249.6	249.6	237.1	237.1	237.1	223.6	223.6	223.6	209.2	209.2	210.6	
			SHC	152.3	191.8	231.2	147.7	187.1	226.6	142.9	182.2	221.6	137.7	177.0	216.3	132.2	171.4	210.6	
	72	THC	285.3	285.3	285.3	272.5	272.5	272.5	258.9	258.9	258.9	244.2	244.2	244.2	228.6	228.6	228.6		
		SHC	111.9	151.7	191.5	107.5	147.2	186.9	102.7	142.4	182.0	97.7	137.2	176.7	92.4	131.8	171.2		
	76	THC	—	305.4	305.4	—	291.6	291.6	—	276.8	276.8	—	261.2	261.2	—	244.4	244.4		
		SHC	—	119.4	161.0	—	114.9	156.2	—	110.1	151.2	—	105.1	146.0	—	99.8	140.4		
	9000 Cfm	EAT (wb)	58	THC	243.5	243.5	275.4	234.5	234.5	265.2	224.6	224.6	254.0	213.9	213.9	241.9	202.3	202.3	228.8
				SHC	211.6	243.5	275.4	203.8	234.5	265.2	195.2	224.6	254.0	185.9	213.9	241.9	175.8	202.3	228.8
62			THC	245.4	245.4	282.9	235.4	235.4	274.6	225.0	225.0	264.3	214.4	214.4	251.7	202.5	202.5	237.8	
			SHC	199.7	241.3	282.9	193.2	233.9	274.6	185.6	224.9	264.3	176.8	214.3	251.7	167.1	202.5	237.8	
67			THC	265.6	265.6	265.6	253.6	253.6	253.6	240.7	240.7	240.7	226.8	226.8	231.8	212.0	212.0	225.8	
			SHC	159.6	203.3	247.1	154.9	198.6	242.3	150.0	193.6	237.3	144.7	188.3	231.8	139.0	182.4	225.8	
72		THC	289.9	289.9	289.9	276.7	276.7	276.7	262.6	262.6	262.6	247.5	247.5	247.5	231.4	231.4	231.4		
		SHC	114.9	159.0	203.0	110.4	154.4	198.3	105.6	149.5	193.3	100.5	144.2	188.0	95.2	138.7	182.3		
76		THC	—	310.1	310.1	—	295.8	295.8	—	280.6	280.6	—	264.4	264.4	—	247.3	247.3		
		SHC	—	123.2	168.9	—	118.6	164.1	—	113.8	159.0	—	108.7	153.6	—	103.4	147.9		
10000 Cfm		EAT (wb)	58	THC	250.4	250.4	283.2	240.9	240.9	272.5	230.7	230.7	260.9	219.5	219.5	248.2	207.3	207.3	234.5
				SHC	217.7	250.4	283.2	209.4	240.9	272.5	200.5	230.7	260.9	190.7	219.5	248.2	180.2	207.3	234.5
	62		THC	250.8	250.8	294.6	241.1	241.1	283.3	231.1	231.1	271.4	219.6	219.6	258.0	207.5	207.5	243.7	
			SHC	207.0	250.8	294.6	199.0	241.1	283.3	190.7	231.1	271.4	181.2	219.6	258.0	171.2	207.5	243.7	
	67		THC	269.2	269.2	269.2	256.8	256.8	257.6	243.5	243.5	252.3	229.4	229.4	246.4	214.3	214.3	240.0	
			SHC	166.6	214.5	262.5	161.9	209.7	257.6	156.8	204.5	252.3	151.3	198.9	246.4	145.5	192.8	240.0	
	72	THC	293.7	293.7	293.7	280.1	280.1	280.1	265.6	265.6	265.6	250.2	250.2	250.2	233.7	233.7	233.7		
		SHC	117.8	166.0	214.2	113.2	161.3	209.3	108.3	156.3	204.3	103.2	151.0	198.8	97.8	145.4	193.1		
	76	THC	—	313.9	313.9	—	299.3	299.3	—	283.7	283.7	—	267.1	267.1	—	249.6	249.6		
		SHC	—	126.8	176.5	—	122.2	171.6	—	117.3	166.5	—	112.1	161.0	—	106.7	155.1		

LEGEND

- Do Not Operate
- Cfm — Cubic Feet Per Minute (Supply Air)
- EAT (db) — Entering Air Temperature (Dry Bulb)
- EAT (wb) — Entering Air Temperature (Wet Bulb)
- SHC — Sensible Heat Capacity (1000 Btuh) Gross

NOTE: See Minimum-Maximum Airflow Ratings table on page 5. Do not operate outside these limits.

50HC*D28 — 24 TON — COOLING CAPACITIES

50HC*D28				AMBIENT TEMPERATURE (F)															
				85			95			105			115			125			
				EAT (db)			EAT (db)			EAT (db)			EAT (db)			EAT (db)			
				75	80	85	75	80	85	75	80	85	75	80	85	75	80	85	
7500 Cfm	EAT (wb)	58	THC	264.4	264.4	298.9	254.6	254.6	287.9	244.1	244.1	276.0	232.7	232.7	263.1	220.3	220.3	249.1	
			SHC	229.9	264.4	298.9	221.4	254.6	287.9	212.2	244.1	276.0	202.3	232.7	263.1	191.5	220.3	249.1	
		62	THC	278.7	278.7	282.4	266.3	266.3	276.4	252.8	252.8	269.8	238.5	238.5	262.4	223.9	223.9	251.3	
			SHC	206.8	244.6	282.4	200.9	238.7	276.4	194.6	232.2	269.8	187.7	225.0	262.4	178.7	215.0	251.3	
		67	THC	305.3	305.3	305.3	291.9	291.9	291.9	277.3	277.3	277.3	261.5	261.5	261.5	244.5	244.5	244.5	
			SHC	169.0	207.0	245.0	163.4	201.4	239.4	157.4	195.3	233.3	151.0	188.9	226.8	144.2	182.1	219.9	
	72	THC	334.0	334.0	334.0	319.4	319.4	319.4	303.6	303.6	303.6	286.5	286.5	286.5	268.1	268.1	268.1		
		SHC	129.9	168.5	207.1	124.5	163.0	201.5	118.7	157.1	195.5	112.5	150.8	189.2	106.0	144.2	182.3		
	76	THC	—	358.2	358.2	—	342.4	342.4	—	325.4	325.4	—	307.1	307.1	—	287.4	287.4		
		SHC	—	137.0	178.2	—	131.7	172.9	—	126.0	166.9	—	119.9	160.4	—	113.4	153.4		
	8750 Cfm	EAT (wb)	58	THC	278.2	278.2	314.5	267.8	267.8	302.8	256.5	256.5	289.9	244.2	244.2	276.1	230.8	230.8	261.0
				SHC	241.9	278.2	314.5	232.8	267.8	302.8	223.0	256.5	289.9	212.3	244.2	276.1	200.7	230.8	261.0
62			THC	287.2	287.2	308.3	274.3	274.3	301.5	260.8	260.8	291.7	247.0	247.0	280.9	232.0	232.0	269.1	
			SHC	222.1	265.2	308.3	215.7	258.6	301.5	207.7	249.7	291.7	199.0	240.0	280.9	189.7	229.4	269.1	
67			THC	314.0	314.0	314.0	299.8	299.8	299.8	284.4	284.4	284.4	267.8	267.8	267.8	250.0	250.0	250.0	
			SHC	179.1	222.7	266.4	173.3	216.9	260.6	167.2	210.8	254.3	160.7	204.2	247.7	153.7	197.2	240.6	
72		THC	343.0	343.0	343.0	327.7	327.7	327.7	311.1	311.1	311.1	293.1	293.1	293.1	273.8	273.8	273.8		
		SHC	134.3	178.5	222.6	128.8	172.9	216.9	122.9	166.9	210.8	116.6	160.4	204.3	109.9	153.6	197.3		
76		THC	—	367.3	367.3	—	350.8	350.8	—	333.0	333.0	—	313.8	313.8	—	293.2	293.2		
		SHC	—	142.6	189.4	—	137.1	183.5	—	131.2	177.3	—	125.0	170.7	—	118.4	163.7		
10000 Cfm		EAT (wb)	58	THC	289.7	289.7	327.5	278.7	278.7	315.0	266.6	266.6	301.4	253.6	253.6	286.7	239.4	239.4	270.7
				SHC	251.9	289.7	327.5	242.3	278.7	315.0	231.8	266.6	301.4	220.5	253.6	286.7	208.2	239.4	270.7
	62		THC	294.6	294.6	329.6	282.2	282.2	319.7	268.7	268.7	309.1	254.1	254.1	298.4	239.7	239.7	281.4	
			SHC	234.7	282.1	329.6	226.8	273.3	319.7	218.4	263.7	309.1	209.7	254.1	298.4	197.9	239.7	281.4	
	67		THC	320.6	320.6	320.6	305.9	305.9	305.9	289.9	289.9	289.9	272.7	272.7	272.7	254.3	254.3	260.3	
			SHC	188.6	237.7	286.8	182.7	231.8	280.9	176.5	225.5	274.5	169.8	218.8	267.7	162.8	211.5	260.3	
	72	THC	350.0	350.0	350.0	334.0	334.0	334.0	316.8	316.8	316.8	298.2	298.2	298.2	278.3	278.3	278.3		
		SHC	138.4	187.9	237.5	132.8	182.2	231.7	126.8	176.1	225.5	120.4	169.6	218.8	113.6	162.6	211.7		
	76	THC	—	374.4	374.4	—	357.3	357.3	—	338.7	338.7	—	318.9	318.9	—	297.5	297.5		
		SHC	—	147.7	199.5	—	142.1	193.7	—	136.1	187.4	—	129.7	180.6	—	123.0	173.5		
	11250 Cfm	EAT (wb)	58	THC	299.4	299.4	338.4	287.8	287.8	325.4	275.2	275.2	311.1	261.4	261.4	295.6	246.6	246.6	278.8
				SHC	260.3	299.4	338.4	250.2	287.8	325.4	239.2	275.2	311.1	227.3	261.4	295.6	214.4	246.6	278.8
62			THC	302.2	302.2	346.0	289.3	289.3	335.7	275.5	275.5	323.5	262.1	262.1	307.7	246.8	246.8	289.8	
			SHC	244.8	295.4	346.0	236.7	286.2	335.7	227.5	275.5	323.5	216.4	262.1	307.7	203.8	246.8	289.8	
67			THC	325.9	325.9	325.9	310.7	310.7	310.7	294.2	294.2	294.2	276.6	276.6	286.7	257.7	257.7	278.9	
			SHC	197.6	252.1	306.5	191.7	246.1	300.4	185.3	239.6	293.9	178.5	232.6	286.7	171.2	225.1	278.9	
72		THC	355.5	355.5	355.5	339.1	339.1	339.1	321.3	321.3	321.3	302.2	302.2	302.2	281.8	281.8	281.8		
		SHC	142.1	197.0	251.8	136.4	191.2	245.9	130.4	185.0	239.6	123.9	178.3	232.8	117.1	171.3	225.5		
76		THC	—	380.0	380.0	—	362.4	362.4	—	343.3	343.3	—	322.8	322.8	—	300.9	300.9		
		SHC	—	152.4	209.4	—	146.8	203.4	—	140.7	197.0	—	134.2	190.2	—	127.3	182.8		
12500 Cfm		EAT (wb)	58	THC	307.7	307.7	347.9	295.7	295.7	334.2	282.5	282.5	319.3	268.2	268.2	303.2	252.7	252.7	285.7
				SHC	267.6	307.7	347.9	257.1	295.7	334.2	245.6	282.5	319.3	233.2	268.2	303.2	219.7	252.7	285.7
	62		THC	308.4	308.4	362.2	295.9	295.9	347.4	283.1	283.1	332.4	268.4	268.4	315.2	252.8	252.8	296.9	
			SHC	254.6	308.4	362.2	244.4	295.9	347.4	233.8	283.1	332.4	221.7	268.4	315.2	208.8	252.8	296.9	
	67		THC	330.2	330.2	330.2	314.6	314.6	319.2	297.8	297.8	312.3	279.8	279.8	304.7	260.6	260.6	295.9	
			SHC	206.3	265.9	325.5	200.3	259.7	319.2	193.8	253.1	312.3	186.7	245.7	304.7	179.0	237.4	295.9	
	72	THC	360.1	360.1	360.1	343.2	343.2	343.2	325.0	325.0	325.0	305.4	305.4	305.4	284.6	284.6	284.6		
		SHC	145.7	205.7	265.7	139.9	199.8	259.7	133.8	193.5	253.3	127.3	186.8	246.3	120.4	179.7	238.9		
	76	THC	—	384.6	384.6	—	366.5	366.5	—	346.9	346.9	—	325.9	325.9	—	303.5	303.5		
		SHC	—	157.0	218.9	—	151.2	212.9	—	145.1	206.3	—	138.5	199.3	—	131.5	191.7		

LEGEND

- Do Not Operate
- Cfm — Cubic Feet Per Minute (Supply Air)
- EAT (db) — Entering Air Temperature (Dry Bulb)
- EAT (wb) — Entering Air Temperature (Wet Bulb)
- SHC — Sensible Heat Capacity (1000 Btuh) Gross

NOTE: See Minimum-Maximum Airflow Ratings table on page 5. Do not operate outside these limits.



50HC*E17 COOLING CAPACITIES, SUBCOOLING MODE

TEMP (F) AIR ENT CONDENSER (Edb)		AIR ENTERING EVAPORATOR - CFM								
		4,500			6,000			7,500		
		Air Entering Evaporator - Ewb (F)								
		72	67	62	72	67	62	72	67	62
75	TC	202.90	184.60	166.20	213.70	194.60	175.40	222.30	202.50	182.70
	SHC	91.90	112.40	132.90	106.10	126.40	146.80	117.50	137.70	158.00
	kW	10.19	10.12	9.78	10.51	10.19	9.95	10.61	10.36	10.12
85	TC	189.80	171.80	153.80	201.00	182.20	163.30	209.90	190.40	170.80
	SHC	75.90	101.00	126.20	91.20	116.30	141.30	103.40	128.40	153.50
	kW	11.57	11.49	11.15	11.88	11.56	11.32	11.98	11.73	11.49
95	TC	176.70	159.10	141.40	188.30	169.70	151.20	197.50	178.20	159.00
	SHC	59.80	89.70	119.60	76.20	106.10	135.90	89.40	119.20	149.00
	kW	12.87	12.81	12.47	13.20	12.88	12.64	13.30	13.05	12.81
105	TC	163.60	146.30	129.00	175.60	157.30	139.10	185.10	166.10	147.10
	SHC	43.80	78.40	112.90	61.30	95.90	130.40	75.30	109.90	144.40
	kW	14.05	14.00	13.65	14.39	14.07	13.82	14.40	14.24	14.00
115	TC	150.50	133.50	116.50	162.90	144.90	127.00	172.70	154.00	135.30
	SHC	27.70	67.00	106.30	46.40	85.70	125.00	61.30	100.60	133.40
	kW	15.44	15.36	15.02	15.75	15.43	15.19	15.85	15.60	15.36
125	TC	137.40	120.80	104.10	150.20	132.50	114.9	160.30	141.90	123.50
	SHC	11.70	55.70	99.60	31.40	75.50	112.9	47.30	91.30	123.00
	kW	16.77	16.71	16.37	17.10	16.78	16.54	17.20	16.95	16.71

50HC*E17 COOLING CAPACITIES, HOT GAS REHEAT MODE

TEMP (F) AIR ENT CONDENSER (Edb)		AIR ENTERING EVAPORATOR - Ewb (F)								
		75 Dry Bulb 62.5 Wet Bulb (50% Relative)			75 Dry Bulb 64 Wet Bulb (56% Relative)			75 Dry Bulb 65.3 Wet Bulb (60% Relative)		
		Air Entering Evaporator - Cfm								
		4,500	6,000	7,500	4,500	6,000	7,500	4,500	6,000	7,500
80	TC	64.50	71.00	73.30	68.40	74.50	77.30	71.20	79.70	80.60
	SHC	12.60	24.90	36.80	6.80	13.70	23.90	-0.80	5.50	13.80
	kW	10.10	10.26	10.42	10.18	10.40	10.56	10.33	10.47	10.67
75	TC	66.60	73.10	75.60	70.50	76.60	79.50	73.20	80.80	82.90
	SHC	14.30	26.70	38.50	8.10	14.90	25.70	0.70	7.00	15.00
	kW	10.05	10.22	10.36	10.14	10.36	10.52	10.28	10.43	10.62
70	TC	68.70	75.10	77.40	72.50	78.60	81.40	75.20	82.80	84.90
	SHC	15.40	27.80	40.00	9.50	16.20	26.80	2.10	8.40	16.30
	kW	10.00	10.18	10.33	10.10	10.31	10.47	10.23	10.40	10.58
60	TC	72.80	79.30	81.60	76.70	82.80	85.70	79.40	86.90	88.80
	SHC	19.00	31.10	43.20	12.70	19.90	30.10	5.30	11.60	20.00
	kW	9.92	10.09	10.24	10.01	10.22	10.37	10.14	10.31	10.49
50	TC	76.80	83.40	85.70	80.80	86.90	89.70	83.50	90.90	92.80
	SHC	21.70	34.20	46.20	15.80	22.70	33.20	8.40	14.70	22.80
	kW	9.83	10.00	10.15	9.92	10.13	10.29	10.05	10.21	10.39
40	TC	80.90	87.30	89.60	84.90	90.80	93.60	87.40	94.80	96.70
	SHC	24.90	37.10	49.30	19.00	26.00	36.10	11.60	17.90	26.20
	kW	9.74	9.91	10.06	9.83	10.04	10.20	9.96	10.12	10.30

LEGEND

- Edb — Entering Dry Bulb
- Ewb — Entering Wet Bulb
- kW — Kilowatts
- SHC — Sensible Heat Capacity
- TC — Total Capacity



50HC*E20 COOLING CAPACITIES, SUBCOOLING MODE

TEMP (F) AIR ENT CONDENSER (Edb)		AIR ENTERING EVAPORATOR - CFM								
		5250			7000			8750		
		Air Entering Evaporator - Ewb (F)								
		72	67	62	72	67	62	72	67	62
75	TC	232.0	211.3	190.6	242.4	221.0	199.7	250.7	228.9	207.0
	SHC	110.9	133.7	156.4	127.6	150.3	173.0	141.1	163.7	186.4
	kW	12.45	12.16	11.81	12.74	12.41	12.02	12.93	12.51	12.18
85	TC	215.9	195.7	175.5	226.0	205.2	184.4	234.2	212.8	191.5
	SHC	90.6	118.8	147.0	108.4	136.6	164.9	122.7	151.0	179.2
	kW	13.48	13.20	12.88	13.77	13.47	13.07	13.96	13.58	13.23
95	TC	199.7	180.0	160.3	209.7	189.4	169.1	217.6	196.8	176.1
	SHC	70.3	104.0	137.7	89.2	123.0	156.7	104.4	138.2	172.1
	kW	14.60	14.25	13.94	14.89	14.51	14.15	15.08	14.63	14.31
105	TC	183.6	164.5	145.2	193.3	173.5	153.8	201.0	180.8	160.6
	SHC	50.0	89.1	128.3	70.0	109.3	148.6	86.0	125.5	158.6
	kW	15.64	15.36	15.01	15.93	15.60	15.21	16.12	15.72	15.37
115	TC	167.5	148.8	130.1	176.9	157.7	138.5	184.5	164.8	145.1
	SHC	29.7	74.3	118.9	50.7	95.6	138.1	67.7	112.7	145.1
	kW	16.70	16.38	15.82	16.98	16.63	16.03	17.17	16.75	16.19
125	TC	151.4	133.2	115.0	160.6	141.9	123.1	167.9	148.8	129.7
	SHC	9.4	59.5	109.6	31.5	81.9	123.0	49.3	100.0	129.7
	kW	17.71	17.39	17.09	18.01	17.65	17.30	18.20	17.76	17.46

50HC*E20 COOLING CAPACITIES, HOT GAS REHEAT MODE

TEMP (F) AIR ENT CONDENSER (Edb)		AIR ENTERING EVAPORATOR - Ewb (F)								
		75 Dry Bulb 62.5 Wet Bulb (50% Relative)			75 Dry Bulb 64 Wet Bulb (56% Relative)			75 Dry Bulb 65.3 Wet Bulb (60% Relative)		
		Air Entering Evaporator - Cfm								
		5,250	7,000	8,750	5,250	7,000	8,750	5,250	7,000	8,750
80	TC	67.80	71.30	74.10	70.50	74.80	79.80	73.30	78.20	82.40
	SHC	9.00	26.50	41.70	2.20	13.20	26.90	-5.20	2.90	13.80
	kW	11.65	11.75	11.87	11.82	11.90	11.98	11.93	12.10	12.19
75	TC	72.50	76.00	78.80	75.00	79.20	84.30	78.00	83.00	86.90
	SHC	13.40	30.90	46.10	6.50	18.00	31.30	-2.10	7.20	17.90
	kW	11.44	11.54	11.66	11.61	11.68	11.75	11.70	11.86	11.95
70	TC	77.10	80.60	83.40	79.50	83.90	88.90	82.40	87.30	91.10
	SHC	17.60	34.70	49.90	10.80	22.20	35.10	3.20	11.50	22.20
	kW	11.22	11.33	11.45	11.40	11.46	11.54	11.49	11.64	11.75
60	TC	86.30	89.90	92.70	88.80	93.20	98.20	91.70	96.60	100.50
	SHC	26.20	43.20	58.40	19.40	30.80	43.60	11.60	20.10	30.70
	kW	10.76	10.86	10.98	10.93	11.00	11.07	11.03	11.18	11.28
50	TC	95.50	99.10	101.90	98.00	102.40	107.40	101.00	106.00	109.80
	SHC	34.80	51.80	67.00	28.00	39.40	52.20	20.10	28.70	39.40
	kW	10.33	10.43	10.55	10.50	10.52	10.63	10.59	10.74	10.85
40	TC	104.80	108.40	111.20	107.30	111.70	116.60	110.30	115.30	119.10
	SHC	43.40	60.40	75.60	36.60	48.00	60.80	28.80	37.30	47.90
	kW	9.87	9.97	10.09	10.04	10.11	10.18	10.14	10.28	10.40

LEGEND

- Edb** — Entering Dry Bulb
- Ewb** — Entering Wet Bulb
- kW** — Kilowatts
- SHC** — Sensible Heat Capacity
- TC** — Total Capacity

50HC*E24 COOLING CAPACITIES, SUBCOOLING MODE

TEMP (F) AIR ENT CONDENSER (Edb)		AIR ENTERING EVAPORATOR - CFM								
		6,000			8,000			10,000		
		Air Entering Evaporator - Ewb (F)								
		72	67	62	72	67	62	72	67	62
75	TC	281.6	256.5	231.3	293.1	267.0	240.9	302.3	275.4	248.6
	SHC	114.7	141.0	167.4	140.6	166.6	192.6	161.6	187.3	212.9
	kW	13.52	13.25	12.95	13.82	13.46	13.21	13.97	13.60	13.31
85	TC	261.3	236.9	212.4	272.1	247.7	221.3	280.7	254.6	228.5
	SHC	90.9	123.5	156.1	118.8	151.1	183.3	141.4	173.4	205.4
	kW	14.95	14.68	14.48	15.25	14.89	14.64	15.40	15.03	14.74
95	TC	241.1	217.2	193.4	251.1	226.4	201.7	259.2	233.8	208.4
	SHC	67.2	106.0	144.8	97.1	120.1	174.1	121.2	159.5	197.8
	kW	16.52	16.25	15.95	16.82	16.46	16.21	16.97	16.60	16.31
105	TC	220.8	197.5	174.4	230.2	206.2	182.2	237.7	213.0	188.4
	SHC	43.4	88.4	133.5	75.3	120.1	164.9	101.0	145.7	178.9
	kW	18.09	17.82	17.52	18.39	18.03	17.78	18.54	18.17	17.88
115	TC	200.5	178.0	155.5	209.2	185.9	162.6	216.2	192.2	168.7
	SHC	19.7	70.9	122.2	53.5	104.6	155.7	80.9	131.8	161.2
	kW	19.65	19.38	19.08	19.95	19.59	19.34	20.10	19.73	19.44
125	TC	180.2	158.4	136.5	188.2	165.6	143.0	194.7	171.4	148.2
	SHC	-4.1	53.4	110.8	31.7	89.1	142.2	60.7	118.0	145.1
	kW	20.59	20.32	20.02	20.89	20.53	20.28	21.04	20.67	20.38

50HC*E24 COOLING CAPACITIES, HOT GAS REHEAT MODE

TEMP (F) AIR ENT CONDENSER (Edb)		AIR ENTERING EVAPORATOR - Ewb (F)								
		75 Dry Bulb 62.5 Wet Bulb (50% Relative)			75 Dry Bulb 64 Wet Bulb (56% Relative)			75 Dry Bulb 65.3 Wet Bulb (60% Relative)		
		Air Entering Evaporator - Cfm								
		6,000	8,000	10,000	6,000	8,000	10,000	6,000	8,000	10,000
80	TC	115.20	123.30	130.60	120.40	129.30	138.20	122.80	135.00	143.70
	SHC	40.80	58.30	76.10	32.30	45.50	60.40	20.10	34.30	48.00
	kW	13.24	13.32	13.39	13.43	13.57	13.65	13.49	13.68	13.74
75	TC	119.80	128.60	135.90	125.50	135.30	143.20	128.00	139.50	148.40
	SHC	45.60	62.80	82.10	37.00	49.80	65.20	24.30	38.70	52.60
	kW	13.05	13.10	13.17	13.21	13.35	13.43	13.27	13.46	13.52
70	TC	122.50	133.10	140.20	129.80	140.70	147.60	132.40	144.40	153.20
	SHC	49.80	76.00	86.10	41.10	54.30	69.20	28.80	41.40	56.80
	kW	12.80	12.87	12.94	12.98	13.12	13.20	13.04	13.23	13.29
60	TC	133.80	142.50	149.60	139.30	150.40	157.40	141.50	154.20	163.00
	SHC	58.60	76.00	95.00	50.20	63.50	78.10	37.80	52.10	65.90
	kW	12.34	12.42	12.49	12.53	12.67	12.75	12.59	12.78	12.84
50	TC	143.50	151.80	159.30	149.00	160.00	167.00	151.30	163.60	172.50
	SHC	67.70	84.80	103.80	59.10	72.40	87.00	46.70	61.00	74.90
	kW	11.88	11.95	12.03	12.07	12.21	12.29	12.13	12.32	12.38
40	TC	153.20	161.30	168.70	158.60	169.20	176.60	160.80	173.10	182.00
	SHC	76.50	93.60	111.60	68.00	81.50	95.80	55.80	69.80	84.00
	kW	11.42	11.49	11.56	11.60	11.74	11.82	11.66	11.85	11.91

LEGEND

- Edb** — Entering Dry Bulb
- Ewb** — Entering Wet Bulb
- kW** — Kilowatts
- SHC** — Sensible Heat Capacity
- TC** — Total Capacity



50HC*E28 COOLING CAPACITIES, SUBCOOLING MODE

TEMP (F) AIR ENT CONDENSER (Edb)		AIR ENTERING EVAPORATOR - CFM								
		7,500			10,000			12,500		
		Air Entering Evaporator - Ewb (F)								
		72	67	62	72	67	62	72	67	62
75	TC	351.3	319.5	287.8	370.4	337.3	304.1	385.8	351.5	317.2
	SHC	166.5	199.4	232.3	191.2	245.6	258.5	211.4	245.6	279.9
	kW	16.75	16.55	15.20	17.30	16.75	15.85	17.80	17.50	16.50
85	TC	327.5	296.4	265.3	346.1	313.6	281.2	361.1	327.5	294.0
	SHC	137.4	178.2	219.0	162.6	204.5	246.4	183.3	226.0	268.7
	kW	18.65	18.45	17.25	19.20	18.65	17.80	19.45	19.15	18.15
95	TC	303.7	273.3	242.9	321.8	290.0	258.3	336.4	303.5	270.7
	SHC	108.2	157.0	205.8	134.0	184.1	234.3	155.1	206.4	257.6
	kW	20.60	20.40	19.34	21.15	20.60	19.95	21.60	21.30	20.30
105	TC	279.9	250.2	220.4	297.5	266.4	235.3	311.7	279.5	247.4
	SHC	79.0	135.8	192.5	105.4	163.8	222.2	127.1	186.7	246.4
	kW	22.85	22.65	21.45	23.40	22.85	22.05	23.70	23.40	22.40
115	TC	256.2	227.1	198.0	273.2	242.8	212.4	287.0	255.5	224.1
	SHC	49.9	114.5	179.2	76.8	143.4	210.1	98.9	167.1	223.8
	kW	25.05	24.85	23.65	25.60	25.05	24.25	25.90	25.60	24.60
125	TC	232.4	203.9	175.5	248.9	219.2	189.5	262.3	231.5	200.8
	SHC	20.7	93.3	166.0	48.2	123.1	188.9	70.8	147.4	200.8
	kW	27.25	27.05	25.80	27.80	27.25	26.50	28.15	27.85	26.85

50HC*E28 COOLING CAPACITIES, HOT GAS REHEAT MODE

TEMP (F) AIR ENT CONDENSER (Edb)		AIR ENTERING EVAPORATOR - Ewb (F)								
		75 Dry Bulb 62.5 Wet Bulb (50% Relative)			75 Dry Bulb 64 Wet Bulb (56% Relative)			75 Dry Bulb 65.3 Wet Bulb (60% Relative)		
		Air Entering Evaporator - Cfm								
		7,500	10,000	12,500	7,500	10,000	12,500	7,500	10,000	12,500
80	TC	124.40	133.90	139.00	132.00	142.10	145.10	135.60	149.10	151.50
	SHC	37.60	60.70	82.20	27.80	45.40	65.80	17.50	34.20	50.10
	kW	15.83	15.90	16.00	15.97	16.13	16.16	16.11	16.31	16.38
75	TC	129.00	138.50	144.60	136.60	147.60	150.10	140.60	154.00	156.30
	SHC	47.10	70.60	92.10	37.30	55.30	75.70	27.00	43.70	60.00
	kW	15.77	15.83	15.94	15.91	16.07	16.10	16.05	16.25	16.32
70	TC	133.60	143.10	149.20	141.20	152.30	154.80	145.30	158.80	161.10
	SHC	57.30	80.70	102.20	47.50	65.40	85.80	37.20	53.90	70.10
	kW	15.68	15.75	15.86	15.83	16.00	16.04	15.88	16.08	16.15
60	TC	142.80	158.40	158.40	150.40	161.40	163.90	153.90	167.40	169.70
	SHC	76.50	121.40	121.40	66.70	84.60	105.00	56.40	73.10	89.30
	kW	15.54	15.60	15.71	15.68	15.84	15.87	15.82	16.02	16.09
50	TC	151.80	161.30	167.40	159.40	170.50	173.20	162.80	176.20	178.80
	SHC	94.10	117.50	139.00	84.30	102.20	122.60	74.00	90.70	106.90
	kW	15.40	15.47	15.58	15.54	15.68	15.71	15.66	15.86	15.93
40	TC	161.20	170.70	176.80	168.80	179.80	182.50	172.20	185.70	188.20
	SHC	114.10	137.60	159.10	104.30	122.30	142.70	94.00	110.70	127.00
	kW	15.24	15.31	15.42	15.39	15.55	15.58	15.53	15.73	15.80

LEGEND

- Edb — Entering Dry Bulb
- Ewb — Entering Wet Bulb
- kW — Kilowatts
- SHC — Sensible Heat Capacity
- TC — Total Capacity

ECONOMIZER, BAROMETRIC RELIEF AND POWER EXHAUST PERFORMANCE — VERTICAL APPLICATIONS

PRESSURE DROP ACROSS ELECTRIC HEAT EXCHANGER

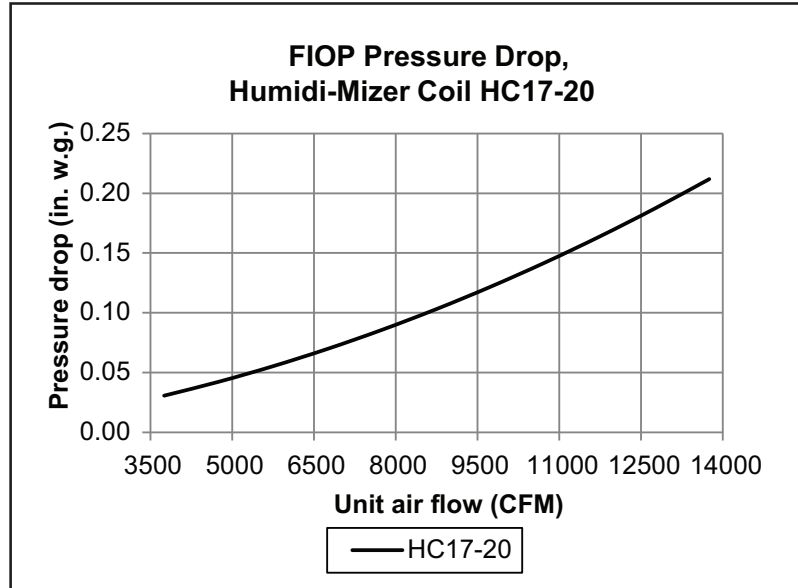

15-17.5 TONS

CFM	3750	4750	5750	6750	7750	8750	9750	10750	11750	12750	13750
PRESSURE DROP (in. wg)	0.03	0.04	0.06	0.07	0.09	0.10	0.12	0.14	0.16	0.19	0.21

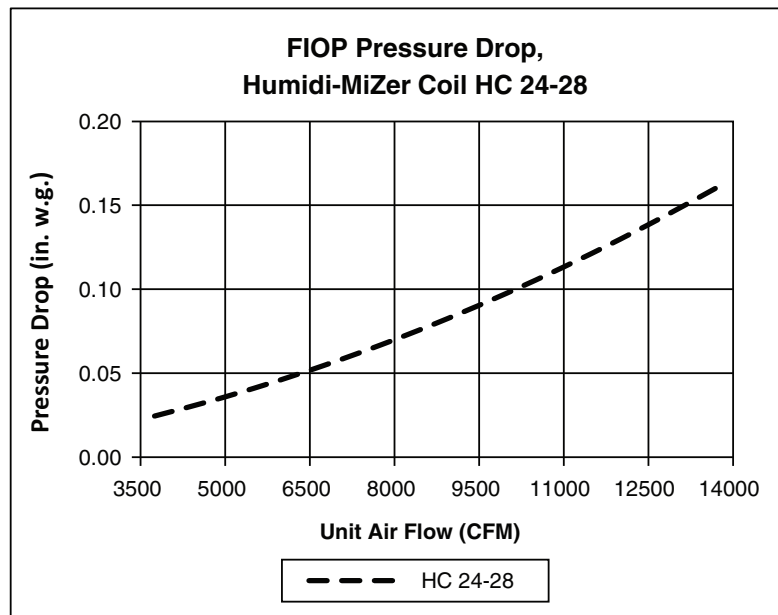

20-25 TONS

CFM	3750	4750	5750	6750	7750	8750	9750	10750	11750	12750	13750
PRESSURE DROP (in. wg)	0.02	0.03	0.04	0.05	0.07	0.08	0.09	0.11	0.13	0.14	0.16

ECONOMIZER, BAROMETRIC RELIEF AND POWER EXHAUST PERFORMANCE

PRESSURE DROP THROUGH VERTICAL ECONOMIZERS

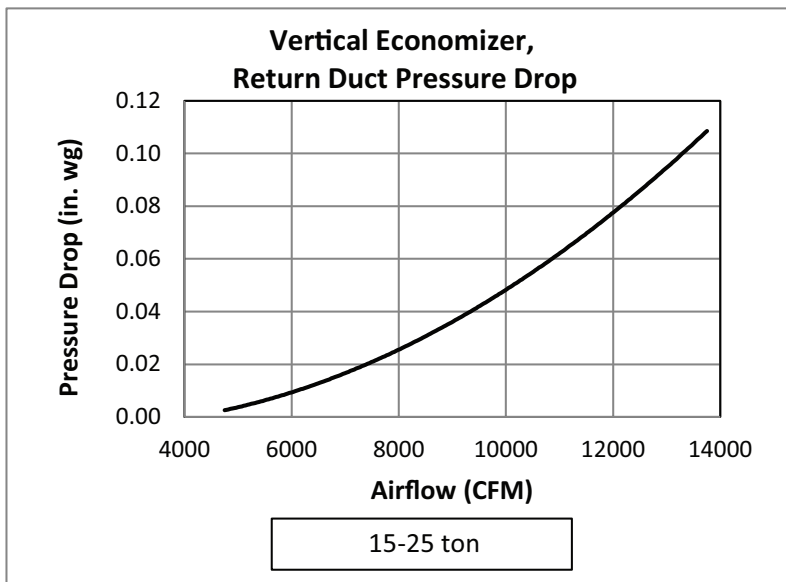

15-25 TONS

CFM	4750	5750	6750	7750	8750	9750	10750	11750	12750	13750
PRESSURE DROP (in. wg)	0.00	0.01	0.01	0.02	0.03	0.05	0.06	0.07	0.09	0.11

PRESSURE DROP ACROSS ELECTRIC HEAT EXCHANGER, ALL VOLTAGES

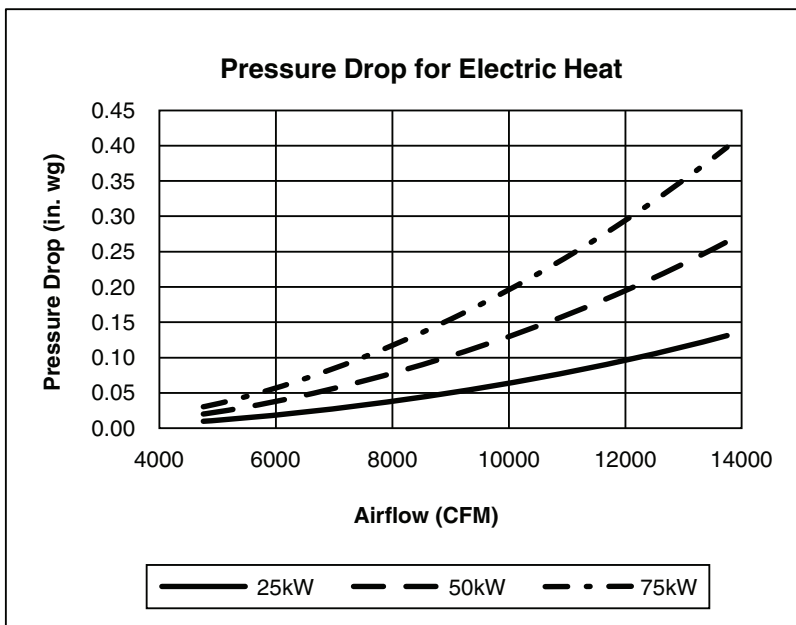

15-25 TONS

CFM	4750	5750	6750	7750	8750	9750	10750	11750	12750	13750
25kW	0.01	0.02	0.03	0.04	0.05	0.06	0.08	0.09	0.11	0.13
50kW	0.02	0.03	0.05	0.07	0.10	0.12	0.15	0.19	0.22	0.26
75kW	0.03	0.05	0.08	0.11	0.14	0.18	0.23	0.28	0.34	0.40

ECONOMIZER, BAROMETRIC RELIEF AND POWER EXHAUST PERFORMANCE (cont)

PRESSURE DROP THROUGH OUTSIDE AIR DAMPER

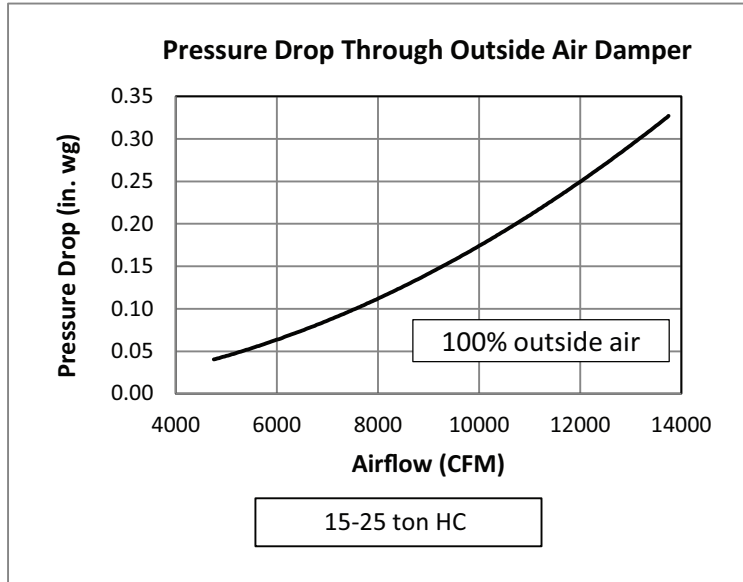

15-25 TONS

CFM	4750	5750	6750	7750	8750	9750	10750	11750	12750	13750
PRESSURE DROP (in. wg)	0.04	0.06	0.08	0.11	0.13	0.17	0.20	0.24	0.28	0.33

50HC UNITS WITH EnergyX® — POWER EXHAUST PERFORMANCE

15 TO 17.5 TON ERV EXHAUST FAN CURVES

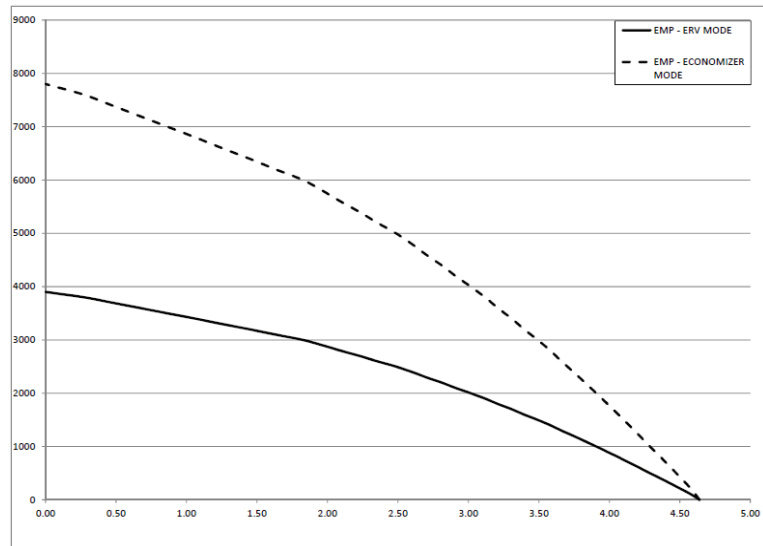

20 TO 25 TON ERV EXHAUST FAN CURVES

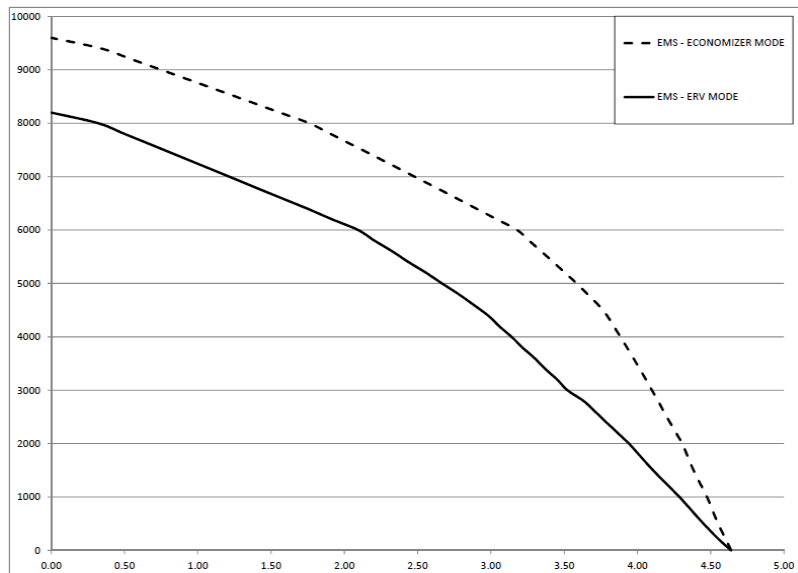

Performance data (cont)



STATIC PRESSURE ADDERS FOR ELECTRIC HEATERS (in. wg) — VERTICAL DUCT CONFIGURATION

15-25 TONS								
CFM	4500	5000	5500	6000	6500	7000	7500	8000
25kW	0.010	0.010	0.015	0.200	0.250	0.300	0.035	0.040
50kW	0.020	0.020	0.030	0.040	0.050	0.060	0.070	0.080
75kW	0.030	0.040	0.050	0.060	0.070	0.080	0.100	0.120

STATIC PRESSURE ADDERS FOR ELECTRIC HEATERS (in. wg) — VERTICAL DUCT CONFIGURATION (cont)

15-25 TONS									
CFM	8500	9000	9500	10000	10500	11000	11500	12000	12500
25kW	0.045	0.050	0.055	0.060	0.070	0.080	0.090	0.100	0.105
50kW	0.090	0.100	0.120	0.130	0.150	0.160	0.180	0.200	0.230
75kW	0.140	0.150	0.180	0.200	0.230	0.250	0.270	0.300	0.330

GENERAL FAN PERFORMANCE NOTES:

1. Interpolation is permissible. Do not extrapolate.
2. External static pressure is the static pressure difference between the return duct and the supply duct plus the static pressure caused by any FIOPs or accessories.
3. Tabular data accounts for pressure loss due to clean filters, unit casing, and wet coils. Factory options and accessories may add static pressure losses. Selection software is available, through your salesperson, to help you select the best motor/drive combination for your application.
4. The Fan Performance tables offer motor/drive recommendations. In cases when two motor/drive combinations would work, Carrier recommended the lower horsepower option.
5. For information on the electrical properties of Carrier motors, please see the Electrical information section of this book.
6. For more information on the performance limits of Carrier motors, see the application data section of this book. The EPACT (Energy Policy Act of 1992) regulates energy requirements for specific types of indoor fan motors. Motors regulated by EPACT include any general purpose, T-frame (three-digit, 143 and larger), single-speed, foot mounted, polyphase, squirrel cage induction motors of NEMA (National Electrical Manufacturers Association) design A and B, manufactured for use in the United States. Ranging from 1 to 200 Hp, these continuous-duty motors operate on 230 and 460 volt, 60 Hz power. If a motor does not fit into these specifications, the motor does not have to be replaced by an EPACT compliant energy-efficient motor. Variable-speed motors are exempt from EPACT compliance requirements.

50HC**17, 15 TON, VERTICAL SUPPLY/RETURN — FAN PERFORMANCE

CFM	Available External Static Pressure (in. wg)									
	0.2		0.4		0.6		0.8		1.0	
	RPM	BHP	RPM	BHP	RPM	BHP	RPM	BHP	RPM	BHP
4500	436	0.60	529	0.89	611	1.20	684	1.54	749	1.90
4900	458	0.72	546	1.02	625	1.36	696	1.72	760	2.09
5250	479	0.85	561	1.16	638	1.51	708	1.88	771	2.27
5650	503	1.01	580	1.33	654	1.70	721	2.09	784	2.50
6000	525	1.17	598	1.50	668	1.88	734	2.28	795	2.71
6400	551	1.38	619	1.72	686	2.11	750	2.53	810	2.97
6750	574	1.58	638	1.93	702	2.33	764	2.76	822	3.22
7150	601	1.84	661	2.20	722	2.61	781	3.06	838	3.53
7500	625	2.09	682	2.46	740	2.88	797	3.34	852	3.82

CFM	Available External Static Pressure (in. wg)									
	0.2		0.4		0.6		0.8		1.0	
	RPM	BHP	RPM	BHP	RPM	BHP	RPM	BHP	RPM	BHP
4500	808	2.27	864	2.66	916	3.06	965	3.48	1012	3.92
4900	819	2.48	874	2.89	926	3.31	975	3.74	1021	4.19
5250	829	2.68	884	3.10	935	3.53	983	3.98	1029	4.44
5650	841	2.92	895	3.36	946	3.81	994	4.28	1040	4.76
6000	852	3.15	906	3.61	956	4.08	1003	4.56	—	—
6400	865	3.43	918	3.91	968	4.40	1015	4.90	—	—
6750	878	3.70	929	4.19	979	4.69	—	—	—	—
7150	892	4.03	943	4.53	—	—	—	—	—	—
7500	905	4.33	955	4.86	—	—	—	—	—	—

NOTES:

1. **Boldface** indicates field-supplied drive is required.
2. *Italics* requires high static drive package with different motor pulley.

	Standard static 514-680 RPM, 2.9 BHP, max
	Medium static 679-865 RPM, 3.7 BHP max
	High static 826-1009 RPM, 4.9 BHP max



50HC**17, 15 TON, HORIZONTAL SUPPLY/RETURN — FAN PERFORMANCE

CFM	Available External Static Pressure (in. wg)									
	0.2		0.4		0.6		0.8		1.0	
	RPM	BHP	RPM	BHP	RPM	BHP	RPM	BHP	RPM	BHP
4500	472	1.04	549	1.51	616	2.03	676	2.59	731	3.19
4900	500	1.26	573	1.76	638	2.30	696	2.89	750	3.51
5250	525	1.48	595	2.00	658	2.57	715	3.18	767	3.82
5650	554	1.76	620	2.30	681	2.90	736	3.54	787	4.21
6000	580	2.04	643	2.61	702	3.22	756	3.88	806	4.58
6400	610	2.39	670	2.99	727	3.64	779	4.32	—	—
6750	636	2.74	695	3.36	749	4.03	800	4.74	—	—
7150	667	3.18	723	3.83	775	4.52	—	—	—	—
7500	694	3.60	748	4.28	—	—	—	—	—	—

CFM	Available External Static Pressure (in. wg)									
	1.2		1.4		1.6		1.8		2.0	
	RPM	BHP	RPM	BHP	RPM	BHP	RPM	BHP	RPM	BHP
4500	781	3.81	828	4.46	—	—	—	—	—	—
4900	799	4.16	845	4.84	—	—	—	—	—	—
5250	816	4.49	—	—	—	—	—	—	—	—
5650	—	—	—	—	—	—	—	—	—	—
6000	—	—	—	—	—	—	—	—	—	—
6400	—	—	—	—	—	—	—	—	—	—
6750	—	—	—	—	—	—	—	—	—	—
7150	—	—	—	—	—	—	—	—	—	—
7500	—	—	—	—	—	—	—	—	—	—

NOTES:

1. **Boldface** indicates field-supplied drive is required.
2. *Italics* requires high static drive package with different motor pulley.

-  Standard static 514-680 RPM, 2.9 BHP, max
-  Medium static 614-780 RPM, 3.7 BHP max
-  High static 746-912 RPM, 4.9 BHP max

50HC**20, 17.5 TON, VERTICAL SUPPLY/RETURN — FAN PERFORMANCE

CFM	Available External Static Pressure (in. wg)									
	0.2		0.4		0.6		0.8		1.0	
	RPM	BHP	RPM	BHP	RPM	BHP	RPM	BHP	RPM	BHP
5250	479	0.85	561	1.16	638	1.51	708	1.88	771	2.27
5700	506	1.03	582	1.35	656	1.72	723	2.11	785	2.53
6150	535	1.25	605	1.58	675	1.96	740	2.37	801	2.81
6550	561	1.46	627	1.81	693	2.20	756	2.63	815	3.08
7000	591	1.74	652	2.10	714	2.50	775	2.94	832	3.41
7450	622	2.05	679	2.42	737	2.84	795	3.30	850	3.78
7900	653	2.40	706	2.78	761	3.21	816	3.68	869	4.18
8300	681	2.75	731	3.14	783	3.58	836	4.06	887	4.57
8750	713	3.18	760	3.58	809	4.03	859	4.53	908	5.05

CFM	Available External Static Pressure (in. wg)									
	1.2		1.4		1.6		1.8		2.0	
	RPM	BHP	RPM	BHP	RPM	BHP	RPM	BHP	RPM	BHP
5250	829	2.68	884	3.10	935	3.53	983	3.98	1029	4.44
5700	843	2.95	897	3.40	947	3.85	995	4.32	1041	4.80
6150	857	3.26	910	3.72	960	4.19	1008	4.68	1053	5.18
6550	871	3.54	923	4.03	972	4.52	1019	5.03	1064	5.55
7000	886	3.90	938	4.40	987	4.92	1033	5.45	1077	5.98
7450	903	4.29	953	4.81	1001	5.34	1047	5.89	1091	6.45
7900	921	4.71	970	5.25	1017	5.81	1062	6.38	1105	6.96
8300	937	5.11	985	5.67	1031	6.25	<u>1076</u>	<u>6.83</u>	1119	7.43
8750	956	5.61	1003	6.19	<u>1048</u>	<u>6.78</u>	1092	7.39	1134	8.01

NOTES:

1. **Boldface** indicates field-supplied drive is required.
2. *Italics* requires high static drive package with different motor pulley.
3. Underscored text indicates the operation point is covered by mid-static drive. Confirm Max BHP coverage based on unit voltage selected.

- Standard static 622-822 RPM, 3.7 BHP, max
- Medium static 713-879 RPM, 4.9 BHP max
- High static 882-1078 RPM, 208V (6.5 Max BHP) / 230V (6.9 Max BHP) / 460V (7.0 Max BHP) / 575V (8.3 Max BHP)
- Operation point covered by high static drive. Confirm Max BHP coverage based on unit voltage selected.

50HC**20, 17.5 TON, HORIZONTAL SUPPLY/RETURN — FAN PERFORMANCE

CFM	Available External Static Pressure (in. wg)									
	0.2		0.4		0.6		0.8		1.0	
	RPM	BHP	RPM	BHP	RPM	BHP	RPM	BHP	RPM	BHP
5250	525	1.48	595	2.00	658	2.57	715	3.18	767	3.82
5700	558	1.80	624	2.35	684	2.95	739	3.58	790	4.26
6150	591	2.16	654	2.74	711	3.37	764	4.04	814	4.75
6550	621	2.54	681	3.14	736	3.80	788	4.50	836	5.23
7000	656	3.01	712	3.65	765	4.33	<i>815</i>	<i>5.06</i>	862	5.82
7450	690	3.54	744	4.21	795	4.93	843	5.68	888	6.47
7900	726	4.14	777	4.84	<i>825</i>	<i>5.59</i>	872	6.37	916	7.19
8300	757	4.72	<i>806</i>	<i>5.45</i>	853	6.23	898	7.04	940	7.89
8750	793	5.45	840	6.21	885	7.02	928	7.86	—	—

CFM	Available External Static Pressure (in. wg)									
	1.2		1.4		1.6		1.8		2.0	
	RPM	BHP	RPM	BHP	RPM	BHP	RPM	BHP	RPM	BHP
5250	816	4.49	861	5.20	904	5.92	945	6.68	984	7.45
5700	838	4.96	882	5.70	925	6.46	965	7.24	1003	8.04
6150	861	5.48	904	6.25	946	7.04	986	7.85	—	—
6550	882	5.99	925	6.78	966	7.60	—	—	—	—
7000	906	6.61	948	7.43	988	8.28	—	—	—	—
7450	931	7.30	973	8.15	—	—	—	—	—	—
7900	958	8.05	—	—	—	—	—	—	—	—
8300	—	—	—	—	—	—	—	—	—	—
8750	—	—	—	—	—	—	—	—	—	—

NOTES:

- Boldface** indicates field-supplied drive is required.
- Italics* requires high static drive package with different motor pulley.

- Medium static 713-879 RPM, 4.9 BHP max
- High static 835-1021 RPM, 208V (6.5 Max BHP) / 230V (6.9 Max BHP) / 460V (7.0 Max BHP) / 575V (8.3 Max BHP)
- Operation point covered by high static drive. Confirm Max BHP coverage based on unit voltage selected.

Standard static 622-822 RPM, 3.7 BHP, max



50HC**24, 20 TON, VERTICAL SUPPLY/RETURN — FAN PERFORMANCE

CFM	Available External Static Pressure (in. wg)									
	0.2		0.4		0.6		0.8		1.0	
	RPM	BHP	RPM	BHP	RPM	BHP	RPM	BHP	RPM	BHP
6,000	497	0.84	603	1.20	683	1.53	752	1.86	814	2.19
6,500	517	1.00	623	1.39	703	1.76	772	2.12	833	2.48
7,000	536	1.17	643	1.61	724	2.01	792	2.40	852	2.78
7,500	555	1.35	664	1.85	744	2.29	812	2.70	872	3.12
8,000	573	1.56	684	2.11	765	2.59	832	3.04	892	3.48
8,500	591	1.77	704	2.39	785	2.91	853	3.40	912	3.87
9,000	607	2.00	724	2.70	805	3.26	873	3.79	933	4.29
9,500	622	2.25	743	3.02	826	3.64	894	4.21	953	4.75
10,000	635	2.50	762	3.38	846	4.04	914	4.65	974	5.23

CFM	Available External Static Pressure (in. wg)									
	1.2		1.4		1.6		1.8		2.0	
	RPM	BHP	RPM	BHP	RPM	BHP	RPM	BHP	RPM	BHP
6,000	870	2.53	922	2.88	971	3.23	1018	3.59	1062	3.96
6,500	889	2.84	941	3.20	989	3.58	1035	3.96	1079	4.35
7,000	908	3.17	959	3.56	1007	3.96	1053	4.36	1096	4.76
7,500	927	3.53	978	3.94	1026	4.36	1071	4.79	1114	5.21
8,000	947	3.92	998	4.36	1045	4.80	1090	5.25	1133	5.70
8,500	967	4.34	1017	4.81	1064	5.28	1109	5.75	1151	6.22
9,000	987	4.79	1037	5.29	1084	5.78	1128	6.28	1170	6.78
9,500	1007	5.28	1057	5.80	1104	6.33	1148	6.85	1190	7.37
10,000	1028	5.80	1077	6.35	1124	6.90	1168	7.45	—	—

NOTES:

1. **Boldface** indicates field-supplied drive is required.
2. *Italics* requires high static drive package with different motor pulley.

- Standard static 690-863 RPM; 208V (6.5 Max BHP) / 230V (6.9 Max BHP) / 460V (7.0 Max BHP) / 575 V (8.3 Max BHP)
- Medium static 835-1021 RPM; 208V (6.5 Max BHP) / 230V (6.9 Max BHP) / 460V (7.0 Max BHP) / 575 V (8.3 Max BHP)
- High static 941-1176 RPM; 208V (10.5 Max BHP) / 230V (11.9 Max BHP) / 460V (11.9 Max BHP) / 575 V (11.0 Max BHP)

50HC**24, 20 TON, HORIZONTAL SUPPLY/RETURN — FAN PERFORMANCE

CFM	Available External Static Pressure (in. wg)									
	0.2		0.4		0.6		0.8		1.0	
	RPM	BHP	RPM	BHP	RPM	BHP	RPM	BHP	RPM	BHP
6,000	575	1.54	645	2.01	708	2.51	764	3.02	815	3.56
6,500	610	1.87	677	2.37	738	2.90	792	3.45	842	4.02
7,000	646	2.25	710	2.79	768	3.35	821	3.93	870	4.53
7,500	683	2.68	744	3.25	800	3.85	851	4.46	899	5.09
8,000	720	3.17	779	3.78	832	4.41	882	5.05	929	5.72
8,500	758	3.73	814	4.36	865	5.02	913	5.70	959	6.40
9,000	796	4.34	849	5.01	899	5.71	946	6.42	<u>990</u>	<u>7.15</u>
9,500	834	5.03	885	5.73	933	6.46	978	7.20	1021	7.96
10,000	873	5.78	921	6.52	968	7.28	1011	8.06	1053	8.86

CFM	Available External Static Pressure (in. wg)									
	1.2		1.4		1.6		1.8		2.0	
	RPM	BHP	RPM	BHP	RPM	BHP	RPM	BHP	RPM	BHP
6,000	863	4.11	907	4.68	949	5.26	989	5.86	1026	6.47
6,500	889	4.60	933	5.20	974	5.82	1013	6.44	1051	7.09
7,000	916	5.14	959	5.77	1000	6.42	1039	7.08	1076	7.75
7,500	944	5.74	986	6.40	1026	7.08	1064	7.77	—	—
8,000	972	6.39	1014	7.09	1053	7.79	1091	8.51	—	—
8,500	1002	7.11	1042	7.83	1081	8.57	—	—	—	—
9,000	1031	7.89	1071	8.65	—	—	—	—	—	—
9,500	1062	8.74	—	—	—	—	—	—	—	—
10,000	1093	9.66	—	—	—	—	—	—	—	—

NOTES:

1. **Boldface** indicates field-supplied drive is required.
2. *Italics* requires high static drive package with different motor pulley.
3. Underscored text indicates the operation point is covered by mid-static drive. Confirm Max BHP coverage based on unit voltage selected.

- Standard static 690-863 RPM; 208V (6.5 Max BHP) / 230V (6.9 Max BHP) / 460V (7.0 Max BHP) / 575 V (8.3 Max BHP)
- Medium static 835-1021 RPM; 208V (6.5 Max BHP) / 230V (6.9 Max BHP) / 460V (7.0 Max BHP) / 575 V (8.3 Max BHP)
- High static 941-1100 RPM; 208V (10.5 Max BHP) / 230V (11.9 Max BHP) / 460V (11.9 Max BHP) / 575 V (11.0 Max BHP)



50HC**28, 25 TON, VERTICAL SUPPLY/RETURN — FAN PERFORMANCE

CFM	Available External Static Pressure (in. wg)									
	0.2		0.4		0.6		0.8		1.0	
	RPM	BHP	RPM	BHP	RPM	BHP	RPM	BHP	RPM	BHP
7,500	555	1.35	664	1.85	744	2.29	812	2.70	872	3.12
8,150	579	1.62	690	2.19	771	2.68	838	3.14	898	3.60
8,750	599	1.89	714	2.54	795	3.08	863	3.59	923	4.08
9,400	619	2.20	739	2.96	822	3.56	889	4.12	949	4.65
10,000	635	2.50	762	3.38	846	4.04	914	4.65	974	5.23
10,650	649	2.82	787	3.86	872	4.61	940	5.28	1000	5.91
11,250	653	3.09	808	4.35	895	5.17	965	5.90	<u>1025</u>	<u>6.58</u>
11,900	647	3.31	831	4.91	921	5.83	<u>991</u>	<u>6.63</u>	<u>1051</u>	<u>7.37</u>
12,500	641	3.51	851	5.46	943	6.48	<u>1015</u>	<u>7.34</u>	<u>1075</u>	<u>8.14</u>

CFM	Available External Static Pressure (in. wg)									
	1.2		1.4		1.6		1.8		2.0	
	RPM	BHP	RPM	BHP	RPM	BHP	RPM	BHP	RPM	BHP
7,500	927	3.53	978	3.94	1026	4.36	1071	4.79	1114	5.21
8,150	953	4.04	1003	4.49	1051	4.94	1096	5.39	1138	5.85
8,750	977	4.56	1027	5.04	1074	5.53	1118	6.01	1161	6.49
9,400	1003	5.18	1053	5.70	1100	6.21	1144	6.73	<i>1186</i>	<i>7.25</i>
10,000	1028	5.80	1077	6.35	1124	6.90	1168	7.45	—	—
10,650	<u>1054</u>	<u>6.52</u>	<u>1104</u>	<u>7.12</u>	1150	7.71	—	—	—	—
11,250	<u>1079</u>	<u>7.24</u>	1128	7.88	1174	8.51	—	—	—	—
11,900	<u>1105</u>	<u>8.07</u>	1155	8.76	—	—	—	—	—	—
12,500	1130	8.90	<i>1179</i>	<i>9.63</i>	—	—	—	—	—	—

NOTES:

1. **Boldface** indicates field-supplied drive is required.
2. *Italics* requires high static drive package with different motor pulley.
3. Underscored text indicates the operation point is covered by mid-static drive. Confirm Max BHP coverage based on unit voltage selected.

- Standard static 717-911 RPM, 4.9 BHP, max
- Medium static 913-1116 RPM; 208V (6.5 Max BHP) / 230V (6.9 Max BHP) / 460V (7.0 Max BHP) / 575 V (8.3 Max BHP)
- High static 941-1176 RPM; 208V (10.5 Max BHP) / 230V (11.9 Max BHP) / 460V (11.9 Max BHP) / 575 V (11.0 Max BHP)

50HC**28, 25 TON, HORIZONTAL SUPPLY/RETURN — FAN PERFORMANCE

CFM	Available External Static Pressure (in. wg)									
	0.2		0.4		0.6		0.8		1.0	
	RPM	BHP	RPM	BHP	RPM	BHP	RPM	BHP	RPM	BHP
7,500	683	2.68	744	3.25	800	3.85	851	4.46	899	5.09
8,000	720	3.17	779	3.78	832	4.41	882	5.05	929	5.72
8,500	758	3.73	814	4.36	865	5.02	913	5.70	959	6.40
9,000	796	4.34	849	5.01	899	5.71	946	6.42	990	7.15
9,500	834	5.03	885	5.73	933	6.46	978	7.20	1021	7.96
10,000	873	5.78	921	6.52	968	7.28	1011	8.06	1053	8.86
10,500	911	6.62	958	7.39	1003	8.18	1045	8.99	1086	9.82
11,000	950	7.53	995	8.34	1038	9.16	1079	10.01	—	—
11,500	989	8.53	1033	9.37	1074	10.23	—	—	—	—

CFM	Available External Static Pressure (in. wg)									
	1.2		1.4		1.6		1.8		2.0	
	RPM	BHP	RPM	BHP	RPM	BHP	RPM	BHP	RPM	BHP
7,500	944	5.74	986	6.40	1026	7.08	1064	7.77	—	—
8,000	972	6.39	1014	7.09	1053	7.79	1091	8.51	—	—
8,500	1002	7.11	1042	7.83	1081	8.57	—	—	—	—
9,000	1031	7.89	1071	8.65	—	—	—	—	—	—
9,500	1062	8.74	—	—	—	—	—	—	—	—
10,000	1093	9.66	—	—	—	—	—	—	—	—
10,500	—	—	—	—	—	—	—	—	—	—
11,000	—	—	—	—	—	—	—	—	—	—
11,500	—	—	—	—	—	—	—	—	—	—

NOTES:

1. **Boldface** indicates field-supplied drive is required.
2. *Italics* requires high static drive package with different motor pulley.

- Standard static 647-791 RPM, 4.9 BHP, max
- Medium static 755-923 RPM; 208V (6.5 Max BHP) / 230V (6.9 Max BHP) / 460V (7.0 Max BHP) / 575 V (8.3 Max BHP)
- High static 906-1100 RPM; 208V (10.5 Max BHP) / 230V (11.9 Max BHP) / 460V (11.9 Max BHP) / 575 V (11.0 Max BHP)



50HC17, 15 TON WITH EnergyX®, VERTICAL SUPPLY/RETURN — FAN PERFORMANCE**

CFM	Available External Static Pressure (in. wg)									
	0.2		0.4		0.6		0.8		1.0	
	RPM	BHP	RPM	BHP	RPM	BHP	RPM	BHP	RPM	BHP
4500	436	0.60	530	0.90	611	1.22	684	1.57	751	1.94
4900	456	0.71	546	1.03	625	1.37	695	1.73	760	2.12
5250	473	0.83	560	1.16	637	1.51	706	1.89	770	2.30
5600	491	0.95	575	1.30	650	1.67	717	2.07	780	2.48
6000	513	1.11	593	1.48	665	1.87	731	2.28	792	2.71
6400	534	1.29	611	1.68	681	2.09	745	2.52	805	2.97
6750	553	1.46	628	1.87	696	2.29	758	2.74	817	3.20
7100	573	1.65	645	2.07	711	2.51	772	2.98	829	3.46
7500	595	1.88	665	2.33	729	2.79	788	3.27	844	3.77

CFM	Available External Static Pressure (in. wg)									
	1.2		1.4		1.6		1.8		2.0	
	RPM	BHP	RPM	BHP	RPM	BHP	RPM	BHP	RPM	BHP
4500	812	2.33	869	2.74	924	3.17	975	3.62	1024	4.08
4900	821	2.53	877	2.95	931	3.40	981	3.86	1030	4.34
5250	829	2.72	885	3.16	938	3.61	988	4.09	1036	4.57
5600	838	2.92	893	3.37	945	3.84	994	4.33	1042	4.83
6000	849	3.17	903	3.63	954	4.12	1003	4.62	—	—
6400	861	3.43	914	3.92	964	4.42	1012	4.94	—	—
6750	872	3.69	924	4.18	973	4.70	—	—	—	—
7100	883	3.95	934	4.47	—	—	—	—	—	—
7500	897	4.28	947	4.81	—	—	—	—	—	—

NOTE: **Boldface** indicates field-supplied drive is required.

- Standard static 514-680 RPM, 2.2 Max BHP
- Medium static 679-863 RPM, 3.3 Max BHP
- High static 826-1009 RPM, 4.9 Max BHP

50HC**20, 17.5 TON WITH EnergyX®, VERTICAL SUPPLY/RETURN — FAN PERFORMANCE

CFM	Available External Static Pressure (in. wg)									
	0.2		0.4		0.6		0.8		1.0	
	RPM	BHP	RPM	BHP	RPM	BHP	RPM	BHP	RPM	BHP
5250	473	0.83	560	1.16	637	1.51	706	1.89	770	2.30
5700	497	0.99	580	1.34	654	1.72	721	2.12	783	2.54
6100	518	1.15	598	1.53	669	1.92	735	2.34	795	2.78
6500	540	1.33	616	1.73	685	2.14	749	2.58	808	3.03
7000	567	1.59	640	2.01	707	2.45	768	2.91	826	3.38
7500	595	1.88	665	2.33	729	2.79	788	3.27	844	3.77
7900	618	2.14	685	2.60	747	3.09	805	3.59	859	4.10
8300	641	2.42	705	2.91	765	3.41	822	3.93	875	4.46
8750	666	2.77	729	3.28	787	3.80	842	4.34	893	4.90

CFM	Available External Static Pressure (in. wg)									
	1.2		1.4		1.6		1.8		2.0	
	RPM	BHP	RPM	BHP	RPM	BHP	RPM	BHP	RPM	BHP
5250	829	2.72	885	3.16	938	3.61	988	4.09	1036	4.57
5700	841	2.98	895	3.43	947	3.91	997	4.40	1044	4.90
6100	852	3.23	906	3.70	957	4.19	1005	4.70	1052	5.22
6500	864	3.50	917	3.99	967	4.50	1015	5.02	1060	5.55
7000	880	3.88	931	4.38	980	4.91	1027	5.45	1072	6.01
7500	897	4.28	947	4.81	995	5.36	1041	5.92	1085	6.49
7900	911	4.63	960	5.18	1007	5.75	1052	6.32	—	—
8300	926	5.01	974	5.58	1020	6.16	—	—	—	—
8750	943	5.47	990	6.05	—	—	—	—	—	—

NOTE: **Boldface** indicates field-supplied drive is required.

- Standard static 622-822 RPM; 3.3 Max BHP
- Medium static 713-879 RPM, 4.9 Max BHP
- High static 882-1078 RPM, 6.5 Max BHP

50HC**24, 20 TON WITH EnergyX®, VERTICAL SUPPLY/RETURN — FAN PERFORMANCE

CFM	Available External Static Pressure (in. wg)									
	0.2		0.4		0.6		0.8		1.0	
	RPM	BHP	RPM	BHP	RPM	BHP	RPM	BHP	RPM	BHP
6,000	506	1.12	593	1.43	668	1.74	736	2.07	798	2.40
6,500	533	1.36	616	1.70	689	2.04	754	2.39	815	2.74
7,000	561	1.64	640	2.01	710	2.37	774	2.74	833	3.11
7,500	588	1.96	664	2.35	732	2.74	795	3.13	852	3.53
8,000	617	2.32	689	2.74	755	3.15	816	3.57	872	3.99
8,500	645	2.73	715	3.17	779	3.60	837	4.04	892	4.49
9,000	674	3.18	741	3.64	803	4.10	860	4.57	913	5.04
9,500	703	3.67	767	4.16	827	4.65	883	5.14	935	5.64
10,000	732	4.22	794	4.74	852	5.25	906	5.77	957	6.29

CFM	Available External Static Pressure (in. wg)									
	1.2		1.4		1.6		1.8		2.0	
	RPM	BHP	RPM	BHP	RPM	BHP	RPM	BHP	RPM	BHP
6,000	855	2.75	909	3.11	959	3.47	1008	3.85	1054	4.24
6,500	871	3.11	924	3.48	974	3.87	1022	4.26	1067	4.67
7,000	888	3.50	940	3.89	989	4.30	1036	4.71	1081	5.13
7,500	906	3.94	957	4.35	1005	4.77	1052	5.20	1096	5.64
8,000	925	4.42	975	4.85	1022	5.29	1068	5.74	1111	6.20
8,500	944	4.94	993	5.40	1040	5.86	1084	6.33	1127	6.81
9,000	964	5.51	1012	5.99	1058	6.48	1102	6.97	1144	7.46
9,500	984	6.13	1032	6.64	1077	7.14	1120	7.65	1161	8.17
10,000	1006	6.81	1052	7.33	1096	7.86	1138	8.40	—	—

NOTE: **Boldface** indicates field-supplied drive is required.

- Standard static 690-863 RPM, 4.9 Max BHP
- Medium static 835-1021 RPM, 6.5 Max BHP
- High static 941-1176 RPM, 8.7 Max BHP



50HC**28 WITH EnergyX®, 24 TON, VERTICAL SUPPLY/RETURN — FAN PERFORMANCE

CFM	Available External Static Pressure (in. wg)									
	0.2		0.4		0.6		0.8		1.0	
	RPM	BHP	RPM	BHP	RPM	BHP	RPM	BHP	RPM	BHP
7,500	541	1.50	636	1.88	716	2.27	787	2.66	850	3.06
8,000	563	1.76	656	2.17	735	2.58	804	3.00	867	3.42
8,500	585	2.05	676	2.50	753	2.93	822	3.37	884	3.81
9,000	608	2.37	697	2.85	772	3.31	840	3.77	901	4.24
9,500	631	2.73	717	3.24	791	3.73	858	4.21	918	4.70
10,000	654	3.12	738	3.66	811	4.18	876	4.69	936	5.20
10,500	678	3.56	759	4.12	831	4.67	895	5.21	954	5.74
11,000	701	4.02	781	4.62	851	5.20	914	5.76	972	6.33
11,500	725	4.53	802	5.16	871	5.77	933	6.36	991	6.95
12,000	748	5.09	824	5.75	892	6.38	953	7.00	1010	7.62
12,500	772	5.68	846	6.38	912	7.04	973	7.69	1029	8.34

CFM	Available External Static Pressure (in. wg)									
	1.2		1.4		1.6		1.8		2.0	
	RPM	BHP	RPM	BHP	RPM	BHP	RPM	BHP	RPM	BHP
7,500	909	3.47	963	3.89	1014	4.32	1062	4.77	1108	5.23
8,000	925	3.85	978	4.29	1029	4.74	1077	5.20	1122	5.68
8,500	941	4.26	994	4.72	1044	5.19	1092	5.67	1137	6.16
9,000	957	4.71	1010	5.19	1060	5.67	1107	6.17	1152	6.68
9,500	974	5.19	1027	5.69	1076	6.20	1123	6.72	1167	7.24
10,000	991	5.72	1043	6.24	1092	6.77	1138	7.30	—	—
10,500	1009	6.28	1060	6.83	1109	7.37	1155	7.93	—	—
11,000	1026	6.89	1077	7.46	1125	8.03	1171	8.60	—	—
11,500	1044	7.54	1095	8.13	1142	8.72	—	—	—	—
12,000	1062	8.23	1112	8.85	—	—	—	—	—	—
12,500	—	—	—	—	—	—	—	—	—	—

NOTE: **Boldface** indicates field-supplied drive is required.

- Standard static 717-911 RPM, 4.9 Max BHP 2.2
- Medium static 913-1116 RPM, 6.5 Max BHP
- High static 941-1176 RPM, 8.7 Max BHP

FAN PERFORMANCE — POWER EXHAUST

AIRFLOW (cfm)	208V		230V/460V/575V	
	ESP	BHP	ESP	BHP
3,850	0.600	1.845	0.730	1.99
3,950	0.560	1.870	0.690	2.01
4,050	0.510	1.890	0.650	2.04
4,250	0.410	1.915	0.560	2.06
4,450	0.310	1.965	0.470	2.12
4,650	0.200	2.035	0.370	2.19
4,850	0.110	2.085	0.300	2.24
5,050	0.040	2.125	0.230	2.28
5,250	—	—	0.170	2.33
5,450	—	—	0.120	2.38
5,650	—	—	0.070	2.40
5,850	—	—	0.040	2.42

PULLEY ADJUSTMENT, VERTICAL

50HC UNIT	MOTOR/DRIVE COMBO	MOTOR PULLEY TURNS OPEN (RPM)											
		0	0.5	1	1.5	2	2.5	3	3.5	4	4.5	5	
17	3 phase	Standard Static	680	663	647	630	614	597	580	564	547	531	514
		Medium Static	863	845	826	808	789	771	753	734	716	697	679
		High Static	1009	991	972	954	936	918	899	881	863	844	826
20	3 phase	Standard Static	822	802	782	762	742	722	702	682	662	642	622
		Medium Static	879	862	846	829	813	796	779	763	746	730	713
		High Static	1078	1058	1039	1019	1000	980	960	941	921	902	882
24	3 phase	Standard Static	863	846	828	811	794	777	759	742	725	707	690
		Medium Static	1021	1002	984	965	947	928	909	891	872	854	835
		High Static	1176	1153	1129	1106	1082	1059	1035	1012	988	965	941
28	3 phase	Standard Static	911	892	872	853	833	814	795	775	756	736	717
		Medium Static	1116	1096	1075	1055	1035	1015	994	974	954	933	913
		High Static	1176	1153	1129	1106	1082	1059	1035	1012	988	965	941

NOTE: Do not adjust pulley further than 5 turns.

Factory setting

PULLEY ADJUSTMENT, HORIZONTAL

50HC UNIT	MOTOR/DRIVE COMBO	MOTOR PULLEY TURNS OPEN (RPM)											
		0	0.5	1	1.5	2	2.5	3	3.5	4	4.5	5	
17	3 phase	Standard Static	680	663	647	630	614	597	580	564	547	531	514
		Medium Static	780	763	747	730	714	697	680	664	647	631	614
		High Static	912	895	879	862	846	829	812	796	779	763	746
20	3 phase	Standard Static	822	802	782	762	742	722	702	682	662	642	622
		Medium Static	879	862	846	829	813	796	779	763	746	730	713
		High Static	1021	1002	984	965	947	928	909	891	872	854	835
24	3 phase	Standard Static	863	846	828	811	794	777	759	742	725	707	690
		Medium Static	1021	1002	984	965	947	928	909	891	872	854	835
		High Static	1176	1153	1129	1106	1082	1059	1035	1012	988	965	941
28	3 phase	Standard Static	791	777	762	748	733	719	705	690	676	661	647
		Medium Static	923	906	889	873	856	839	822	805	789	772	755
		High Static	1107	1087	1067	1047	1027	1007	986	966	946	926	906

NOTE: Do not adjust pulley further than 5 turns.

Factory setting

50HC**17-24 TYPICAL WIRING DIAGRAM (208/230V SHOWN)

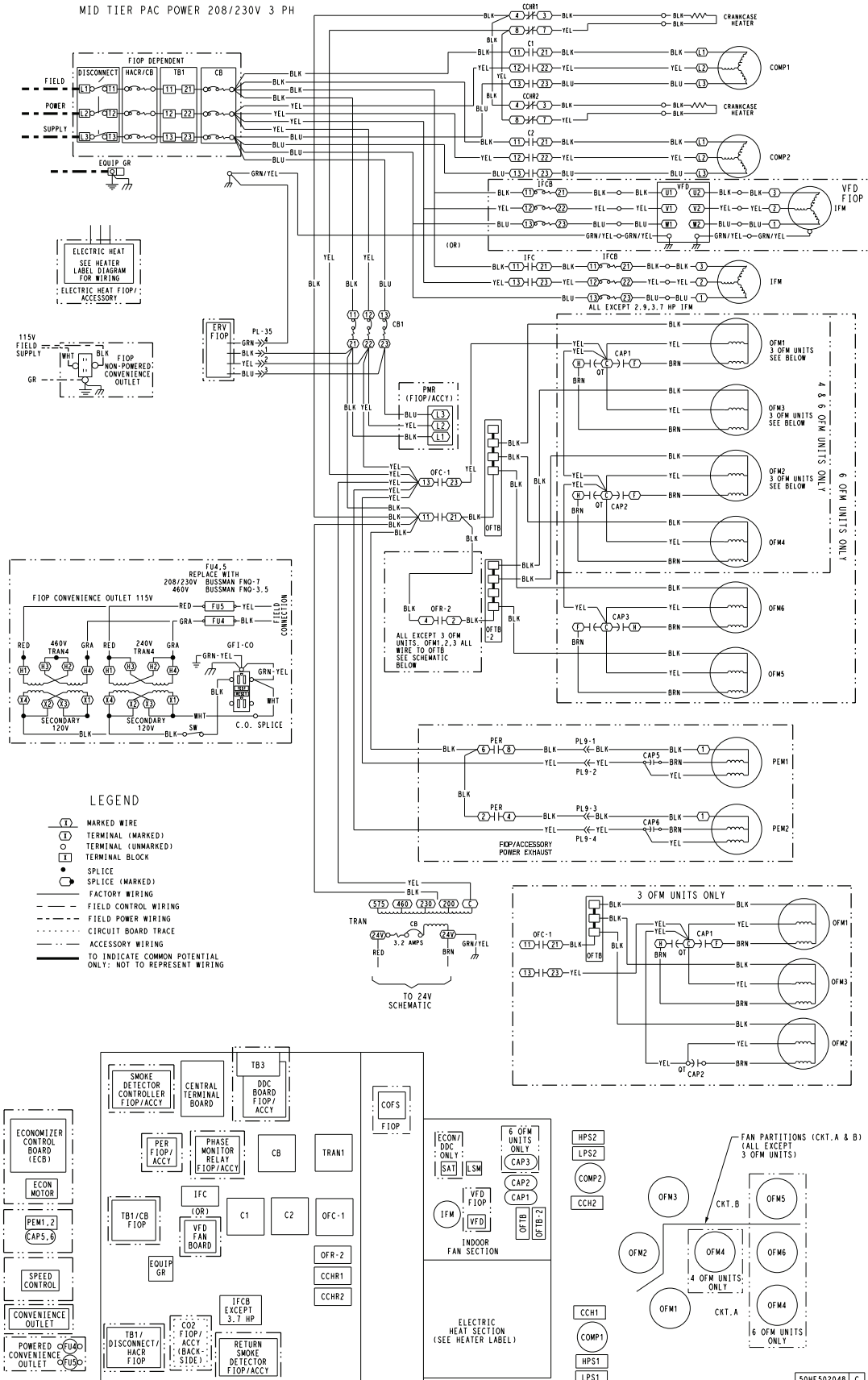

50HE502048 C

50HC**17-24 WITH ELECTRO-MECHANICAL CONTROL WIRING DIAGRAM

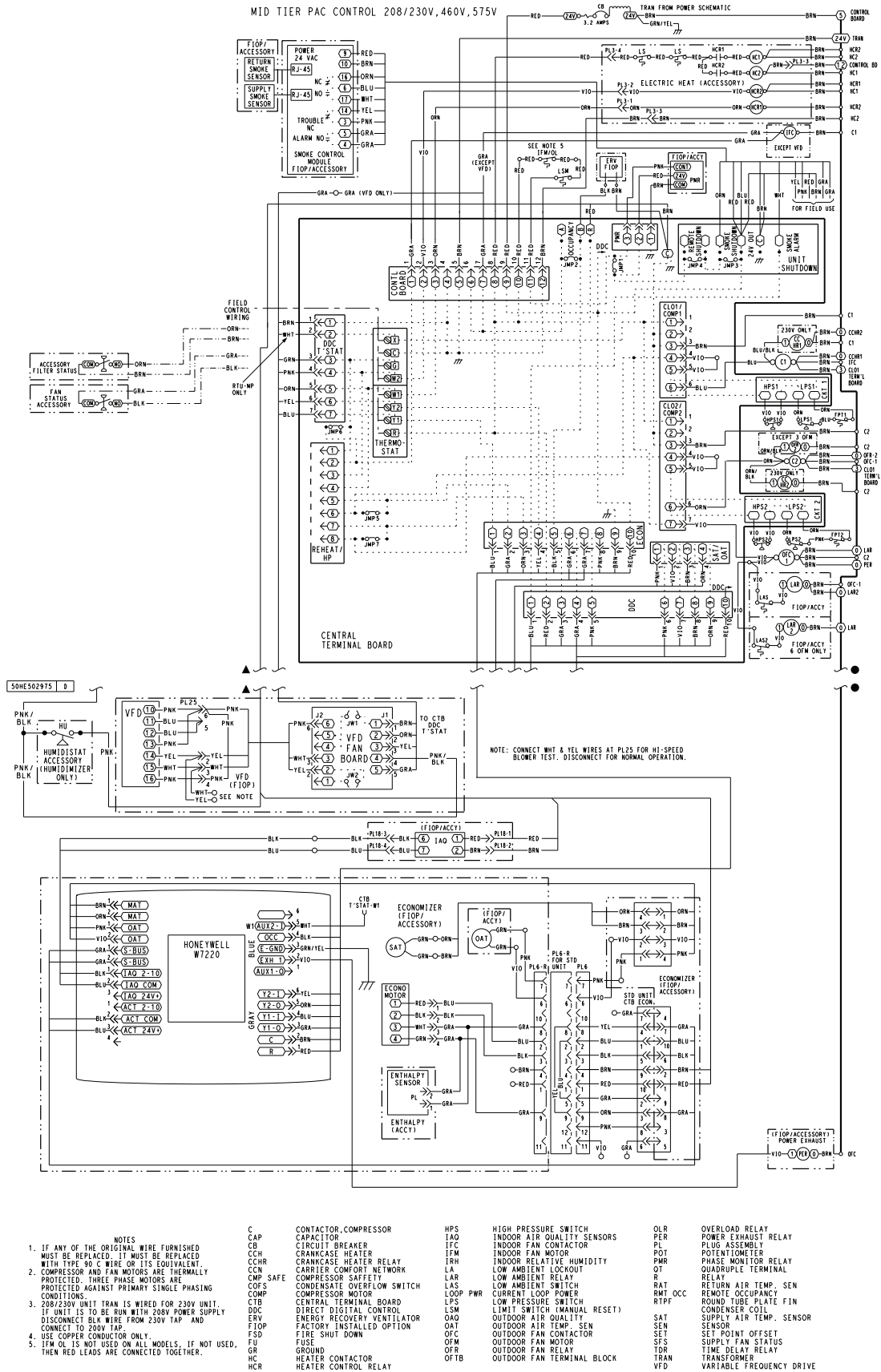

50HC**17-24 WITH ELECTRO-MECHANICAL CONTROL AND OPTIONAL Humidi-MiZer® WIRING DIAGRAM

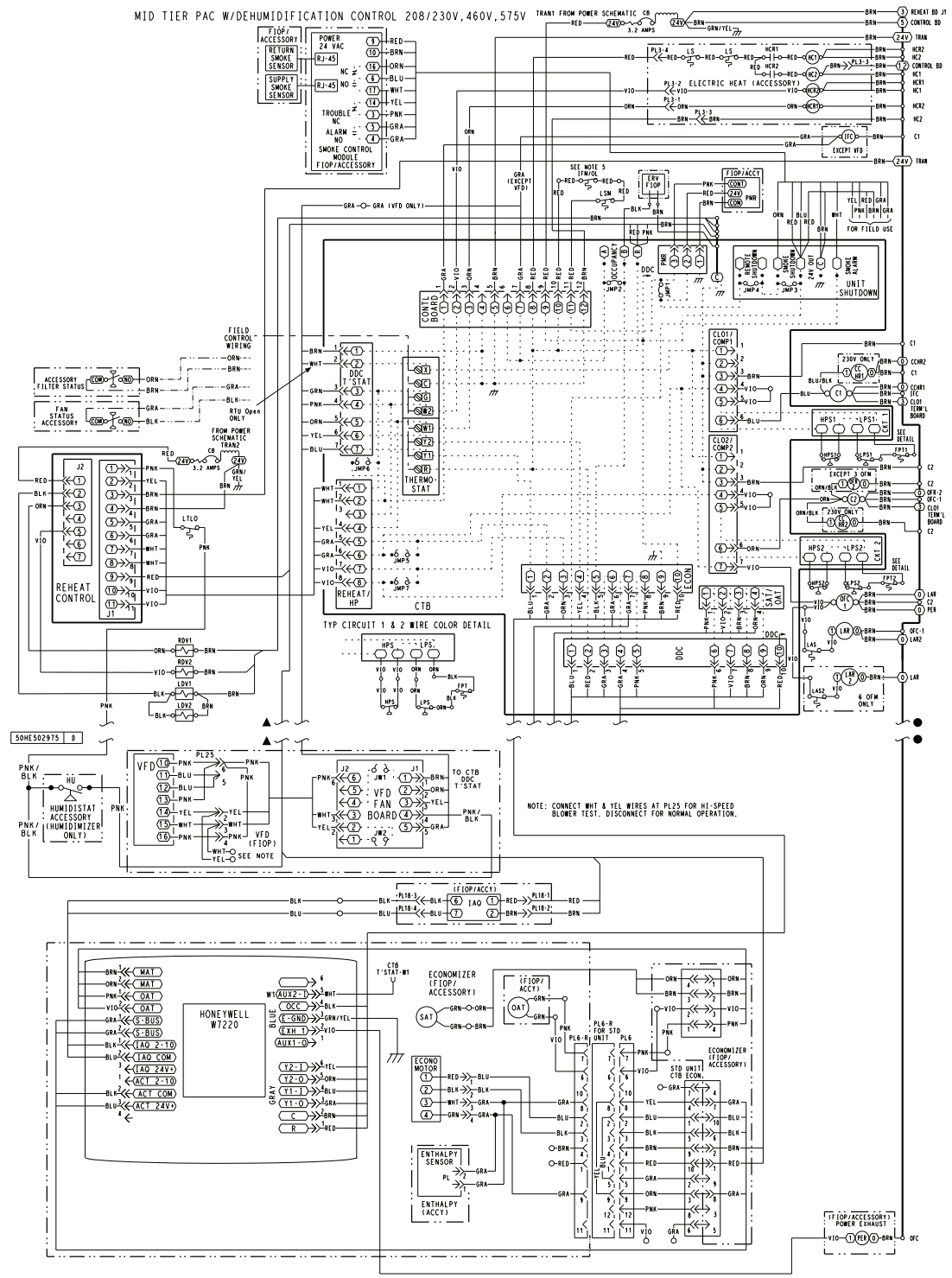

- NOTES**
1. IF ANY OF THE ORIGINAL WIRE FURNISHED MUST BE REPLACED, IT MUST BE REPLACED WITH TYPE 90 C WIRE OR ITS EQUIVALENT.
 2. COMPRESSOR AND FAN MOTORS ARE THERMALLY PROTECTED, THREE PHASE MOTORS ARE PROTECTED AGAINST PRIMARY SINGLE PHASING CONDITIONS.
 3. 208/230V UNIT TRANS IS WIRED FOR 230V UNIT. IF UNIT IS TO BE RUN WITH 208V POWER SUPPLY DISCONNECT BLK WIRE FROM 230V TAP AND CONNECT TO 200V TAP.
 4. USE COPPER CONDUCTOR ONLY.
 5. IFM OLS IS NOT USED ON ALL MODELS. WHEN NOT USED, RED LEADS ARE CONNECTED TOGETHER.

C	CONTACTOR, COMPRESSOR	HPS	HIGH PRESSURE SWITCH	OLR	OVERLOAD RELAY
CAP	CAPACITOR	IAQ	INDOOR AIR QUALITY SENSORS	PER	POWER EXHAUST RELAY
CB	CIRCUIT BREAKER	IFC	INDOOR FAN CONTACTOR	PI	PLUG ASSEMBLY
CC	CRANKCASE HEATER	IFM	INDOOR FAN MOTOR	POT	POTENTIOMETER
CCHR	CRANKCASE HEATER RELAY	IRH	INDOOR RELATIVE HUMIDITY	PWR	PHASE MONITOR RELAY
CCK	CARRIER COMFORT NETWORK	LAR	LOW AMBIENT LOCKOUT	QTR	QUADRUPLE TERMINAL
COMP	COMPRESSOR SAFETY	LAS	LOW AMBIENT SWITCH	R	RELAY
COPFS	CONDENSATE OVERFLOW SWITCH	LDV	LIQUID DIVERTER VALVE (3-WAY)	RAT	RETURN AIR TEMP. SEN
CMP SAFE	COMPRESSOR SAFETY	LSM	LIMIT SWITCH (MANUAL RESET)	RDV	REHEAT DISCHARGE VALVE
CTB	CENTRAL TERMINAL BOARD	LSM	LIMIT SWITCH (MANUAL RESET)	RMT OCC	REMOTE OCCUPANCY
DDC	DIRECT DIGITAL CONTROL	OAO	OUTDOOR AIR QUALITY	RTRF	ROUND TUBE PLATE FIN
ERV	ENERGY RECOVERY VENTILATOR	OAT	OUTDOOR AIR TEMP. SEN	SEN	SENSOR
F1OP	FREQUENCY PROTECTION THERMOSTAT	OFM	OUTDOOR FAN MOTOR	SET	SET POINT OFFSET
FPT	FREZE PROTECTION THERMOSTAT	OFM	OUTDOOR FAN MOTOR	SFS	SUPPLY AIR TEMP. SENSOR
FSD	FUSE	OFM	OUTDOOR FAN MOTOR	SFS	SUPPLY AIR TEMP. SENSOR
FU	FUSE	OFM	OUTDOOR FAN MOTOR	TDR	TIME DELAY RELAY
GR	GROUND	OFM	OUTDOOR FAN MOTOR	TRN	TRANSFORMER
HC	HEATER CONTACTOR	OFM	OUTDOOR FAN MOTOR	VFD	VARIABLE FREQUENCY DRIVE
HCR	HEATER CONTROL RELAY				

50HE502357 | E

50HC**17-24 WITH OPTIONAL Humidi-MiZer® WIRING DIAGRAM (208/230V SHOWN)

MID TIER PAC W/DEHUMIDIFICATION POWER 208/230V 3 PH

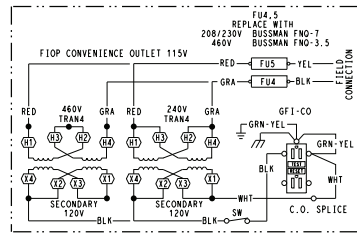
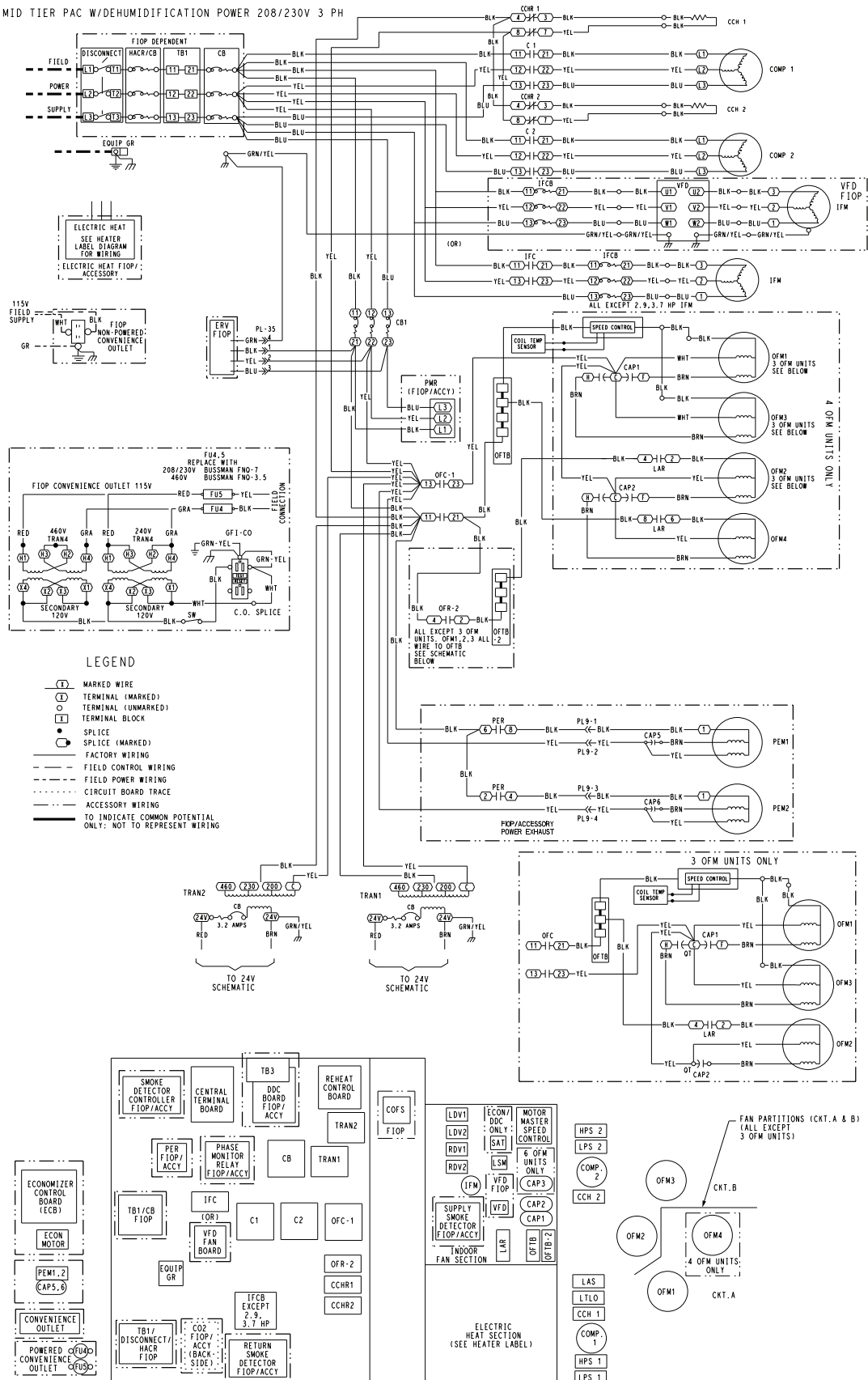

- LEGEND**
- Ⓜ MARKED WIRE
 - Ⓞ TERMINAL (MARKED)
 - TERMINAL (UNMARKED)
 - TERMINAL BLOCK
 - SPLICE
 - SPLICE (MARKED)
 - FACTORY WIRING
 - - - FIELD CONTROL WIRING
 - - - FIELD POWER WIRING
 - ⋯ CIRCUIT BOARD TRACE
 - ACCESSORY WIRING
 - TO INDICATE COMMON POTENTIAL ONLY; NOT TO REPRESENT WIRING

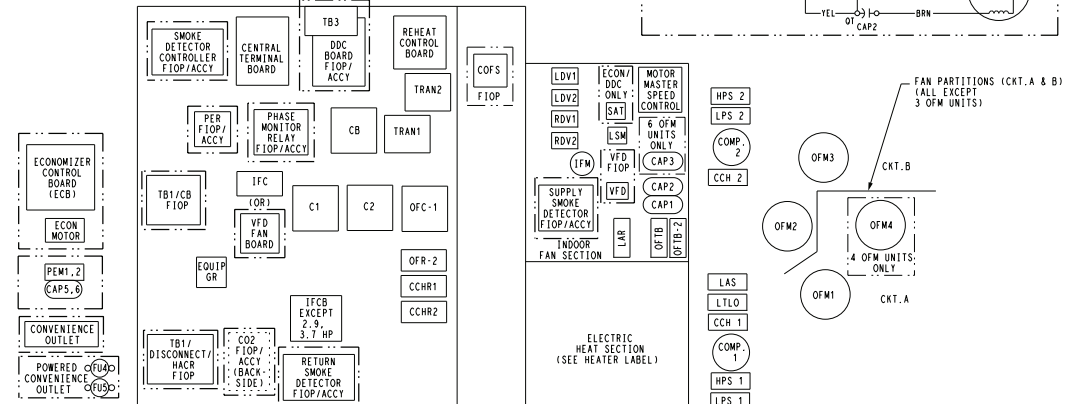
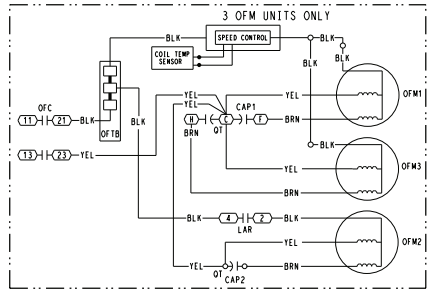
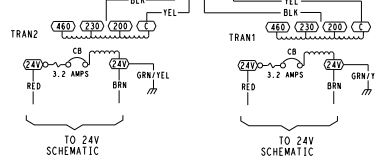

50HC WITH EnergyX[®] TYPICAL WIRING DIAGRAM

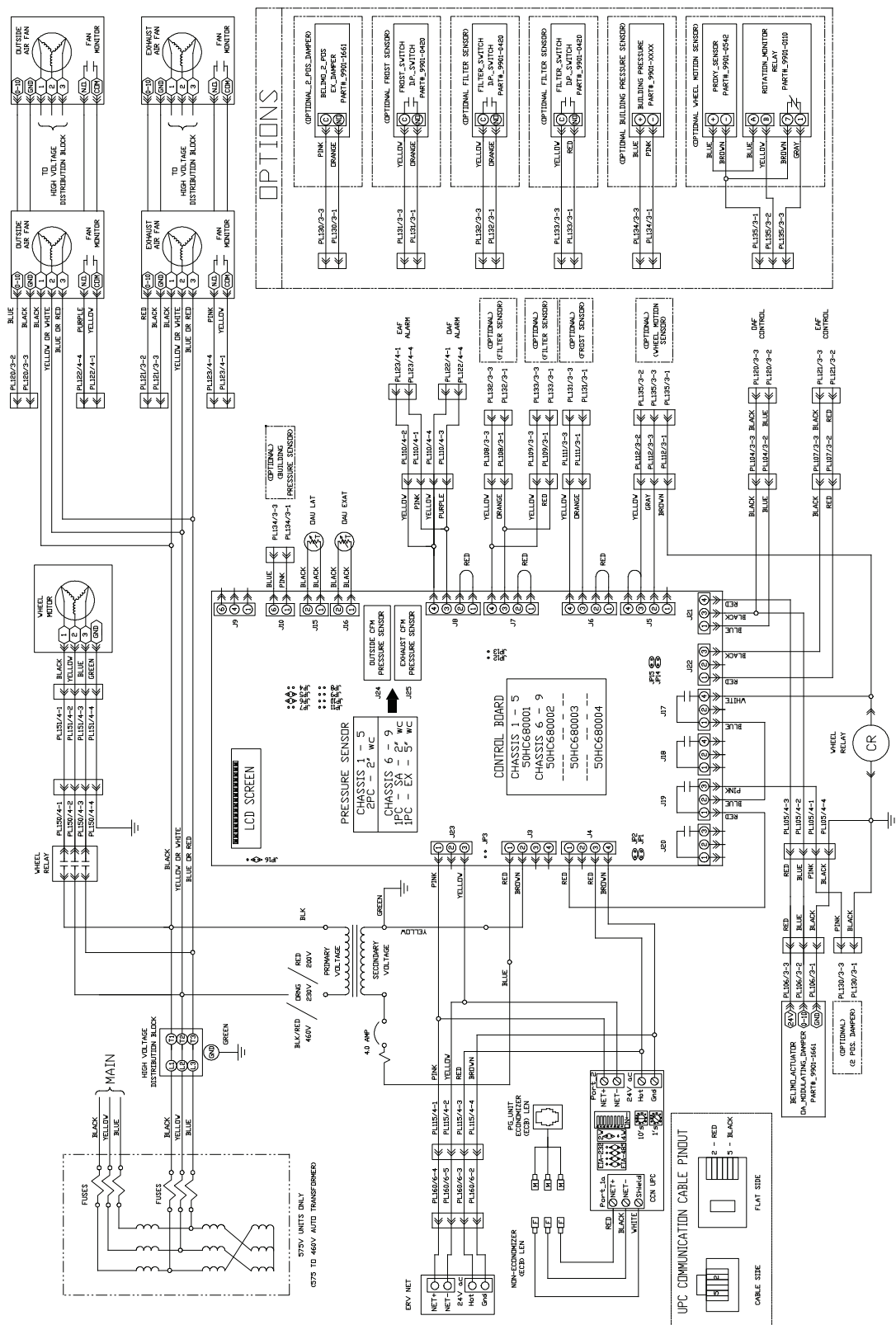

50HC**17-28 COOLING ELECTRICAL DATA — WITHOUT EnergyX

50HC UNIT	V-Ph-Hz	UNIT VOLTAGE RANGE		COMP 1		COMP 2		OFM (EA)		IFM			POWER EXHAUST	
		MIN	MAX	RLA	LRA	RLA	LRA	WATTS	FLA	TYPE	EFF at Full Load (%)	FLA	Motor QTY	FLA (ea motor)
50HC**17	208-3-60	187	253	25.0	164	25.0	164	350	1.5	STD	81.3	7.5	2	5.9
										MED	87.0	10.6		
										HIGH	82.9	13.6		
	230-3-60	187	253	25.0	164	25.0	164	350	1.5	STD	81.3	7.5	2	5.9
										MED	87.0	10.6		
										HIGH	82.9	12.7		
	460-3-60	414	506	12.8	100	12.8	100	277	0.9	STD	81.3	3.4	2	3.1
										MED	87.0	5.3		
										HIGH	82.9	6.4		
	575-3-60	518	633	9.6	78	9.6	78	397	0.6	STD	81.1	2.8	2	2.4
										MED	81.1	2.8		
										HIGH	83.6	5.6		
50HC**20	208-3-60	187	253	27.6	191	25.0	164	350	1.5	STD	83.8	10.2	2	5.9
										MED	82.9	13.6		
										HIGH-HE	89.5	17.1		
	230-3-60	187	253	27.6	191	25.0	164	350	1.5	STD	83.8	10.2	2	5.9
										MED	82.9	12.7		
										HIGH-HE	89.5	17.1		
	460-3-60	414	506	12.8	100	12.2	100	277	0.9	STD	83.8	4.8	2	3.1
										MED	82.9	6.4		
										HIGH-HE	89.5	8.6		
	575-3-60	518	633	9.6	78	9.0	78	397	0.6	STD	81.1	2.8	2	2.4
										MED	83.6	5.6		
										HIGH-HE	89.5	7.6		
50HC**24	208-3-60	187	253	28.2	239	28.2	239	350	1.5	STD	89.5	17.1	2	5.9
										MED-HE	89.5	17.1		
										HIGH-HE	91.7	28.5		
	230-3-60	187	253	28.2	239	28.2	239	350	1.5	STD	89.5	17.1	2	5.9
										MED-HE	89.5	17.1		
										HIGH-HE	91.7	28.5		
	460-3-60	414	506	14.7	130	14.7	130	277	0.9	STD	89.5	8.6	2	3.1
										MED-HE	89.5	8.6		
										HIGH-HE	91.7	14.3		
	575-3-60	518	633	11.3	94	11.3	94	397	0.6	STD	83.6	5.6	2	2.4
										MED-HE	89.5	7.6		
										HIGH-HE	91.7	9.5		
50HC**28	208-3-60	187	253	48.1	245	33.9	240	350	1.5	STD	82.9	13.6	2	5.9
										MED-HE	89.5	17.1		
										HIGH-HE	91.7	28.5		
	230-3-60	187	253	48.1	245	33.9	240	350	1.5	STD	82.9	12.7	2	5.9
										MED-HE	89.5	17.1		
										HIGH-HE	91.7	28.5		
	460-3-60	414	506	18.6	125	16.0	140	277	0.9	STD	82.9	6.4	2	3.1
										MED-HE	89.5	8.6		
										HIGH-HE	91.7	14.3		
	575-3-60	518	633	14.7	100	12.9	108	397	0.6	STD	83.6	5.6	2	2.4
										MED-HE	89.5	7.6		
										HIGH-HE	91.7	9.5		

See Legend and Notes on page 86.



50HC17-28 COOLING WITH TWO-SPEED BLOWER ELECTRICAL DATA — WITHOUT EnergyX**

50HC UNIT	V-Ph-Hz	UNIT VOLTAGE RANGE		COMP 1		COMP 2		OFM (EA)		IFM			POWER EXHAUST	
		MIN	MAX	RLA	LRA	RLA	LRA	WATTS	FLA	TYPE	EFF at Full Load (%)	FLA	Motor QTY	FLA (ea motor)
50HC**17	208-3-60	187	253	25.0	164	25.0	164	350	1.5	STD	85.0	8.6	2	5.9
										MED	81.5	10.8		
										HIGH	83.6	13.6		
	230-3-60	187	253	25.0	164	25.0	164	350	1.5	STD	85.0	7.8	2	5.9
										MED	81.5	9.8		
										HIGH	83.6	12.7		
	460-3-60	414	506	12.8	100	12.8	100	277	0.9	STD	85.0	3.8	2	3.1
										MED	81.5	4.9		
										HIGH	83.6	6.4		
	575-3-60	518	633	9.6	78	9.6	78	397	0.6	STD	81.1	4.5	2	2.4
										MED	81.1	4.5		
										HIGH	83.6	6.2		
50HC**20	208-3-60	187	253	27.6	191	25.0	164	350	1.5	STD	81.5	10.8	2	5.9
										MED	83.6	13.6		
										HIGH	89.5	17.1		
	230-3-60	187	253	27.6	191	25.0	164	350	1.5	STD	81.5	9.8	2	5.9
										MED	83.6	12.7		
										HIGH	89.5	17.1		
	460-3-60	414	506	12.8	100	12.2	100	277	0.9	STD	81.5	4.9	2	3.1
										MED	83.6	6.4		
										HIGH	89.5	8.6		
	575-3-60	518	633	9.6	78	9.0	78	397	0.6	STD	81.1	4.5	2	2.4
										MED	83.6	6.2		
										HIGH	89.5	7.6		
50HC**24	208-3-60	187	253	28.2	239	28.2	239	350	1.5	STD	83.6	13.6	2	5.9
										MED	89.5	17.1		
										HIGH	91.7	28.5		
	230-3-60	187	253	28.2	239	28.2	239	350	1.5	STD	83.6	12.7	2	5.9
										MED	89.5	17.1		
										HIGH	91.7	28.5		
	460-3-60	414	506	14.7	130	14.7	130	277	0.9	STD	83.6	6.4	2	3.1
										MED	89.5	8.6		
										HIGH	91.7	14.3		
	575-3-60	518	633	11.3	94	11.3	94	397	0.6	STD	83.6	6.2	2	2.4
										MED	89.5	7.6		
										HIGH	91.7	9.5		
50HC**28	208-3-60	187	253	48.1	245	33.9	240	350	1.5	STD	83.6	13.6	2	5.9
										MED	89.5	17.1		
										HIGH	91.7	28.5		
	230-3-60	187	253	48.1	245	33.9	240	350	1.5	STD	83.6	12.7	2	5.9
										MED	89.5	17.1		
										HIGH	91.7	28.5		
	460-3-60	414	506	18.6	125	16.0	140	277	0.9	STD	83.6	6.4	2	3.1
										MED	89.5	8.6		
										HIGH	91.7	14.3		
	575-3-60	518	633	14.7	100	12.9	108	397	0.6	STD	83.6	6.2	2	2.4
										MED	89.5	7.6		
										HIGH	91.7	9.5		

See Legend and Notes on page 86.



50HC**17-28 ELECTRIC HEAT ELECTRICAL DATA — WITHOUT EnergyX

50HC UNIT TYPE	NOMINAL V-Ph-Hz	IFM TYPE	ELECTRIC HEATER PART NUMBER CRHEATER***A00 (VERT./HORIZ.)	NOM. (kW)	APPLICATION (kW)	APPLICATION OUTPUT (MBH)	SINGLE POINT OR JUNCTION KIT PART NUMBER			
							NO C.O. OR UNPOWERED C.O.		WITH POWERED C.O.	
							NO P.E.	WITH P.E.	NO P.E.	WITH P.E.
50HC**17	208/230-3-60	STD	279/270	25.0	18.8/23.0	64.1/78.3	—	—	—	—
			280/271	50.0	37.6/45.9	128.1/156.7	056	056	056	056
			281/272	75.0	56.3/68.9	192.2/235.0	056	056	056	056
		MED	279/270	25.0	18.8/23.0	64.1/78.3	—	—	—	—
			280/271	50.0	37.6/45.9	128.1/156.7	056	056	056	056
			281/272	75.0	56.3/68.9	192.2/235.0	056	056	056	056
		HIGH	279/270	25.0	18.8/23.0	64.1/78.3	—	—	—	—
			280/271	50.0	37.6/45.9	128.1/156.7	056	056	056	056
			281/272	75.0	56.3/68.9	192.2/235.0	056	056	056	056
	460-3-60	STD	282/273	25.0	23.0	78.3	—	—	—	—
			283/274	50.0	45.9	156.7	—	057	-	057
			284/275	75.0	68.9	235.0	057	057	057	057
		MED	282/273	25.0	23.0	78.3	—	—	—	—
			283/274	50.0	45.9	156.7	057	057	057	057
			284/275	75.0	68.9	235.0	057	057	057	057
		HIGH	282/273	25.0	23.0	78.3	—	—	—	—
			283/274	50.0	45.9	156.7	057	057	057	057
			284/275	75.0	68.9	235.0	057	057	057	057
	575-3-60	STD	285/276	24.8	22.8	77.7	—	—	—	—
			286/277	49.6	45.6	155.4	—	—	—	057
			287/278	74.4	68.3	233.1	057	057	057	057
		MED	285/276	24.8	22.8	77.7	—	—	—	—
			286/277	49.6	45.6	155.4	—	—	—	057
			287/278	74.4	68.3	233.1	057	057	057	057
		HIGH	285/276	24.8	22.8	77.7	—	—	—	—
			286/277	49.6	45.6	155.4	—	057	—	057
			287/278	74.4	68.3	233.1	057	057	057	057
50HC**20	208/230-3-60	STD	279/270	25.0	18.8/23.0	64.1/78.3	—	—	—	—
			280/271	50.0	37.6/45.9	128.1/156.7	056	056	056	056
			281/272	75.0	56.3/68.9	192.2/235.0	056	056	056	056
		MED	279/270	25.0	18.8/23.0	64.1/78.3	—	—	—	—
			280/271	50.0	37.6/45.9	128.1/156.7	056	056	056	056
			281/272	75.0	56.3/68.9	192.2/235.0	056	056	056	056
		HIGH-HE	279/270	25.0	18.8/23.0	64.1/78.3	—	—	—	—
			280/271	50.0	37.6/45.9	128.1/156.7	056	056	056	056
			281/272	75.0	56.3/68.9	192.2/235.0	056	056	056	056
	460-3-60	STD	282/273	25.0	23.0	78.3	—	—	—	—
			283/274	50.0	45.9	156.7	057	057	057	057
			284/275	75.0	68.9	235.0	057	057	057	057
		MED	282/273	25.0	23.0	78.3	—	—	—	—
			283/274	50.0	45.9	156.7	057	057	057	057
			284/275	75.0	68.9	235.0	057	057	057	057
		HIGH-HE	282/273	25.0	23.0	78.3	—	—	—	—
			283/274	50.0	45.9	156.7	057	057	057	057
			284/275	75.0	68.9	235.0	057	057	057	057
	575-3-60	STD	285/276	24.8	22.8	77.7	—	—	—	—
			286/277	49.6	45.6	155.4	—	—	—	057
			287/278	74.4	68.3	233.1	057	057	057	057
		MED	285/276	24.8	22.8	77.7	—	—	—	—
			286/277	49.6	45.6	155.4	-	057	-	057
			287/278	74.4	68.3	233.1	057	057	057	057
		HIGH-HE	285/276	24.8	22.8	77.7	—	—	—	—
			286/277	49.6	45.6	155.4	—	057	057	057
			287/278	74.4	68.3	233.1	057	057	057	057

See Legend and Notes on page 86.



50HC17-28 ELECTRIC HEAT ELECTRICAL DATA — WITHOUT EnergyX (cont)**

50HC UNIT TYPE	NOMINAL V-Ph-Hz	IFM TYPE	ELECTRIC HEATER PART NUMBER CRHEATER***A00 (VERT./HORIZ.)	NOM. (kW)	APPLICATION (kW)	APPLICATION OUTPUT (MBH)	SINGLE POINT OR JUNCTION KIT PART NUMBER			
							NO C.O. OR UNPOWERED C.O.		WITH POWERED C.O.	
							NO P.E.	WITH P.E.	NO P.E.	WITH P.E.
50HC**24	208/203-3-60	STD	279/270	25.0	18.8/23.0	64.1/78.3	—	—	—	—
			280/271	50.0	37.6/45.9	128.1/156.7	056	056	056	056
			281/272	75.0	56.3/68.9	192.2/235.0	056	056	056	056
		MED-HE	279/270	25.0	18.8/23.0	64.1/78.3	—	—	—	—
			280/271	50.0	37.6/45.9	128.1/156.7	056	056	056	056
			281/272	75.0	56.3/68.9	192.2/235.0	056	056	056	056
		HIGH-HE	279/270	25.0	18.8/23.0	64.1/78.3	—	056	—	056
			280/271	50.0	37.6/45.9	128.1/156.7	056	056	056	056
			281/272	75.0	56.3/68.9	192.2/235.0	056	056	056	056
	460-3-60	STD	282/273	25.0	23.0	78.3	—	—	—	—
			283/274	50.0	45.9	156.7	057	057	057	057
			284/275	75.0	68.9	235.0	057	057	057	057
		MED-HE	282/273	25.0	23.0	78.3	—	—	—	—
			283/274	50.0	45.9	156.7	057	057	057	057
			284/275	75.0	68.9	235.0	057	057	057	057
		HIGH-HE	282/273	25.0	23.0	78.3	—	—	—	—
			283/274	50.0	45.9	156.7	057	057	057	057
			284/275	75.0	68.9	235.0	057	057	057	057
	575-3-60	STD	285/276	24.8	22.8	77.7	—	—	—	—
			286/277	49.6	45.6	155.4	—	057	—	057
			287/278	74.4	68.3	233.1	057	057	057	057
		MED-HE	285/276	24.8	22.8	77.7	—	—	—	—
			286/277	49.6	45.6	155.4	—	057	057	057
			287/278	74.4	68.3	233.1	057	057	057	057
HIGH-HE		285/276	24.8	22.8	77.7	—	—	—	—	
		286/277	49.6	45.6	155.4	057	057	057	057	
		287/278	74.4	68.3	233.1	057	057	057	057	
50HC**28	208/230-3-60	STD	279/270	25.0	18.8/23.0	64.1/78.3	056	056	056	056
			280/271	50.0	37.6/45.9	128.1/156.7	056	056	056	056
			281/272	75.0	56.3/68.9	192.2/235.0	056	056	056	056
		MED-HE	279/270	25.0	18.8/23.0	64.1/78.3	056	056	056	056
			280/271	50.0	37.6/45.9	128.1/156.7	056	056	056	056
			281/272	75.0	56.3/68.9	192.2/235.0	056	056	056	056
		HIGH-HE	279/270	25.0	18.8/23.0	64.1/78.3	056	056	056	056
			280/271	50.0	37.6/45.9	128.1/156.7	056	056	056	056
			281/272	75.0	56.3/68.9	192.2/235.0	056	056	056	056
	460-3-60	STD	282/273	25.0	23.0	78.3	—	—	—	—
			283/274	50.0	45.9	156.7	057	057	057	057
			284/275	75.0	68.9	235.0	057	057	057	057
		MED-HE	282/273	25.0	23.0	78.3	—	—	—	—
			283/274	50.0	45.9	156.7	057	057	057	057
			284/275	75.0	68.9	235.0	057	057	057	057
		HIGH-HE	282/273	25.0	23.0	78.3	—	—	—	—
			283/274	50.0	45.9	156.7	057	057	057	057
			284/275	75.0	68.9	235.0	057	057	057	057
	575-3-60	STD	285/276	24.8	22.8	77.7	—	—	—	—
			286/277	49.6	45.6	155.4	—	057	—	057
			287/278	74.4	68.3	233.1	057	057	057	057
		MED-HE	285/276	24.8	22.8	77.7	—	—	—	—
			286/277	49.6	45.6	155.4	—	057	057	057
			287/278	74.4	68.3	233.1	057	057	057	057
HIGH-HE		285/276	24.8	22.8	77.7	—	—	—	—	
		286/277	49.6	45.6	155.4	057	057	057	057	
		287/278	74.4	68.3	233.1	057	057	057	057	

See Legend and Notes on page 86.

50HC**17-28 MCA MOCBP ELECTRICAL DATA — WITHOUT CONVENIENCE OUTLET OR UNPOWERED CONVENIENCE OUTLET (WITHOUT EnergyX)

50HC UNIT TYPE	NOM. V-Ph-Hz	IFM TYPE	ELECTRIC HEAT			NO CONVENIENCE OUTLET OR UNPOWERED CONVENIENCE OUTLET							
			PART NUMBER	NOM (kW)	FLA	NO POWER EXHAUST				WITH POWER EXHAUST			
						MCA	FUSE OR HACR BRKR	DISC. SIZE		MCA	FUSE OR HACR BRKR	DISC. SIZE	
			FLA	LRA					FLA			LRA	
50HC**17	208/230-3-60	STD	NONE	—	—	68.3	90	71	393	80.1	100	85	413
			CRHEATER279A00	18.8/25.0	52.1/60.1	74.5/84.5	90/90	71/78	393/393	89.3/99.3	100/100	85/91	413/413
			CRHEATER280A00	37.6/50.0	104.2/120.3	139.6/129.7	150/150	128/147	393/393	154.4/144.4	175/150	142/161	413/413
		CRHEATER281A00	56.3/75.0	156.4/180.4	165.8/189.8	175/200	188/216	393/393	180.5/204.5	200/225	202/230	413/413	
		MED	NONE	—	—	71.4	90	75	423	83.2	100	88	443
			CRHEATER279A00	18.8/25.0	52.1/60.1	78.4/88.4	90/90	75/81	423/423	93.1/103.1	100/110	88/95	443/443
			CRHEATER280A00	37.6/50.0	104.2/120.3	143.5/133.6	150/150	132/151	423/423	158.3/148.3	175/175	146/164	443/443
		CRHEATER281A00	56.3/75.0	156.4/180.4	169.7/193.7	200/225	192/220	423/423	184.4/208.4	200/225	206/233	443/443	
		HIGH	NONE	—	—	74.4/73.5	90/90	78/77	425	86.2/85.3	100/100	92/91	445
			CRHEATER279A00	18.8/25.0	52.1/60.1	82.1/91.0	90/100	78/84	425/425	96.9/105.8	100/110	92/97	445/445
			CRHEATER280A00	37.6/50.0	104.2/120.3	147.3/136.2	150/150	135/153	425/425	162.0/150.9	175/175	149/167	445/445
		CRHEATER281A00	56.3/75.0	156.4/180.4	173.4/196.3	200/225	196/222	425/425	188.2/211.0	200/225	209/236	445/445	
	460-3-60	STD	NONE	—	—	34.9	45	36	234	41.1	50	44	246
			CRHEATER282A00	25.0	30.1	41.9	45	39	234	49.6	50	46	246
			CRHEATER283A00	50.0	60.1	64.4	70	73	234	72.1	80	80	246
		CRHEATER284A00	75.0	90.2	94.5	100	108	234	102.2	110	115	246	
		MED	NONE	—	—	36.8	45	39	249	43.0	50	46	261
			CRHEATER282A00	25.0	30.1	44.3	45	41	249	52.0	60	48	261
			CRHEATER283A00	50.0	60.1	66.7	80	75	249	74.5	80	82	261
		CRHEATER284A00	75.0	90.2	96.8	100	110	249	104.6	110	117	261	
		HIGH	NONE	—	—	37.9	50	40	250	44.1	50	47	262
			CRHEATER282A00	25.0	30.1	45.6	50	42	250	53.4	60	49	262
			CRHEATER283A00	50.0	60.1	68.1	80	76	250	75.9	80	84	262
		CRHEATER284A00	75.0	90.2	98.2	100	111	250	106.0	125	118	262	
	575-3-60	STD	NONE	—	—	26.2	30	27	184	31.0	40	33	192
			CRHEATER285A00	24.8	23.9	33.4	35	31	184	39.4	40	36	192
			CRHEATER286A00	49.6	47.7	63.1	70	58	184	69.1	70	64	192
		CRHEATER287A00	74.4	71.6	75.1	80	86	184	81.1	90	91	192	
		MED	NONE	—	—	26.2	30	27	184	31.0	40	33	192
			CRHEATER285A00	24.8	23.9	33.4	35	31	184	39.4	40	36	192
			CRHEATER286A00	49.6	47.7	63.1	70	58	184	69.1	70	64	192
		CRHEATER287A00	74.4	71.6	75.1	80	86	184	81.1	90	91	192	
		HIGH	NONE	—	—	29.0	35	31	198	33.8	40	36	206
			CRHEATER285A00	24.8	23.9	36.9	40	34	198	42.9	45	39	206
			CRHEATER286A00	49.6	47.7	66.6	70	61	198	72.6	80	67	206
		CRHEATER287A00	74.4	71.6	78.6	90	89	198	84.6	90	94	206	

See Legend and Notes on page 86.



50HC17-28 MCA MOCPELECTRICAL DATA — WITHOUT CONVENIENCE OUTLET OR UNPOWERED CONVENIENCE OUTLET (WITHOUT EnergyX) (cont)**

50HC UNIT TYPE	NOM. V-Ph-Hz	IFM TYPE	ELECTRIC HEAT			NO CONVENIENCE OUTLET OR UNPOWERED CONVENIENCE OUTLET							
			PART NUMBER	NOM (kW)	FLA	NO POWER EXHAUST				WITH POWER EXHAUST			
						MCA	FUSE OR HACR BRKR	DISC. SIZE		MCA	FUSE OR HACR BRKR	DISC. SIZE	
								FLA	LRA			FLA	LRA
50HC**20	208/230-3-60	STD	NONE	—	—	75.7	100	79	440	87.5	100	93	460
			CRHEATER279A00	18.8/25.0	52.1/60.1	77.9/87.9	100/100	79/81	440/440	92.6/102.6	100/110	93/94	460/460
			CRHEATER280A00	37.6/50.0	104.2/120.3	143.0/133.1	150/150	132/150	440/440	157.8/147.8	175/175	145/164	460/460
			CRHEATER281A00	56.3/75.0	156.4/180.4	169.2/193.2	200/225	192/219	440/440	183.9/207.9	200/225	205/233	460/460
		MED	NONE	—	—	79.1/78.2	100/100	83/82	455	90.9/90.0	100/100	97/96	475
			CRHEATER279A00	18.8/25.0	52.1/60.1	82.1/91.0	100/100	83/84	455/455	96.9/105.8	100/110	97/97	475/475
			CRHEATER280A00	37.6/50.0	104.2/120.3	147.3/136.2	150/150	135/153	455/455	162.0/150.9	175/175	149/167	475/475
			CRHEATER281A00	56.3/75.0	156.4/180.4	173.4/196.3	200/225	196/222	455/455	188.2/211.0	200/225	209/236	475/475
		HIGH-HE	NONE	—	—	82.6	100	87	451	94.4	110	101	471
			CRHEATER279A00	18.8/25.0	52.1/60.1	86.5/96.5	100/100	87/89	451/451	101.3/111.3	110/125	101/102	471/471
			CRHEATER280A00	37.6/50.0	104.2/120.3	151.6/141.7	175/175	139/158	451/451	166.4/156.4	175/175	153/172	471/471
			CRHEATER281A00	56.3/75.0	156.4/180.4	177.8/201.8	200/225	200/227	451/451	192.5/216.5	200/250	213/241	471/471
	460-3-60	STD	NONE	—	—	36.6	45	38	245	42.8	50	46	257
			CRHEATER282A00	25.0	30.1	43.6	45	40	245	51.4	60	47	257
			CRHEATER283A00	50.0	60.1	66.1	80	75	245	73.9	80	82	257
			CRHEATER284A00	75.0	90.2	96.2	100	109	245	104.0	110	116	257
		MED	NONE	—	—	38.2	50	40	252	44.4	50	47	264
			CRHEATER282A00	25.0	30.1	45.6	50	42	252	53.4	60	49	264
			CRHEATER283A00	50.0	60.1	68.1	80	76	252	75.9	80	84	264
			CRHEATER284A00	75.0	90.2	98.2	100	111	252	106.0	125	118	264
		HIGH-HE	NONE	—	—	40.4	50	43	250	46.6	50	50	262
			CRHEATER282A00	25.0	30.1	48.4	50	45	250	56.1	60	52	262
			CRHEATER283A00	50.0	60.1	70.9	80	79	250	78.6	80	86	262
			CRHEATER284A00	75.0	90.2	101.0	110	114	250	108.7	125	121	262
	575-3-60	STD	NONE	—	—	26.2	30	27	186	31.0	40	33	194
			CRHEATER285A00	24.8	23.9	33.4	35	31	186	39.4	40	36	194
			CRHEATER286A00	49.6	47.7	63.1	70	58	186	69.1	70	64	194
			CRHEATER287A00	74.4	71.6	75.1	80	86	186	81.1	90	91	194
		MED	NONE	—	—	29.0	35	31	200	33.8	40	36	208
			CRHEATER285A00	24.8	23.9	36.9	40	34	200	42.9	45	39	208
			CRHEATER286A00	49.6	47.7	66.6	70	61	200	72.6	80	67	208
			CRHEATER287A00	74.4	71.6	78.6	90	89	200	84.6	90	94	208
		HIGH-HE	NONE	—	—	31.0	40	33	198	35.8	45	38	206
			CRHEATER285A00	24.8	23.9	39.4	40	36	198	45.4	50	42	206
			CRHEATER286A00	49.6	47.7	69.1	70	64	198	75.1	80	69	206
			CRHEATER287A00	74.4	71.6	81.1	90	91	198	87.1	90	97	206

See Legend and Notes on page 86.

50HC**17-28 MCA MOCPELECTRICAL DATA — WITHOUT CONVENIENCE OUTLET OR UNPOWERED CONVENIENCE OUTLET (WITHOUT EnergyX) (cont)

50HC UNIT TYPE	NOM. V-Ph-Hz	IFM TYPE	ELECTRIC HEAT			NO CONVENIENCE OUTLET OR UNPOWERED CONVENIENCE OUTLET							
			PART NUMBER	NOM (kW)	FLA	NO POWER EXHAUST				WITH POWER EXHAUST			
						MCA	FUSE OR HACR BRKR	DISC. SIZE		MCA	FUSE OR HACR BRKR	DISC. SIZE	
								FLA	LRA			FLA	LRA
50HC**24	208/230-3-60	STD	NONE	—	—	86.6	100	91	574	98.4	125	105	594
			CRHEATER279A00	18.8/25.0	52.1/60.1	86.6/96.5	100/100	91/91	574/574	101.3/111.3	125/125	105/105	594/594
			CRHEATER280A00	37.6/50.0	104.2/120.3	151.6/141.7	175/175	139/158	574/574	166.4/156.4	175/175	153/172	594/594
		CRHEATER281A00	56.3/75.0	156.4/180.4	177.8/201.8	200/225	200/227	574/574	192.5/216.5	200/250	213/241	594/594	
		MED-HE	NONE	—	—	86.6	100	91	574	98.4	125	105	594
			CRHEATER279A00	18.8/25.0	52.1/60.1	86.6/96.5	100/100	91/91	574/574	101.3/111.3	125/125	105/105	594/594
			CRHEATER280A00	37.6/50.0	104.2/120.3	151.6/141.7	175/175	139/158	574/574	166.4/156.4	175/175	153/172	594/594
		CRHEATER281A00	56.3/75.0	156.4/180.4	177.8/201.8	200/225	200/227	574/574	192.5/216.5	200/250	213/241	594/594	
		HIGH-HE	NONE	—	—	98.0	125	105	653	109.8	125	118	673
			CRHEATER279A00	18.8/25.0	52.1/60.1	100.8/110.8	125/125	105/105	653/653	115.5/125.5	125/150	118/118	673/673
			CRHEATER280A00	37.6/50.0	104.2/120.3	165.9/155.9	175/175	153/171	653/653	180.6/170.7	200/175	166/185	673/673
		CRHEATER281A00	56.3/75.0	156.4/180.4	192.0/216.0	200/250	213/240	653/653	206.8/230.8	225/250	226/254	673/673	
	460-3-60	STD	NONE	—	—	45.3	50	48	310	51.5	60	55	322
			CRHEATER282A00	25.0	30.1	48.4	50	48	310	56.1	60	55	322
			CRHEATER283A00	50.0	60.1	70.9	80	79	310	78.6	80	86	322
		CRHEATER284A00	75.0	90.2	101.0	110	114	310	108.7	125	121	322	
		MED-HE	NONE	—	—	45.3	50	48	310	51.5	60	55	322
			CRHEATER282A00	25.0	30.1	48.4	50	48	310	56.1	60	55	322
			CRHEATER283A00	50.0	60.1	70.9	80	79	310	78.6	80	86	322
		CRHEATER284A00	75.0	90.2	101.0	110	114	310	108.7	125	121	322	
		HIGH-HE	NONE	—	—	51.0	60	54	350	57.2	70	62	362
			CRHEATER282A00	25.0	30.1	55.5	60	54	350	63.3	70	62	362
			CRHEATER283A00	50.0	60.1	78.0	90	86	350	85.7	90	93	362
		CRHEATER284A00	75.0	90.2	108.1	125	120	350	115.8	125	127	362	
	575-3-60	STD	NONE	—	—	33.4	40	35	232	38.2	45	41	240
			CRHEATER285A00	24.8	23.9	36.9	40	35	232	42.9	45	41	240
			CRHEATER286A00	49.6	47.7	66.6	70	61	232	72.6	80	67	240
		CRHEATER287A00	74.4	71.6	78.6	90	89	232	84.6	90	94	240	
MED-HE		NONE	—	—	35.4	45	37	230	40.2	50	43	238	
		CRHEATER285A00	24.8	23.9	39.4	45	37	230	45.4	50	43	238	
		CRHEATER286A00	49.6	47.7	69.1	70	64	230	75.1	80	69	238	
CRHEATER287A00		74.4	71.6	81.1	90	91	230	87.1	90	97	238		
HIGH-HE		NONE	—	—	37.3	45	40	257	42.1	50	45	265	
		CRHEATER285A00	24.8	23.9	41.8	45	40	257	47.8	50	45	265	
		CRHEATER286A00	49.6	47.7	71.5	80	66	257	77.5	80	71	265	
CRHEATER287A00		74.4	71.6	83.5	90	93	257	89.5	100	99	265		

See Legend and Notes on page 86.



50HC17-28 MCA MOCPELECTRICAL DATA — WITHOUT CONVENIENCE OUTLET OR UNPOWERED CONVENIENCE OUTLET (WITHOUT EnergyX) (cont)**

50HC UNIT TYPE	NOM. V-Ph-Hz	IFM TYPE	ELECTRIC HEAT			NO CONVENIENCE OUTLET OR UNPOWERED CONVENIENCE OUTLET							
			PART NUMBER	NOM (kW)	FLA	NO POWER EXHAUST				WITH POWER EXHAUST			
						MCA	FUSE OR HACR BRKR	DISC. SIZE		MCA	FUSE OR HACR BRKR	DISC. SIZE	
								FLA	LRA			FLA	LRA
50HC**28	208/230-3-60	STD	NONE	—	—	116.6/115.7	150/150	120/119	591	128.4/127.5	175/175	134/133	611
			CRHEATER279A00	18.8/25.0	52.1/60.1	116.6/115.7	150/150	120/119	591/591	128.4/127.5	175/175	134/133	611/611
			CRHEATER280A00	37.6/50.0	104.2/120.3	147.3/136.2	150/150	135/153	591/591	162.0/150.9	175/175	149/167	611/611
			CRHEATER281A00	56.3/75.0	156.4/180.4	173.4/196.3	200/225	196/222	591/591	188.2/211.0	200/225	209/236	611/611
		MED-HE	NONE	—	—	120.1	150	124	587	131.9	175	138	607
			CRHEATER279A00	18.8/25.0	52.1/60.1	120.1/120.1	150/150	124/124	587/587	131.9/131.9	175/175	138/138	607/607
			CRHEATER280A00	37.6/50.0	104.2/120.3	151.6/141.7	175/175	139/158	587/587	166.4/156.4	175/175	153/172	607/607
			CRHEATER281A00	56.3/75.0	156.4/180.4	177.8/201.8	200/225	200/227	587/587	192.5/216.5	200/250	213/241	607/607
		HIGH-HE	NONE	—	—	131.5	175	137	666	143.3	175	151	686
			CRHEATER279A00	18.8/25.0	52.1/60.1	131.5/131.5	175/175	137/137	666/666	143.3/143.3	175/175	151/151	686/686
			CRHEATER280A00	37.6/50.0	104.2/120.3	165.9/155.9	175/175	153/171	666/666	180.6/170.7	200/175	166/185	686/686
			CRHEATER281A00	56.3/75.0	156.4/180.4	192.0/216.0	200/250	213/240	666/666	206.8/230.8	225/250	226/254	686/686
	460-3-60	STD	NONE	—	—	51.1	60	53	321	57.3	70	60	333
			CRHEATER282A00	25.0	30.1	51.1	60	53	321	57.3	70	60	333
			CRHEATER283A00	50.0	60.1	68.1	80	76	321	75.9	80	84	333
			CRHEATER284A00	75.0	90.2	98.2	100	111	321	106.0	125	118	333
		MED-HE	NONE	—	—	53.3	60	56	319	59.5	70	63	331
			CRHEATER282A00	25.0	30.1	53.3	60	56	319	59.5	70	63	331
			CRHEATER283A00	50.0	60.1	70.9	80	79	319	78.6	80	86	331
			CRHEATER284A00	75.0	90.2	101.0	110	114	319	108.7	125	121	331
		HIGH-HE	NONE	—	—	59.0	70	62	359	65.2	80	70	371
			CRHEATER282A00	25.0	30.1	59.0	70	62	359	65.2	80	70	371
			CRHEATER283A00	50.0	60.1	78.0	90	86	359	85.7	90	93	371
			CRHEATER284A00	75.0	90.2	108.1	125	120	359	115.8	125	127	371
	575-3-60	STD	NONE	—	—	40.5	50	42	256	45.3	50	48	264
			CRHEATER285A00	24.8	23.9	40.5	50	42	256	45.3	50	48	264
			CRHEATER286A00	49.6	47.7	66.6	70	61	256	72.6	80	67	264
			CRHEATER287A00	74.4	71.6	78.6	90	89	256	84.6	90	94	264
		MED-HE	NONE	—	—	42.5	50	45	254	47.3	60	50	262
			CRHEATER285A00	24.8	23.9	42.5	50	45	254	47.3	60	50	262
			CRHEATER286A00	49.6	47.7	69.1	70	64	254	75.1	80	69	262
			CRHEATER287A00	74.4	71.6	81.1	90	91	254	87.1	90	97	262
		HIGH-HE	NONE	—	—	44.4	50	47	281	49.2	60	52	289
			CRHEATER285A00	24.8	23.9	44.4	50	47	281	49.2	60	52	289
			CRHEATER286A00	49.6	47.7	71.5	80	66	281	77.5	80	71	289
			CRHEATER287A00	74.4	71.6	83.5	90	93	281	89.5	100	99	289

See Legend and Notes on page 86.

Electrical data (cont)



50HC**17-28 MCA MOCP ELECTRICAL DATA — WITH POWERED CONVENIENCE OUTLET (WITHOUT EnergyX)

50HC UNIT TYPE	NOM. V-Ph-Hz	IFM TYPE	ELECTRIC HEAT			WITH POWERED CONVENIENCE OUTLET							
			PART NUMBER	NOM (kW)	FLA	NO POWER EXHAUST				WITH POWER EXHAUST			
						MCA	FUSE OR HACR BRKR	DISC. SIZE		MCA	FUSE OR HACR BRKR	DISC. SIZE	
								FLA	LRA			FLA	LRA
50HC**17	208/230-3-60	STD	NONE	—	—	73.1	90	77	398	84.9	100	90	418
			CRHEATER279A00	18.8/25.0	52.1/60.1	80.5/90.5	90/100	77/83	398/398	95.3/105.3	100/110	90/97	418/418
			CRHEATER280A00	37.6/50.0	104.2/120.3	145.6/135.7	150/150	134/152	398/398	160.4/150.4	175/175	148/166	418/418
		CRHEATER281A00	56.3/75.0	156.4/180.4	171.8/195.8	200/225	194/222	398/398	186.5/210.5	200/225	208/235	418/418	
		MED	NONE	—	—	76.2	100	80	428	88.0	100	94	448
			CRHEATER279A00	18.8/25.0	52.1/60.1	84.4/94.4	100/100	80/87	428/428	99.1/109.1	100/110	94/100	448/448
			CRHEATER280A00	37.6/50.0	104.2/120.3	149.5/139.6	150/150	138/156	428/428	164.3/154.3	175/175	151/170	448/448
		CRHEATER281A00	56.3/75.0	156.4/180.4	175.7/199.7	200/225	198/225	428/428	190.4/214.4	200/225	211/239	448/448	
		HIGH	NONE	—	—	79.2/78.3	100/100	84/83	430	91.0/90.1	100/100	97/96	450
			CRHEATER279A00	18.8/25.0	52.1/60.1	88.1/97.0	100/100	84/89	430/430	102.9/111.8	110/125	97/103	450/450
			CRHEATER280A00	37.6/50.0	104.2/120.3	153.3/142.2	175/175	141/158	430/430	168.0/156.9	175/175	155/172	450/450
		CRHEATER281A00	56.3/75.0	156.4/180.4	179.4/202.3	200/225	201/228	430/430	194.2/217.0	200/250	215/241	450/450	
	460-3-60	STD	NONE	—	—	37.1	45	39	236	43.3	50	46	248
			CRHEATER282A00	25.0	30.1	44.6	45	41	236	52.4	60	48	248
			CRHEATER283A00	50.0	60.1	67.1	70	76	236	74.9	80	83	248
		CRHEATER284A00	75.0	90.2	97.2	100	110	236	105.0	110	117	248	
		MED	NONE	—	—	39.0	50	41	251	45.2	50	48	263
			CRHEATER282A00	25.0	30.1	47.0	50	43	251	54.8	60	50	263
			CRHEATER283A00	50.0	60.1	69.5	80	78	251	77.2	80	85	263
		CRHEATER284A00	75.0	90.2	99.6	110	112	251	107.3	125	119	263	
		HIGH	NONE	—	—	40.1	50	42	252	46.3	50	50	264
			CRHEATER282A00	25.0	30.1	48.4	50	45	252	56.1	60	52	264
			CRHEATER283A00	50.0	60.1	70.9	80	79	252	78.6	80	86	264
		CRHEATER284A00	75.0	90.2	101.0	110	114	252	108.7	125	121	264	
	575-3-60	STD	NONE	—	—	27.9	35	29	186	32.7	40	35	194
			CRHEATER285A00	24.8	23.9	35.5	40	33	186	41.5	45	38	194
			CRHEATER286A00	49.6	47.7	65.3	70	60	186	71.3	80	66	194
		CRHEATER287A00	74.4	71.6	77.2	80	88	186	83.2	90	93	194	
		MED	NONE	—	—	27.9	35	29	186	32.7	40	35	194
			CRHEATER285A00	24.8	23.9	35.5	40	33	186	41.5	45	38	194
			CRHEATER286A00	49.6	47.7	65.3	70	60	186	71.3	80	66	194
		CRHEATER287A00	74.4	71.6	77.2	80	88	186	83.2	90	93	194	
		HIGH	NONE	—	—	30.7	40	33	200	35.5	45	38	208
			CRHEATER285A00	24.8	23.9	39.0	40	36	200	45.0	50	41	208
			CRHEATER286A00	49.6	47.7	68.8	70	63	200	74.8	80	69	208
		CRHEATER287A00	74.4	71.6	80.7	90	91	200	86.7	90	96	208	

See Legend and Notes on page 86.



50HC17-28 MCA MOCP ELECTRICAL DATA — WITH POWERED CONVENIENCE OUTLET
(WITHOUT EnergyX) (cont)**

50HC UNIT TYPE	NOM. V-Ph-Hz	IFM TYPE	ELECTRIC HEAT			WITH POWERED CONVENIENCE OUTLET							
			PART NUMBER	NOM (kW)	FLA	NO POWER EXHAUST				WITH POWER EXHAUST			
						MCA	FUSE OR HACR BRKR	DISC. SIZE		MCA	FUSE OR HACR BRKR	DISC. SIZE	
								FLA	LRA			FLA	LRA
50HC**20	208/230-3-60	STD	NONE	—	—	80.5	100	85	445	92.3	100	98	465
			CRHEATER279A00	18.8/25.0	52.1/60.1	83.9/93.9	100/100	85/86	445/445	98.6/108.6	100/110	98/100	465/465
			CRHEATER280A00	37.6/50.0	104.2/120.3	149.0/139.1	150/150	137/156	445/445	163.8/153.8	175/175	151/169	465/465
			CRHEATER281A00	56.3/75.0	156.4/180.4	175.2/199.2	200/225	197/225	445/445	189.9/213.9	200/225	211/238	465/465
		MED	NONE	—	—	83.9/83.0	100/100	89/88	460	95.7/94.8	110/110	102/101	480
			CRHEATER279A00	18.8/25.0	52.1/60.1	88.1/97.0	100/100	89/89	460/460	102.9/111.8	110/125	102/103	480/480
			CRHEATER280A00	37.6/50.0	104.2/120.3	153.3/142.2	175/175	141/158	460/460	168.0/156.9	175/175	155/172	480/480
			CRHEATER281A00	56.3/75.0	156.4/180.4	179.4/202.3	200/225	201/228	460/460	194.2/217.0	200/250	215/241	480/480
		HIGH-HE	NONE	—	—	87.4	100	93	456	99.2	125	106	476
			CRHEATER279A00	18.8/25.0	52.1/60.1	92.5/102.5	100/110	93/94	456/456	107.3/117.3	125/125	106/108	476/476
			CRHEATER280A00	37.6/50.0	104.2/120.3	157.6/147.7	175/175	145/164	456/456	172.4/162.4	175/175	159/177	476/476
			CRHEATER281A00	56.3/75.0	156.4/180.4	183.8/207.8	200/225	205/233	456/456	198.5/222.5	200/250	219/246	476/476
	460-3-60	STD	NONE	—	—	38.8	50	41	247	45.0	50	48	259
			CRHEATER282A00	25.0	30.1	46.4	50	43	247	54.1	60	50	259
			CRHEATER283A00	50.0	60.1	68.9	80	77	247	76.6	80	84	259
			CRHEATER284A00	75.0	90.2	99.0	100	112	247	106.7	110	119	259
		MED	NONE	—	—	40.4	50	43	254	46.6	50	50	266
			CRHEATER282A00	25.0	30.1	48.4	50	45	254	56.1	60	52	266
			CRHEATER283A00	50.0	60.1	70.9	80	79	254	78.6	80	86	266
			CRHEATER284A00	75.0	90.2	101.0	110	114	254	108.7	125	121	266
		HIGH-HE	NONE	—	—	42.6	50	45	252	48.8	60	52	264
			CRHEATER282A00	25.0	30.1	51.1	60	47	252	58.9	60	54	264
			CRHEATER283A00	50.0	60.1	73.6	80	82	252	81.4	90	89	264
			CRHEATER284A00	75.0	90.2	103.7	125	116	252	111.5	125	123	264
575-3-60	STD	NONE	—	—	27.9	35	29	188	32.7	40	35	196	
		CRHEATER285A00	24.8	23.9	35.5	40	33	188	41.5	45	38	196	
		CRHEATER286A00	49.6	47.7	65.3	70	60	188	71.3	80	66	196	
		CRHEATER287A00	74.4	71.6	77.2	80	88	188	83.2	90	93	196	
	MED	NONE	—	—	30.7	40	33	202	35.5	45	38	210	
		CRHEATER285A00	24.8	23.9	39.0	40	36	202	45.0	50	41	210	
		CRHEATER286A00	49.6	47.7	68.8	70	63	202	74.8	80	69	210	
		CRHEATER287A00	74.4	71.6	80.7	90	91	202	86.7	90	96	210	
	HIGH-HE	NONE	—	—	32.7	40	35	200	37.5	45	40	208	
		CRHEATER285A00	24.8	23.9	41.5	45	38	200	47.5	50	44	208	
		CRHEATER286A00	49.6	47.7	71.3	80	66	200	77.3	80	71	208	
		CRHEATER287A00	74.4	71.6	83.2	90	93	200	89.2	90	99	208	

See Legend and Notes on page 86.

50HC**17-28 MCA MOCP ELECTRICAL DATA — WITH POWERED CONVENIENCE OUTLET (WITHOUT EnergyX) (cont)

50HC UNIT TYPE	NOM. V-Ph-Hz	IFM TYPE	ELECTRIC HEAT			WITH POWERED CONVENIENCE OUTLET							
			PART NUMBER	NOM (kW)	FLA	NO POWER EXHAUST				WITH POWER EXHAUST			
						MCA	FUSE OR HACR BRKR	DISC. SIZE		MCA	FUSE OR HACR BRKR	DISC. SIZE	
								FLA	LRA			FLA	LRA
50HC**24	208/230-3-60	STD	NONE	—	—	91.4	100	97	579	103.2	125	111	599
			CRHEATER279A00	18.8/25.0	52.1/60.1	92.5/102.5	100/110	97/97	579/579	107.3/117.3	125/125	111/111	599/599
			CRHEATER280A00	37.6/50.0	104.2/120.3	157.6/147.7	175/175	145/164	579/579	172.4/162.4	175/175	159/177	599/599
			CRHEATER281A00	56.3/75.0	156.4/180.4	183.8/207.8	200/225	205/233	579/579	198.5/222.5	200/250	219/246	599/599
		MED-HE	NONE	—	—	91.4	100	97	579	103.2	125	111	599
			CRHEATER279A00	18.8/25.0	52.1/60.1	92.5/102.5	100/110	97/97	579/579	107.3/117.3	125/125	111/111	599/599
			CRHEATER280A00	37.6/50.0	104.2/120.3	157.6/147.7	175/175	145/164	579/579	172.4/162.4	175/175	159/177	599/599
			CRHEATER281A00	56.3/75.0	156.4/180.4	183.8/207.8	200/225	205/233	579/579	198.5/222.5	200/250	219/246	599/599
		HIGH-HE	NONE	—	—	102.8	125	110	658	114.6	125	124	678
			CRHEATER279A00	18.8/25.0	52.1/60.1	106.8/116.8	125/125	110/110	658/658	121.5/131.5	125/150	124/124	678/678
			CRHEATER280A00	37.6/50.0	104.2/120.3	171.9/161.9	175/175	158/177	658/658	186.6/176.7	200/200	172/190	678/678
			CRHEATER281A00	56.3/75.0	156.4/180.4	198.0/222.0	225/250	218/246	658/658	212.8/236.8	225/250	232/259	678/678
	460-3-60	STD	NONE	—	—	47.5	60	50	312	53.7	60	58	324
			CRHEATER282A00	25.0	30.1	51.1	60	50	312	58.9	60	58	324
			CRHEATER283A00	50.0	60.1	73.6	80	82	312	81.4	90	89	324
			CRHEATER284A00	75.0	90.2	103.7	125	116	312	111.5	125	123	324
		MED-HE	NONE	—	—	47.5	60	50	312	53.7	60	58	324
			CRHEATER282A00	25.0	30.1	51.1	60	50	312	58.9	60	58	324
			CRHEATER283A00	50.0	60.1	73.6	80	82	312	81.4	90	89	324
			CRHEATER284A00	75.0	90.2	103.7	125	116	312	111.5	125	123	324
		HIGH-HE	NONE	—	—	53.2	60	57	352	59.4	70	64	364
			CRHEATER282A00	25.0	30.1	58.3	60	57	352	66.0	70	64	364
			CRHEATER283A00	50.0	60.1	80.7	90	88	352	88.5	100	95	364
			CRHEATER284A00	75.0	90.2	110.8	125	123	352	118.6	125	130	364
575-3-60	STD	NONE	—	—	35.1	45	37	234	39.9	50	43	242	
		CRHEATER285A00	24.8	23.9	39.0	45	37	234	45.0	50	43	242	
		CRHEATER286A00	49.6	47.7	68.8	70	63	234	74.8	80	69	242	
		CRHEATER287A00	74.4	71.6	80.7	90	91	234	86.7	90	96	242	
	MED-HE	NONE	—	—	37.1	45	39	232	41.9	50	45	240	
		CRHEATER285A00	24.8	23.9	41.5	45	39	232	47.5	50	45	240	
		CRHEATER286A00	49.6	47.7	71.3	80	66	232	77.3	80	71	240	
		CRHEATER287A00	74.4	71.6	83.2	90	93	232	89.2	90	99	240	
	HIGH-HE	NONE	—	—	39.0	50	42	259	43.8	50	47	267	
		CRHEATER285A00	24.8	23.9	43.9	50	42	259	49.9	50	47	267	
		CRHEATER286A00	49.6	47.7	73.6	80	68	259	79.6	80	73	267	
		CRHEATER287A00	74.4	71.6	85.6	90	95	259	91.6	100	101	267	

See Legend and Notes on page 86.



50HC17-28 MCA MOCP ELECTRICAL DATA — WITH POWERED CONVENIENCE OUTLET
(WITHOUT EnergyX) (cont)**

50HC UNIT TYPE	NOM. V-Ph-Hz	IFM TYPE	ELECTRIC HEAT			WITH POWERED CONVENIENCE OUTLET							
			PART NUMBER	NOM (kW)	FLA	NO POWER EXHAUST				WITH POWER EXHAUST			
						MCA	FUSE OR HACR BRKR	DISC. SIZE		MCA	FUSE OR HACR BRKR	DISC. SIZE	
								FLA	LRA			FLA	LRA
50HC**28	208/230-3-60	STD	NONE	—	—	121.4/120.5	150/150	126/125	596	133.2/132.3	175/175	139/138	616
			CRHEATER279A00	18.8/25.0	52.1/60.1	121.4/120.5	150/150	126/125	596/596	133.2/132.3	175/175	139/138	616/616
			CRHEATER280A00	37.6/50.0	104.2/120.3	153.3/142.2	175/175	141/158	596/596	168.0/156.9	175/175	155/172	616/616
			CRHEATER281A00	56.3/75.0	156.4/180.4	179.4/202.3	200/225	201/228	596/596	194.2/217.0	200/250	215/241	616/616
		MED-HE	NONE	—	—	124.9	150	130	592	136.7	175	143	612
			CRHEATER279A00	18.8/25.0	52.1/60.1	124.9/124.9	150/150	130/130	592/592	136.7/136.7	175/175	143/143	612/612
			CRHEATER280A00	37.6/50.0	104.2/120.3	157.6/147.7	175/175	145/164	592/592	172.4/162.4	175/175	159/177	612/612
			CRHEATER281A00	56.3/75.0	156.4/180.4	183.8/207.8	200/225	205/233	592/592	198.5/222.5	200/250	219/246	612/612
		HIGH-HE	NONE	—	—	136.3	175	143	671	148.1	175	157	691
			CRHEATER279A00	18.8/25.0	52.1/60.1	136.3/136.3	175/175	143/143	671/671	148.1/148.1	175/175	157/157	691/691
			CRHEATER280A00	37.6/50.0	104.2/120.3	171.9/161.9	175/175	158/177	671/671	186.6/176.7	200/200	172/190	691/691
			CRHEATER281A00	56.3/75.0	156.4/180.4	198.0/222.0	225/250	218/246	671/671	212.8/236.8	225/250	232/259	691/691
	460-3-60	STD	NONE	—	—	53.3	60	56	323	59.5	70	63	335
			CRHEATER282A00	25.0	30.1	53.3	60	56	323	59.5	70	63	335
			CRHEATER283A00	50.0	60.1	70.9	80	79	323	78.6	80	86	335
			CRHEATER284A00	75.0	90.2	101.0	110	114	323	108.7	125	121	335
		MED-HE	NONE	—	—	55.5	70	58	321	61.7	80	66	333
			CRHEATER282A00	25.0	30.1	55.5	70	58	321	61.7	80	66	333
			CRHEATER283A00	50.0	60.1	73.6	80	82	321	81.4	90	89	333
			CRHEATER284A00	75.0	90.2	103.7	125	116	321	111.5	125	123	333
		HIGH-HE	NONE	—	—	61.2	70	65	361	67.4	80	72	373
			CRHEATER282A00	25.0	30.1	61.2	70	65	361	67.4	80	72	373
			CRHEATER283A00	50.0	60.1	80.7	90	88	361	88.5	100	95	373
			CRHEATER284A00	75.0	90.2	110.8	125	123	361	118.6	125	130	373
	575-3-60	STD	NONE	—	—	42.2	50	44	258	47.0	60	50	266
			CRHEATER285A00	24.8	23.9	42.2	50	44	258	47.0	60	50	266
			CRHEATER286A00	49.6	47.7	68.8	70	63	258	74.8	80	69	266
			CRHEATER287A00	74.4	71.6	80.7	90	91	258	86.7	90	96	266
		MED-HE	NONE	—	—	44.2	50	47	256	49.0	60	52	264
			CRHEATER285A00	24.8	23.9	44.2	50	47	256	49.0	60	52	264
			CRHEATER286A00	49.6	47.7	71.3	80	66	256	77.3	80	71	264
			CRHEATER287A00	74.4	71.6	83.2	90	93	256	89.2	90	99	264
		HIGH-HE	NONE	—	—	46.1	60	49	283	50.9	60	54	291
			CRHEATER285A00	24.8	23.9	46.1	60	49	283	50.9	60	54	291
			CRHEATER286A00	49.6	47.7	73.6	80	68	283	79.6	80	73	291
			CRHEATER287A00	74.4	71.6	85.6	90	95	283	91.6	100	101	291

See Legend and Notes on page 86.

Legend and Notes For Electrical Data Tables

LEGEND

C.O.	— Convenience Outlet
FLA	— Full Load Amps
HIGH-HE	— High-High Efficiency
IFM	— Indoor Fan Motor
LRA	— Locked Rotor Amps
MCA	— Minimum Circuit Amps
MED-HE	— Medium-High Efficiency
NOM	— Nominal
P.E.	— Power Exhaust
RLA	— Rated Load Amps

NOTES:

1. Refer to Packaged Rooftop Builder (Selection Software) for additional electrical data with EnergyX system.
2. In compliance with NEC requirements for multi-motor and combination load equipment (refer to NEC Articles 430 and 440), the overcurrent protective device for the unit shall be fuse or HACR breaker. Canadian units may be fuse or circuit breaker.
3. For 208/230 v units, where one value is shown it is the same for either 208 or 230 volts.
4. **Unbalanced 3-Phase Supply Voltage**
Never operate a motor where a phase imbalance in supply voltage is greater than 2%. Use the following formula to determine the percentage of voltage imbalance.

$$\% \text{ Voltage Imbalance} = 100 \times \frac{\text{max voltage deviation from average voltage}}{\text{average voltage}}$$

Example: Supply voltage is 230-3-60



AB = 224 v
BC = 231 v
AC = 226 v

$$\text{Average Voltage} = \frac{(224 + 231 + 226)}{3} = \frac{681}{3} = 227$$

Determine maximum deviation from average voltage.

(AB) 227-224 = 3 v

(BC) 231-227 = 4 v

(AC) 227-226 = 1 v

Maximum deviation is 4 v.

Determine percent of voltage imbalance.

$$\% \text{ Voltage Imbalance} = 100 \times \frac{4}{227} = 1.78\%$$

This amount of phase imbalance is satisfactory as it is below the maximum allowable 2%.

IMPORTANT: If the supply voltage phase imbalance is more than 2%, contact your local electric utility company immediately.

General

The sequence below describes the sequence of operation for an electro-mechanical unit with and without a factory-installed EconoMi\$er IV and X (called “economizer” in this sequence). For information regarding a direct digital controller, see the start-up, operations, and troubleshooting manual for the applicable controller.

Electro-Mechanical Units with No Economizer

Cooling (Single speed indoor fan motor)

When the thermostat calls for cooling, terminals G and Y1 are energized. As a result, the indoor-fan contactor (IFC) and the compressor contactor (C1) are energized, causing the indoor-fan motor (IFM), compressor #1, and outdoor fan to start. If the unit has 2 stages of cooling, the thermostat will additionally energize Y2. On two compressor units, the Y2 signal will energize compressor contactor #2 (C2), causing compressor #2 to start. The Y2 signal will energize the compressor loader plug, allowing compressor to operate at 100% capacity. Regardless of the number of stages, the outdoor-fan motor runs continuously while unit is cooling.

Cooling (2-speed indoor fan motor)

Per ASHRAE 90.1-2016 standard section 6.4.3.10.b, during the first stage of cooling operation the VFD will adjust the fan motor to provide 66% of the total cfm established for the unit. When a call for the second stage of cooling is required, the VFD will allow the total cfm established for the unit (100%).

Heating

NOTE: The 50HC unit is sold as cooling only. If electric heaters are required, use only factory-approved electric heaters. Electric heaters are available as a factory-installed option or a field-installed accessory for 50HC vertical airflow units. For 50HC horizontal airflow units and all 50HC units equipped with the EnergyX option electric heaters are available as a field-installed accessory only. They will operate as described below.

Units have either 1 or 2 stages of electric heat. When the thermostat calls for heating, power is applied to the W1 terminal at the unit. The unit control will energize the indoor fan contactor and the first stage of electric heat. On units with two-stage heating, when additional heating is required, the second stage of electric heat (if equipped) will be energized when power is applied at the W2 terminal on the unit.

Electro-Mechanical Units with an Economizer

Cooling

When free cooling is not available, the compressors will be controlled by the zone thermostat. When free cooling is available, the outdoor-air damper is modulated by the EconoMi\$er IV and X control to provide a 50°F (10°C) to 55°F (13°C) mixed-air temperature into the zone. As the mixed air temperature fluctuates above 55°F (13°C) or below 50°F (10°C), dampers will be modulated (open or close) to bring the mixed-air temperature back within control. If mechanical cooling is utilized with free cooling, the outdoor-air damper will maintain its current position at the time the compressor is started. If the increase in cooling capacity causes the mixed-air temperature to drop below 45°F (7°C), then the outdoor-air damper position will be decreased to the minimum position. If the mixed-air temperature continues to fall, the outdoor-air damper will

close. Control returns to normal once the mixed-air temperature rises above 48°F (9°C). The power exhaust fans will be energized and de-energized, if installed, as the outdoor-air damper opens and closes.

If field-installed accessory CO₂ sensors are connected to the EconoMi\$er IV and X control, a demand controlled ventilation strategy will begin to operate. As the CO₂ level in the zone increases above the CO₂ setpoint, the minimum position of the damper will be increased proportionally. As the CO₂ level decreases because of the increase in fresh air, the outdoor-air damper will be proportionally closed. For EconoMi\$er IV and X operation, there must be a thermostat call for the fan (G). If the unit is occupied and the fan is on, the damper will operate at minimum position. Otherwise, the damper will be closed.

When the EconoMi\$er IV and X control is in the occupied mode and a call for cooling exists (Y1 on the thermostat), the control will first check for indoor fan operation. If the fan is not on, then cooling will not be activated. If the fan is on, then the control will open the EconoMi\$er IV and X damper to the minimum position.

On the initial power to the EconoMi\$er IV and X control, it will take the damper up to 2¹/₂ minutes before it begins to position itself. After the initial power-up, further changes in damper position can take up to 30 seconds to initiate. Damper movement from full closed to full open (or vice versa) will take between 1¹/₂ and 2¹/₂ minutes. If free cooling can be used as determined from the appropriate changeover command (switch, dry bulb, enthalpy curve, differential dry bulb, or differential enthalpy), then the control will modulate the dampers open to maintain the mixed-air temperature setpoint at 50°F (10°C) to 55°F (13°C). If there is a further demand for cooling (cooling second stage - Y2 is energized), then the control will bring on compressor stage 1 to maintain the mixed-air temperature setpoint. The EconoMi\$er IV and X damper will be open at maximum position. EconoMi\$er IV and X operation is limited to a single compressor.

2-SPEED NOTE: When operating in ventilation mode only, the indoor fan motor will automatically adjust to 66% of the total cfm established.

Heating

The sequence of operation for the heating is the same as an electro-mechanical unit with no economizer. The only difference is how the economizer acts. The economizer will stay at the Economizer Minimum Position while the evaporator fan is operating. The outdoor-air damper is closed when the indoor fan is not operating.

Refer to Service and Maintenance Manual for further details.

Optional Humidi-MiZer® Dehumidification System

Units with the factory equipped Humidi-MiZer system option are capable of providing multiple modes of improved dehumidification as a variation of the normal cooling cycle. The Humidi-MiZer system option includes additional valves in the liquid line and discharge line of each refrigerant circuit, a small reheat condenser coil downstream of the evaporator, and Motormaster variable-speed control of some or all outdoor fans. Operation of the revised refrigerant circuit for each mode is described in the following.

The Humidi-MiZer system provides three sub-modes of operation: Cool, Reheat1, and Reheat2.

Sequence of operation (cont)



Cool Mode

Provides a normal ratio of Sensible and Latent Cooling effect from the evaporator coil.

Reheat1

Provides increased Latent Cooling while slightly reducing the Sensible Cooling effect.

Reheat2

Provides normal Latent Cooling but with null or minimum Sensible Cooling delivered to the space.

The Reheat1 and Reheat2 modes are available when the unit is not in a Heating mode and when the Low Ambient Lockout switch is closed.

See the following figures for diagrams depict piping for Single Stage cooling units.

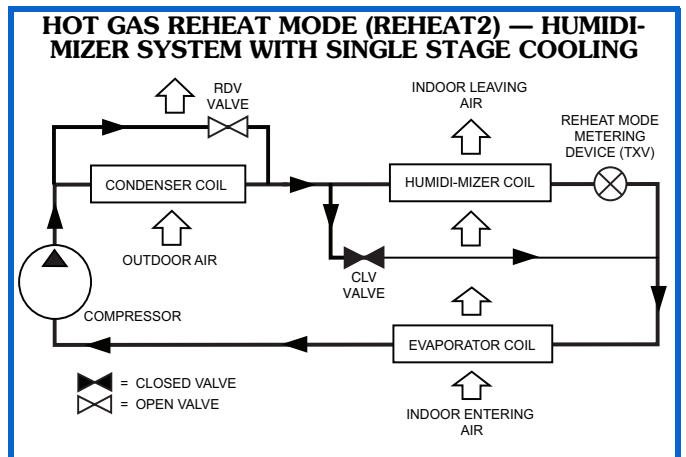
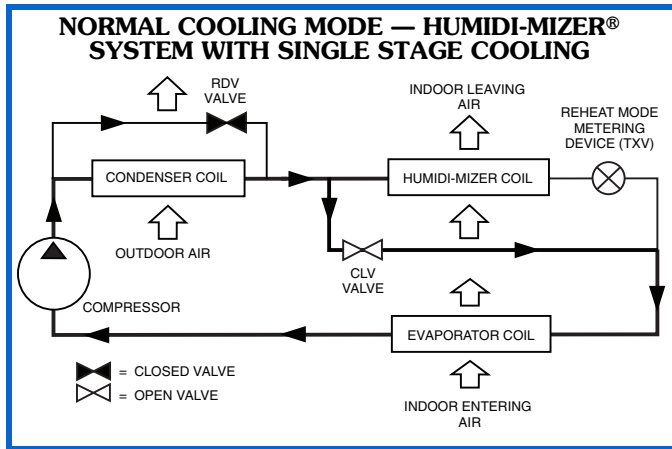
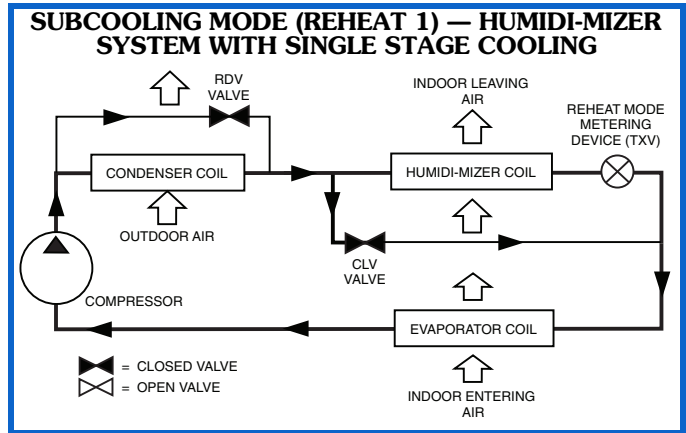

RTU Open Controller (Factory Option)

For details on operating 50HC units equipped with the factory-installed RTU Open controller option refer to Factory Installed RTU Open Multi-Protocol Controller Controls, Start-Up, Operation and Troubleshooting manual.

EnergyX® Sequence of Operation

The EnergyX Energy Recovery Ventilator (ERV) module is controlled by a digital controller located inside the EnergyX chassis. It communicates with the WeatherMaster® *ComfortLink* controller via a UPC translator module which connects to the WeatherMaster rooftop unit's *ComfortLink* controller via a LEN cable. All controller settings and configuration are input via the *ComfortLink* scrolling marquee display.

All control points, including outdoor airflow, exhaust airflow and CO₂ setpoints are configured via the *ComfortLink* scrolling marquee interface.

NOTE: CO₂ sensor requires a factory installed economizer.

The EnergyX energy recovery unit pre-conditions the outdoor air before it mixes with the return air and enters the rooftop unit evaporator coil. As a result, the EnergyX operation is mostly independent of the rooftop unit operation except to allow the space conditioning needs to be met without RTU compressor operation or RTU heat operation for a significantly wider range of ambient temperatures (than a unit without an energy recovery module). This is achieved either by the pre-conditioning of the EnergyX wheel or the economizer (if equipped). The EnergyX will pre-condition the outside air in the cooling and heating modes of operation.

General

The sequence below describes the sequence of operation for a WeatherMaster unit with *ComfortLink* controls and an EnergyX. For more information regarding controller operation, see the EnergyX Start-Up, Operations, and Troubleshooting supplement manual.

The EnergyX system will not activate unless the RTU fan is on. The EnergyX system default condition is to remain off in the unoccupied mode, however, this can be over-ridden via the control setpoints.

Cooling Operation

When the *ComfortLink* controller recognizes that the conditioned zone requires cooling (via the space temperature sensor or space thermostat) the EnergyX module is activated. The EnergyX control module follows the sequence of operation logic as listed below.

Step 1 — Economizer Operation

First, the EnergyX module checks if the outside air is suitable for free cooling via the outside air enthalpy sensor. If the outside air is suitable for free cooling and the unit has an economizer, the EnergyX will operate in "ventilation mode" where the wheel will remain off but the ERV economizer will modulate in free-cooling. If the unit is in Unoccupied mode, then the unit will not operate in economizer mode and will proceed to Step 2.

Step 2 — Wheel Operation

If the outside air is not suitable for free cooling, then the EnergyX module will operate in either cooling or heating mode as called for by the rooftop unit *ComfortLink* controller.

NOTE: If the unit is in Unoccupied mode, the default configuration is that the EnergyX module will not operate.

This can be over-ridden by an adjustable setpoint in the ERV controller.

Cooling Operation

If the outside air is not suitable for free cooling then the EnergyX wheel will activate and the supply fan will activate per the CFM setpoint.

Modulating EnergyX Units Only

If a CO₂ sensor is used (connected to the RTU *ComfortLink* controller) the supply fan will modulate between the DCV minimum and DCV maximum setpoints. The exhaust fan will modulate to follow the supply fan operation per the Exhaust CFM-offset value. If the economizer opens more than 5%, the wheel utilizes a "stop-jog" operation to periodically rotate the wheel and minimize potential dirt build-up and excess wear on one section of the wheel.

NOTE: CO₂ sensor requires a factory installed economizer.

Heating Operation

When the *ComfortLink* controller sees that the space requires heating via the space temperature sensor or when the thermostat or calls for heating, the EnergyX module is activated. The ERV wheel will rotate and the supply fan will activate per the CFM setpoint.

NOTE: Requires field-installed accessory electric heater(s).

Modulating EnergyX Units Only

If a CO₂ sensor is used (connected to the RTU *ComfortLink* controller) the supply fan will modulate between the DCV minimum and DCV maximum setpoints. The exhaust fan will modulate to follow the supply fan operation per the Exhaust CFM-offset value, via the Economizer Control Board (ECB).

Supply and Exhaust Air Frost Control Operation

When the factory-installed frost protection option is used, the EnergyX module will sense pressure differential across the energy recovery cassette. The supply blower will be shut-off if the pressure differential across the energy recovery cassette exceeds the adjustable setpoint value. The blower will remain off for 5 minutes. The exhaust blower and wheel will remain on, in order to remove any frost build-up on the wheel.

EnergyX Wheel Maintenance and Blower Indicator Operation

When the optional factory installed wheel maintenance indicator is used, a proxy sensor monitors the EnergyX wheel and sends a corresponding alarm signal when appropriate. Pressure switches are used to detect and activate the unit alarm when blowers are not running.

EnergyX Filter Maintenance Indicator Operation

When the optional factory-installed filter maintenance indicator is used, a factory-installed differential pressure switch measures pressure drop across the outside air filter and activates a field-supplied dry contact indicator when the pressure differential exceeds the adjustable switch setpoint. EnergyX operation is not interrupted.

Minimum Operating Ambient Temp (Cooling)

In mechanical cooling mode, your Carrier rooftop unit can safely operate down to an outdoor ambient temperature of 35°F (2°C). It is possible to provide cooling at lower outdoor ambient temperatures by using less outside air, economizers, and/or accessory low ambient kits.

Maximum Operating Ambient Temp (Cooling)

The maximum operating ambient temperature for cooling mode is 125°F (52°C). While cooling operation above 125°F (52°C) may be possible, it could cause either a reduction in performance, reliability, or a protective action by the unit's internal safety devices.

Minimum and Maximum Airflow (Cooling Mode)

To maintain safe and reliable operation of your rooftop, operate within the cooling airflow limits. Operating above the max may cause blow-off, undesired airflow noise, or airflow related problems with the rooftop unit. Operating below the min may cause problems with coil freeze-up. For proper minimum and maximum CFM values, see the Minimum-Maximum Airflow Ratings table on page 5.

Airflow

All units are draw-through in cooling mode.

Outdoor Air Application Strategies

Economizers reduce operating expenses and compressor run time by providing a free source of cooling and a means of ventilation to match application changing needs. In fact, they should be considered for most applications. Also consider the various economizer control methods and their benefits, as well as sensors required to accomplish your application goals. Please contact your local Carrier representative for assistance.

Motor Limits, Brake Horsepower (BHP)

Due to Carrier's internal unit design, air path, and specially designed motors, the full horsepower (maximum continuous BHP) band, as listed in the table on page 6, can be used with the utmost confidence. There is no need for extra safety factors, as Carrier's motors are designed and rigorously tested to use the entire, listed BHP range without either nuisance tripping or premature motor failure.

Sizing a Rooftop

Bigger isn't necessarily better. While an air conditioner needs to have enough capacity to meet the load, it doesn't need excess capacity. In fact, having excess capacity typically results in very poor part load performance and humidity control.

Using higher design temperatures than ASHRAE recommends for your location, adding "safety factors" to the calculated load, and rounding up to the next largest unit, are all signs of oversizing air conditioners. Oversizing can cause short-cycling, and short cycling leads to poor humidity control, reduced efficiency, higher utility bills, drastic indoor temperature swings, excessive noise, and increased wear and tear on the air conditioner.

Rather than oversizing an air conditioner, wise contractors and engineers "right-size" or even slightly undersize air conditioners. Correctly sizing an air conditioner controls

humidity better; promotes efficiency; reduces utility bills; extends equipment life, and maintains even, comfortable temperatures.

Low Ambient Applications

When equipped with a Carrier economizer, your rooftop unit can cool your space by bringing in fresh, cool outside air. In fact, when so equipped, accessory low-ambient kit may not be necessary. In low ambient conditions, unless the outdoor air is excessively humid or contaminated, economizer-based "free cooling" is the preferred less costly and energy conscious method.

In low ambient applications where outside air might not be desired (such as contaminated or excessively humid outdoor environments), your Carrier rooftop can operate to ambient temperatures down to -20°F (-29°C) using the recommended accessory Motormaster® low ambient controller.

Winter Start

Carrier's winter start kit extends the low ambient limit of your rooftop to 25°F (-4°C). The kit bypasses the low pressure switch, preventing nuisance tripping of the low pressure switch. Other low ambient precautions may still be prudent.

Staged Air Volume (SAV™) with Variable Frequency Drive (VFD)

Carrier's Staged Air Volume (SAV) system utilizes a Variable Frequency Drive (VFD) to automatically adjust the indoor fan motor speed in sequence with the units cooling operation. Per ASHRAE 90.1-2016 (American Society and IECC-2015 standards, during the first stage of cooling operation, the VFD will adjust the fan motor to provide 66% of the total cfm established for the unit. When a call for the second stage of cooling is required, the VFD will allow the total cfm for the unit established (100%). During the heating mode, the VFD will allow total design cfm (100%) operation and during the ventilation mode the VFD will allow operation to 66% of total cfm.

The VFD used in Carrier's SAV system has soft start capabilities to slowly ramp up the speeds, thus eliminating any high inrush air volume during initial start-up. It also has internal over current protection for the fan motor and a field-installed display kit that allows adjustment and in depth diagnostics of the VFD.

This SAV system is available on models with 2-stage cooling operation with electrical mechanical or RTU Open (multi Protocol) controls. Both space sensor and conventional thermostats controls can be used to provide accurate control in any application.

The SAV system is very flexible for initial fan performance set up and adjustment. The standard factory shipped VFD is pre-programmed to automatically stage the fan speed between the first and second stage of cooling. The unit fan performance static pressure and cfm can be easily adjusted using the traditional means of pulley adjustments. The other means to adjust the unit static and cfm performance is to utilize the field-installed display module and adjust the frequency and voltage in the VFD to required performance requirements. In either case, once set up the VFD will automatically adjust the speed between the cooling stage operations.

50HC STAGED AIR VOLUME (SAV) — VARIABLE FREQUENCY DRIVE (VFD) HP RATING

50HC UNIT	VOLTAGE	STATIC OPTION	VFD HP RATING
17	208/230, 460	STD	3.0
	575	STD	5.0
	208/230	MED	3.0
	460, 575	MED	5.0
	208/230, 460, 575	HIGH	7.5
20	208/230	STD	3.0
	460, 575	STD	5.0
	208/230, 460, 575	MED	7.5
	208/230, 460, 575	HIGH	7.5
24	208/230, 460, 575	STD	7.5
	208/230, 460, 575	MED	7.5
	208/230, 460, 575	HIGH	7.5
28	208/230, 460, 575	STD	7.5
	208/230, 460, 575	MED	7.5
	208/230, 460, 575	HIGH	7.5

Optional EnergyX System Application Data

Energy recovery devices such as the EnergyX typically result in substantial energy savings over other outdoor air devices. Specifically, the EnergyX adds sensible and latent capacity as well as additional stages of cooling and heating operation to the Rooftop Unit. Due to the EnergyX's significantly lower input watts than the corresponding RTU compressor(s), proper control strategies for this device maximize its operation to reduce the run time of the RTU compressor(s). This results in a much higher system efficiency than can typically be achieved by using a rooftop unit of the same total capacity.

The EnergyX with its modulating airflow capability allows a designer to increase the amount of outside air significantly more than normal with the following benefits:

- Reduced rooftop unit sizing - The more air that passes through the energy recovery device reduces the load (and potential unit size) on the rooftop unit's compressors and heating system
- Higher system cooling and heating efficiencies - Since the EnergyX uses the power of 'rotary enthalpy transfer' as opposed to mechanical compression conditioning of the ventilation air resulting in a much higher operating efficiency (RER) of the energy recovery unit and system Combined Efficiency Factor (CEF). The higher the airflow through the EnergyX, the higher the system efficiency (CEF) value. Since the EnergyX also conditions ventilation air in the heating mode, the necessary amount and/or operation of the rooftop unit heat system is reduced.
- Better part-load conditioning - as the EnergyX is able to modulate its airflow, the ability to match the changing zone part-load capacity (in cooling and in heating) is greatly increased.
- Higher air change rates - Larger amounts of ventilation air allows the zone air to be flushed out more often. This can contribute significantly to reduced sickness and more productive operating environments.

All ventilated spaces are good candidates for energy recovery systems. The applications that benefit most are those that require a large amount of outside air for a space that

has a low internal load. This is true because most outside air loads are latent which requires a larger rooftop unit to accommodate both internal and ventilation loads. Advantages of the ERV unit include the ability to reduce the size of the rooftop unit, provide better humidity levels and provide a stable, tempered space.

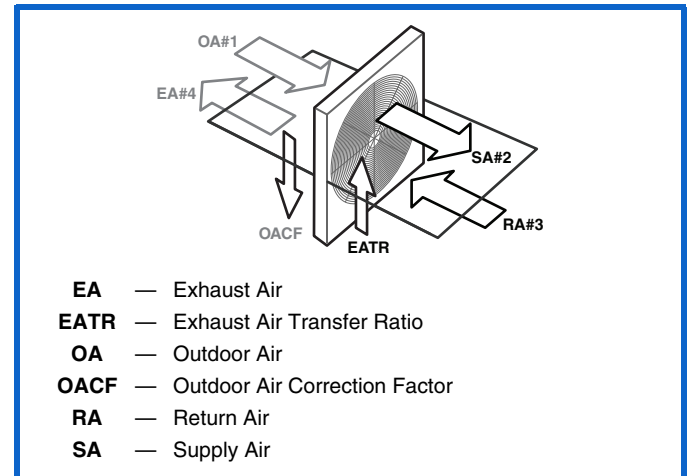

Examples of ERV applications are classrooms, churches, conference rooms, game rooms, auditoriums, movie theaters, day care centers, nursing homes, funeral homes, dormitories, and clinics. Retrofits of existing systems to handle outside air without modifying the rooftop unit are excellent applications. Other examples are bars, restaurants, casino/game rooms, barber/beauty shops, bingo halls, locker rooms, recreational facilities and health clubs. Animal shelters such as veterinary clinics and kennels have been very successful implementations. Retail spaces and manufacturing facilities are also good applications.

If the outside air requirement is greater than 10% of a rooftop unit's supply air rating the EnergyX unit should be considered to enhance the comfort of the occupants and reduce the tonnage of the rooftop unit. Carrier's Packaged RTU Builder selection software program offers a quick, simple look at the advantages and payback of the EnergyX system.

ASHRAE 62.1 Air Classification Requirements

The EnergyX system allows for easy compliance with the current ASHRAE Standard 62.1 Air Classification Requirements. Pollutant transfer via Desiccant is a 'non issue' since by virtue of the ASHRAE "classes of air" the main determinant is EATR or cross transfer of air by leakage from exhaust to supply. Since the EATR is an AHRI Certified measurement of an AHRI certified wheel device, the user can be assured of meeting the air dilution requirements of ASHRAE 62.1 and therefore the air classification requirements.

Industrial Applications are by definition those that are Class 4 air (or worse). Most wheel manufacturers do not encourage application of wheels to these types of applications. When required, many wheel manufacturers make specialty wheels with specific mechanical purge construction for industrial applications, that can be used to field-replace the factory provided wheels. Contact the applicable wheel manufacture for specific application details.

Choosing the proper airflow is essential. Unit selection guidance for the EnergyX system is in definite contrast to typical unit sizing and selections. Typical unit sizing methods are to select the energy recovery device per the desired

amount of outdoor air and then calculate the total capacity of the resulting energy recovery unit. This capacity is then subtracted from the desired total capacity for the conditioned zone. The remaining value is the necessary capacity of the rooftop unit. By conventional cooling and heating capacity guidance, the effort is to reduce the amount of outside (ventilation air) as much as possible since this additional ventilation air results in increased load on the rooftop unit compressor and heating sections.

NOTE: All units can be used in applications that require more or less airflow than the published CFM operating range as long as the airflow range is within the capabilities of the EnergyX fan system. This option can be used for high-static applications.

Although performance is optimized at equal exhaust and supply airflow rates, the selection program and the EnergyX unit can be used with unequal airflow amounts. The unit must be sized for the largest airflow amount. The smaller airflow used cannot be less than 50% of the larger airflow in the published range.

Energy Recovery Wheels

Carrier's EnergyX energy recovery wheels consist of a welded stainless steel hub, spoke and rim assembly, which is independent of the heat transfer matrix. The heat transfer matrix is contained in patented energy transfer segments, removable from the wheel without requiring tools. The energy wheel uses a unique parallel plate geometry and polymer film substrate to provide an optimized heat exchanger design. The polymer film construction is not subject to corrosion in coastal locations or swimming pool areas.

Silica Gel Technology

The EnergyX energy recovery wheels use the desiccant material known as silica gel, which is a highly porous solid adsorbent material that structurally resembles a rigid sponge. It has a very large internal surface composed of myriad microscopic cavities and a vast system of capillary channels that provide pathways connecting the internal microscopic cavities to the outside surface of the sponge. Silica gel enthalpy wheels transfer water by rotating between two air streams of different vapor pressures. The vapor pressure differential drives molecules into/from these cavities to transfer moisture from the more humid airstream to the drier airstream.

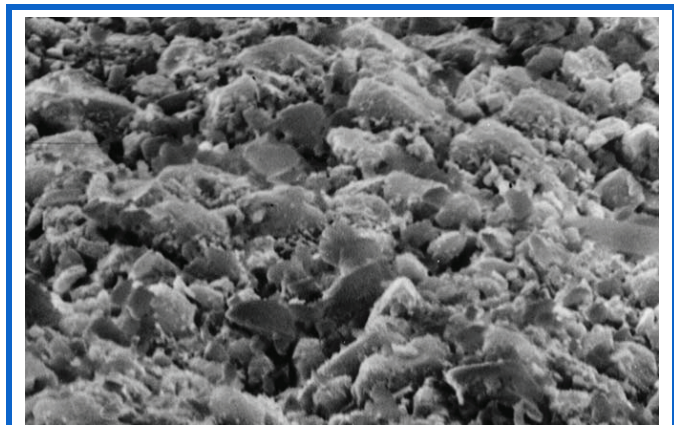

Microscopic Image of Silica Gel

Adsorption: Silica Gel vs. Molecular Sieve

The graph below shows the effect of Relative Humidity on Desiccant Capacity characteristic curve for adsorption of water on silica gel. It shows the percent weight adsorbed versus relative humidity of the airstream in contact with the silica gel. The amount of water adsorbed rises linearly with increasing relative humidity (RH) until RH reaches near 60%. It then plateaus at above 40% adsorbed as relative humidity approaches 100%. For contrast, the curve for molecular sieves rises rapidly to plateau at about 20% adsorbed at 20% RH.

The Effect of Relative Humidity on Desiccant Capacity graph explains the following application considerations:

- Molecular sieves are preferred for regenerated applications such as desiccant cooling and dehumidification systems that must reduce the processed air streams to very low relative humidities.
- Silica gel has superior characteristics for recovering space conditioning energy from exhaust air and handling high relative humidity outside conditions.

The transfer of water by adsorption/desorption is not dependent on temperature. Therefore, the silica gel enthalpy wheel works to reduce latent load at difficult part load conditions.

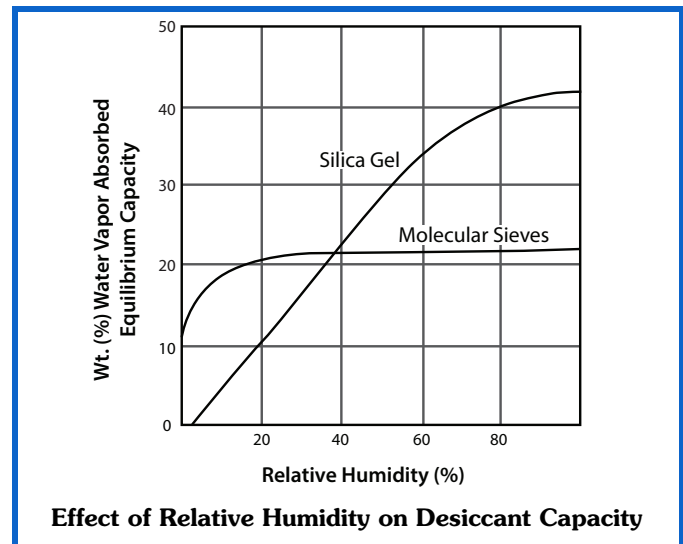

Fungal growth and moisture transfer

Carrier EnergyX units have silica gel-based desiccant wheels. The water molecules are individually transferred by desorption/adsorption to and from the silica gel surfaces. Water is present on the wheel in a molecular layer only, and condensation does not occur. Therefore, Carrier's energy recovery wheels experience dry moisture transfer; there is no bulk liquid water present that could support fungal growth. Water transfer to and from the wheel's desiccant surfaces occurs in the vapor phase; there are no wet surfaces and liquid water does not enter the airstream. Silica gel is also highly selective for water, based on the strong preference of the gel surface for the dipolar water molecule over other compounds.

Frost control requirements

Energy recovery systems require frost protection or a means of defrosting in climates that experience severe winter conditions. Frost formation results in a reduction and eventual blockage of airflow through the energy wheel.

Frost formation causes reduced airflow through the heat exchanger. Without frost control, energy recovery and airflow may be significantly reduced. The frost threshold temperature is the point at which frost begins to accumulate on heat exchanger surfaces. It is a function of both outside temperature and indoor relative humidity.

The Frost Threshold Comparison figure compares the frost threshold of a plate-type sensible heat exchanger with that of an enthalpy wheel. Note that frost forms at temperatures between 22°F and 30°F in a plate-type heat exchanger, frost threshold temperatures for enthalpy wheels are generally 20 to 30 degrees lower, approximately 0°F to 20°F. This is because the enthalpy wheel removes water from the exhaust air-stream, effectively lowering the exhausts dew point. The water removed is subsequently picked up through desorption by the entering outdoor air. Depending on the indoor relative humidity in areas where winter outside temperatures are between -5°F and 22°F, enthalpy wheel based recovery systems have a significant advantage over sensible plate type units because there is no additional cost for frost control. Even in cold areas, in most cases, enthalpy wheel based systems for schools and office buildings can be designed without frost control because most of the frosting hours are at night when the building is unoccupied. Consult bin data, such as that provided by ASHRAE, to qualify daytime applications in cold climates for frost-free operation.

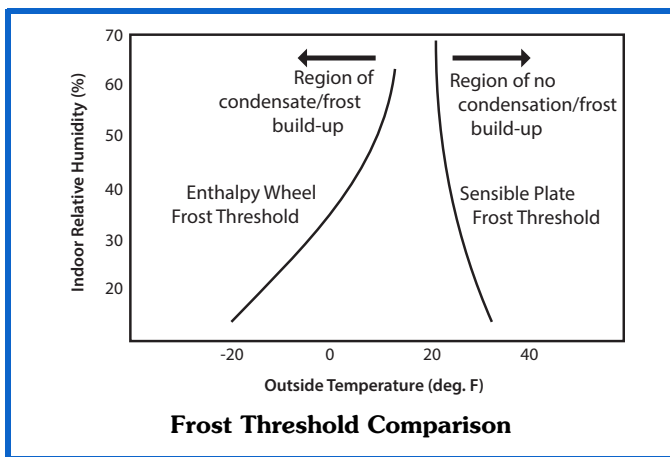

The Frost Thresholds Temperatures table below lists typical frost threshold temperatures for Carrier's EnergyX energy recovery wheels over a wide range of indoor-air temperatures and relative humidity. Frost control is not required until outdoor air temperatures are below the threshold.

INDOOR AIR RELATIVE HUMIDITY (%)	INDOOR AIR DRY BULB TEMPERATURE			
	70°F	72°F	75°F	80°F
20	-14	-13	-11	-8
30	-3	-2	-1	3
40	5	7	9	11
50	12	13	15	18
60	18	19	21	26

In regions where winter temperatures are extreme, Carrier's energy recovery wheels can be used effectively with the Frost Protection Factory Installed Option (FIOP).

NOTE: Refer to ASHRAE for bin data in cold climates where the threat of wheel frosting is frequent. Consult this information to ensure appropriate preheat techniques are used during occupied times.

Frost prevention for frost control is required in extremely cold climates to preserve performance and assure the continuous supply of outdoor air. Enthalpy wheel frost control strategies take advantage of inherently low frosting thresholds. This results in minimized energy use and maximized design load reductions. In regions that experience extreme winter conditions, the Frost Protection FIOP allows the exhaust fan to operate below the frost threshold temperature; however, a temperature sensor would disable the supply fan when the outdoor-air temperatures reach the frost control setpoint. The outdoor-air temperature sensor is located in the outdoor air intake of the ERV section. To avoid depressurization of the space, fresh air dampers may be required as part of the building's ventilation system.

Economizers

As promulgated by ASHRAE, economizers reduce operating expenses and compressor run time by providing a source of free cooling and a means of ventilation to match changing application needs. When properly designed (per ASHRAE standards), the economizer will control the amount of outdoor air allowed into the building and is integrated with the operation of the compressors. Carrier economizers are properly designed and allow free cooling to occur when the outdoor air is suitable depending upon the control strategy chosen.

It has also been proven (by multiple independent sources) that using a Demand Controlled Ventilation (CO₂) strategy will result in considerable energy savings over a constant outdoor air volume strategy. This is because air to be brought in at a fixed rate has no variability as the outside air conditions change. Modulating EnergyX systems with DCV control allows the outside ventilation air to be reduced to the minimum building ventilation requirements as required by the actual occupancy load, which in turn reduces the load on the unit compressors or heating system.

It is recommended that an economizer option always be used with the EnergyX system. This allows for true free cooling operation when the outside air conditions allow for it.

Wheel Cleaning

The EnergyX system includes a 5 year wheel warranty as a standard product feature. Wheels are self cleaning from dry dust and dirt due to laminar airflow through the wheel. If volatile organic compounds (VOCs) are present, wheels need to be 'deep' cleaned just like evaporator coils must be in order to maintain latent recovery performance. Since it is easier and less risky to clean a wheel outside of the HVAC unit than within, EnergyX unit construction allows for easy wheel segment removal.

It is recommended that a different wheel segment be cleaned each time the unit air filters are changed in order to ensure periodic entire wheel cleaning. Wheel cleaning can be done simply and easily by hand. Proper wheel cleaning does not remove wheel desiccant. See the EnergyX Controls & Troubleshooting Supplement Instructions for additional wheel cleaning and service information.

Exhaust Fan Performance

Many applications that utilize energy recovery incorporate ducted return/exhaust air paths. In these applications, it is important to consider the duct pressure of the return/

Application data (cont)



exhaust just as a designer would consider the effects of the supply duct static pressure on the airflow of the rooftop unit itself.

EnergyX Modulating Volume 15 to 25 ton Units

The exhaust fan in the Modulating Volume EnergyX unit will assist the rooftop unit fan in pulling air through the exhaust/return duct. These exhaust fans are backwards curved impeller designs which are capable of significant more static pressure operation than typical forward curved fan designs. The exhaust fan performance curves on page 55 are provided for additional guidance when considering return/exhaust duct design.

NOTE: If application designs require two separate ducts (one for exhaust air, one for return air) contact your Carrier Sales Engineer for additional guidance prior to specification or ordering.

Application/Selection Option

Selection software by Carrier saves time by performing many of the steps above. Contact your Carrier sales representative for assistance.

Note about this specification: These specifications are written in “Masterformat” as published by the Construction Specification Institute. Please feel free to copy this specification directly into your building spec.

WeatherMaster® Cooling Only/Electric Heat Packaged Rooftop

HVAC guide specifications

Size range: **15 to 25 Nominal Tons**

Carrier Model Number: **50HC*17-28**

Part 1 — (23 06 80) Schedules for decentralized HVAC equipment

- 1.01 (23 06 80.13) Decentralized Unitary HVAC Equipment Schedule
- A. (23 06 80.13.A.) Rooftop unit (RTU) schedule
1. Schedule is per the project specification requirements.

Part 2 — (23 07 16) HVAC equipment insulation

- 2.01 (23 07 16.13) Decentralized, Rooftop Units:
- A. (23 07 16.13.A.) Evaporator fan compartment:
1. Interior cabinet surfaces shall be insulated with a minimum 1/2-in. thick, minimum 1 1/2-lb density, flexible fiberglass insulation bonded with a phenolic binder, neoprene coated on the air side.
 2. Insulation and adhesive shall meet NFPA 90A requirements for flame spread and smoke generation.
 3. Unit internal insulation linings shall be resistant to mold growth in accordance with “mold growth and humidity” test in ASTM C1338, G21, and UL 181 or comparable test method. Air stream surfaces shall be evaluated in accordance with the “Erosion Test” in UL 181, as part of ASTM C1071.
- B. (23 07 16.13.B.) Electric heat compartment:
1. Aluminum foil-faced fiberglass insulation shall be used.
 2. Insulation and adhesive shall meet NFPA 90A requirements for flame spread and smoke generation.

Part 3 — (23 09 13) Instrumentation and control devices for HVAC

- 3.01 (23 09 13.23) Sensors and Transmitters
- A. (23 09 13.23.A.) Thermostats
1. Thermostat must
 - a. energize both “W” and “G” when calling for heat.
 - b. have capability to energize 2 different stages of cooling, and 2 different stages of heating.
 - c. include capability for occupancy scheduling.

Part 4 — (23 09 23) Direct-digital control system for HVAC

- 4.01 (23 09 23.13) Decentralized, Rooftop Units:
- A. (23 09 23.13.A.) PremierLink™ controller
1. Shall be ASHRAE 62 compliant.
 2. Shall accept 18-32 VAC input power.
 3. Shall have an operating temperature range from -40°F (-40°C) to 158°F (70°C), 10% to 95% RH (non-condensing).
 4. Shall include an integrated economizer controller to support an economizer with 4 to 20 mA actuator input and no microprocessor controller.
 5. Controller shall accept the following inputs: space temperature, setpoint adjustment, outdoor air temperature, indoor air quality, outdoor air quality, indoor relative humidity, compressor lock-out, fire shutdown, enthalpy, fan status, remote time clock/door switch.
 6. Shall accept a CO₂ sensor in the conditioned space, and be Demand Controlled Ventilation (DCV) ready.
 7. Shall provide the following outputs: economizer, fan, cooling stage 1, cooling stage 2, heat stage 1, heat stage 2, heat stage 3/exhaust/reversing valve/dehumidify/occupied.
 8. Unit shall provide surge protection for the controller through a circuit breaker.
 9. Shall be Internet capable, and communicate at a Baud rate of 38.4K or faster.
 10. Shall have an LED display independently showing the status of activity on the communication bus, and processor operation.
 11. Shall include an EIA-485 protocol communication port, an access port for connection of either a computer or a Carrier technician tool, an EIA-485 port for network communication to intelligent space sensors and displays, and a port to connect an optional LonWorks¹ plug-in communications card.
 12. Shall have built-in Carrier Comfort Network® (CCN) protocol, and be compatible with other CCN devices, including ComfortLink and ComfortVIEW™ controllers.
 13. Shall have built-in support for Carrier technician tool.
 14. Software upgrades will be accomplished by local download. Software upgrades through chip replacements are not allowed.
 15. Shall be shock resistant in all planes to 5G peak, 11ms during operation, and 100G peak, 11ms during storage.
 16. Shall be vibration resistant in all planes to 1.5G at 20-300 Hz.

1. LonWorks is a registered trademark of Echelon Corporation.

17. Shall support a bus length of 4000 ft (1219 m) max, 60 devices per 1000 ft (305 m) section, and 1 RS-485 repeater per 1000 ft (305 m) sections.
- B. (23 09 23.13.B.) RTU Open protocol, direct digital controller:
 1. Shall be ASHRAE 62 compliant.
 2. Shall accept 18-30VAC, 50-60Hz, and consume 15VA or less power.
 3. Shall have an operating temperature range from -40°F (-40°C) to 130°F (54°C), 10% to 90% RH (non-condensing).
 4. Shall include built-in protocol for BACnet¹ (MS/TP and PTP modes), Modbus² (RTU and ASCII), Johnson N2 and LonWorks. LonWorks Echelon processor required for all Lon applications shall be contained in separate communication board.
 5. Shall allow access of up to 62 network variables (SNVT). Shall be compatible with all open controllers.
 6. Baud rate Controller shall be selectable using a dip switch.
 7. Shall have an LED display independently showing the status of serial communication, running, errors, power, all digital outputs, and all analog inputs.
 8. Shall accept the following inputs: space temperature, setpoint adjustment, outdoor air temperature, indoor air quality, outdoor air quality, compressor lock-out, fire shutdown, enthalpy switch, and fan status / filter status / humidity / remote occupancy.
 9. Shall provide the following outputs: economizer, variable frequency drive, fan, cooling stage 1, cooling stage 2, heat stage 1, heat stage 2, exhaust reversing valve/high fan speed.
 10. Shall have built-in surge protection circuitry through solid-state polyswitches. Polyswitches shall be used on incoming power and network connections. Polyswitches will return to normal when the "trip" condition clears.
 11. Shall have a battery backup capable of a minimum of 10,000 hours of data and time clock retention during power outages.
 12. Shall have built-in support for Carrier technician tool.
 13. Shall include an RS-485 protocol communication port, an access port for connection of either a computer or a Carrier technician tool, an RS-485 port for network communication

1. BACnet is a registered trademark of ASHRAE (American Society of Heating, Refrigerating and Air-Conditioning Engineers).
2. Modbus is a registered trademark of Schneider Electric.

to intelligent space sensors and displays, and a port to connect an optional LonWorks communications card.

14. Software upgrades will be accomplished by either local or remote download. No software upgrades through chip replacements are allowed.
- C. (23 09 23.13.C.) *ComfortLink* Unit Controls shall contain:
 1. Four button detailed English scrolling marquee display.
 2. CCN (Carrier Comfort Network) capable.
 3. Unit control with standard suction pressure transducers and condensing temperature thermistors.
 4. Shall provide a 5°F temperature difference between cooling and heating set points to meet ASHRAE 90.1-2016 Energy Standard.
 5. Shall provide and display a current alarm list and an alarm history list.
 6. Service run test capability.
 7. Shall accept input from a CO₂ sensor (both indoor and outdoor).
 8. Configurable alarm light shall be provided which activates when certain types of alarms occur.
 9. Compressor minimum run time (3 minutes) and minimum off time (5 minutes) are provided.
 10. Service diagnostic mode.
 11. Economizer control (optional).
 12. Control multiple capacity stages.
 13. Unit shall be complete with self-contained low voltage control circuit.
 14. Unit shall have 0°F low ambient cooling operation.

Part 5 — (23 09 33) Electric and electronic control system for HVAC

5.01 (23 09 33.13) Decentralized, rooftop units

- A. (23 09 33.13.A) General:
 1. Shall be complete with self-contained low-voltage control circuit protected by a resettable circuit breaker on the 24-v transformer side. Transformer shall have 75VA capability.
 2. Shall utilize color-coded wiring.
 3. Shall include a central control terminal board to conveniently and safely provide connection points for vital control functions such as: smoke detectors, phase monitor, economizer, thermostat, DDC control options, and low and high pressure switches.
 4. Unit shall include a minimum of one 8-pin screw terminal connection board for connection of control wiring.

B. (23 09 33.13.B) Safeties:

1. Compressor over-temperature, over-current.
2. Low-pressure switch:
 - a. Units shall have different sized connectors for the circuit 1 and circuit 2 low and high pressure switches. They shall physically prevent the cross-wiring of the safety switches between circuits 1 and 2.
 - b. Low pressure switch shall use different color wire than the high pressure switch. The purpose is to assist the installer and service technician to correctly wire and or troubleshoot the rooftop unit.
3. High-pressure switch.
 - a. Units with 2 compressors shall have different sized connectors for the circuit 1 and circuit 2 low and high pressure switches. They shall physically prevent the cross-wiring of the safety switches between circuits 1 and 2.
 - b. Low pressure switch shall use different color wire than the high-pressure switch. The purpose is to assist the installer and service technician to correctly wire and/or troubleshoot the rooftop unit.
4. Automatic reset, motor thermal overload protector.

Part 6 — (23 09 93) Sequence of operations for HVAC controls

6.01 (23 09 93.13) Decentralized, Rooftop Units:

- A. (23 09 93.13.A) INSERT SEQUENCE OF OPERATION

Part 7 — (23 40 13) Panel air filters

7.01 (23 40 13 13) Decentralized rooftop units:

- A. (23 40 13 13.A) Standard filter section
1. Shall consist of factory-installed, low velocity, throwaway 2-in. thick fiberglass filters of commercially available sizes.
 2. Unit shall use only one filter size. Multiple sizes are not acceptable.
 3. Filters shall be accessible through an access panel with “no-tool” removal as described in the unit cabinet section of this specification (23 81 19.13.G).

Part 8 — (23 81 19) Self-contained air conditioners

8.01 (23 81 19.13) Medium-Capacity Self-Contained Air Conditioners (50HC*D17-28)

- A. (23 81 19.13.A) General:
1. Outdoor, rooftop mounted, electrically controlled, heating and cooling unit utilizing hermetic scroll compressor(s) for cooling duty and gas combustion for heating duty.
 2. Factory assembled, single piece heating and cooling rooftop unit. Contained within the unit enclosure shall be all factory wiring, piping,

controls, and special features required prior to field start-up.

3. Unit shall use Puron® R-410A refrigerant.
4. Unit shall be installed in accordance with the manufacturer’s instructions.
5. Unit must be selected and installed in compliance with local, state, and federal codes.

B. (23 81 19.13.B.) Quality Assurance:

1. Unit meets ASHRAE 90.1-2016 and IECC¹-2015 minimum efficiency requirements.
2. Units are Energy Star certified where sizes are required.
3. Unit shall be rated in accordance with AHRI Standard 340/360.
4. Unit shall be designed to conform to ASHRAE 15.
5. Unit shall be ETL-tested and certified in accordance with ANSI Z21.47 Standards and ETL-listed and certified under Canadian standards as a total package for safety requirements.
6. Insulation and adhesive shall meet NFPA 90A requirements for flame spread and smoke generation.
7. Unit internal insulation linings shall be resistant to mold growth in accordance with “mold growth and humidity” test in ASTM C1338, G21, and UL 181 or comparable test method. Air stream surfaces shall be evaluated in accordance with the “Erosion Test” in UL 181, as part of ASTM C1071.
8. Unit casing shall be capable of withstanding 500 hour salt spray exposure per ASTM B117 (scribed specimen).
9. Roof curb shall be designed to conform to NRCA Standards.
10. Unit shall be subjected to a completely automated run test on the assembly line. The data for each unit will be stored at the factory, and must be available upon request.
11. Unit shall be designed in accordance with UL Standard 1995, including tested to withstand rain.
12. Unit shall be constructed to prevent intrusion of snow and tested to prevent snow intrusion into the control box up to 40 mph.
13. Unit shake tested to assurance level 1, ASTM D4169 to ensure shipping reliability.
14. High-Efficiency Motors listed shall meet section 313 of the Energy Independence and Security Act of 2007 (EISA 2007).

C. (23 81 19.13.C) Delivery, storage, and handling:

1. Unit shall be stored and handled per manufacturer’s recommendations.

1. IECC is a registered trademark of the International Code Council, Inc.

2. Lifted by crane requires either shipping top panel or spreader bars.
3. Unit shall only be stored or positioned in the upright position.
- D. (23 81 19.13.D) Project conditions:
 1. As specified in the contract.
- E. (23 81 19.13.E) Operating characteristics:
 1. Unit shall be capable of starting and running at 125°F (52°C) ambient outdoor temperature, meeting maximum load criteria of AHRI Standard 340/360 at ± 10% voltage.
 2. Compressor with standard controls shall be capable of operation from 35°F (2°C), ambient outdoor temperatures. Accessory kits are necessary if mechanically cooling at ambient temperatures below 35°F (2°C).
 3. Unit shall discharge supply air vertically or horizontally as shown on contract drawings.
 4. Unit shall be factory configured and ordered for vertical supply and return configurations.
 5. Unit shall be factory furnished for either vertical or horizontal configuration without the use of special conversion kits.
 6. No field kits conversion is possible.
- F. (23 81 19.13.F) Electrical Requirements:
 1. Main power supply voltage, phase, and frequency must match those required by the manufacturer.
- G. (23 81 19.13.G) Unit Cabinet:
 1. Unit cabinet shall be constructed of galvanized steel, and shall be bonderized and coated with a pre-painted baked enamel finish on all externally exposed surfaces.
 2. Unit cabinet exterior paint shall be: film thickness, (dry) 0.003 inches minimum, gloss (per ASTM D523, 60°F): 60, Hardness: H-2H Pencil hardness.
 3. Evaporator fan compartment interior cabinet insulation shall conform to AHRI Standards 340/360 minimum exterior sweat criteria. Interior surfaces shall be insulated with a minimum 1/2-in. thick, 1 lb density, flexible fiberglass insulation, neoprene coated on the air side. Aluminum foil-faced fiberglass insulation shall be used in the heat compartment.
 4. Unit internal insulation linings shall be resistant to mold growth in accordance with “mold growth and humidity” test in ASTM C1338, G21, and UL 181 or comparable test method. Air stream surfaces shall be evaluated in accordance with the “Erosion Test” in UL 181, as part of ASTM C1071.
 5. Base of unit shall have a minimum of four locations for factory thru-the-base electrical connections. Connections shall be internal to the cabinet to protect from environmental issues.
6. Base Rail:
 - a. Unit shall have base rails on a minimum of 2 sides.
 - b. Holes shall be provided in the base rails for rigging shackles to facilitate maneuvering and overhead rigging.
 - c. Holes shall be provided in the base rail for moving the rooftop by fork truck.
 - d. Base rail shall be a minimum of 16 gage thickness.
7. Condensate pan and connections:
 - a. Shall be a sloped condensate drain pan made of a non-corrosive material.
 - b. Shall comply with ASHRAE Standard 62.
 - c. Shall use a 3/4-in. 14 NPT drain connection at the end of the drain pan. Connection shall be made per manufacturer’s recommendations.
8. Top panel:
 - a. Shall be a multi-piece top panel linked with water tight flanges and interlocking systems.
9. Electrical Connections:
 - a. All unit power wiring shall enter unit cabinet at a single, factory-prepared, knockout location.
 - b. Thru-the-base capability:
 - 1) Thru-the-base provisions / connections are available as standard with every unit. When bottom connections are required, field furnished couplings are required.
 - 2) No basepan penetration, other than those authorized by the manufacturer, is permitted.
10. Component access panels (standard):
 - a. Cabinet panels shall be easily removable for servicing.
 - b. Unit shall have one factory installed, tool-less, removable, filter access panel.
 - c. Panels covering control box and filters shall have molded composite handles while the blower access door shall have an integrated flange for easy removal.
 - d. Handles shall be UV modified, composite, permanently attached, and recessed into the panel.
 - e. Screws on the vertical portion of all removable access panel shall engage into heat resistant, molded composite collars.
 - f. Collars shall be removable and easily replaceable using manufacturer recommended parts.
- H. (23 81 19.13.H.) Coils:
 1. Standard Aluminum Fin/Copper Tube Coils:
 - a. Standard evaporator and condenser coils shall have aluminum lanced plate fins mechanically bonded to seamless internally grooved copper tubes with all joints brazed.

- b. Evaporator coils shall be leak tested to 150 psig, pressure tested to 450 psig, and qualified to UL 1995 burst test at 1775 psig.
 - c. Condenser coils shall be leak tested to 150 psig, pressure tested to 650 psig, and qualified to UL 1995 burst test at 1980 psig.
2. Optional Pre-coated aluminum-fin condenser coils:
 - a. Shall have a durable epoxy-phenolic coating to provide protection in mildly corrosive coastal environments.
 - b. Coating shall be applied to the aluminum fin stock prior to the fin stamping process to create an inert barrier between the aluminum fin and copper tube.
 - c. Epoxy-phenolic barrier shall minimize galvanic action between dissimilar metals.
 - d. Corrosion durability of fin stock shall be confirmed through testing to be no less than 1000 hours salt spray per ASTM B117-90.
 - e. Corrosion durability of fin stock shall be confirmed through testing to have no visible corrosion after 48 hour immersion in a room temperature solution of 5% salt, 1% acetic acid.
 - f. Fin stock coating shall pass 2000 hours of the following: one week exposure in the prohesion chamber followed by one week of accelerated ultraviolet light testing. Prohesion chamber: the solution shall contain 3.5% sodium chloride and 0.35% ammonium sulfate. The exposure cycle is one hour of salt fog application at ambient followed by one hour drying at 95°F (35°C).
 3. Optional Copper-fin evaporator and condenser coils:
 - a. Shall be constructed of copper fins mechanically bonded to copper tubes and copper tube sheets.
 - b. Galvanized steel tube sheets shall not be acceptable.
 - c. A polymer strip shall prevent coil assembly from contacting the sheet metal coil pan to minimize potential for galvanic corrosion between coil and pan.
 4. Optional E-coated aluminum-fin evaporator and condenser coils:
 - a. Shall have a flexible epoxy polymer coating uniformly applied to all coil surface areas without material bridging between fins.
 - b. Coating process shall ensure complete coil encapsulation of tubes, fins and headers.
 - c. Color shall be high gloss black with gloss per ASTM D523-89.
 - d. Uniform dry film thickness from 0.8 to 1.2 mil on all surface areas including fin edges.
 - e. Superior hardness characteristics of 2H per ASTM D3363-92A and cross-hatch adhesion of 4B-5B per ASTM D3359-93.
 - f. Impact resistance shall be up to 160 in.-lb (ASTM D2794-93).
 - g. Humidity and water immersion resistance shall be up to minimum 1000 and 250 hours respectively (ASTM D224-92 and ASTM D870-92).
 - h. Corrosion durability shall be confirmed through testing to be no less than 6000 hours salt spray per ASTM B117-90.
5. Optional E-coated aluminum-fin, aluminum tube condenser coils:
 - a. Shall have a flexible epoxy polymer coating uniformly applied to all coil external surface areas without material bridging between fins or louvers.
 - b. Coating process shall ensure complete coil encapsulation, including all exposed fin edges.
 - c. E-coat thickness of 0.8 to 1.2 mil with top coat having a uniform dry film thickness from 1.0 to 2.0 mil on all external coil surface areas, including fin edges, shall be provided.
 - d. Shall have superior hardness characteristics of 2H per ASTM D3363-00 and cross-hatch adhesion of 4B-5B per ASTM D3359-02.
 - e. Shall have superior impact resistance with no cracking, chipping or peeling per NSF/ANSI 51-2002 Method 10.2.
- I. (23 81 19.13.I) Refrigerant components:
 1. Refrigerant circuit shall include the following control, safety, and maintenance features:
 - a. Thermostatic Expansion Valve (TXV) shall help provide optimum performance across the entire operating range. Shall contain removable power element to allow change out of power element and bulb without removing the valve body.
 - b. Refrigerant filter drier.
 - c. Service gage connections on suction and discharge lines.
 - d. Pressure gage access through a specially designed access port in the top panel of the unit.
 2. There shall be gage line access port in the skin of the rooftop, covered by a black, removable plug:
 - a. The plug shall be easy to remove and replace.
 - b. When the plug is removed, the gage access port shall enable maintenance personnel to route their pressure gage lines.

- c. This gage access port shall facilitate correct and accurate condenser pressure readings by enabling the reading with the compressor access panel on.
 - d. The plug shall be made of a leak proof, UV-resistant, composite material.
3. Compressors:
- a. Unit shall use one fully hermetic, scroll compressor for each independent refrigeration circuit.
 - b. Models shall be available with 2 compressor/2-stage cooling.
 - c. Compressor motors shall be cooled by refrigerant gas passing through motor windings.
 - d. Compressors shall be internally protected from high discharge temperature conditions.
 - e. Compressors shall be protected from an over-temperature and over-amperage conditions by an internal, motor overload device.
 - f. Compressor shall be factory mounted on rubber grommets.
 - g. Compressor motors shall have internal line break thermal, current overload and high pressure differential protection.
 - h. Crankcase heaters shall be utilized on all models to protect compressor with specific refrigerant charge.
- J. (23 81 19.13.J) Filter section:
- 1. Filters access is specified in the unit cabinet section of this specification.
 - 2. Filters shall be held in place by a preformed slide out filter tray, facilitating easy removal and installation.
 - 3. Shall consist of factory-installed, low velocity, throw-away 2-in. thick fiberglass filters.
 - 4. Filters shall be standard, commercially available sizes.
 - 5. Only one size filter per unit is allowed.
 - 6. 4-in. filter capability is possible with a field-installed pre-engineered slide out filter track accessory. 4-in. filters are field furnished.
- K. (23 81 19.13.K) Evaporator fan and motor:
- 1. Evaporator fan motor:
 - a. Shall have permanently lubricated bearings.
 - b. Shall have inherent automatic-reset thermal overload protection or circuit breaker.
 - c. Shall have a maximum continuous bhp rating for continuous duty operation; no safety factors above that rating shall be required.
 - 2. Belt-driven evaporator fan:
 - a. Belt drive shall include an adjustable-pitch motor pulley and belt break protection system.
 - b. Shall use rigid pillow block bearing system with lubricate fittings at are accessible or lubrication line.
 - c. Blower fan shall be double-inlet type with forward-curved blades.
 - d. Shall be constructed from steel with a corrosion resistant finish and dynamically balanced.
 - e. Standard on all 17-28 size models with Humidi-MiZer system.
- L. (23 81 19.13.L) Condenser Fans and Motors:
- 1. Condenser fan motors:
 - a. Shall be a totally enclosed motor.
 - b. Shall use permanently lubricated bearings.
 - c. Shall have inherent thermal overload protection with an automatic reset feature.
 - d. Shall use a shaft down design on all sizes.
 - 2. Condenser fans:
 - a. Shall be a direct driven propeller type fan.
 - b. Shall have aluminum blades riveted to corrosion resistant steel spiders and shall be dynamically balanced.
- M. (23 81 19.13.M.) Special features, options, and accessories:
- 1. EnergyX[®] and Economizer:
 - a. System Description:
 - 1) One-piece EnergyX (Energy Recovery Ventilation) unit is an electrically controlled ventilation air pre-conditioner utilizing an AHRI 1060 certified Energy Recovery Cassette to reduce the cooling and heating loads placed on the primary HVAC unit by untreated outdoor air. Building exhaust air shall be introduced to the EnergyX unit through ductwork. Unit shall be designed as a factory-installed option to be used with WeatherMaster 50HC units for use in vertical return applications only.
 - b. Quality Assurance:
 - 1) Unit shall be designed in accordance with UL Standard 1995.
 - 2) Energy Recovery unit shall be ETL tested and certified.
 - 3) Rooftop unit and Energy Recovery unit shall be ETL certified as one single system.
 - 4) Roof curb or curb extension shall be designed to conform to NRCA Standards.
 - 5) Insulation and adhesive shall meet NFPA 90A requirements for flame spread and smoke generation.
 - 6) Unit casing shall be capable of withstanding ASTM No. 141 (Method 6061) 500-hour salt spray test.
 - 7) Unit shall contain AHRI 1060 certified Energy Recovery Cassette.
 - 8) Unit shall leakage rates shall be capable of meeting ASHRAE Standard 62.1

- requirements for use of class-2 exhaust with class-1 ventilation air.
- c. Products:
- 1) Equipment (Standard): The EnergyX unit shall be a factory assembled, single piece unit. Contained within the unit enclosure shall be all factory wiring with a single, pre-determined point of power input and a single point of 24-volt control wiring.
 - 2) Unit Cabinet:
 - a) Unit cabinet shall be constructed of galvanized steel coated with a pre-painted baked enamel finish.
 - b) All models shall have hoods installed over outside air intake and exhaust openings. Outside air hood shall have aluminum water entrainment filters.
 - c) All models have 1-in., 2 pound density fiberglass insulation.
 - d) Hinged access doors with compression latches shall be provided on all units for access to fans and filters. Hinged doors shall be provided with at least one handle capable of being locked.
 - e) Exhaust air stream shall have back-draft dampers to prevent air penetration during off cycles.
 - f) Holes shall be provided in the base rails for rigging shackles to facilitate overhead rigging.
 - 3) Blowers:
 - a) Blowers shall be direct drive with variable speed motors.
 - b) Blower wheel shall be made of steel with a corrosion resistant finish. It shall be dynamically balanced, double-inlet type with backward-curved blades.
 - c) Blower shall be mounted on neoprene vibration isolation pads.
 - d) Motor shall be high efficiency and have thermal overload protection.
 - 4) Filter Section:
 - a) Standard filter section shall accept commercially available, 2-in. pleated filter(s).
 - 5) Controls and Safeties:
 - a) The EnergyX unit shall operate in conjunction with rooftop unit fan.
 - 6) Electrical Requirements:
 - a) All unit power wiring shall enter unit cabinet at a single location.
 - 7) Energy Recovery Cassette:
 - a) The energy recovery media shall have a minimum of 70% effectiveness at nominal unit airflow.
 - b) Energy wheel performance shall be AHRI Standard 1060 Certified and bear the AHRI Certified Product Seal.
 - c) The energy recovery cassette shall be an UL Recognized component for electrical and fire safety.
 - d) The wheel shall be coated with silica gel desiccant, permanently bonded without the use of binders or adhesives.
 - e) Coated wheels shall be washable with detergent or alkaline coil cleaner and water.
 - f) The silica gel shall not dissolve or deliquesce in the presence of water or high humidity.
 - g) The substrate shall be made of a lightweight polymer and shall not degrade or require additional coatings for application in coastal environments.
 - h) The wheel polymer layers shall be wound continuously with one flat and one structured layer in an ideal parallel plate geometry providing laminar flow and minimum pressure drop.
 - i) The polymer layers shall be captured in a stainless steel wheel frame or aluminum and stainless steel segment frames that provide a rigid and self-supporting matrix.
 - j) Energy recovery wheels greater than 19-in. in diameter shall be provided with removable wheel segments.
 - k) Wheel frame shall be a welded hub, spoke and rim assembly of stainless, plated, and or coated steel and shall be self supporting without the wheel segments in place.
 - l) Wheel segments shall be removable without the use of tools to facilitate maintenance and cleaning.
 - m) Wheel rim shall be continuous rolled stainless steel and the wheel shall be connected to the shaft by means of taper locks.
 - n) Wheel bearings shall provide an L-10 life of 400,000 hours.
 - o) Drive belts of stretch urethane shall be provided for wheel rim drive without the need for external tensioners or adjustment.
- 8) Supply and exhaust air frost control option:
- a) Factory-installed frost protection module shall sense pressure differential across the energy recovery cassette.
 - b) Supply blower shall be shut-off if the pressure differential across the energy recovery cassette exceeds an adjustable set point. Blower shall remain off for an adjustable time period.
 - c) Exhaust blower and wheel shall remain in operation in order to

- remove any frost build-up on the wheel.
- 9) EnergyX maintenance indicator package:
 - a) A factory-installed switch shall monitor EnergyX blowers and wheel motor amp draw and send a signal to field-supplied 24-v indicator upon amperage surge that maintenance required.
 - 10) Filter maintenance indicator:
 - a) A factory-installed differential pressure switch shall measure pressure drop across the outside air filter and activate a field-supplied 24-v indicator when airflow is restricted. It shall not interrupt EnergyX operation. Switch set point shall be adjustable.
 - 11) EnergyX free cooling with enthalpy and stop/jog control:
 - a) An enthalpy sensor shall prevent the wheel from rotating if the outside air conditions are acceptable for free cooling. Both exhaust and supply blowers will remain on.
 - b) Stop-Jog-Control shall energize the wheel periodically during the free cooling operation of the EnergyX to prevent dirt build-up on the wheel.
 - 12) Economizer Option:
 - a) The economizer shall be integrated in the energy recovery module and shall allow air to bypass the energy recovery wheel for free cooling and fail safe operation. Tilting wheel mechanisms shall not be allowed.
 - b) The economizer damper shall be motorized with factory installed, 24-v Belimo actuator.
 - c) The EnergyX shall be capable of using the economizer in a free cooling operation. The economizer shall utilize enthalpy sensor controls when in the economizer mode.
2. Staged Air Volume System (SAV™) for 2-stage cooling models only:
 - a. Evaporator fan motor:
 - 1) Shall have permanently lubricated bearings.
 - 2) Shall have a maximum continuous bhp rating for continuous duty operation; no safety factors above that rating.
 - 3) Shall be Variable Frequency duty and 2-speed control.
 - 4) Shall contain motor shaft grounding ring to prevent electrical bearing fluting damage by safely diverting harmful shaft voltages and bearing currents to ground.
 3. Variable frequency drive (VFD). Only available on 2-speed indoor fan motor option (SAV):
 - a. Factory-supplied VFDs qualify, through ABB for a 24-month warranty from date of commissioning or 30 months from date of sale, whichever occurs first.
 - b. Shall be installed inside the unit cabinet, mounted, wired and tested.
 - c. Shall contain Electromagnetic Interference (EMI) frequency protection.
 - d. Insulated Gate Bi-Polar Transistors (IGBT) used to produce the output pulse width modulated (PWM) waveform, allowing for quiet motor operation.
 - e. Self diagnostics with fault and power code LED indicator. Field accessory Display Kit available for further diagnostics and special setup applications.
 - f. RS485 capability standard.
 - g. Electronic thermal overload protection.
 - h. 5% swinging chokes for harmonic reduction and improved power factor.
 - i. All printed circuit boards shall be conformal coated.
 4. Integrated EconoMi\$er® IV, EconoMi\$er 2, and EconoMi\$er X low leak rate models. (Factory-installed on 3-phase models only. Field installed on all 3 and 1-phase models):
 - a. Integrated, gear driven opposing modulating blade design type capable of simultaneous economizer and compressor operation.
 - b. Independent modules for vertical or horizontal return configuration shall be available. Vertical return modules shall be available as a factory-installed option.
 - c. Damper blades shall be galvanized steel with composite gears. Plastic or composite blades on intake or return shall not be acceptable.
 - d. Shall include all hardware and controls to provide free cooling with outdoor air when temperature and/or humidity are below setpoints.
 - e. Shall be equipped with gear driven dampers for both the outdoor ventilation air and the return air for positive air stream control.
 - f. Low leak rate models shall be equipped with dampers not to exceed 2% leakage at 1 in. wg pressure differential.
 - g. Economizer controller on EconoMi\$er IV models shall be Honeywell W7212 that provides:
 - 1) Combined minimum and DCV maximum damper position potentiometers with compressor staging relay.
 - 2) Functions with solid state analog enthalpy or dry bulb changeover control sensing.

- 3) LED indicators for: when free cooling is available, when module is in DCV mode, when exhaust fan contact is closed.
- h. Economizer controller on EconoMi\$er X models shall be the Honeywell W7220 that provides:
 - 1) 2-line LCD interface screen for setup, configuration and troubleshooting.
 - 2) On-board Fault Detection and Diagnostics (FDD) that senses and alerts when the economizer is not operating properly, per California Title 24.
 - 3) Sensor failure loss of communication identification.
 - 4) Automatic sensor detection.
 - 5) Capabilities for use with multiple-speed indoor fan systems.
 - 6) Utilize digital sensors: Dry bulb and Enthalpy.
- i. Economizer controller on EconoMi\$er 2 models with PremierLink™ controller shall be 4 to 20mA design and controlled by the PremierLink controller. PremierLink does not comply with California Title 24 Fault Detection and Diagnostic (FDD) requirements.
- j. Economizer controller on EconoMi\$er 2 models with RTU Open controller shall be a 4 to 20mA design controlled directly by the RTU Open controller. RTU Open controller meets California Title 24 Fault Detection and Diagnostic (FDD) requirements.
- k. Shall be capable of introducing up to 100% outdoor air.
- l. Shall be equipped with a barometric relief damper capable of relieving up to 100% return air and contain seals that meet ASHRAE 90.1-2016 and IECC-2015 requirements.
- m. Shall be designed to close damper(s) during loss-of-power situations with spring return built into motor.
- n. Dry bulb outdoor air temperature sensor shall be provided as standard. Enthalpy sensor is also available on factory-installed only. Outdoor air sensor setpoint shall be adjustable and shall range from 40°F to 100°F (4°C to 38°C). Additional sensor options shall be available as accessories.
- o. The economizer controller shall also provide control of an accessory power exhaust unit function. Factory set at 100%, with a range of 0% to 100%.
- p. The economizer shall maintain minimum air-flow into the building during occupied period and provide design ventilation rate for full occupancy.
- q. Dampers shall be completely closed when the unit is in the unoccupied mode.
- r. Economizer controller shall accept a 2 to 10 Vdc CO₂ sensor input for IAQ/DCV control. In this mode, dampers shall modulate the outdoor air damper to provide ventilation based on the sensor input.
- s. Compressor lockout temperature on W7220 is adjustable from -45°F to 80°F, set at a factory default of 32°F. Others shall open at 35°F (2°C) and close at 50°F (10°C).
- t. Actuator shall be direct coupled to economizer gear. No linkage arms or control rods shall be acceptable.
- u. Economizer controller shall provide indications when in free cooling mode, in the DCV mode, or the exhaust fan contact is closed.
5. Integrated EconoMi\$er2, and EconoMi\$er X Ultra Low Leak rate models. (Factory-installed on 3 phase models only. Field-installed on all 3 and 1 phase models):
 - a. Integrated, gear driven opposing modulating blade design type capable of simultaneous economizer and compressor operation.
 - b. Independent modules for vertical or horizontal return configuration shall be available. Vertical return modules shall be available as a factory-installed option.
 - c. Damper blades shall be galvanized steel with composite gears. Plastic or composite blades on intake or return shall not be acceptable.
 - d. Shall include all hardware and controls to provide free cooling with outdoor air when temperature and/or humidity are below setpoints.
 - e. Shall be equipped with gear driven dampers for both the outdoor ventilation air and the return air for positive air stream control.
 - f. Ultra Low Leak design meets California Title 24 section 140.4 and, ASHRAE 90.1-2016 and IECC-2015 requirements for 4 cfm per sq. ft. on the outside air dampers and 10 cfm per sq. ft. on the return dampers.
 - g. Economizer controller on EconoMi\$er X models shall be the Honeywell W7220 that provides:
 - 1) 2-line LCD interface screen for setup, configuration and troubleshooting
 - 2) On-board Fault Detection and Diagnostics (FDD) that senses and alerts when the economizer is not operating properly, per California Title 24.
 - 3) Sensor failure loss of communication identification.
 - 4) Automatic sensor detection.
 - 5) Capabilities for use with multiple-speed indoor fan systems.
 - 6) Utilize digital sensors: Dry bulb and Enthalpy.

- h. Economizer controller on EconoMiSer 2 models with RTU Open controller shall be a 4 to 20mA design controlled directly by the RTU Open controller. RTU Open controller meets California Title 24 Fault Detection and Diagnostic (FDD) requirements.
 - i. Shall be capable of introducing up to 100% outdoor air.
 - j. Shall be equipped with a barometric relief damper capable of relieving up to 100% return air and contain seals that meet ASHRAE 90.1-2016 and IECC-2015 requirements.
 - k. Shall be designed to close damper(s) during loss-of-power situations with spring return built into motor.
 - l. Dry bulb outdoor air temperature sensor shall be provided as standard. Enthalpy sensor is also available on factory-installed only. Outdoor air sensor setpoint shall be adjustable and shall range from 40°F to 100°F (4°C to 38°C). Additional sensor options shall be available as accessories.
 - m. The economizer controller shall also provide control of an accessory power exhaust unit function. Factory set at 100%, with a range of 0% to 100%.
 - n. The economizer shall maintain minimum airflow into the building during occupied period and provide design ventilation rate for full occupancy.
 - o. Dampers shall be completely closed when the unit is in the unoccupied mode.
 - p. Economizer controller shall accept a 2 to 10 Vdc CO₂ sensor input for IAQ/DCV control. In this mode, dampers shall modulate the outdoor air damper to provide ventilation based on the sensor input.
 - q. Compressor lockout temperature on W7220 is adjustable from -45°F to 80°F, set at a factory default of 32°F (0°C). Others shall open at 35°F (2°C) and closes at 50°F (10°C).
 - r. Actuator shall be direct coupled to economizer gear. No linkage arms or control rods shall be acceptable.
 - s. Economizer controller shall provide indications when in free cooling mode, in the DCV mode, or the exhaust fan contact is closed.
6. Two-Position Damper (Factory-installed on 3 Phase Models Only. Field-installed on all 3 and 1 Phase Models):
- a. Damper shall be a Two-Position Motorized Damper. Damper travel shall be from the full closed position to the field adjustable %-open setpoint.
 - b. Damper shall include adjustable damper travel from 25% to 100% (full open).
 - c. Damper shall include single or dual blade, gear driven dampers and actuator motor.
 - d. Actuator shall be direct coupled to damper gear. No linkage arms or control rods shall be acceptable.
 - e. Damper will admit up to 100% outdoor air for applicable rooftop units.
 - f. Damper shall close upon indoor (evaporator) fan shutoff and/or loss of power.
 - g. The damper actuator shall plug into the rooftop unit's wiring harness plug. No hard wiring shall be required.
 - h. Outside air hood shall include aluminum water entrainment filter.
7. Manual damper:
Manual damper package shall consist of damper, air inlet screen, and rain hood which can be preset to admit up to 50% outdoor air for year round ventilation.
8. Humidi-MiZer® Adaptive Dehumidification System:
- a. The Humidi-MiZer Adaptive Dehumidification System shall be factory-installed and shall provide greater dehumidification of the occupied space by two modes of dehumidification operations beside its normal design cooling mode:
 - 1) Subcooling mode further subcools the hot liquid refrigerant leaving the condenser coil when both temperature and humidity in the space are not satisfied.
 - 2) Hot gas reheat mode shall mix a portion of the hot gas from the discharge of the compressor with the hot liquid refrigerant leaving the condenser coil to create a two-phase heat transfer in the system, resulting in a neutral leaving-air temperature when only humidity in the space is not satisfied.
 - 3) Includes head pressure controller.
9. Head pressure control package (Motormaster®):
- a. Controller shall control coil head pressure by condenser fan speed modulation or condenser fan cycling and wind baffles.
 - b. Shall consist of solid state control and condenser coil temperature sensor to maintain condensing temperature between 90°F (32°C) and 110°F (43°C) at outdoor ambient temperatures down to -20°F (-29°C).
10. Low Ambient Controller (Factory-installed only):
- a. Controller shall control coil head pressure by condenser-fan speed modulation or condenser-fan cycling and wind baffles.
 - b. Shall consist of solid-state control and condenser-coil temperature sensor to maintain condensing temperature between 90°F

(32°C) and 110°F (43°C) at outdoor ambient temperatures down to 0°F (-18°C).

11. Condenser Coil Hail Guard Assembly (Factory-installed option on 3 phase models. Field-installed on all 3 and 1 phase models):
 - a. Shall protect against damage from hail.
 - b. Shall be louvered style design.
12. Unit-mounted, non-fused disconnect switch:
 - a. Switch shall be factory-installed, internally mounted.
 - b. National Electric Code (NEC) and UL approved non-fused switch shall provide unit power shutoff.
 - c. Shall be accessible from outside the unit.
 - d. Shall provide local shutdown and lockout capability.
 - e. Sized only for the unit as ordered from the factory. Does not accommodate field-installed devices.
13. HACR Breaker:
 - a. These manual reset devices provide overload and short circuit protection for the unit. Factory wired and mounted with the units, with access cover to help provide environmental protection. On 575V applications, HACR breaker can only be used with WYE power distribution systems. Use on Delta power distribution systems is prohibited.
 - b. Sized only for the unit as ordered from the factory. Does not accommodate field-installed devices.
14. Convenience outlet:
 - a. Powered convenience outlet. (Not available on single phase models):
 - 1) Outlet shall be powered from main line power to the rooftop unit.
 - 2) Outlet shall be powered from line side or load side of disconnect by installing contractor, as required by code. If outlet is powered from load side of disconnect, unit electrical ratings shall be UL certified and rated for additional outlet amperage.
 - 3) Outlet shall be factory-installed and internally mounted with easily accessible 115-v female receptacle.
 - 4) Outlet shall include 15 amp GFI receptacles with independent fuse protection.
 - 5) Voltage required to operate convenience outlet shall be provided by a factory-installed step down transformer.
 - 6) Outlet shall be accessible from outside the unit.
 - 7) Outlet shall include a field-installed "Wet in Use" cover.
 - b. Factory-installed non-powered convenience outlet:
 - 1) Outlet shall be powered from a separate 115-120v power source.
 - 2) A transformer shall not be included.
 - 3) Outlet shall be factory-installed and internally mounted with easily accessible 115-v female receptacle.
 - 4) Outlet shall include 15 amp GFI receptacles.
 - 5) Outlet shall be accessible from outside the unit.
 - 6) Outlet shall include a field-installed "Wet in Use" cover.
 - c. Field-installed non-powered convenience outlet:
 - 1) Outlet shall be powered from a separate 115-120v power source.
 - 2) A transformer shall not be included.
 - 3) Outlet shall be field-installed and internally mounted with easily accessible 115-v female receptacle.
 - 4) Outlet shall include 20 amp GFI receptacles. This kit provides a flexible installation method which allows code compliance for height requirements of the GFCI outlet from the finished roof surface as well as the capability to relocate the outlet to a more convenient location.
 - 5) Outlet shall be accessible from outside the unit.
 - 6) Outlet shall include a field-installed "Wet in Use" cover.
15. Fan/Filter Status Switch:
 - a. Switch shall provide status of indoor evaporator fan (ON/OFF) or filter (CLEAN/DIRTY).
 - b. Status shall be displayed either over communication bus (when used with direct digital controls) or with an indicator light at the thermostat.
16. Thru-the-base connectors:
 - a. Kits shall provide connectors to permit electrical connections to be brought to the unit through the unit basepan.
 - b. Minimum of three connection locations per unit.
17. Propeller power exhaust:
 - a. Power exhaust shall be used in conjunction with an integrated economizer.
 - b. Independent modules for vertical or horizontal return configurations shall be available.
 - c. Horizontal power exhaust shall be mounted in return ductwork.
 - d. Power exhaust shall be controlled by economizer controller operation. Exhaust fans shall be energized when dampers open past

the 0-100% adjustable setpoint on the economizer control.

18. Roof curbs (vertical):
 - a. Full perimeter roof curb with exhaust capability providing separate air streams for energy recovery from the exhaust air without supply air contamination.
 - b. Formed galvanized steel with wood nailer strip and shall be capable of supporting entire unit weight.
 - c. Permits installation and securing of ductwork to curb prior to mounting unit on the curb.
19. Adapter Curb (Vertical):
 - a. Full perimeter, fully assembled and welded roof curb with exhaust capability providing separate air streams for energy recovery from the exhaust air without supply air contamination.
 - b. Formed galvanized steel with wood nailer strip and shall be capable of supporting entire unit weight.
 - c. Permits installation of new 50HC 17-28 models to past Carrier design curb models: DP,DR,HJ,TM, and TJ. Check with Carrier sales expert of further details and information.
20. Outdoor air enthalpy sensor:
 - a. The outdoor air enthalpy sensor shall be used to provide single enthalpy control. When used in conjunction with a return air enthalpy sensor, the unit will provide differential enthalpy control. The sensor allows the unit to determine if outside air is suitable for free cooling.
21. Return air enthalpy sensor:
 - a. The return air enthalpy sensor shall be used in conjunction with an outdoor air enthalpy sensor to provide differential enthalpy control.
22. Indoor air quality (CO₂) sensor:
 - a. Shall be able to provide demand ventilation indoor air quality (IAQ) control.
 - b. The IAQ sensor shall be available in duct mount, wall mount, or wall mount with LED display. The setpoint shall have adjustment capability.
23. CO₂ sensor (EnergyX):
 - a. The modulating airflow energy recovery unit shall be capable of incorporating a CO₂ sensor for use with Demand Controlled Ventilation.
 - b. The CO₂ sensor shall connect to the base rooftop unit's digital controller.
 - c. The modulating airflow energy recovery unit shall use at a minimum, a high and low CFM airflow set point when a CO₂ sensor is used.
24. Smoke detectors:
 - a. Shall be a four-wire controller and detector.
 - b. Shall be environmental compensated with differential sensing for reliable, stable, and drift-free sensitivity.
 - c. Shall use magnet-activated test/reset sensor switches.
 - d. Shall have tool-less connection terminal access.
 - e. Shall have a recessed momentary switch for testing and resetting the detector.
 - f. Controller shall include:
 - 1) One set of normally open alarm initiation contacts for connection to an initiating device circuit on a fire alarm control panel.
 - 2) Two Form-C auxiliary alarm relays for interface with rooftop unit or other equipment.
 - 3) One Form-C supervision (trouble) relay to control the operation of the Trouble LED on a remote test/reset station.
 - 4) Capable of direct connection to two individual detector modules.
 - 5) Can be wired to up to 14 other duct smoke detectors for multiple fan shut-down applications.
25. Horn/Strobe Annunciator:
 - a. Provides an audible/visual signaling device for use with factory-installed option or field-installed accessory smoke detectors.
 - 1) Requires installation of a field-supplied 24-v transformer suitable for 4.2 VA (AC) or 3.0 VA (DC) per horn/strobe accessory.
 - 2) Requires field-supplied electrical box, North American 1-gang box, 2-in. (51 mm) x 4-in. (102 mm).
 - 3) Shall have a clear colored lens.
26. Winter start kit:
 - a. Shall contain a bypass device around the low pressure switch.
 - b. Shall be required when mechanical cooling is required down to 25°F (-4°C).
 - c. Shall not be required to operate on an economizer when below an outdoor ambient of 40°F (4°C).
27. Time guard:
 - a. Shall prevent compressor short cycling by providing a 5 minute delay (±2 minutes) before restarting a compressor after shut-down for any reason.
 - b. One device shall be required per compressor.
28. Condensate Overflow Switch:
 - a. This sensor and related controller monitors the condensate level in the drain pan and

shuts down compression operation when overflow conditions occur. It includes:

- 1) Indicator light - solid red (more than 10 seconds on water contact - compressors disabled), blinking red (sensor disconnected).
- 2) 10 second delay to break - eliminates nuisance trips from splashing or waves in pan (sensor needs 10 seconds of constant water contact before tripping).
- 3) Disables the compressor(s) operation when condensate plug is detected, but still allows fans to run for Economizer.

29. Electric Heat:

a. Heating Section:

- 1) Heater element open coil resistance wire, nickel-chrome alloy, 0.29 inches inside diameter, strung through ceramic insulators mounted on metal frame. Coil ends are staked and welded to terminal screw slots.
- 2) Heater assemblies are provided with integral fusing in the single point box (if applicable) for protection of internal heater circuits not exceeding 48 amps each. Electric heaters other than CRHEATER113B00-116B00 use 24v control side break/auto-reset or line-break/auto-reset limit switches to protect the unit against over-temperature situations. CRHEATER113B00-116B00 electric heater applications use a combination of 24v control side break/auto-reset, line-break/non-resettable "one shot" limit switches to protect the unit against over-temperature situations. All heaters use magnetic heater contactors (24 v coil) and terminal block all mounted in electric heater control

box (minimum 18 ga galvanized steel) attached to end of heater assembly.

30. Barometric Hood (Horizontal Economizer Applications):

- a. Shall be required when a horizontal economizer and barometric relief are required. Barometric relief damper must be installed in the return air (horizontal) duct work. This hood provides weather protection.

31. Hinged Access panels:

- a. Shall provide easy access through integrated quarter turn latches.
- b. Shall be on major panels of filter, control box, fan motor and compressor.

32. Display kit for variable frequency drive:

- a. Kit allows the ability to access the VFD controller programs to provide special setup capabilities and diagnostics.
- b. Kit contains display module and communication cable.
- c. Display Kit can be permanently installed in the unit or used on any SAV system VFD controller as needed.

33. California OSHPD Seismic Certification Label:

- a. Units meet the seismic capacity requirements of the International Code Council Evaluation Service (ICC-ES) document AC156 (Acceptance Criteria for Seismic Qualification by Shake-Table Testing of Nonstructural Components and Systems) and per International Building Code (IBC 2009) at an SDS (g) value of 2.00 $z/h=1.0$, $I_p=1.5$ and certified by independent structural engineers.
- b. Units shall include a certification label that meets the CA OSHPD Special Seismic Certification pre-approval labeling requirements on the external chassis of the unit.

