



Turn to the experts

## Product Data

# WeatherMaster® Gas Heat/Electric Cooling Packaged Rooftop Units 3 to 12.5 Nominal Tons



48HC Sizes 04 to 14  
Packaged Rooftop Units with Gas Heat and Optional  
EnergyX® Energy Recovery Ventilator

## Easy to install, maintain, and operate Carrier rooftop units are designed by customers for customers.

WeatherMaster® units up to 12.5 tons are specifically designed to fit on Carrier roof curbs that were installed back to 1989, which makes replacement easy and eliminates the need for curb adapters or changing utility connections.

Single-stage units deliver SEERs up to 15.6, EERs up to 13.0, and IEERs up to 13.0. Two-stage units deliver EERs up to 12.2, units with single speed indoor motors deliver IEERs up to 14.0, and units with 2-speed indoor fan motor deliver IEERs up to 16.0. All models are capable of either vertical or horizontal to meet nearly every light commercial application need.

The Carrier rooftop unit (RTU) was designed by customers for customers. With “no-strip” screw collars, handled access panels, and more the unit is easy to install, easy to maintain, and easy to use. Your new 3 to 12.5 ton WeatherMaster Carrier rooftop unit (RTU) provides optimum comfort and control from a packaged rooftop.

Value-added features include:

- optional EnergyX® system with energy recovery ventilator (ERV)
- optional Humidi-MiZer® adaptive dehumidification system for improved part load humidity performance
- Puron® refrigerant (R-410A)
- single point gas and electrical connection
- optional fully integrated and easy to use *ComfortLink* controls
- RTU Open controller for BACnet<sup>1</sup>, LonWorks<sup>2</sup>, Modbus<sup>3</sup> and Johnson Controls N2.
- optional fully insulated cabinet, with optional foil faced insulation
- high energy efficiency ratings may be eligible for local utility rebates (in most territories)
- TXV refrigerant metering system
- scroll compressors with internal line-break overload protection

1. BACnet is a registered trademark of ASHRAE (American Society of Heating, Refrigerating and Air-Conditioning Engineers).  
 2. LonWorks is a registered trademark of Echelon Corporation.  
 3. Modbus is a registered trademark of Schneider Electric.

## Installation ease

All WeatherMaster units are field-convertible to horizontal air flow, which makes it easy to adjust to unexpected job-site complications. Lighter units make for easy replacement. Simple, fast plug-in connections to the standard integrated terminal board. Clearly labeled connection points to reduce installation time. Also, a large control box provides room to work and room to mount Carrier accessory controls.

## Easy to maintain

Easy access handles by Carrier provide quick and easy access to all normally serviced components. Our “no-strip” screw system has superior holding power and guides screws into position while preventing the screw from stripping the unit’s metal.

## Easy to use

The optimized, central terminal board by Carrier puts all connections and troubleshooting points in one convenient place. Most low voltage connections are made to the same board and make it easy to access it. Carrier rooftops have high and low pressure switches, a filter drier, and 2-in. filters standard. Our optional digital controllers allow for seamless and simple integration to the most complex building network.

## Streamlined control and integration

Carrier controllers make connecting WeatherMaster rooftops into existing building automation systems easy. The units are compatible with conventional thermostat controls, Carrier

PremierLink™ communicating controls, ComfortLink controller, and Carrier RTU Open multi-protocol controller interface with BACnet, Johnson Controls N2, LonWorks, or Modbus protocols. WeatherMaster rooftops also seamlessly integrate with Carrier building system options like the Carrier VVT® zoning system, or the Carrier i-Vu® Building Automation System.

## Operating efficiency and flexibility

The 48HC rooftops exceed ASHRAE (American Society of Heating, Refrigerating, and Air-Conditioning Engineers) 90.1-2016, IECC (International Energy Conservation Code) IECC-2015 minimum efficiency requirements.

## Field convertible airflow (3 to 12.5 ton)

All WeatherMaster units are field-convertible to horizontal air flow, which makes it easy to adjust to unexpected jobsite complications. Being able to convert a unit from vertical airflow to horizontal also makes it easy to overcome jobsite complications. 12.5 ton models require a simple supply air duct cover to field convert from factory vertical to horizontal.

EnergyX models are limited to vertical return but supply can be field converted.

## Staged Air Volume (SAV™) Two-Speed Indoor Fan Control System with variable frequency drive (VFD)

Optional SAV system utilizes a variable frequency drive (VFD) to automatically adjust the indoor fan motor

# Table of contents

	Page
Features/Benefits . . . . .	2
Model Number Nomenclature . . . . .	4
Capacity Ratings . . . . .	5
Physical Data . . . . .	9
Options and Accessories . . . . .	16
Base Unit Dimensions . . . . .	22
Accessory Dimensions . . . . .	48
Selection Procedures . . . . .	51
Performance Data . . . . .	53
Fan Data . . . . .	76
Typical Wiring Diagrams . . . . .	95
Electrical Data . . . . .	100
Controls . . . . .	117
Application Data . . . . .	120
Guide Specifications . . . . .	125

speed between operating modes. Available on 2-stage cooling models 07-14 with electro-mechanical, ComfortLink, or RTU Open controls.

### Comfort control

Carrier's patented Humidi-MiZer adaptive dehumidification system is an all-inclusive factory installed option on gas heating/electric cooling and electric heat/electric cooling models. This system provides reliable, flexible operation to meet indoor part load sensible and latent requirements.

### EnergyX factory integrated rotary energy recovery ventilator (ERV)

Carrier's EnergyX ERV system is an all inclusive factory-integrated and tested ERV that provides a rotary complete energy wheel ERV. The EnergyX system provides the capability to hold/transfer sensible and latent energy from the exhaust airstream to improve energy savings and increase ventilation without increasing heating or cooling requirements; therefore expanding the envelope of operation on the 48 Series rooftop unit to meet year round comfort and energy conditions. Designed with energy savings in mind.

Energy recovery wheels rotate between the incoming outdoor airstream and the building exhaust stream. As the wheel rotates, it transfers heat and moisture from one airstream to the other. Resulting in the outdoor air being pre-conditioned, significantly reducing the capacity and energy needed from the mechanical HVAC system.

EnergyX® features:

- ComfortLink digital controls
- Up to 70-75% energy wheel effectiveness
- AHRI 1060 certified energy wheel
- Robust insulated wheel design
- Silica desiccant coated wheel media for enhanced moisture capabilities
- Removable wheel segments for easy cleaning
- Single point unit power
- Optional wheel defrost control for northern climates

- Optional integrated bypasses for free cooling

### AirXchange<sup>1</sup> energy recovery cassette

UL certified, AHRI listed, silica gel enthalpy desiccant wheels > 25-in. diameter are segmented for easy cleaning, washable with detergent and water, and have a 5-year standard limited warranty.

### Optimum performance

Thermostatic expansion valve (TXV) on each refrigerant circuit helps provide optimum performance across the entire unit operating range.

### Power exhaust

To aid in building pressure control Carrier EnergyX® systems include ECM power exhaust fans as standard. The ComfortLink controller integrates the power exhaust into ERV operation while also ensuring precise building pressure control.

### Moisture control

Carrier's EnergyX system provides the added benefit of significantly raising humidity level of incoming outdoor air in the winter and lowering humidity level of incoming outdoor air in the summer. This humidity control can eliminate additional equipment requirements, discomfort, health problems, and increase indoor air quality for a building.

### Humidi-MiZer® adaptive dehumidification system

Carrier's Humidi-MiZer adaptive dehumidification system is an all-inclusive factory-installed option that can be ordered with any WeatherMaster® 48HC04-14 rooftop unit (with the exception of single-phase voltage 208-230/1/60). This system expands the envelope of operation of operation of Carrier WeatherMaster rooftop products to provide unprecedented flexibility that will meet year-round comfort conditions.

WeatherMaster is the next generation version of Carrier's Humidi-MiZer system and includes modulating refrigerant valves that provide variable flow bypass around the condenser. This innovative feature ensures exact control of the supply-air temperature as the unit lowers the evaporator temperature to increase latent capacity.

The Humidi-MiZer adaptive dehumidification system has the industry's only dual dehumidification mode setting. The WeatherMaster rooftop, coupled with the Humidi-MiZer adaptive dehumidification system, is capable of operating in normal design cooling mode, sub-cooling mode, and hot gas reheat mode.

In the normal design cooling mode the unit will operate under the normal sequence of operation. The Humidi-MiZer system is inactive. In the sub-cooling mode the controller will control the refrigeration system to satisfy cooling and dehumidification requirements, as well as providing adequate reheat to maintain the desired supply-air temperature.

Hot gas reheat mode will operate when the space requires dehumidification only. The controller will control the refrigeration system to provide latent capacity similar to that provided in the full sub-cooling mode.

In addition, it can increase hot discharge gas bypass to the Humidi-MiZer coil in order to heat the air to the exact neutral state required - no over-cooling or overheating.

### OSHPD Special Seismic Certification

48HC units are certified by OSHPD (Office of Statewide Health Planning and Development) Special Seismic Certification Pre-approval (OSP). OSP is a special seismic certification that assures equipment shall maintain structural integrity and functionality during an earthquake. Supports and attachments are not certified.

OSHPD not available on units with factory installed Humidi-MiZer, HACR breaker, low ambient controls, hailguards, or EnergyX system.

---

1. AirXchange is a registered trademark of AirXchange, Inc.

## 48HC MODEL NUMBER NOMENCLATURE

48 HC D E 09 A 2 A 6 A 0 A 3 B 0

### Unit Heat Type

48 - Gas Heat Packaged Rooftop

### Model Series - WeatherMaster®

HC - High Efficiency

### Heat Options

D = Low Gas Heat  
 E = Medium Gas Heat  
 F = High Gas Heat  
 L = Low NOx - Low Gas Heat  
 M = Low NOx - Medium Gas Heat  
 N = Low NOx - High Gas Heat  
 S = Low Heat w/ Stainless Steel Exchanger  
 R = Medium Heat w/ Stainless Steel Exchanger  
 T = High Heat w/ Stainless Steel Exchanger  
 (Low NOx models include - Stainless Steel HX)

### Refrig. Systems Options

A = Single stage cooling models  
 B = Single stage cooling models with Humidi-MiZer®  
 D = Two stage cooling models  
 E = Two stage cooling models with Humidi-MiZer  
 F = Single stage cooling models with Motormaster® Low Ambient Controller  
 G = Two stage cooling models with Motormaster Low Ambient Controller

### Cooling Tons

04 - 3 ton	09 - 8.5 ton
05 - 4 ton	11 - 10 ton (12.0 EER)*
06 - 5 ton	12 - 10 ton (11.5 EER)*
07 - 6 ton	14 - 12.5 ton
08 - 7.5 ton	

### Sensor Options

A = None  
 B = RA Smoke Detector  
 C = SA Smoke Detector  
 D = RA + SA Smoke Detector  
 E = CO<sub>2</sub>  
 F = RA Smoke Detector and CO<sub>2</sub>  
 G = SA Smoke Detector and CO<sub>2</sub>  
 H = RA + SA Smoke Detector and CO<sub>2</sub>  
 J = Condensate Overflow Switch  
 K = Condensate Overflow Switch and RA Smoke Detectors  
 L = Condensate Overflow Switch and RA + SA Smoke Detectors

### Indoor Fan Options 3, 4, 5 Ton Models Only

0 = Electric (Direct) Drive x13 Motor  
 2 = Medium Static Option - Belt Drive  
 3 = High Static Option - Belt Drive

### Indoor Fan Options 6-12.5 Ton Models Only

1 = Standard Static Option - Belt Drive  
 2 = Medium Static Option - Belt Drive  
 3 = High Static Option - Belt Drive  
 C = High Static Option with High-Efficiency Motor, Belt Drive (Size 14 only)

### Coil Options (RTPF) (Outdoor - Indoor - Hail Guard)

A = Al/Cu - Al/Cu  
 B = Precoat Al/Cu - Al/Cu  
 C = E-coat Al/Cu - Al/Cu  
 D = E-coat Al/Cu - E-coat Al/Cu  
 E = Cu/Cu - Al/Cu  
 F = Cu/Cu - Cu/Cu  
 M = Al/Cu - Al/Cu — Louvered Hail Guard  
 N = Precoat Al/Cu - Al/Cu — Louvered Hail Guard  
 P = E-coat Al/Cu - Al/Cu — Louvered Hail Guard  
 Q = E-coat Al/Cu - E-coat Al/Cu — Louvered Hail Guard  
 R = Cu/Cu - Al/Cu — Louvered Hail Guard  
 S = Cu/Cu - Cu/Cu — Louvered Hail Guard

### Factory Assigned

0 = Standard  
 1 = LTL  
 3 = California Seismic Complaint - OSHPD  
 4 = California Seismic Complaint - OSHPD plus LTL

### Electrical Options†

A = None  
 B = HACR Breaker  
 C = Non-Fused Disconnect  
 D = Thru-The-Base Connections  
 E = HACR and Thru-The Base Connections  
 F = Non-Fused Disconnect and Thru-The-Base Connections  
 G = 2-Speed Indoor Fan (VFD) Controller  
 H = 2-Speed Fan Controller (VFD) and HACR Breaker  
 J = 2-Speed Fan Controller (VFD) and Non-Fused Disconnect  
 K = 2-Speed Fan Controller (VFD) and Thru-The-Base Connections  
 L = 2-Speed Fan Controller (VFD) w/ HACR Breaker and Thru-The Base Connections  
 M = 2-Speed Fan Controller (VFD) with Non-Fused Disconnect and Thru-The-Base Connections

### Service Options

0 = None  
 1 = Unpowered Convenience Outlet  
 2 = Powered Convenience Outlet  
 3 = Hinged Panels  
 4 = Hinged Panels and Unpowered Convenience Outlet  
 5 = Hinged Panels and Powered Convenience Outlet  
 C = Foil Faced Insulation  
 D = Foil Faced Insulation with Unpowered Convenience Outlet  
 E = Foil Faced Insulation with Powered Convenience Outlet  
 F = Foil Faced Insulation & Hinged Panels  
 G = Foil Faced Insulation & Hinged Panels with Unpowered Convenience Outlet  
 H = Foil Faced Insulation & Hinged Panels with Powered Convenience Outlet

### Intake / Exhaust Options

A = None  
 B = Temperature Economizer w/ Barometric Relief  
 F = Enthalpy Economizer w/ Barometric Relief  
 K = 2-Position Damper  
 Q = EnergyX® only  
 R = EnergyX + Economizer only\*\*  
 S = EnergyX + Frost Protection only\*\*  
 T = EnergyX + Economizer + Frost Protection\*\*  
 U = Low Leak Temperature Economizer w/ Barometric Relief  
 W = Low Leak Enthalpy Economizer w/ Barometric Relief

### Base Unit Controls

0 = Electromechanical Controls can be used with W7212 Controller (Non-Fault Detection and Diagnostic)  
 1 = PremierLink™ Controller  
 2 = RTU Open Multi-Protocol Controller  
 6 = Electro-mechanical w/ 2-speed fan and W7220 controller (w/ Fault Detection & Diagnostic). Can be used with EconoMiSer®  
 D = ComfortLink Controls (Not available on 2-stage cooling 07 size models or size 11 with Humidi-Mizer®)

### Design Revision

A = Factory Design Revision

### Voltage††

1 = 575/3/60	5 = 208-230/3/60
3 = 208-230/1/60	6 = 460/3/60

\* Staged Air Volume (SAV) is required on sizes 11 and 12 units to meet DOE-2018 minimum efficiency requirements.

† Units sold in the US require a 2-speed fan.

\*\* Includes ComfortLink controls.

†† On single phase models (-3 voltage code), the following are not available as factory-installed options:

- Humidi-MiZer System
- Coated Coils or Cu Fin Coils
- Louvered Hail Guards
- Economizer or 2-Position Damper
- Powered 115 v Convenience Outlet



For California Residents:  
 For installation in SCAQMD only: This furnace does not meet the SCAQMD Rule 1111 14 ng/J NOx emission limit, and thus is subject to a mitigation fee of up to \$450. This furnace is not eligible for the Clean Air Furnace Rebate Program: [www.CleanAirFurnaceRebate.com](http://www.CleanAirFurnaceRebate.com).

## AHRI RATINGS (1-STAGE COOLING)

48HC UNIT	COOLING STAGES	NOMINAL CAPACITY (TONS)	NET COOLING CAPACITY (MBH)	TOTAL POWER (kW)	SEER	EER	IEER
A04	1	3	35.4	2.8	15.00	12.50	N/A
A05	1	4	48.5	3.7	15.60	13.00	N/A
A06	1	5	57.5	4.6	15.20	12.45	N/A
A07	1	6	73.0	6.0	N/A	12.00	13.00

### LEGEND

**AHRI** — Air-Conditioning, Heating and Refrigeration Institute  
**COP** — Coefficient of Performance  
**EER** — Energy Efficiency Ratio  
**IEER** — Integrated Energy Efficiency Ratio  
**SEER** — Seasonal Energy Efficiency Ratio

### NOTES:

- Rated in accordance with AHRI Standards 210/240 (04-06 size) and 340/360 (07-14 size).
- Ratings are based on:  
**Cooling Standard:** 80°F (27°C) db, 67°F (19°C) wb indoor air temp and 95°F (35°C) db outdoor air temp.  
**IEER Standard:** A measure that expresses cooling part-load EER efficiency for commercial unitary air-conditioning and heat pump equipment on the basis of weighted operation at various load capacities.
- All 48HC units comply with ASHRAE 90.1-2016 (American Society of Heating, Refrigeration, and Air-Conditioning Engineers) and DOE-2018 (Department of Energy) Energy Standard for minimum SEER and EER requirements.
- 48HC units comply with US Energy Policy Act (2005). To evaluate code compliance requirements, refer to state and local codes.



## AHRI RATINGS (2-STAGE COOLING)

48HC UNIT	COOLING STAGES	NOMINAL CAPACITY (TONS)	NET COOLING CAPACITY (MBH)	TOTAL POWER (kW)	EER	IEER WITH SINGLE SPEED INDOOR MOTOR	IEER WITH 2-SPEED INDOOR MOTOR
D07	2	6.0	72.0	6.0	12.0	14.0	16.0
D08	2	7.5	89.0	7.4	12.0	13.0	13.8
D09	2	8.5	97.0	8.1	12.0	13.0	13.8
D11*	2	10.0	111.0	9.3	12.0	12.6	14.3
D12*	2	10.5	115.0	10.0	11.5	12.0	12.7
D14	2	12.5	146.0	11.9	12.2	13.0	13.9

### LEGEND

**AHRI** — Air-Conditioning, Heating and Refrigeration Institute  
**COP** — Coefficient of Performance  
**EER** — Energy Efficiency Ratio  
**IEER** — Integrated Energy Efficiency Ratio  
**SEER** — Seasonal Energy Efficiency Ratio

\* 2-speed fan is required to meet DOE-2018 standards.

### NOTES:

- Rated in accordance with AHRI Standards 210/240 (04-06 size) and 340/360 (07-14 size).
- Ratings are based on:  
**Cooling Standard:** 80°F (27°C) db, 67°F (19°C) wb indoor air temp and 95°F (35°C) db outdoor air temp.  
**IEER Standard:** A measure that expresses cooling part-load EER efficiency for commercial unitary air-conditioning and heat pump equipment on the basis of weighted operation at various load capacities.
- All 48HC units comply with ASHRAE 90.1-2016 (American Society of Heating, Refrigeration, and Air-Conditioning Engineers) and DOE-2018 (Department of Energy) Energy Standard for minimum SEER and EER requirements.
- 48HC units comply with US Energy Policy Act (2005). To evaluate code compliance requirements, refer to state and local codes.



## SOUND RATINGS TABLE

48HC UNIT	COOLING STAGES	OUTDOOR SOUND (dB) AT 60 HZ								
		A-WEIGHTED	63	125	250	500	1000	2000	4000	8000
A04	1	76	78.2	78.0	74.2	73.3	70.6	66.0	62.4	56.9
A05	1	78	84.7	83.6	77.1	74.6	72.3	68.3	64.7	60.9
A06	1	77	87.5	82.5	76.1	73.6	71.3	67.1	64.1	60.0
A07	1	82	90.1	82.6	81.0	79.4	77.0	73.0	70.4	66.7
D07	2	82	90.1	82.6	81.0	79.4	77.0	73.0	70.4	66.7
D08	2	82	90.6	84.3	80.2	79.3	77.1	72.2	67.4	63.7
D09	2	82	88.6	85.0	81.6	79.5	77.4	74.1	71.0	66.3
D11	2	87	85.9	87.9	85.6	84.4	82.8	78.5	74.9	72.5
D12	2	87	85.9	87.9	85.6	84.4	82.8	78.5	74.9	72.5
D14	2	83	89.3	86.0	82.9	80.7	78.5	73.6	69.6	64.5

### LEGEND

**dB** — Decibel

### NOTES:

1. Outdoor sound data is measured in accordance with AHRI.
2. Measurements are expressed in terms of sound power. Do not compare these values to sound pressure values because sound pressure depends on specific environmental factors which normally do not match individual applications. Sound power values are independent of the environment and therefore more accurate.
3. A-weighted sound ratings filter out very high and very low frequencies, to better approximate the response of "average" human ear. A-weighted measurements for Carrier units are taken in accordance with AHRI.



**MINIMUM - MAXIMUM AIRFLOW RATINGS (CFM) — NATURAL GAS AND PROPANE**

VOLTAGE	48HC UNIT	HEAT LEVEL	COOLING				HEATING*		
			Minimum Single Speed Fan Motor	Minimum 2-Speed Fan Motor (at high speed)	Minimum 2-Speed Fan Motor (at low speed)	Maximum	Minimum	Maximum	
Single Phase	04	LOW	900	—	—	1500	900	1970	
		MED					800	1520	
		HIGH					—	—	
Single Phase	05	LOW	1200	—	—	2000	900	2470	
		MED					1050	2280	
		HIGH					1230	2190	
Single Phase	06	LOW	1500	—	—	2500	900	3290	
		MED					1050	2730	
		HIGH					1230	2820	
Three Phase	04	LOW	900	—	—	1500	990	2190	
		MED					1010	1550	
		HIGH					—	—	
	Three Phase	05	LOW	1200	—	—	2000	990	2190
			MED					1330	2460
			HIGH					1390	2220
	Three Phase	06	LOW	1500	—	—	2500	990	2730
			MED					1330	2880
			HIGH					1390	2780
Three Phase	07	LOW	1800	1800	1200	3000	990	3640	
		MED					1330	4750	
		HIGH					1390	3750	
Three Phase	08	LOW	2250	2535	1673	3750	1900	4750	
		MED					2100	3900	
		HIGH					2270	3780	
Three Phase	09	LOW	2550	2550	1683	4250	1900	4750	
		MED					2100	4560	
		HIGH					2270	4250	
Three Phase	11	LOW	3000	3380	2231	5000	1900	4750	
		MED					2100	4560	
		HIGH					2270	4250	
Three Phase	12	LOW	3000	3380	2231	5000	2100	5470	
		MED					2620	5670	
		HIGH					2650	5290	
Three Phase	14	LOW	3750	4225	2789	6250	1880	7500	
		MED					2450	6750	
		HIGH					3000	7200	

— Not Available

\* Heating rating values are identical for aluminum heat exchangers and stainless steel heat exchangers.

## HEAT RATING TABLE — NATURAL GAS AND PROPANE

48HC UNIT		GAS HEAT	AL/SS HEAT EXCHANGER		TEMPERATURE RISE (F)	THERMAL EFFICIENCY (%)	AFUE (%)
			INPUT/OUTPUT STAGE 1 (MBH)	INPUT/OUTPUT STAGE 2 (MBH)			
Single Phase	04	LOW	—	65/53	25 - 55	82	81.0
		MED	—	90/73.5	45 - 85	82	81.2
		HIGH	—	—	—	—	—
	05	LOW	—	65/53	20 - 55	82	81.0
		MED	—	90/73.5	30 - 65	82	81.2
		HIGH	—	130/106	45 - 80	82	81.0
	06	LOW	—	65/53	15 - 55	82	81.0
		MED	—	90/73.5	25 - 65	82	81.2
		HIGH	—	130/106	35 - 80	82	81.0
Three Phase	04	LOW	50/41	72/56	25 - 25	82	—
		MED	82/66	115/89	55 - 85	80	—
		HIGH	—	—	—	—	—
	05	LOW	50/41	72/56	25 - 55	82	—
		MED	82/66	115/90	35 - 65	81	—
		HIGH	120/96	150/117	50 - 80	80	—
	06	LOW	50/41	72/56	20 - 55	82	—
		MED	82/66	115/90	30 - 65	81	—
		HIGH	120/96	150/117	40 - 80	80	—
	07	LOW	50/41	72/59	15 - 55	82	—
		MED	82/66	125/103	20 - 50	82	—
		HIGH	120/96	150/120	30 - 60	81	—
	08	LOW	50/41	125/103	20 - 50	82	—
		MED	90/73	180/148	35 - 65	82	—
		HIGH	105/84	224/184	45 - 75	82	—
	09	LOW	90/73	125/103	20 - 50	82	—
		MED	120/98	180/148	30 - 65	82	—
		HIGH	180/147	224/184	40 - 75	82	—
	12	LOW	120/98	180/148	25 - 65	82	—
		MED	180/147	224/184	30 - 65	82	—
		HIGH	200/160	250/205	35 - 70	80	—
	14	LOW	120/96	150/120	15 - 60	80	—
		MED	144/118	180/146	20 - 55	81	—
		HIGH	192/156	240/195	25 - 60	81	—

**NOTES:**

- Heat ratings are for natural gas heat exchangers operated at or below 2000 ft (610 m). For information on Propane or altitudes above 2000 ft (610 m), see the Application Data section of this book. Accessory Propane/High Altitude kits are also available.
- The input rating for altitudes above 2000 ft (610m) must be derated by 4% for each 1000 ft (305 m) above sea level.

## HEAT RATING TABLE — LOW NO<sub>x</sub>\*

48HC UNIT		GAS HEAT	AL/SS HEAT EXCHANGER		TEMPERATURE RISE (F)	THERMAL EFFICIENCY (%)	AFUE (%)
			INPUT/OUTPUT STAGE 1 (MBH)	INPUT/OUTPUT STAGE 2 (MBH)			
Single Phase	04	LOW	—	60/49	20-50	81	81.0
		MED	—	90/73.5	30-60	81	81.2
		HIGH	—	—	—	—	—
	05	LOW	—	60/49	20-50	81	81.0
		MED	—	90/73.5	30-60	81	81.2
		HIGH	—	120/98	40-70	81	81.0
	06	LOW	—	60/49	15-50	81	81.0
		MED	—	90/73.5	25-60	80	81.2
		HIGH	—	120/98	35-70	80	81.0
Three Phase	04	LOW	—	60/49	20-50	81	—
		MED	—	90/73.5	30-60	81	—
		HIGH	—	—	—	—	—
	05	LOW	—	60/49	20-50	81	—
		MED	—	90/73.5	30-60	81	—
		HIGH	—	120/98	40-70	81	—
	06	LOW	—	60/49	15-50	81	—
		MED	—	90/73.5	25-60	80	—
		HIGH	—	120/98	35-70	80	—

\* Units meet California's South Coast Air Quality Management District (SCAQMD) Low-NO<sub>x</sub> emissions requirement of 40 nanograms per joule or less.



## 48HC 3 TO 6 TON PHYSICAL DATA

48HC UNIT	48HC**04	48HC**05	48HC**06	48HC**07
<b>NOMINAL TONS</b>	3	4	5	6
<b>BASE UNIT OPERATING WT (lb)*</b>	505	590	600	925
<b>REFRIGERATION SYSTEM</b>				
<b>No. Circuits/No. Compressors/Type</b>	1/1/Scroll	1/1/Scroll	1/1/Scroll	1/1/2-Stage Scroll
<b>Puron® Refrigerant Charge (lb-oz)</b>	9-0	12-8	13-8	14-0
<b>Humidi-Mizer® Puron Refrigerant Charge</b>	11-0	19-12	20-0	22-8
<b>Metering Device</b>	TXV			
<b>High Pressure Trip/Reset (psig)</b>	630/505			
<b>Low Pressure Trip/Reset (psig)</b>	54/117			
<b>EVAPORATOR COIL</b>				
<b>Material (Tube Fin)</b>	Cu/Al			
<b>Coil Type</b>	<sup>3</sup> / <sub>8</sub> -in. RTPF			
<b>Rows/FPI</b>	3/15	3/15	4/15	3/15
<b>Total Face Area (ft<sup>2</sup>)</b>	5.5	7.3	7.3	8.9
<b>Condensate Drain Connection Size</b>	<sup>3</sup> / <sub>4</sub> -in.			
<b>HUMIDI-MIZER COIL</b>				
<b>Material (Tube Fin)</b>	Cu/Al			
<b>Coil Type</b>	<sup>3</sup> / <sub>8</sub> -in. RTPF			
<b>Rows/FPI</b>	1/17	2/17	2/17	2/17
<b>Total Face Area (ft<sup>2</sup>)</b>	3.9	5/2	5/2	5/2
<b>ENERGYX RECOVERY WHEEL</b>				
<b>Type</b>	Enthalpy Lightweight Polymer with Silica Gel Desiccant Coating			
<b>Model (AirXchange)</b>	ERC-1904	ERC-2513C	ERC-2513C	ERC-2513C
<b>Size (Dia. x Depth) (in.)</b>	19 x 1	25 x 3	25 x 3	25 x 3
<b>Nominal Drive Motor Hp</b>	0.1	0.1	0.1	0.1
<b>ENERGYX SUPPLY FAN #1</b>				
<b>Qty - Type</b>	1 - Backward Curved			
<b>Drive Type</b>	Direct			
<b>Blower Size (Diameter) [in. (mm)]</b>	9.8 (250)	15.75 (400)	15.75 (400)	15.75 (400)
<b>Nominal Motor Hp</b>	0.2	1.2	1.2	1.2
<b>ENERGYX EXHAUST FAN #1</b>				
<b>Qty - Type</b>	1 - Backward Curved			
<b>Drive Type</b>	Direct			
<b>Blower Size [in. (mm)]</b>	15.75 (400)			
<b>Nominal Motor Hp</b>	1.2			
<b>ENERGYX WHEEL FILTERS</b>				
<b>TYPE</b>	2-in. Pleated, 30% Efficiency			
<b>Outside Air (Qty) - Size (in.)</b>	(1) 10 x 20 x 2	(1) 16 x 25 x 2	(1) 16 x 25 x 2	(1) 16 x 25 x 2
<b>Exhaust Air (Qty) - Size (in.)</b>	(1) 10 x 20 x 2	(1) 16 x 25 x 2	(1) 16 x 25 x 2	(1) 16 x 25 x 2
<b>TYPE</b>	Aluminum Water Filter			
<b>Water Entrapment (Qty) - Size (in.)</b>	(1) 28.75 x 12.25 x 1	(1) 28.75 x 14.75 x 1		(1) 35.75 x 15.25 x 1

See legend on page 12.

## 48HC 3 TO 6 TON PHYSICAL DATA (cont)

48HC UNIT	48HC**04	48HC**05	48HC**06	48HC**07
<b>EVAPORATOR FAN MOTOR†</b>				
<b>STANDARD STATIC 1 PHASE (DIRECT DRIVE)</b>				
Motor Quantity/Drive Type		1/Direct		—
Max BHP		1.0		—
RPM Range		600-1200		—
Motor Frame Size		48		—
Fan Quantity/Type		1/Centrifugal		—
Fan Diameter (in.)		10 x 10		—
<b>STANDARD STATIC 1 PHASE (BELT DRIVE)</b>				
Motor Quantity/Drive Type	1/Belt		1/Belt	—
Max BHP	1.2		1.2	—
RPM Range	560-854		770-1175	—
Motor Frame Size	48		48	—
Fan Quantity/Type	1/Centrifugal		1/Centrifugal	—
Fan Diameter (in.)	10 x 10		10 x 10	—
<b>STANDARD STATIC 3 PHASE (DIRECT DRIVE)**</b>				
Motor Quantity/Drive Type	1/Direct		1/Direct	1/Belt
Max BHP	1.0		1.0	1.7
RPM Range	600-1200		600-1200	489-747
Motor Frame Size	48		48	56
Fan Quantity/Type	1/Centrifugal		1/Centrifugal	1/Centrifugal
Fan Diameter (in.)	10 x 10		11 x 10	15 x 15
<b>STANDARD STATIC 3 PHASE (BELT DRIVE)**</b>				
Motor Quantity/Drive Type	1/Belt		1/Belt	—
Max BHP	1.2		1.2	—
RPM Range	560-854		770-1175	—
Motor Frame Size	48		48	—
Fan Quantity/Type	1/Centrifugal		1/Centrifugal	—
Fan Diameter (in.)	10 x 10		10 x 10	—
<b>MEDIUM STATIC 1 PHASE</b>				
Motor Quantity/Drive Type	1/Belt		1/Belt	—
Max BHP	1.2		1.2	—
RPM Range	770-1175		1035-1466	—
Motor Frame Size	48		56	—
Fan Quantity/Type	1/Centrifugal		1/Centrifugal	—
Fan Diameter (in.)	10 x 10		10 x 10	—
<b>MEDIUM STATIC 3 PHASE**</b>				
Motor Quantity/Drive Type		1/Belt		
Max BHP	1.7	1.7	2.4	2.9
RPM Range	770-1175	920-1303	1035-1466	733-949
Motor Frame Size	48	56	56	56
Fan Quantity/Type		1/Centrifugal		
Fan Diameter (in.)	10x10	10x10	10x10	15x15

See legend on page 12.



### 48HC 3 TO 6 TON PHYSICAL DATA (cont)

48HC UNIT	48HC**04	48HC**05	48HC**06	48HC**07
<b>HIGH STATIC 3 PHASE</b>				
Motor Quantity/Drive Type	1/Belt			
Max BHP	2.4	2.9	2.9	4.7
RPM Range	1035-1466	1208-1639	1303-1687	909-1102
Motor Frame Size	56	56	56	14
Fan Quantity/Type	1/Centrifugal			
Fan Diameter (in.)	10x10	10x10	10x10	15x15
<b>CONDENSER COIL</b>				
Material (Tube/Fin)	Cu/Al	Cu/Al	Cu/Al	Cu/Al
Coil Type	3/8-in. RTPF	3/8-in. RTPF	3/8-in. RTPF	3/8-in. RTPF
Rows/FPI	2/17	2/17	2/17	2/17
Total Face Area (ft <sup>2</sup> )	12.7	21.3	21.3	20.5
<b>CONDENSER FAN/MOTOR</b>				
Quantity/Motor Drive Type	1/Direct			
Motor HP/RPM	1/8 / 825	1/4 / 1100	1/4 / 1100	1/4 / 1100
Fan Diameter (in.)	22	22	22	22
<b>FILTERS</b>				
RA Filter Qty / Size (in.)	2 / 16x25x2	1 / 16x16x2	4 / 16x16x2	4 / 16x20x2
OA Inlet Screen #/Size (in.)	1 / 20x24x1	1 / 20x24x1	1 / 20x24x1	1 / 20x36x1
<b>GAS CONNECTION</b>				
Number of Gas Valves	1			
Natural Gas Supply Line Pressure (in. wg)/(psig)	4-13 / 0.18-0.47			
Propane Supply Line Pressure (in. wg)/(psig)	11-13 / 0.40-0.47			
<b>HEAT ANTICIPATOR SETTING (AMPS)</b>				
First Stage	0.14			
Second Stage	0.14			
<b>NATURAL GAS HEAT</b>				
<b>LOW</b>				
Number of Stages / Number of Burners (total)	1 or 2 / 2			2 / 2
Connection Size	1/2 in. NPT			1/2 in. NPT
Rollout Switch Opens / Closes (F)	195/115			195/115
Temperature Rise Range (F)	25-55	20-55   25-55††	15-55   20-55††	15-55
<b>MEDIUM</b>				
Number of Stages / Number of Burners (total)	1 or 2 / 3			2 / 3
Connection Size	1/2 in. NPT			1/2 in. NPT
Rollout Switch Opens / Closes (F)	195/115			195/115
Temperature Rise Range (F)	45-85   25-55†	30-65   25-55††	25-65   20-55††	20-50
<b>HIGH</b>				
Number of Stages / Number of Burners (total)	—	1 or 2 / 3		2/4
Connection Size	—	1/2 in. NPT		3/4 in. NPT
Rollout Switch Opens / Closes (F)	—	195 / 115		195 / 115
Temperature Rise Range (F)	—	45-80   50-80††	35-80   40-80††	30-60

See legend on page 12.

## 48HC 3 TO 6 TON PHYSICAL DATA (cont)

48HC UNIT	48HC**04	48HC**05	48HC**06	48HC**07
<b>LIQUID PROPANE HEAT</b>				
<b>LOW</b>				
Number of Stages / Number of Burners (total)	1 or 2 / 2			2 / 2
Connection Size	1/2 in. NPT			1/2-in. NPT
Rollout Switch Opens / Closes (F)	195 / 115			195 / 115
Temperature Rise Range (F)	25 - 55	25 - 55†	20 - 55   25 - 55††	15 - 55
<b>MEDIUM</b>				
Number of Stages / Number of Burners (total)	1 or 2 / 3			2 / 3
Connection Size	1/2 in. NPT			1/2-in. NPT
Rollout Switch Opens / Closes (F)	195/115			195 / 115
Temperature Rise Range (F)	45 - 85	55 - 85†	30 - 65   35 - 65††	20 - 50
<b>HIGH</b>				
Number of Stages / Number of Burners (total)	—	1 or 2/3		2 / 4
Connection Size	—	1/2- n. NPT		1/2- n. NPT
Rollout Switch Opens / Closes (F)	—	195/115		195/115
Temperature Rise Range (F)	—	45-80	50-80††	30-60
<b>LOW NO<sub>x</sub> GAS HEAT</b>				
<b>LOW</b>				
Number of Stages / Number of Burners (total)	1 or 2/2			—
Connection Size	1/2 in. NPT			—
Rollout Switch Opens / Closes (F)	195 / 115			—
Temperature Rise Range (F)	25 - 55	20 - 55	15 - 55	—
<b>MEDIUM</b>				
Number of Stages / Number of Burners (total)	1 or 2/2			—
Connection Size	1/2 in. NPT			—
Rollout Switch Opens / Closes (F)	195 / 115			—
Temperature Rise Range (F)	30 - 60	30 - 60	25 - 60	—
<b>HIGH</b>				
Number of Stages / Number of Burners (total)	—	1 or 2/3		—
Connection Size	—	1/2 in. NPT		—
Rollout Switch Opens / Closes (F)	—	195 / 115		—
Temperature Rise Range (F)	—	40 - 70	35 - 70	—

### LEGEND

**BHP** — Brake Horsepower  
**FPI** — Fins Per Inch  
**OA** — Outdoor Air  
**RA** — Return Air  
**RTPF** — Round Tube, Plate Fin  
**TXV** — Thermostatic Expansion Valve  
 — — Not Available

\* Base unit operating weight does not include weight of options.  
 † Humidi-MiZer® requires belt drive type.  
 \*\* Humidi-MiZer® models only.  
 †† Three phase units only.



### 48HC 7.5 TO 12.5 TON PHYSICAL DATA

48HC UNIT	48HC**08	48HC**09	48HC**11	48HC**12	48HC**14
<b>NOMINAL TONS</b>	7.5	8.5	10	10	12.5
<b>BASE UNIT OPERATING WT (lb)*</b>	925	925	1090	1090	1430
<b>REFRIGERATION SYSTEM</b>					
No. Circuits/No. Compressors/Type	2 / 2 / Scroll	2 / 2 / Scroll	2 / 2 / Scroll	2 / 2 / Scroll	2 / 2 / Scroll
Puron® Refrigerant Charge A/B (lb-oz)	9-10 / 9-10	9-14 / 9-14	12-10 / 13-0	12-11 / 12-5	16-7 / 15-5
Humidi-MiZer® Puron Refrigerant Charge A/B	17-0 / 17-0	15-2 / 15-2	18-0 / 18-0	18-3 / 17-3	25-8 / 22-8
Metering Device	TXV				
High Pressure Trip/Reset (psig)	630 / 505				
Low Pressure Trip/Reset (psig)	54 / 117				
Compressor Capacity Staging (%)	50% / 100%				
<b>EVAPORATOR COIL</b>					
Material (Tube Fin)	Cu / Al	Cu / Al	Cu / Al	Cu / Al	Cu / Al
Coil Type	3/8-in. RTPF	3/8-in. RTPF	3/8-in. RTPF	3/8-in. RTPF	3/8-in. RTPF
Rows/FPI	4 / 15	4 / 15	4 / 15	4 / 15	4 / 15
Total Face Area (ft²)	11.1	11.1	11.1	11.1	17.5
Condensate Drain Connection Size	3/4-in.	3/4-in.	3/4-in.	3/4-in.	3/4-in.
<b>HUMIDI-MIZER COIL</b>					
Material (Tube Fin)	Cu / Al	Cu / Al	Cu / Al	Cu / Al	Cu / Al
Coil Type	3/8-in. RTPF	3/8-in. RTPF	3/8-in. RTPF	3/8-in. RTPF	3/8-in. RTPF
Rows/FPI	2 / 17	2 / 17	2 / 17	2 / 17	1 / 17
Total Face Area (ft²)	6.3	8.4	8.6	8.6	13.8
<b>ENERGYX UNIT TYPE</b>	Modulating Air Flow Capacity				
<b>ENERGYX WHEEL MAXIMUM AIRFLOW (CFM)</b>	900-2000				
<b>ENERGYX RECOVERY WHEEL</b>					
Type	Enthalpy Lightweight Polymer with Silica Gel Desiccant Coating				
Model (AirXchange)	ERC-3019C				ERC-3628C
Size (dia x depth)	30 x 3				36 x 3
Nominal Drive Motor HP	0.1				1/20
<b>ENERGYX SUPPLY FAN</b>					
Qty - Type	1 — Backward Curve				
Drive Type	Direct				
Blower Size (dia) [in. (mm)]	15.75 (400)				
Nominal Motor HP	1.179				3.7
<b>ENERGYX EXHAUST FAN</b>					
Qty - Type	1 — Backward Curve				
Drive Type	Direct				
Blower size [in. (mm)]	17.7 (450)				
Nominal Motor HP	3.619				3.7
<b>ENERGYX FILTERS</b>					
Type	2-in. Pleated, 30% Efficiency				
Outside Air (Qty) - Size (in.)	(2) 16 x 16 x 2				(2) 20 x 24 x 2
Exhaust Air (Qty) - Size (in.)	(2) 16 x 16 x 2				(2) 20 x 24 x 2
Type	Aluminum Water Filter				
Water Entrapment (Qty) – Size (in.)	(1) 35.75 x 17.5 x 1				(1) 48.25 x 17.15 x 1
<b>EVAPORATOR FAN MOTOR</b>					
<b>STANDARD STATIC 3 PHASE</b>					
Motor Quantity/Drive Type	1 / Belt	1 / Belt	1 / Belt	1 / Belt	1 / Belt
Max BHP	1.7	1.7	2.4	2.4	2.9
RPM Range	518-733	518-733	591-838	591-838	591-838
Motor Frame Size	56	56	56	56	56Y
Fan Quantity/Type	1 / Centrifugal	1 / Centrifugal	1 / Centrifugal	1 / Centrifugal	1 / Centrifugal
Fan Diameter (in.)	15 x 15	15 x 15	15 x 15	15 x 15	18 x 18

See legend on page 15.

## 48HC 7.5 TO 12.5 TON PHYSICAL DATA (cont)

48HC UNIT	48HC**08	48HC**09	48HC**11	48HC**12	48HC**14
<b>EVAPORATOR FAN MOTOR (CONT)</b>					
<b>MEDIUM STATIC 3 PHASE</b>					
Motor Quantity/Drive Type	1 / Belt	1 / Belt	1 / Belt	1 / Belt	1 / Belt
Max BHP	2.4	2.4	3.7	3.7	3.7
RPM Range	690-936	690-936	838-1084	838-1084	609-778
Motor Frame Size	56	56	56HZ	56HZ	56HZ
Fan Quantity/Type	1 / Centrifugal	1 / Centrifugal	1 / Centrifugal	1 / Centrifugal	1 / Centrifugal
Fan Diameter (in.)	15 x 15	15 x 15	15 x 15	15 x 15	18 x 18
<b>HIGH STATIC 3 PHASE†</b>					
Motor Quantity/Drive Type	1 / Belt			—	
Max BHP	3.7	4.9		—	
RPM Range	838-1084	1022-1240		—	
Motor Frame Size	56	145TY		—	
Fan Quantity/Type	1 / Centrifugal	1 / Centrifugal		—	
Fan Diameter (in.)	15 x 15	15 x 15		—	
<b>HIGH STATIC – HIGH EFFICIENCY 3 PHASE</b>					
Motor Quantity/Drive Type	—			1 / Belt	
Max BHP	—			6.5 / 6.9 / 7.0 / 8.3	
RPM Range	—			776-955	
Motor Frame Size	—			S184T	
Fan Quantity/Type	—			1/Centrifugal	
Fan Diameter (in.)	—			18 x 18	
<b>CONDENSER COIL</b>					
Material (Tube/Fin)	Cu / Al				
Coil Type	<sup>3</sup> / <sub>8</sub> in. RTPF				
Rows/FPI	2 / 17	3 / 17		2 / 17	
Total Face Area (ft <sup>2</sup> )	25.1	25.1		2 at 23.1	
<b>CONDENSER FAN/MOTOR</b>					
Quantity/Motor Drive Type	2 / direct	1 / direct ECM		1 / direct	3 / direct
Motor HP/RPM	<sup>1</sup> / <sub>4</sub> / 1100	1 / 1050		1 / 1175	<sup>3</sup> / <sub>4</sub> / 1100
Fan Diameter	22	30		30	22
<b>FILTERS</b>					
RA Filter # / Size (in.)	4 / 20 x 20 x 2				6 / 18 x 24 x 2
OA Inlet Screen # / Size (in.)	1 / 20 x 24 x 1				V - 2 / 24 x 27 x 1 H - 1 / 30 x 39 x 1
<b>GAS CONNECTION</b>					
Number of Gas Valves	1				
Natural Gas Supply Line Pressure (in. wg)/(psig)	4-13 / 0.18-0.47				5-13 / 0.18-0.47
Propane Supply Line Pressure (in. wg)/(psig)	11-13 / 0.40-0.46				
<b>HEAT ANTICIPATOR SETTING (AMPS)</b>					
First Stage	0.14				
Second Stage	0.14				

See legend on page 15.



### 48HC 7.5 TO 12.5 TON PHYSICAL DATA (cont)

48HC UNIT	48HC**08	48HC**09	48HC**11	48HC**12	48HC**14
<b>NATURAL GAS HEAT</b>					
<b>LOW</b>					
Number of Stages / Number of Burners (total)	2 / 3		2 / 4		2 / 5
Connection Size	1/2 in. NPT		3/4 in. NPT		3/4 in. NPT
Rollout Switch Opens / Closes (F)	195 / 115		195 / 115		225 / 145
Temperature Rise Range (F)	20 - 50		20 - 50		20 - 50
<b>MEDIUM</b>					
Number of Stages / Number of Burners (total)	2 / 4		2 / 5		2 / 6
Connection Size	3/4 in. NPT		3/4 in. NPT		3/4 in. NPT
Rollout Switch Opens / Closes (F)	195 / 115		195 / 115		225 / 145
Temperature Rise Range (F)	35 - 65		35 - 65		20 - 55
<b>HIGH</b>					
Number of Stages / Number of Burners (total)	2 / 5		2 / 5		2 / 8
Connection Size	3/4 in. NPT		3/4 in. NPT		3/4 in. NPT
Rollout Switch Opens / Closes (F)	195 / 115		195 / 115		225 / 145
Temperature Rise Range (F)	45 - 75		35 - 70		25 - 60
<b>LIQUID PROPANE HEAT</b>					
<b>LOW</b>					
Number of Stages / Number of Burners (total)	2 / 3		2 / 4		2 / 5
Connection Size	1/2 in. NPT		3/4 in. NPT		3/4 in. NPT
Rollout Switch Opens / Closes (F)	195/115		195/115		195/115
Temperature Rise Range (F)	20 - 50		25 - 65		20 - 60
<b>MEDIUM</b>					
Number of Stages / Number of Burners (total)	2 / 4		2 / 5		2 / 6
Connection Size	3/4 in. NPT		3/4 in. NPT		3/4 in. NPT
Rollout Switch Opens / Closes (F)	195/115		195/115		225/145
Temperature Rise Range (F)	35 - 65	30 - 65	30 - 65		20 - 55
<b>HIGH</b>					
Number of Stages / Number of Burners (total)			2 / 5		2/8
Connection Size			3/4 in. NPT		3/4 in. NPT
Rollout Switch Opens / Closes (F)			195/115		225/145
Temperature Rise Range (F)	45 - 75	40 - 75	35 - 70		25 - 60

**LEGEND**

- BHP** — Brake Horsepower
- EAT** — Entering Air Temperature
- ERV** — Energy Recovery Ventilator
- FPI** — Fins Per Inch
- OA** — Outdoor Air
- RA** — Return Air

- \* Base unit operating weight does not include weight of options.
- † Humidi-MiZer® models only.

# Options and accessories



ITEM	OPTION*	ACCESSORY†
EnergyX Energy Recovery <sup>1</sup>	X	
EnergyX with Economizer <sup>1</sup>	X	
EnergyX with Frost Protection <sup>1</sup>	X	
EnergyX with Frost Protection and Economizer <sup>1</sup>	X	
Filter Maintenance Sensor		X
Motor Status Sensor		X
Thru-the-Base Electrical or Gas-Line Connections	X	
Hinged Access Panels	X	
Supply Duct Cover (Size 14 Only)		X
Cu/Cu (Indoor) Coils <sup>1</sup>	X	
Premium, E-coated Outdoor Coils <sup>1</sup>	X	
Pre-coated (outdoor and indoor) Coils <sup>1</sup>	X	
Humidi-MiZer® Adaptive Dehumidification System <sup>1</sup>	X	
Foil faced insulation throughout entire cabinet	X	
PremierLink™ DDC communicating controller	X	X
ComfortLink Controller	X	
RTU Open Multi-Protocol Controller	X	
Condenser Coil Louvered Hail Guard <sup>1</sup>	X	X
Thermostats, Temperature Sensors, and Subbase		X
Smoke Detector (Supply and/or Return Air)	X	
Horn/Strobe Annunciator <sup>10</sup>		X
Timeguard II compressor delay control circuit		X
Phase Monitor		X
Condensate Overflow switch	X	X
EconoMiSer® IV for electro-mechanical controls — Non FDD (Standard air leak damper models) <sup>1,8</sup>	X	X
EconoMiSer 2 for DDC controls (Standard and Ultra Low Leak air damper models) <sup>9, 10</sup>	X	X
Motorized 2 position outdoor-air damper	X	X
Manual outdoor-air damper (25% and 50%)	X	X
Barometric relief <sup>2</sup>	X	X
Power exhaust (prop design)		X
EconoMiSer X for electro-mechanical controls, complies with FDD. (Standard and Ultra Low Leak air damper models)	X	X
Single Enthalpy Sensors <sup>3</sup>	X	X
Differential Enthalpy Sensors <sup>3</sup>		X

ITEM	OPTION*	ACCESSORY†
Single Dry Bulb Temperature Sensor <sup>3</sup>	X	X
Differential Dry Bulb Temperature Sensor <sup>3</sup>		X
Wall or Duct Mounted CO <sub>2</sub> Temperature Sensor		X
Unit Mounted CO <sub>2</sub> Sensor	X	X
Propane Conversion Kit		X
Stainless Steel Heat Exchanger	X	
High Altitude Conversion Kit		X
Flue Shield (04-12 Models Only)		X
Flue Discharge Deflector		X
Multiple Motor and Drive Packages	X	
Staged Air Volume (SAV) System with VFD Controller (2-Stage Cooling Models Only)	X	
Display Kit or SAV System with VFD		X
Winter Start Kit <sup>4</sup>		X
Motormaster Head Pressure Controller to -2°F <sup>4</sup>	X	X
Powered Convenience Outlet <sup>1,5</sup>	X	
Unpowered Convenience Outlet (15 amp factory-installed; 20 amp field-installed)	X	X
Non-Fused Disconnect <sup>7</sup>	X	
HACR Circuit Breaker <sup>6</sup>	X	
Roof Curb 14-in. (356 mm)		X
Roof Curb 24-in. (610 mm)		X
Horizontal Curb Adapter (Vertical to Horizontal Airflow)		X

\* Factory-installed option.

† Field-installed accessory.

NOTES:

- Not available as factory-installed option on single-phase (208-230/1/60) models. Use field-installed accessory where available.
- Included with economizer.
- Sensors used to optimize economizer performance.
- See application data for assistance.
- Powered convenience outlet is not available on single-phase models and size 11 models with 460 and 575 voltage.
- HACR circuit breaker cannot be used when rooftop MOCB electrical rating exceeds:  
Size 04-12 — 208-230/1/60 and 208-230/3/60 = 100 amps, 460/3/60 = 90 amps, 575/3/60 = 70 amps.  
Size 14 — 208-230/3/60 = 200 amps, 460/3/60 = 90 amps, 575/3/60 = 80 amps.  
HACR circuit breaker on 575 volt can only be used on Wye power supply. Delta power supply is prohibited. Carrier RTUBuilder automatically selects the amp limitations.
- Non-fused disconnect switch (04-12 sizes) cannot be used when unit FLA electrical rating exceeds 80 amps (all voltages). Non-fused disconnect switch (14 size) cannot be used when unit FLA electrical rating exceeds 100 amps (all voltages). Carrier RTUBuilder automatically selects the amp limitations.
- FDD - (Fault Detection and Diagnostic) per California Title 24-2015 section 120.2.
- Models with ComfortLink and RTU Open DDC controllers comply with ASHRAE 90.1-2016 and California Title 24-2015 Fault Detection and Diagnostic (FDD). PremierLink is non FDD.
- Requires a field-supplied 24V transformer for each application. See price pages for details.
- OSHPD not available on units with factory installed Humidi-MiZer, HACR breaker, low ambient controls, hailguards, or EnergyX system.



## Factory-Installed Options

**Optional EnergyX® system (3-phase models only)** — The EnergyX energy recovery ventilator (ERV) module is controlled by a digital controller located inside the EnergyX chassis. It communicates with the WeatherMaster® *ComfortLink* controller via a UPC translator module which connects to the WeatherMaster rooftop unit's *ComfortLink* controller via a LEN cable. All controller settings and configuration are input via the *ComfortLink* scrolling marquee display.

All control points, including outdoor airflow, exhaust airflow and CO<sub>2</sub> setpoints are configured via the *ComfortLink* scrolling marquee interface.

NOTE: CO<sub>2</sub> sensor requires a factory installed economizer.

The EnergyX energy recovery unit pre-conditions the outdoor air before it mixes with the return air and enters the rooftop unit evaporator coil. As a result, the EnergyX operation is mostly independent of the rooftop unit operation except to allow the space conditioning needs to be met without RTU compressor operation or RTU heat operation for a significantly wider range of ambient temperatures (than a unit without an energy recovery module). This is achieved either by the pre-conditioning of the EnergyX wheel or the economizer (if equipped). The EnergyX system will pre-condition the outside air in the cooling and heating modes of operation.

Energy recovery devices such as the EnergyX® system typically result in substantial energy savings over other outdoor air devices. Specifically, the EnergyX system adds sensible and latent capacity as well as additional stages of cooling and heating operation to the rooftop unit. Due to the EnergyX system's significantly lower input watts than the corresponding RTU compressor(s), proper control strategies for this device maximize its operation to reduce the run time of the RTU compressor(s). This results in a much higher system efficiency than can typically be achieved by using a rooftop unit of the same total capacity.

The EnergyX system with its modulating airflow capability allows a designer to increase the amount of outside air significantly more than normal with the following benefits:

- Reduced rooftop unit sizing - The more air that passes through the energy recovery device reduces the load (and potential unit size) on the rooftop unit's compressors and heating system.
- Higher system cooling and heating efficiencies — Since the EnergyX wheel uses the power of 'rotary enthalpy transfer' as opposed to mechanical compression conditioning of the ventilation air resulting in a much higher operating efficiency (RER) of the energy recovery unit and system Combined Efficiency Factor (CEF). The higher the airflow through the EnergyX wheel, the higher the system efficiency (CEF) value. Since the EnergyX system also conditions ventilation air in the heating mode, the necessary amount and/or operation of the rooftop unit heat system is reduced.
- Better part load conditioning — As the EnergyX system is able to modulate its airflow, the ability to match the changing zone part-load capacity (in cooling and in heating) is greatly increased.

- Higher air change rates — Larger amounts of ventilation air allows the zone air to be flushed out more often. This can contribute significantly to reduced sickness and more productive operating environments.

All ventilated spaces are good candidates for energy recovery systems. The applications that benefit most are those that require a large amount of outside air for a space that has a low internal load. This is true because most outside air loads are latent which requires a larger rooftop unit to accommodate both internal and ventilation loads. Advantages of the ERV unit include the ability to reduce the size of the rooftop unit, provide better humidity levels and provide a stable, tempered space.

Examples of ERV applications are classrooms, churches, conference rooms, game rooms, auditoriums, movie theaters, day care centers, nursing homes, funeral homes, dormitories, and clinics. Retrofits of existing systems to handle outside air without modifying the rooftop unit are excellent applications. Other examples are bars, restaurants, casino/game rooms, barber/beauty shops, bingo halls, locker rooms, recreational facilities and health clubs. Animal shelters such as veterinary clinics and kennels have been very successful implementations. Retail spaces and manufacturing facilities are also good applications.

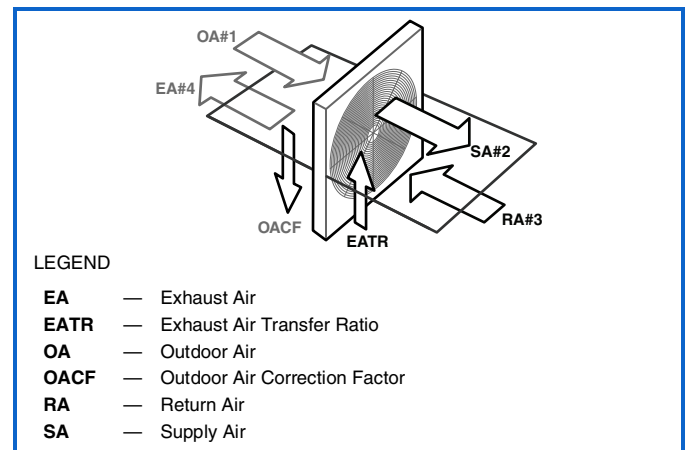

If the outside air requirement is greater than 10% of a rooftop unit's supply air rating the EnergyX unit should be considered to enhance the comfort of the occupants and reduce the tonnage of the rooftop unit. Carrier's Packaged RTU Builder selection software program offers a quick, simple look at the advantages and payback of the EnergyX system.

**EnergyX® with economizer (3-phase models only)** — Allows true modulating economizer capability when OA is suitable for free cooling.

- operates as a true wheel bypass
- uses stop/jog operation for wheel required when using CO<sub>2</sub> sensor for DCV operation
- economizer integrated into EnergyX unit

**EnergyX® with frost protection (3-phase models only)** — Senses pressure differential across the energy recovery cassette. Uses exhaust air to defrost the wheel when necessary.

**Optional Humidi-MiZer® adaptive dehumidification system** — Carrier's Humidi-MiZer adaptive dehumidification system is an all-inclusive factory-installed option that can be ordered with any WeatherMaster® 48HC04-14 rooftop unit, with the exception of single phase voltage (208-230/1/60) units.

This system expands the envelope of operation of Carrier's WeatherMaster rooftop products to provide unprecedented flexibility to meet year round comfort conditions.

The Humidi-MiZer adaptive dehumidification system has a unique dual operational mode setting. The Humidi-MiZer system provides greater dehumidification of the occupied space by two modes of dehumidification operations in addition to its normal design cooling mode.

The WeatherMaster® 48HC04-14 rooftop coupled with the Humidi-MiZer system is capable of operating in normal design cooling mode, sub-cooling mode, and hot gas re-heat mode. Normal design cooling mode is when the unit will operate under its normal sequence of operation by cycling compressors to maintain comfort conditions.

Sub-cooling mode will operate to satisfy part load type conditions when the space requires combined sensible and a higher proportion of latent load control. Hot Gas Reheat mode will operate when outdoor temperatures diminish and the need for latent capacity is required for sole humidity control. Hot Gas Reheat mode will provide neutral air for maximum dehumidification operation.

**Thru-the-base connections** — Thru-the-base connections, available as a factory option, are necessary to ensure proper connection and seal when routing wire and piping through the rooftop's basepan and curb. These couplings eliminate roof penetration and should be considered for gas lines, main power lines, as well as control power.

**Hinged access panels** — Allows access to unit's major components with specifically designed hinged access panels. Panels are filter, control box, indoor fan motor and ERV access.

**Cu/Cu (indoor) coils** — Copper fins and copper tubes are mechanically bonded to copper tubes and copper tube sheets. A polymer strip prevents coil assembly from contacting the sheet metal coil pan to minimize potential for galvanic corrosion between coil and pan.

**E-coated (outdoor and indoor) coils** — A flexible epoxy polymer coating uniformly applied to all coil surface areas without material bridging between fins. Coating process shall ensure complete coil encapsulation of tubes, fins and headers.

**Pre-coated outdoor coils** — A durable epoxy-phenolic coating to provide protection in mildly corrosive coastal environments. The coating minimizes galvanic action between dissimilar metals. Coating is applied to the aluminum fin stock prior to the fin stamping process to create an inert barrier between the aluminum fin and copper tube.

**Condenser coil hail guard** — Sleek, louvered panels protect the condenser coil from hail damage, foreign objects, and incidental contact.

**Smoke detector (supply and/or return air)** — Trust the experts. Smoke detectors make your application safer and your job easier. Carrier smoke detectors immediately shut down the rooftop unit when smoke is detected. They are available, installed by the factory, for supply air, return air, or both.

**Single enthalpy sensor** — Prevents the wheel from rotating if the outside air conditions are acceptable for free cooling. Both exhaust and supply blowers will remain on.

**Unit mounted CO<sub>2</sub> sensor** — Improves productivity and saves money by working with the economizer to intake only the correct amount of outside air for ventilation. As occupants fill your building, the CO<sub>2</sub> sensor detects their presence through increasing CO<sub>2</sub> levels, and opens the economizer appropriately. When the occupants leave, the CO<sub>2</sub> levels decrease, and the sensor appropriately closes the economizer. This intelligent control of the ventilation air, called demand controlled ventilation (DCV) reduces the overall load on the rooftop, saving money.

**Stainless steel heat exchanger** — The stainless steel heat exchanger option provides the tubular heat exchanger be made out of a minimum 20 gauge type 409 stainless steel for applications where the mixed air to the heat exchanger is expected to drop below 45°F (7°C). Stainless steel may be specified on applications where the presence of airborne contaminants require its use (applications such as paper mills) or in area with very high outdoor humidity that may result in severe condensation in the heat exchanger during cooling operation.

**Convenience outlet (powered or un-powered)** — Reduce service and/or installation costs by including a convenience outlet in your specification. Carrier will install this service feature at our factory. Provides a convenient, 15 amp, 115v GFCI receptacle with "Wet in Use" cover. The "powered" option allows the installer to power the outlet from the line side of the disconnect or load side as required by code. The "unpowered" option is to be powered from a separate 115/120v power source.

The unpowered convenience outlet is available as a 15 amp factory-installed option or a 20 amp field-installed accessory.

**Non-fused disconnect** — This OSHA-compliant, factory-installed, safety switch allows a service technician to locally secure power to the rooftop.

**HACR circuit breaker** — These manual reset devices provide overload and short circuit protection for the unit. Factory wired and mounted with the units with access cover to help provide environment protection.

On 575V applications, HACR breaker can only be used with WYE power distribution systems. Use on Delta power distribution systems is prohibited.

**Foil-faced insulated cabinet** — Cabinet is fully insulated with non-fibrous, foil-faced cleanable insulation that is secured and encapsulated in unit design.

**PremierLink™ DDC controller** — This CCN (Carrier Comfort Network®) regulates your rooftop's performance to tighter tolerances and expanded limits, as well as facilitates zoning systems and digital accessories. It also unites your Carrier HVAC equipment together on one, coherent CCN network. The PremierLink controller can be factory-installed, or easily field-installed. The controller is not available when SAV (Staged Air Volume) 2-speed indoor fan or EnergyX is installed.

**ComfortLink controller** — Models with the optional Carrier *ComfortLink* controls allow added unit diagnostics and operation setup capabilities. *ComfortLink* comes standard with units equipped with EnergyX.

The *ComfortLink* control is your link to a world of simple and easy to use rooftop units that offer outstanding performance and value. It optimizes the performance of the refrigeration circuits as conditions change, resulting in the following features:

- Better control of temperature and humidity
- Superior reliability
- Automatic redundancy
- Low ambient cooling operation to 0°F (–18°C)
- More accurate diagnostics, at unit or remote

The *ComfortLink* scrolling marquee is very easy to use. The messages are displayed in easy to understand English, no decoding is required. A scrolling readout provides detailed explanations of control information. Only four, large, easy-to-use buttons are required to maneuver through the entire menu. The readout is designed to be visible even in the brightest sunlight. A hand held Navigator™ accessory or wall-mounted System Pilot™ accessory can be used for added service flexibility.

The *ComfortLink* control provides unparalleled service diagnostic information. Temperature and pressure can be read directly from the display with no need for separate gauges. Other data, such as compressor cycles, unit run time hours, current alarms, can also be accessed. A history of alarms is also available for viewing.

The service run test can be very helpful when troubleshooting. The user can run test major components to determine the root cause of a problem. The unit can be run-tested before an installation is complete to ensure satisfactory start-up. To ensure reliability, the *ComfortLink* control prevents reverse compressor rotation. No laptop computers are required for start-up.

Time schedules are built in and the Scrolling Marquee display provides easy access to setpoints. The *ComfortLink* control accepts input from a CO<sub>2</sub> sensor and a smoke detector. Both are available as factory-installed options or as field-installed accessories.

**RTU Open, multi-protocol controller** — Connect the rooftop to an existing BAS (building automation system) without needing complicated translators or adapter modules using the RTU Open controller. The RTU Open controller speaks the 4 most common building automation

system languages (BACnet, Modbus, Johnson Controls N2, and LonWorks). Use this controller when you have an existing BAS. Besides the 4 protocols, it also communicates with a Carrier Open system (i-Vu® and VVT®). Not compatible when EnergyX is installed.

**Time Guard II control circuit** — This accessory protects your compressor by preventing short-cycling in the event of some other failure, prevents the compressor from restarting for 30 seconds after stopping. Not required with PremierLink™ controller, RTU Open controller, *ComfortLink* controller, or authorized commercial thermostats.

**Condensate overflow switch** — This sensor and related controller monitors the condensate level in the drain pan and shuts down compression operation when overflow conditions occur. It includes:

- Indicator light — solid red (more than 10 seconds on water contact — compressors disabled), blinking red (sensor disconnected)
- 10-second delay to break — eliminates nuisance trips from splashing or waves in pan (sensor needs 10 seconds of constant water contact before tripping)
- Disables the compressor(s) operation when condensate plug is detected, but still allows fans to run for Economizer.

**Power exhaust with barometric relief** — Superior internal building pressure control. This field-installed accessory may eliminate the need for costly, external pressure control fans.

**Low ambient controller** — The low ambient controller is a head pressure controller kit that is designed to maintain the unit's condenser head pressure during periods of low ambient cooling operation. This device should be used as an alternative to economizer free cooling when economizer usage is either not appropriate or desired. The low ambient controller will either cycle the outdoor fan motors or operate them at reduced speed to maintain the unit operation, depending on the model. This controller allows cooling operation down to –20°F (–18°C) ambient conditions. (Not available on size 11 models as standard unit cooling operation down to 0°F /–18°C.)

**California OSHPD Seismic Certification Label** — Units meet the seismic requirements of the International Code Council Evaluation Service (ICC-ES) document AC156 (Acceptance Criteria for Seismic Qualification by Shake-Table Testing of Nonstructural Components and Systems) and per International Building Code (IBC 2009) at an SDS (g) value of 2.00 z/h=1.0, Ip=1.5 and certified by independent structural engineers. A certification label is applied to the unit that meets the CA OSHPD Special Seismic Certification pre-approval labeling requirements on the external chassis of the unit.

### Field-installed accessories

**Filter maintenance indicator** — When the optional factory-installed filter maintenance indicator is used, a factory-installed differential pressure switch measures pressure drop across the outside air filter and activates a field-supplied dry contact indicator when the pressure differential exceeds the adjustable switch setpoint.

**Condenser coil hail guard** — Sleek, louvered panels protect the condenser coil from hail damage, foreign objects, and incidental contact. This can be purchased as a factory-installed option or as a field-installed accessory.

**Differential enthalpy sensor** — The differential enthalpy sensor is comprised of an outdoor and return air enthalpy sensors to provide differential

**Wall or duct mounted CO<sub>2</sub> sensor** — The IAQ sensor shall be available in duct or wall mount. The sensor provides demand ventilation indoor air quality (IAQ) control.

**Propane conversion kit** — Convert your gas heat rooftop from standard natural gas operation to Propane using this field-installed kit.

**High altitude conversion kit** — High altitudes have less oxygen, which affects the fuel/air mixture in heat exchangers. In order to maintain a proper fuel/air mixture, heat exchangers operating in altitudes above 2000 ft (610 m) require different orifices. To select the correct burner orifices or determine the heat capacity for a high altitude application, use either the selection software, or the unit's service manual. High altitudes have less oxygen, which means heat exchangers need less fuel. The new gas orifices in this field-installed kit make the necessary adjustment for high altitude applications. They restore the optimal fuel to air mixture and maintain healthy combustion on altitudes above 2000 ft (610 m).

NOTE: Typical natural gas heating value ranges from 975 to 1050 Btu/ft<sup>3</sup> at sea level nationally. The heating value goes down approximately 1.7% per every thousand feet elevation. Standard factory orifices can typically be used up to 2000 ft (610 m) elevation without any operational issues.

**Flue discharge deflector** — The flue discharge deflector is a useful accessory when flue gas recirculation is a concern. By venting the flue discharge upwards, the deflector minimizes the chance for a neighboring unit to intake the flue exhaust.

**Display kit for SAV™ system with VFD** — Allows the ability to access the VFD controller programs to provide special setup capabilities and diagnostics. The kit contains a display module, mounting bracket, and communication cable. The display kit can be permanently installed in the unit or used on any SAV system VFD controller as needed.

**Winter start kit** — The winter start kit by Carrier extends the low ambient limit of your rooftop to 25°F (-4°C). The kit bypasses the low pressure switch, preventing nuisance tripping of the low pressure switch. Other low ambient precautions may still be prudent.

**Motormaster® head pressure controller** — The Motormaster motor controller is a low ambient, head pressure controller kit that is designed to maintain the unit's condenser head pressure during periods of low ambient cooling operation. This device should be used as an alternative to economizer free cooling not when economizer usage is either not appropriate or desired. The Motormaster controller will either cycle the outdoor-fan motors or operate them at reduced speed to maintain the unit operation, depending on the model. This controller allows cooling operation down to -20°F (-18°C) ambient conditions.

**Roof curb (14-in./356 mm or 24-in./610 mm)** — Full perimeter roof curb with exhaust capability provides separate air streams for energy recovery from the exhaust air without supply air contamination.

**Horizontal roof curb adapter (vertical to horizontal airflow) — horizontal roof curb adapters** — Used when horizontal supply and/or return is desired.

**Filter status indicator accessory** — Monitors static pressure across supply and exhaust filters and provides indication when filters become clogged.

**Motorized exhaust damper accessory** — Replaces the standard barometric exhaust damper blades with motorized (open/shut) damper (not compatible with EnergyX).



### OPTIONS AND ACCESSORY WEIGHTS

OPTION / ACCESSORY NAME	48HC UNIT WEIGHT																	
	04		05		06		07		08		09		11		12		14	
	lb	kg	lb	kg	lb	kg	lb	kg	lb	kg	lb	kg	lb	kg	lb	kg	lb	kg
EnergyX® System	464	210	650	295	650	295	670	304	869	394	869	394	869	394	869	394	1155	524
Humidi-MiZer® System*	50	23	55	25	55	25	80	36	80	36	80	36	85	39	85	39	90	41
Power Exhaust - vertical	50	23	50	23	50	23	75	34	75	34	75	34	75	34	75	34	85	39
Power Exhaust - horizontal	30	14	30	14	30	14	30	14	30	14	30	14	30	14	30	14	75	34
EconoMiSer® (X, IV or 2)	50	23	50	23	50	23	50	23	74	34	74	34	74	34	74	34	103	47
Two-Position Damper	39	18	39	18	39	18	58	26	58	26	58	26	58	26	58	26	65	29
Manual Dampers	12	5	12	5	12	5	18	8	18	8	18	8	18	8	18	8	25	11
Medium Gas Heat	12	5	9	4	9	4	15	7	15	7	15	7	18	8	18	8	18	8
High Gas Heat	—	—	17	8	17	8	29	13	29	13	29	13	35	16	35	16	42	19
Hail Guard (louvered)	16	7	16	7	16	7	34	15	34	15	34	15	34	15	34	15	45	20
Cu/Cu Condenser Coil	35	16	35	16	35	16	95	43	95	43	95	43	170	77	170	77	190	86
Cu/Cu Cond. and Evap. Coils	60	27	60	27	90	41	140	64	140	64	195	88	270	122	270	122	280	127
Roof Curb (14-in. curb)	115	52	115	52	115	52	143	65	143	65	143	65	143	65	143	65	180	82
Roof Curb (24-in. curb)	197	89	197	89	197	89	245	111	245	111	245	111	245	111	245	111	255	116
CO <sub>2</sub> sensor	5	2	5	2	5	2	5	2	5	2	5	2	5	2	5	2	5	2
Flue Discharge Deflector	7	3	7	3	7	3	7	3	7	3	7	3	7	3	7	3	—	—
Optional Indoor Motor/Drive	10	5	10	5	10	5	15	7	15	7	15	7	15	7	15	7	45	20
Motormaster® Controller	35	16	35	16	35	16	35	16	35	16	35	16	35	16	35	16	40	18
Low Ambient Controller	5	2	5	2	5	2	5	2	5	2	5	2	8	3	10	5	30	14
Return Smoke Detector	5	2	5	2	5	2	5	2	5	2	5	2	5	2	5	2	5	2
Supply Smoke Detector	5	2	5	2	5	2	5	2	5	2	5	2	5	2	5	2	5	2
Fan/Filter Status Switch	2	1	2	1	2	1	2	1	2	1	2	1	2	1	2	1	2	1
Non-Fused Disconnect	15	7	15	7	15	7	15	7	15	7	15	7	15	7	15	7	15	7
HACR Circuit Breaker	15	7	15	7	15	7	15	7	15	7	15	7	15	7	15	7	15	7
Powered Convenience Outlet	35	16	35	16	35	16	35	16	35	16	35	16	35	16	35	16	35	16
Non-Powered Convenience Outlet	5	2	5	2	5	2	5	2	5	2	5	2	5	2	5	2	5	2
Enthalpy Sensor	2	1	2	1	2	1	2	1	2	1	2	1	2	1	2	1	2	1
Differential Enthalpy Sensor	3	1	3	1	3	1	3	1	3	1	3	1	3	1	3	1	3	1
SAV™ System with VFD	—	—	—	—	—	—	20	9	20	9	20	9	20	9	20	9	20	9

**LEGEND**

— Not Available

\* For Humidi-MiZer® system and Motormaster® controller.

NOTE: Where multiple variations are available, the heaviest combination is listed.

## 48HC\*\*04-06 BASE UNIT DIMENSIONS (UNITS BUILT ON AND AFTER 4/15/2019)

**NOTES:**

- DIMENSIONS ARE IN INCHES. DIMENSIONS IN "L", "J" ARE IN MILLIMETERS.
- CENTER OF GRAVITY
- DIRECTION OF AIR FLOW
- ALL VIEW DRAWN USING 3RD ANGLE

UNIT	J	K
48HC**04	33-3/8 [847]	18-2/8 [472]
48HC**05	41-5/8 [1051]	17-7/8 [454]
48HC**06	41-3/8 [1051]	14-7/8 [377]

**DRAWING REPRESENTS PRODUCT BUILT ON AND AFTER 04/15/2019 (STARTING WITH SERIAL NUMBER 1619...) SEE DETAIL "E" SHT 5**

**CONNECTION SIZES**

LETTER	DESCRIPTION	SIZE
A	1-3/8" DIA. FIELD POWER SUPPLY HOLE	
B	2" DIA. POWER SUPPLY KNOCKOUT	
C	1-3/4" DIA. GAUGE ACCESS PLUG	
D	7/8" DIA. FIELD CONTROL WIRING HOLE	
E	3/4" x 1/4" NPT CONDENSATE DRAIN	
F	1/2" x 1/2" NPT GAS CONNECTION	
G	2-1/2" DIA. POWER SUPPLY KNOCK-OUT	

**TURN THE BASE CHART THESE HOLES REQUIRED FOR USE (SEE IMPROVED 080A00 - 090A00)**

WIRE CONDUIT SIZE	WIRE USE SIZES (MAX.)
1/2"	155 7/8" [22.2]
1/2"	249 7/8" [22.2]
3/4"	POWER 1-1/8" [28.6]
Z*	GAS 1-1/8" [28.6]

\* FOR "THRU-THE-BASEPAN" FACTORY OPTION. FITTINGS FOR ONLY X, Y, & Z ARE PROVIDED. (080A00) PROVIDES 3/4" FPT THRU CURB FLANGE & FITTING.

**TIC CLASSIFICATION**  
U.S. ECCN: NSR

**SHEET**  
1 OF 5

**DATE**  
12/24/18

**SUPERCEDES**  
07/28/16

**REV**  
C

**48HC 04-06 SINGLE ZONE ELECTRICAL COOLING WITH GAS HEAT**

481M502588

**48HC\*\*04-06 BASE UNIT DIMENSIONS (UNITS BUILT ON AND PRIOR TO 4/14/2019)**

DRAWING REPRESENTS PRODUCT BUILT ON AND PRIOR TO 04/14/2019  
SEE DETAIL "B" SHT 5

- NOTES:  
 1. DIMENSIONS ARE IN INCHES. DIMENSIONS IN ( ) ARE IN MILLIMETERS.  
 2. CENTER OF GRAVITY  
 3. DIRECTION OF AIR FLOW  
 4. ALL VIEWS DRAWN USING 3RD ANGLE

UNIT	J	K
48HC*04	33 3/8 [848]	18 5/8 [472]
48HC*05	41 3/8 [1051]	14 7/8 [377]
48HC*06	41 3/8 [1051]	14 7/8 [377]

CONNECTION SIZES	
A	1 3/8" [35] DIA. FIELD POWER SUPPLY HOLE
B	2" [50] DIA. POWER SUPPLY KNOCKOUT
C	1 3/4" [44] DIA. GAUGE ACCESS PLUG
D	7/8" [22] DIA. FIELD CONTROL WIRING HOLE
E	3/4" - 1/4 NPT CONDENSATE DRAIN
F	1/2" - 1/4 NPT GAS CONNECTION
G	2 1/2" - 1/4 DIA. POWER SUPPLY KNOCK-OUT

THRU-THE-BASE CHART THESE HOLES REQUIRED FOR USE CERAMIC/001A01, 003A01	
THREADED CONDUIT SIZE	REQ'D HOLE SIZES (MAX.)
W	1 1/2" - 1 1/8" [38.1]
X	1 1/2" - 2 1/8" [50.8]
Y	3/4" - 1 1/8" [38.1]
Z**	1 1/2" - 1 1/8" [38.1]

FOR "THRU-THE-BASEPAN" FACTORY OPTION, FITTINGS FOR ONLY X, Y, & Z ARE PROVIDED FOR POWER. DEPENDING ON WIRE SIZE SELECT EITHER 3/4" OR 1/2" (001A01) PROVIDES 3/4" FPT THRU CURB FLANGE & FITTING.

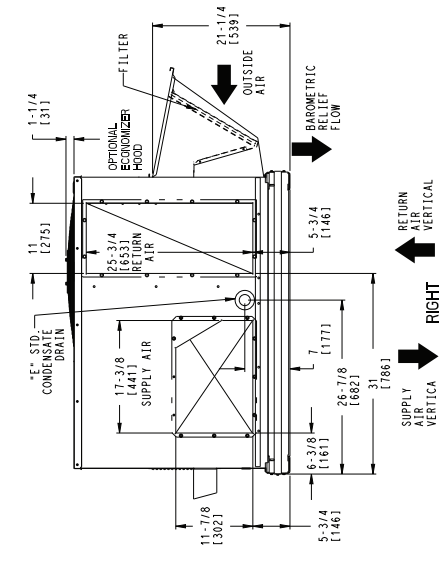
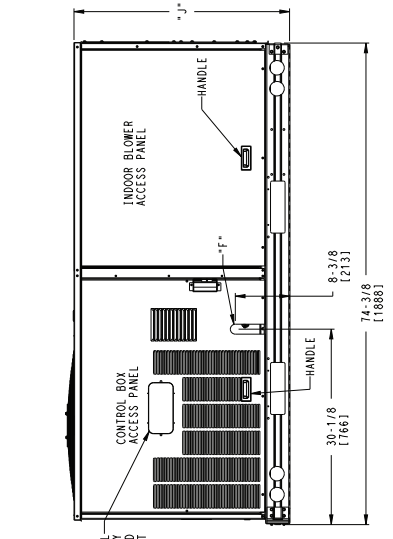
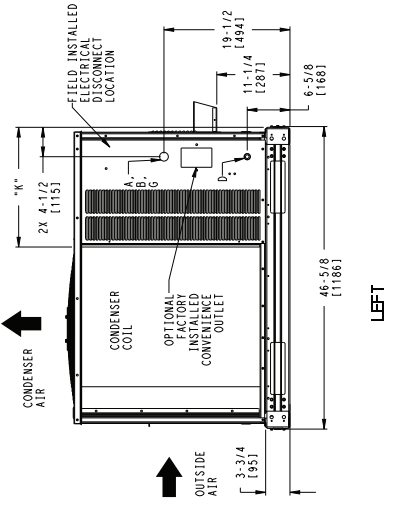
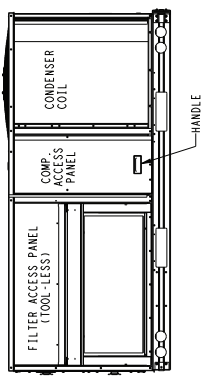
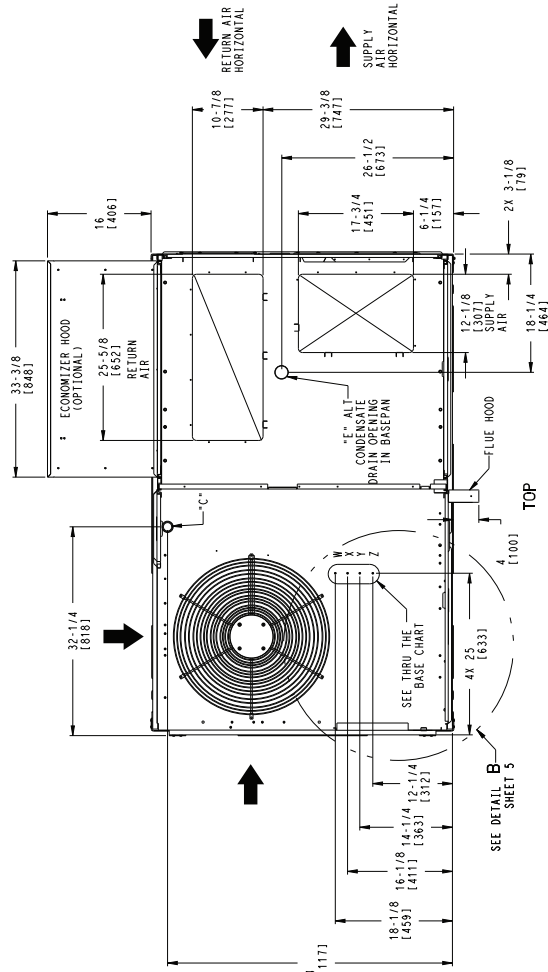

TIC CLASSIFICATION	SHEET	DATE	SUPERSEDES	REV
U.S. ECCN: NSR	2 OF 5	12/24/18	07/28/16	481M502588
48HC 04-06 SINGLE ZONE ELECTRICAL COOLING WITH GAS HEAT				C

## 48HC\*\*04-06 BASE UNIT CORNER WEIGHTS AND CLEARANCES

**Carrier**  
United Technologies

THIS DOCUMENT IS THE PROPERTY OF HVAC CLIMATE CONTROLS. SUBMISSION OF THESE DRAWINGS OR DOCUMENTS DOES NOT CONSTITUTE AN AGREEMENT OR ACCEPTANCE OF LIABILITY WITHOUT WRITTEN CONSENT.

UNIT *	STD. UNIT WEIGHT		CORNER WEIGHT (A)		CORNER WEIGHT (B)		CORNER WEIGHT (C)		CORNER WEIGHT (D)		C. G.			HEIGHT					
	LBS.	KG.	LBS.	KG.	LBS.	KG.	LBS.	KG.	LBS.	KG.	X	Y	Z	HEIGHT	Z				
48HCDA04	505	229	124	56	117	53	128	58	136	62	36	1/8	[918]	24	3/8	[619]	19	[483]	
48HCDA05	590	268	151	69	144	65	144	65	151	69	36	1/4	[921]	23	3/8	[594]	20	1/8	[511]
48HCDA06	600	271	156	71	145	66	144	65	155	70	35	1/8	[911]	23	1/4	[591]	19	1/2	[495]

\* STANDARD UNIT WEIGHTS WITH LOW GAS HEAT AND WITHOUT PACKAGING. FOR OTHER OPTIONS AND ACCESSORIES REFER TO THE PRODUCT DATA CATALOG.

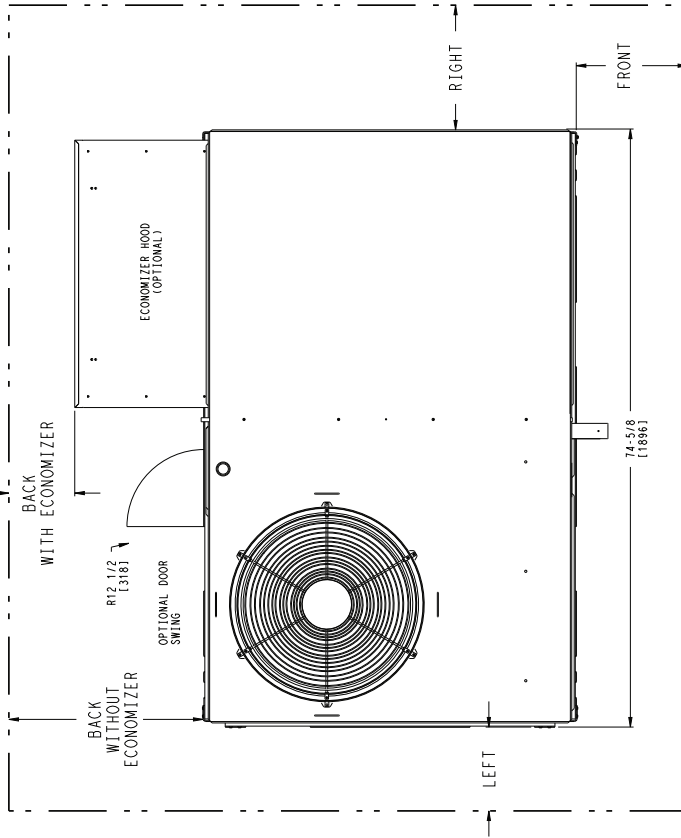

CORNER B

CORNER A

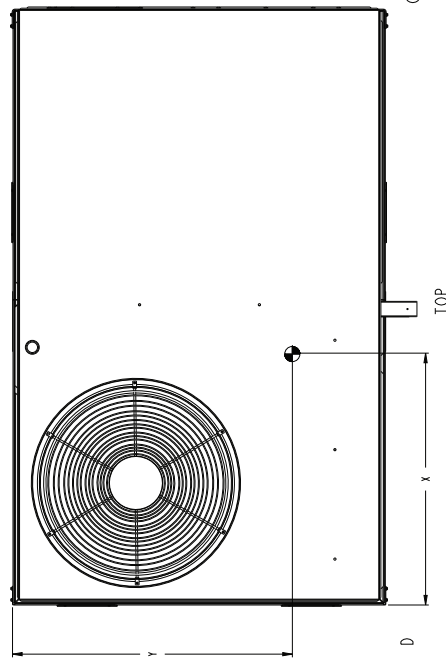

CORNER D

CORNER C

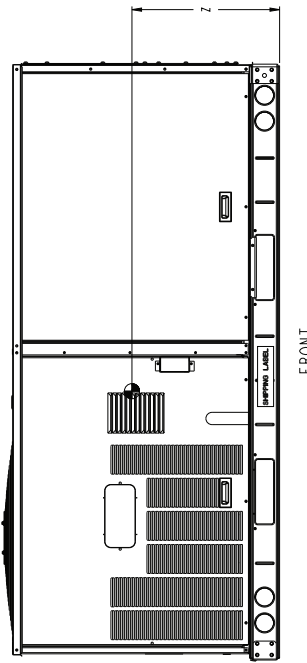

FRONT

**NOTES:**

1. FOR ALL MINIMUM CLEARANCES LOCAL CODES OR JURISDICTIONS MAY PREVAIL.

SURFACE	CLEARANCE		
	SERVICE WITH CONDUCTIVE BARRIER	NONCONDUCTIVE BARRIER	OPERATING CLEARANCE
FRONT	48 [1219mm]	36 [914mm]	18 [457mm]
LEFT	48 [1219mm]	42 [1067mm]	18 [457mm]
BACK	48 [1219mm]	42 [1067mm]	18 [457mm]
BACK W/HOOD	36 [914mm]	36 [914mm]	18 [457mm]
RIGHT	72 [1829mm]	72 [1829mm]	72 [1829mm]
TOP	72 [1829mm]	72 [1829mm]	72 [1829mm]

ITC CLASSIFICATION	SHEET	DATE	REV
U.S. - ECCN: NSR	3 OF 5	12/24/18	C
SUPERCEDES	48HC 04-06 SINGLE ZONE ELECTRICAL COOLING WITH GAS HEAT	07/28/16	48TM502588



# 48HC\*\*04-06 BACK VIEW AND BASERAIL DIMENSIONS

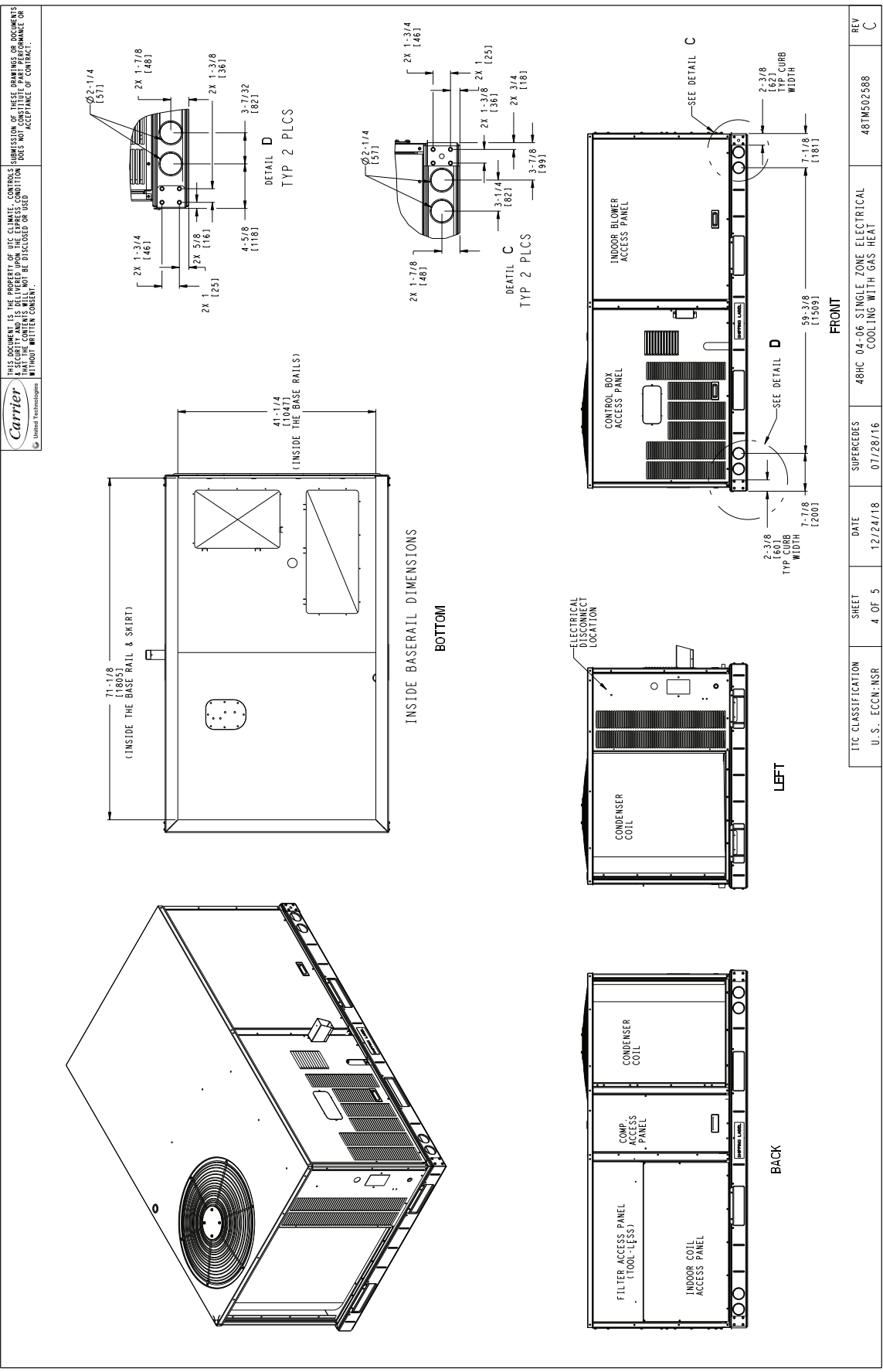

**Carrier**  
© United Technologies

THIS DOCUMENT IS THE PROPERTY OF UTC CLIMATE CONTROLS. SUBMISSION OF THESE DRAWINGS OR DOCUMENTS TO ANY OTHER PARTY WITHOUT THE WRITTEN CONSENT OF UTC CLIMATE CONTROLS DOES NOT CONSTITUTE PART PERFORMANCE OR ACCEPTANCE OF CONTRACT.

TTC CLASSIFICATION	SHEET	DATE	SUPERCEDS	REV
U. S. - ECCN: NSR	4 OF 5	12/24/18	07/28/16	C
48HC 04-06 SINGLE ZONE ELECTRICAL COOLING WITH GAS HEAT				48TMS02588

## 48HC\*\*04-06 THRU-THE-BASE ELECTRICAL CONNECTIONS REQUIRED HOLE SIZE

**Carrier**  
United Technologies

THIS DOCUMENT IS THE PROPERTY OF UTC CLIMATE CONTROLS. SUBMISSION OF THESE DRAWINGS OR DOCUMENTS TO ANY OTHER PARTY WITHOUT THE WRITTEN CONSENT OF UTC CLIMATE CONTROLS WILL BE AT THE SUBMITTER'S RISK. THIS CONDITION DOES NOT CONSTITUTE WARRANTY OF PERFORMANCE OR ACCEPTANCE OF CONTRACT.

THRU-THE-BASE CHART FOR WIRE USE CRBTMPR001001, 003A01			
THREADED CONDUIT SIZE	WIRE USE	REQ'D HOLE SIZES (MAX.)	
W	1/2"	11SV 7/8" [22.2]	
X	1/2"	24V 7/8" [22.2]	
Y	3/4"	POWER 1 1/8" [28.6]	
Z**	003A01 1/2" FPT GAS	1 1/8" [28.6]	
FOR "THRU-THE-BASEPAN" FACTORY OPTION, FITTINGS FOR ONLY X, Y, & Z ARE PROVIDED			
SELECT EITHER 3/4" OR 1/2" FOR POWER, DEPENDING ON WIRE SIZE			
** (001A01) PROVIDES 3/4" FPT THRU CURB FLANGE & FITTING.			

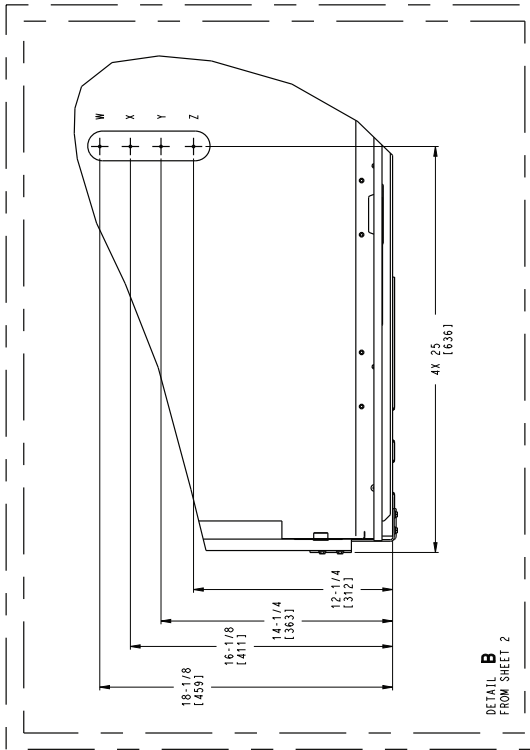

THRU-THE-BASE CHART FOR WIRE USE CRBTMPR008A00, 009A00			
THREADED CONDUIT SIZE	WIRE USE	REQ'D HOLE SIZES (MAX.)	
W	1/2"	11SV 7/8" [22.2]	
X	1/2"	24V 7/8" [22.2]	
Y	3/4"	POWER 1 1/8" [28.6]	
Z*	009A00 1/2" FPT GAS	1 1/8" [28.6]	
FOR "THRU-THE-BASEPAN" FACTORY OPTION, FITTINGS FOR ONLY X, Y, & Z ARE PROVIDED			
* (008A00) PROVIDES 3/4" FPT THRU CURB FLANGE & FITTING.			

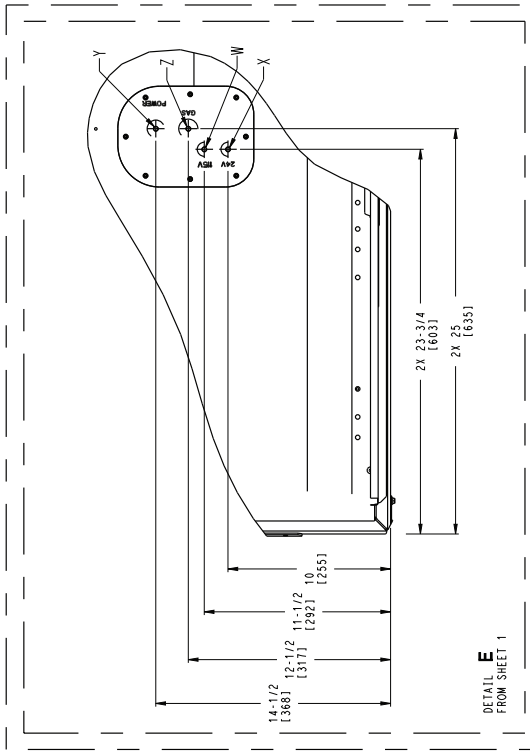

THIS VIEW REPRESENTS PRODUCT BUILT ON AND PRIOR TO 04/14/2019

THIS VIEW REPRESENTS PRODUCT BUILT ON AND AFTER 04/15/2019

U.S. ECCN: NSR	SHEET 5 OF 5	DATE 12/24/18	SUPERCEDES 07/28/16	48HC 04-06 SINGLE ZONE ELECTRICAL COOLING WITH GAS HEAT	REV C
----------------	--------------	---------------	---------------------	---	-------

# 48HC\*\*07-09 BASE UNIT DIMENSIONS

- NOTES:
1. DIMENSIONS ARE IN INCHES. DIMENSIONS IN [ ] ARE IN MILLIMETERS.
  2. CENTER OF GRAVITY
  3. DIRECTION OF AIR FLOW

UNIT	J	K	H
48HC-A-007	41-1/4 [1048]	33-3/4 [857]	15-7/8 [403]
48HC-008	49-3/8 [1253]	36-3/8 [925]	15-7/8 [403]
48HC-009	49-3/8 [1253]	36-3/8 [925]	15-7/8 [403]

A	1 3/8" [35] DIA FIELD POWER SUPPLY HOLE
B	2 1/2" [64] DIA POWER SUPPLY KNOCKOUT
C	1 3/4" [45] DIA GAUGE ACCESS PLUG
D	7/8" [22] DIA. FIELD CONTROL WIRING HOLE
E	3/4" - 14 NPT GAS CONNECTION
F	3/4" - 14 NPT GAS CONNECTION
G	2" [51] DIA. POWER SUPPLY KNOCK-OUT

THREADED CONDUIT SIZE	WIRE USE	REQ'D HOLE SIZES (MAX.)
1/2"	ACC.	7/8" [22.2]
1/2"	24V	7/8" [22.2]
3/4"	(003) 1/2" (003)	1 1/8" [28.6]
1 1/4"	(002) 004	1 3/4" [44.4]
(003) 1/2" FPT	GAS	1 1/8" [28.6]
(004) 3/4" FPT	GAS	1 3/4" [44.4]
(001 & 002) PROVIDES 3/4" FPT THRU CURB FLANGE & FITTING. HOLE SIZE: 2" [50.8]		

THESE HOLES REQUIRED FOR USE WITH ACCT KITS:  
 CRBTMPR003A01: 08-09 GAS THRU CURB  
 CRBTMPR003A01: 07-09 GAS THRU CURB  
 CRBTMPR003A01: 07-09 GAS THRU BASEPAN  
 CRBTMPR004A01: 08-09 GAS THRU BASEPAN

FOR THRU-THE-BASEPAN\* FACTORY OPTION FITTINGS FOR ONLY X, Y, & Z ARE PROVIDED. \*\* FOR BELOW LISTED MODELS, A FIELD SUPPLIED 1/2" ADAPTER IS REQUIRED BETWEEN BASE PAN FITTING AND GAS VALVE: 48HC03, S-R-07 48HC05, S-09 48HC07, S-09

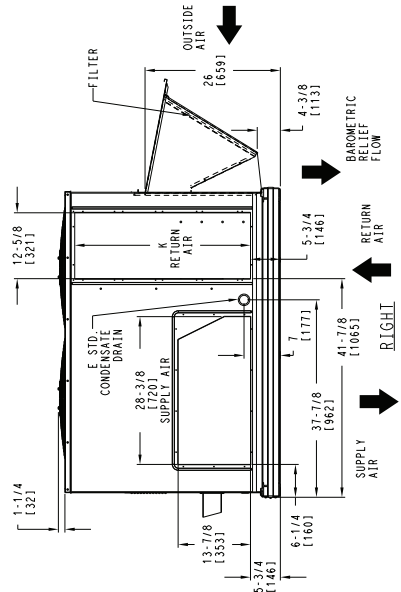
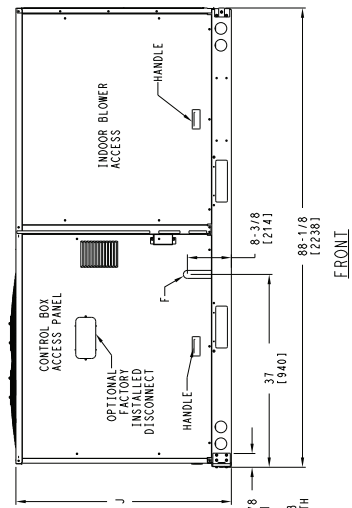
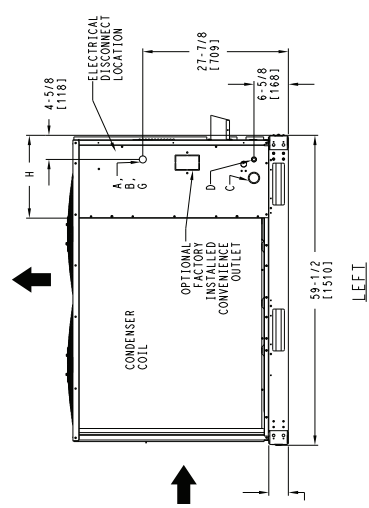
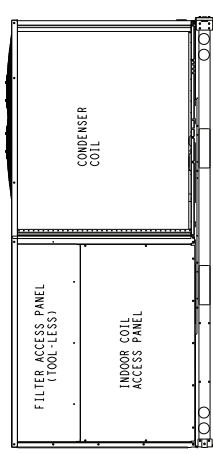
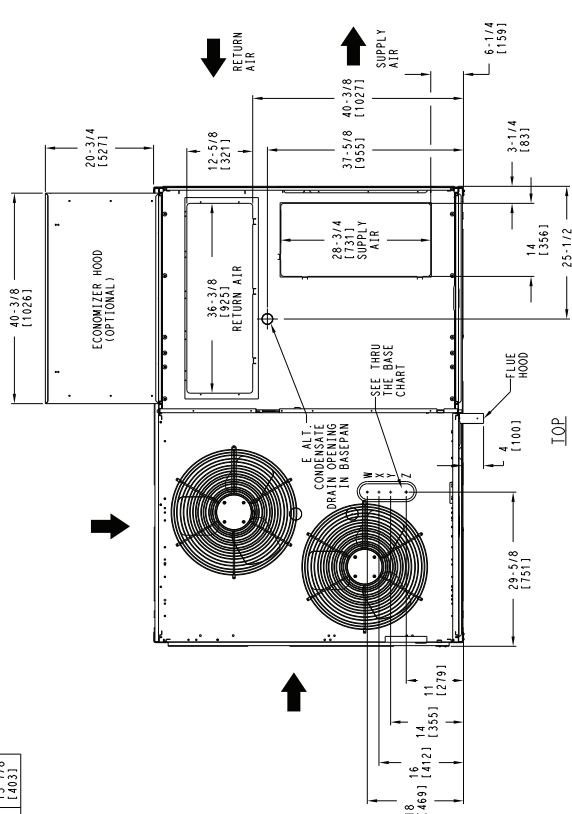

# Base unit dimensions (cont)



## 48HC\*\*07-09 BASE UNIT DIMENSIONS (cont)

UNIT	STD. UNIT WEIGHT *		CORNER WEIGHT (A)		CORNER WEIGHT (B)		CORNER WEIGHT (C)		CORNER WEIGHT (D)		C. G.								
	LBS.	KG.	LBS.	KG.	LBS.	KG.	LBS.	KG.	LBS.	KG.	X	Y	Z						
48HC-A, D07	765	347	165.3	75	152.7	69.3	214.7	97.4	232.3	105.4	42	3/8	110161	34	3/4	1882.6	19	7/8	505
48HC-D08	925	419.5	204.1	92.6	190.9	86.6	256.1	116.2	273.9	124.2	42	5/8	11082	34	1/8	1867	22	7/8	581
48HC-D09	925	419.5	204.1	92.6	190.9	86.6	256.1	116.2	273.9	124.2	42	5/8	11082	34	1/8	1867	22	7/8	581

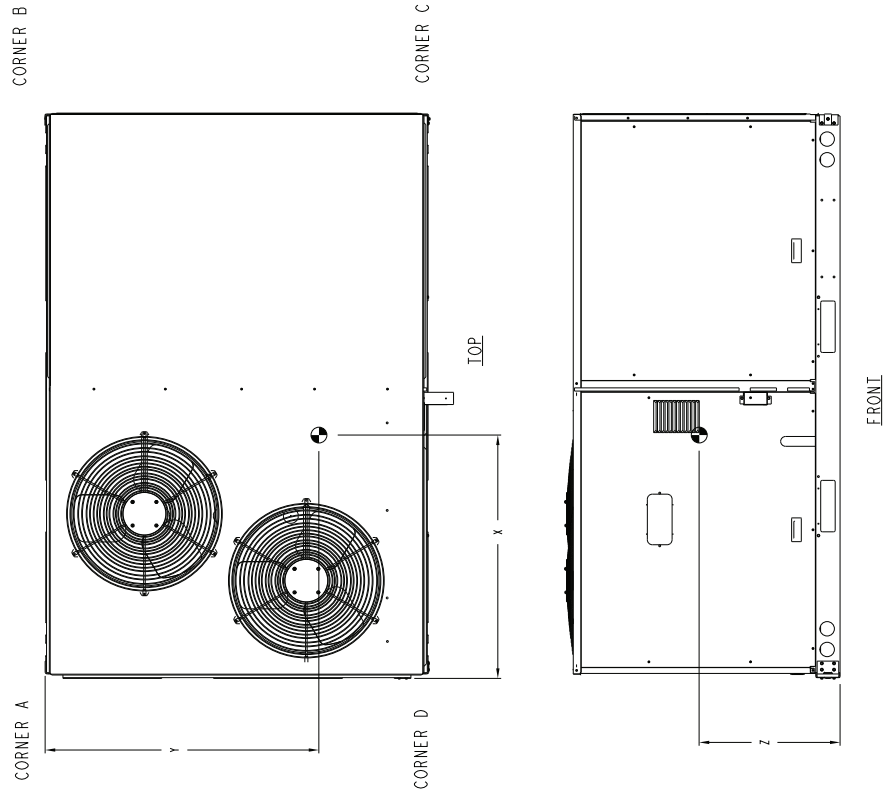

### 48HC\*\*07-09 BASE UNIT — SERVICE CLEARANCES

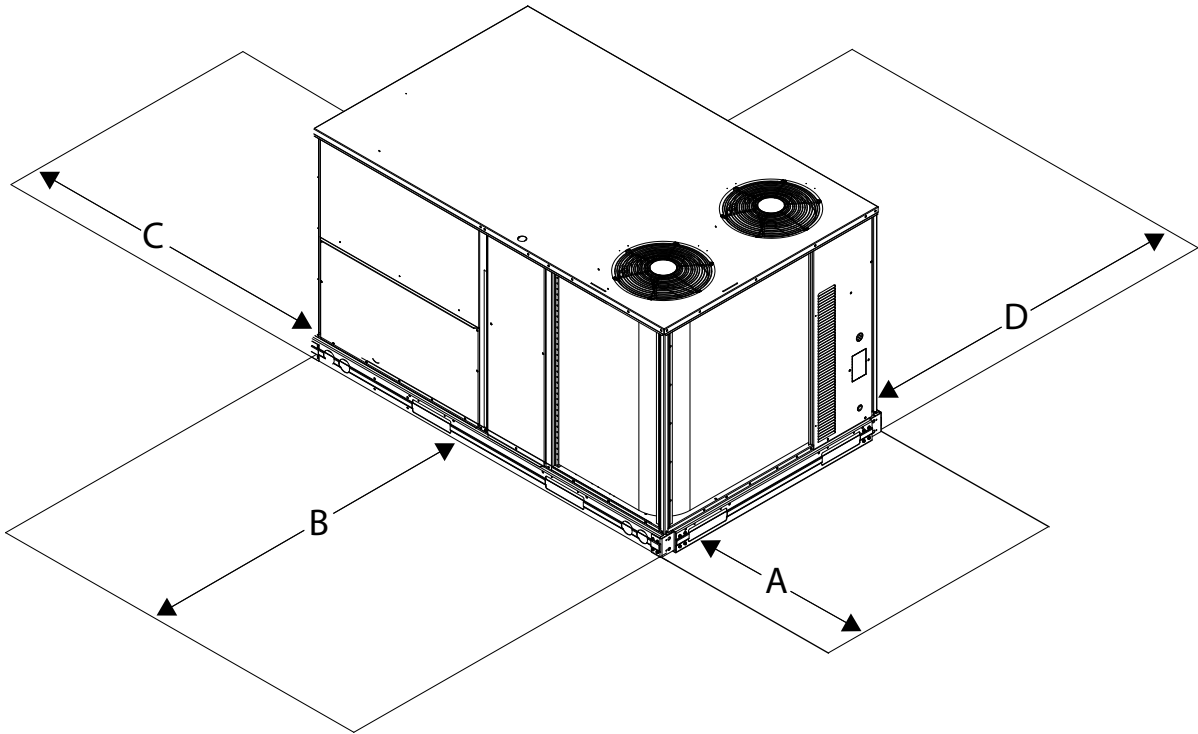

LOCATION	DIMENSION in. (mm)	CONDITION
A	48 (1219) 18 (457) 18 (457) 12 (305)	Unit disconnect is mounted on panel. No disconnect, convenience outlet option. Recommended service clearance. Minimum clearance.
B	42 (1067) 36 (914) Special	Surface behind servicer is grounded (e.g., metal, masonry wall). Surface behind servicer is electrically non-conductive (e.g., wood, fiberglass). Check for sources of flue products within 10-ft (3 m) of unit fresh air intake hood.
C	36 (914) 18 (457)	Side condensate drain is used. Minimum clearance.
D	48 (1219) 42 (1067) 36 (914) Special	No flue discharge accessory installed, surface is combustible material. Surface behind servicer is grounded (e.g., metal, masonry wall, another unit). Surface behind servicer is electrically non-conductive (e.g., wood, fiberglass). Check for adjacent units or building fresh air intakes within 10-ft (3 m) of this unit's flue outlet.

NOTE: Unit is not designed to have overhead obstruction. Contact Application Engineering for guidance on any application planning overhead obstruction or for vertical clearances.

# Base unit dimensions (cont)



## 48HC\*\*11-12 BASE UNIT DIMENSIONS

NOTES:

1. DIMENSIONS ARE IN INCHES, DIMENSIONS IN [ ] ARE IN MILLIMETERS.
2. CENTER OF GRAVITY
3. DIRECTION OF AIR FLOW

CONNECTION SIZES	
A	1 3/8" [35] DIA. FIELD POWER SUPPLY HOLE
B	2 1/2" [64] DIA. POWER SUPPLY KNOCKOUT
C	1 3/4" [51] DIA. GAUGE ACCESS PLUG
D	7/8" [22] DIA. FIELD CONTROL WIRING HOLE
E	3/4" -14 NPT CONDENSATE DRAIN
F	3/4" -14 NPT GAS CONNECTION
G	2" [51] DIA. POWER SUPPLY KNOCK-OUT

THRU-THE-BASE CHART FOR USE WITH WIRE SIZES (SEE TABLE 094401)	
WIRE SIZE (MAX.)	THREADED CONDUIT SIZE
ACC. 7/8" [22.2]	1 1/2"
24V 7/8" [22.2]	1 1/2"
POWER 1 3/4" [44.4]	1 1/4" (002, 004)
GAS 1 5/8" [41.3]	(004) 3/4" FPT

FOR "THRU-THE-BASE" FACTORY OPTION, FITTINGS FOR ONLY X, Y, & Z ARE PROVIDED.

(002) PROVIDES 3/4" FPT THRU CURB FLANGE & FITTING.

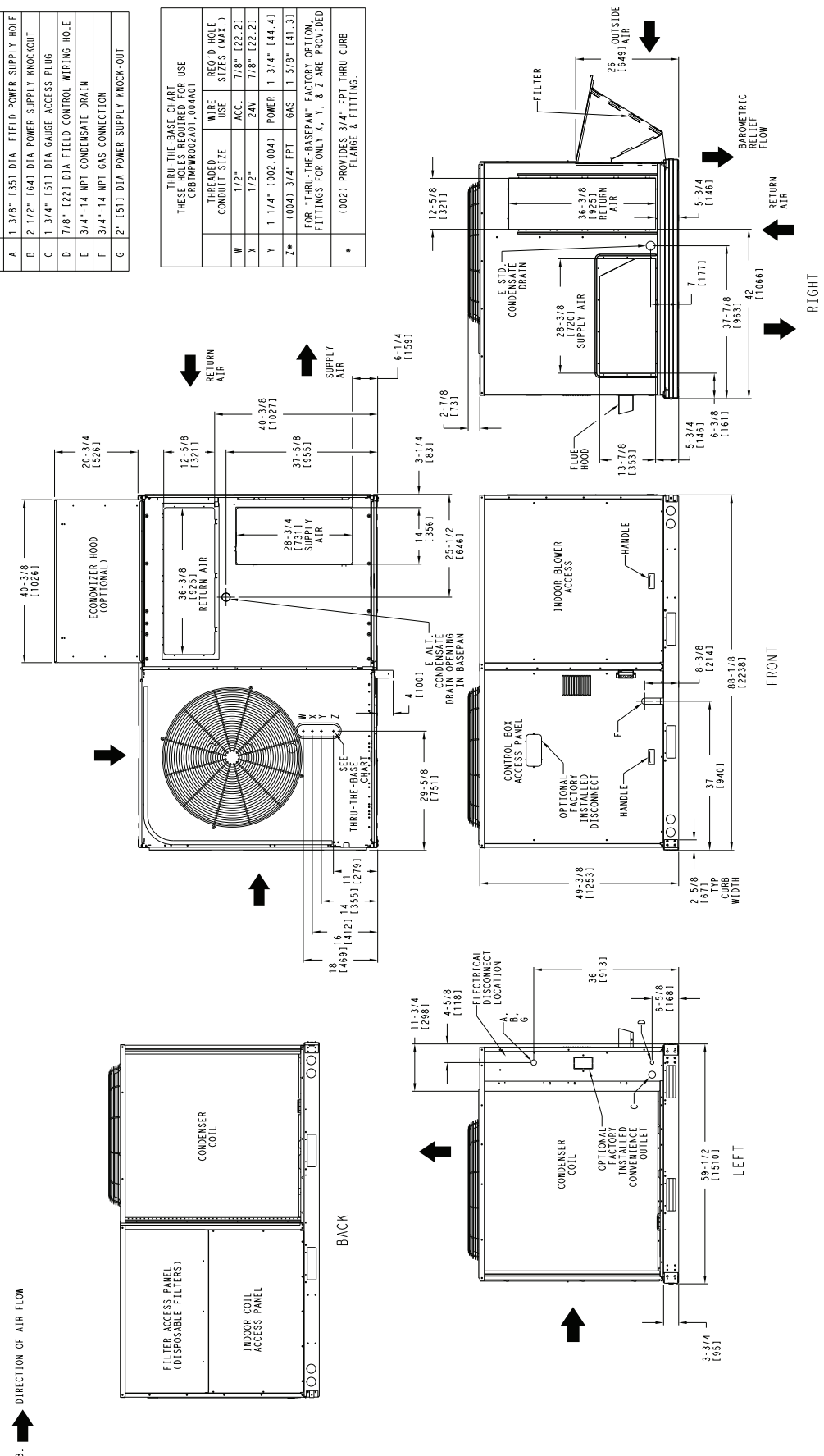

### 48HC\*\*11-12 BASE UNIT DIMENSIONS (cont)

UNIT	STD. UNIT WEIGHT (GROSS)		CORNER A WEIGHT (GROSS)		CORNER B WEIGHT (GROSS)		CORNER C WEIGHT (GROSS)		CORNER D WEIGHT (GROSS)		C.G.	
	LBS.	KG.	LBS.	KG.	LBS.	KG.	LBS.	KG.	LBS.	KG.	X	Y
48HC-D12	1090	495	311	142	162	74	211	96	405	184	30 1/8 [766]	33 5/8 [855]
48HC-D11	1090	495	311	142	162	74	211	96	405	184	30 1/8 [766]	33 5/8 [855]

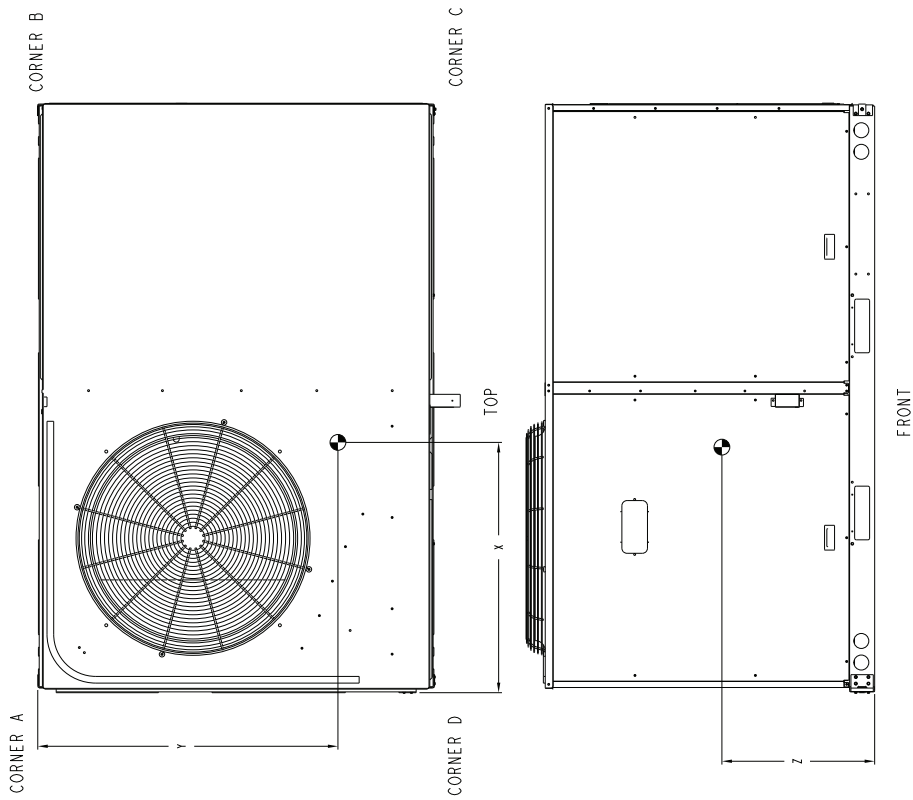

## 48HC\*\*11-12 BASE UNIT SERVICE CLEARANCES

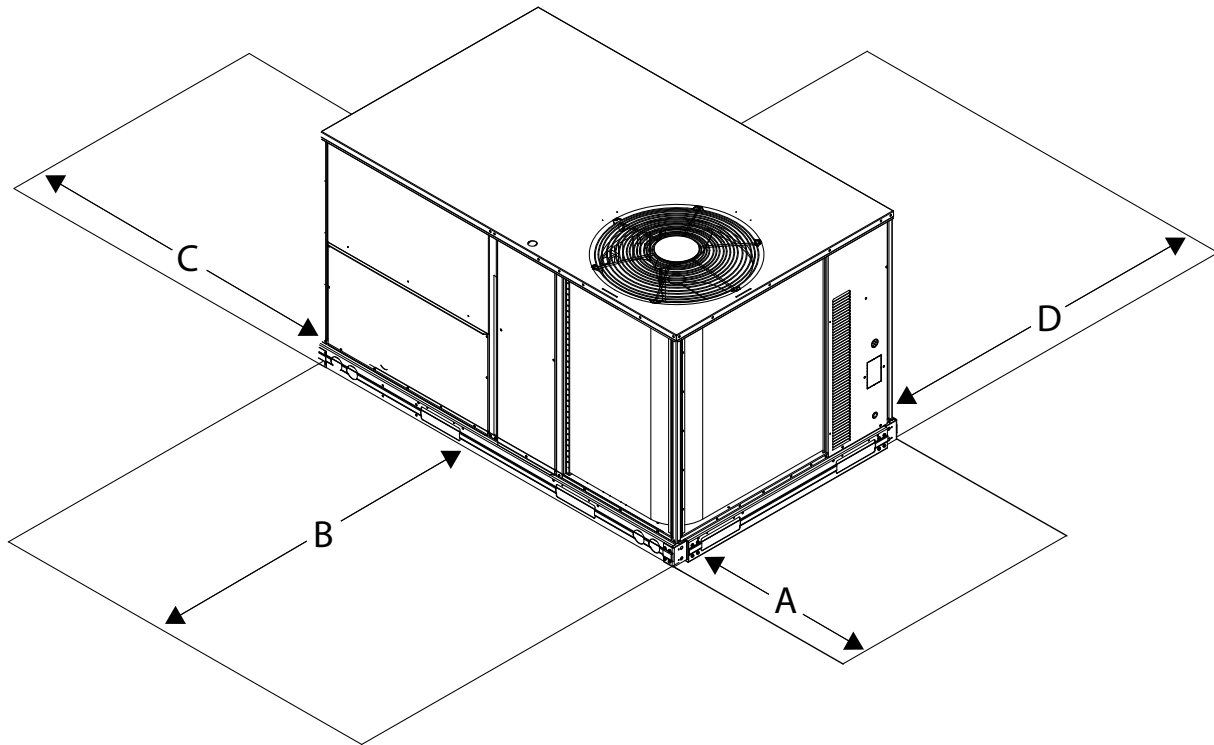

LOCATION	DIMENSION in. (mm)	CONDITION
A	48 (1219) 18 (457) 18 (457) 12 (305)	Unit disconnect is mounted on panel. No disconnect, convenience outlet option. Recommended service clearance. Minimum clearance.
B	42 (1067) 36 (914) Special	Surface behind servicer is grounded (e.g., metal, masonry wall). Surface behind servicer is electrically non-conductive (e.g., wood, fiberglass). Check for sources of flue products within 10-ft (3 m) of unit fresh air intake hood.
C	36 (914) 18 (457)	Side condensate drain is used. Minimum clearance.
D	48 (1219) 42 (1067) 36 (914) Special	No flue discharge accessory installed, surface is combustible material. Surface behind servicer is grounded (e.g., metal, masonry wall, another unit). Surface behind servicer is electrically non-conductive (e.g., wood, fiberglass). Check for adjacent units or building fresh air intakes within 10-ft (3 m) of this unit's flue outlet.

NOTE: Unit is not designed to have overhead obstruction. Contact Application Engineering for guidance on any application planning overhead obstruction or for vertical clearances.



# 48HC\*\*14 BASE UNIT DIMENSIONS

- NOTES:
1. DIMENSIONS ARE IN INCHES. DIMENSIONS IN ( ) ARE IN MILLIMETERS.
  2. CENTER OF GRAVITY
  3. DIRECTION OF AIR FLOW

CONNECTION SIZES	
B	2 1/2" [64] DIA POWER SUPPLY HOLE
D	7/8" [22] DIA FIELD CONTROL WIRING HOLE
E	3/4" - 14 NPT CONDENSATE DRAIN
F	7/8" [22] DIA FIELD CONVENIENCE OUTLET HOLE
G	3/4" - 14 NPT GAS CONNECTION

THRU-THE-BASE CHART THESE HOLES REQUIRED FOR USE CROSS REFERENCE TO 007A001.007A00			
ACCESSORY NO.	THREADED CONDUIT SIZE	WIRE USE	REQ'D HOLE SIZES (MAX.)
005	W 1/2"	ACC.	7/8" [22.2]
	X 1/2"	24V	7/8" [22.2]
	Y 1 1/4"	POWER	1 1/2" [38.1]
006	Z 3/4" PIPE	GAS	1 3/4" [44.5]
	W 1/2"	ACC.	7/8" [22.2]
	X 1/2"	24V	7/8" [22.2]
007	Y 1 1/2"	POWER	2" [50.8]
	Z 3/4" PIPE	GAS	1 3/4" [44.5]
	W 1/2"	ACC.	7/8" [22.2]
	X 1/2"	24V	7/8" [22.2]
	Y 2"	POWER	2 1/2" [63.5]
	Z 3/4" PIPE	GAS	1 3/4" [44.5]

FOR THRU-THE-BASEMAN FACTORY INSTALLED FITTINGS FOR "X" ARE PROVIDED AS SPECIFIED ON "006".

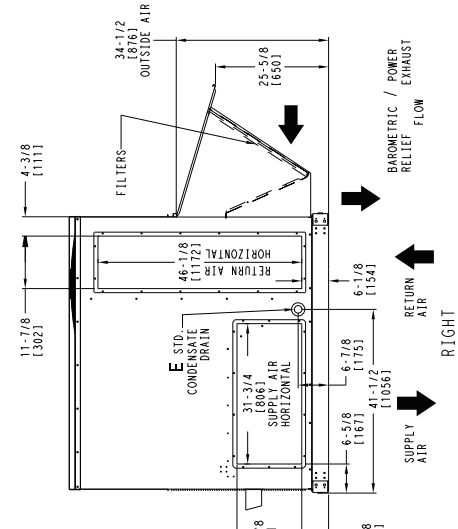
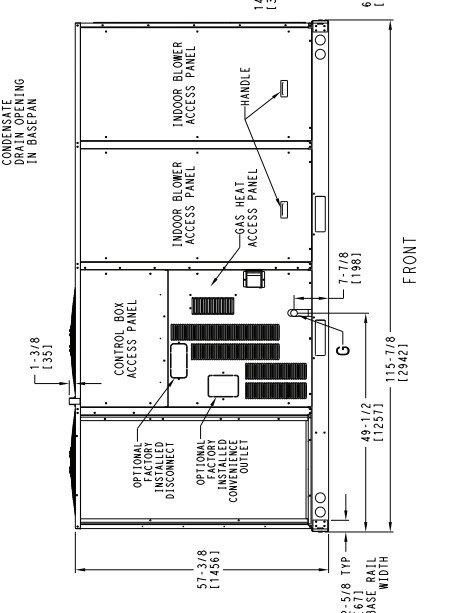
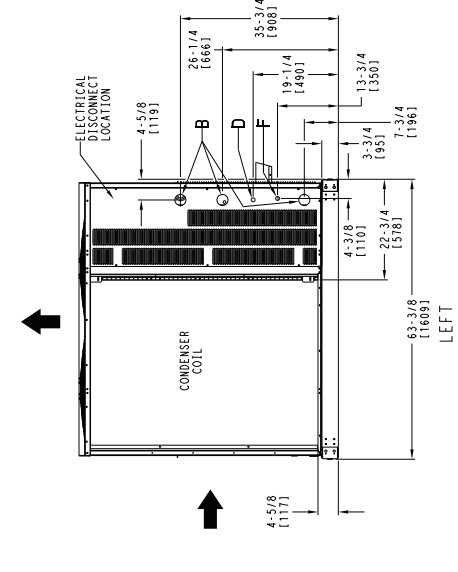
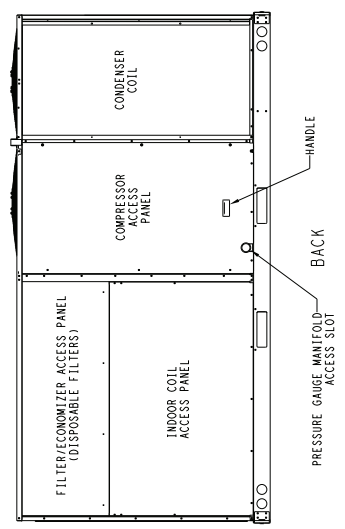
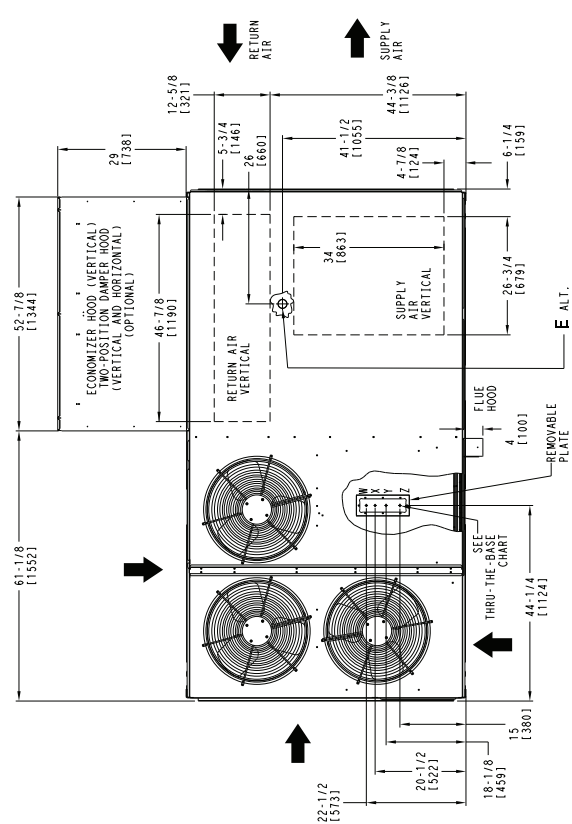

## 48HC\*\*14 BASE UNIT DIMENSIONS (cont)

UNIT	CORNER WEIGHT (A)		CORNER WEIGHT (B)		CORNER WEIGHT (C)		CORNER WEIGHT (D)		C.G.				
	LBS.	KG.	LBS.	KG.	LBS.	KG.	LBS.	KG.	X	Y	Z		
48HC14	1430	649	342	155	377	171	372	169	338	153	60 3/4 [1543]	31 1/2 [800]	20 5/8 [524]

STANDARD UNIT WEIGHT IS WITHOUT MAX. GAS HEAT & WITHOUT PACKAGING. FOR OPTIONS & ACCESSORIES, REFER TO THE PRODUCT DATA CATALOG.

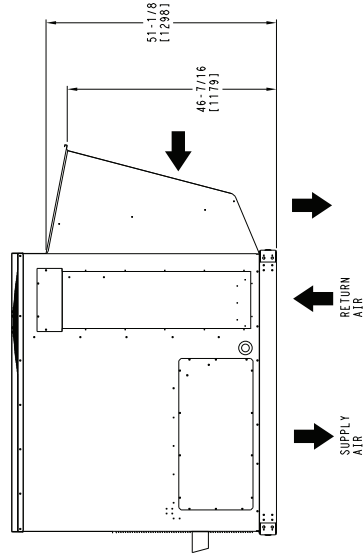
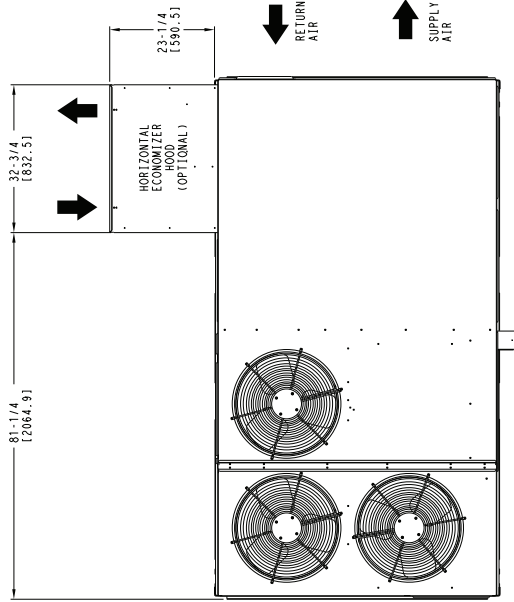
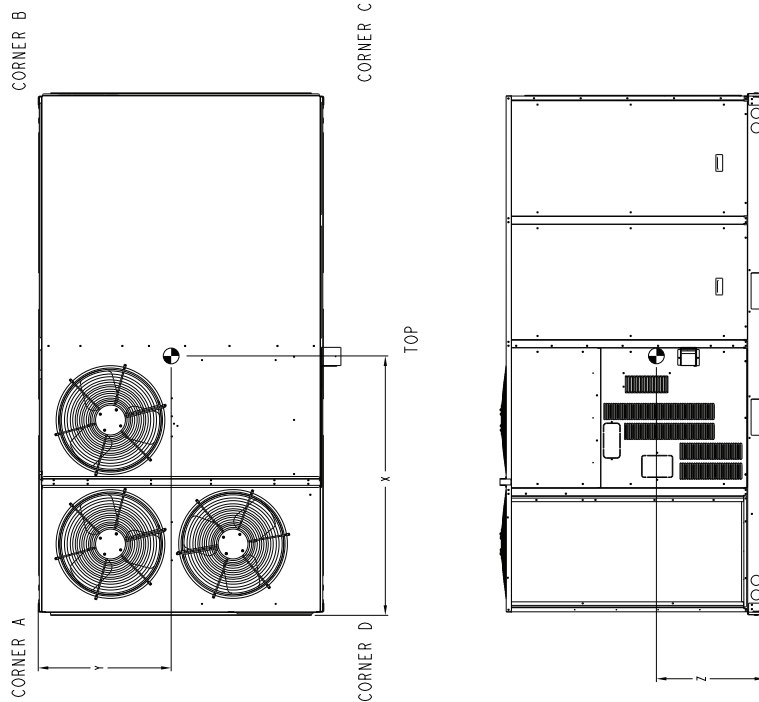

HORIZONTAL ECONOMIZER

### 48HC\*\*14 BASE UNIT SERVICE CLEARANCES

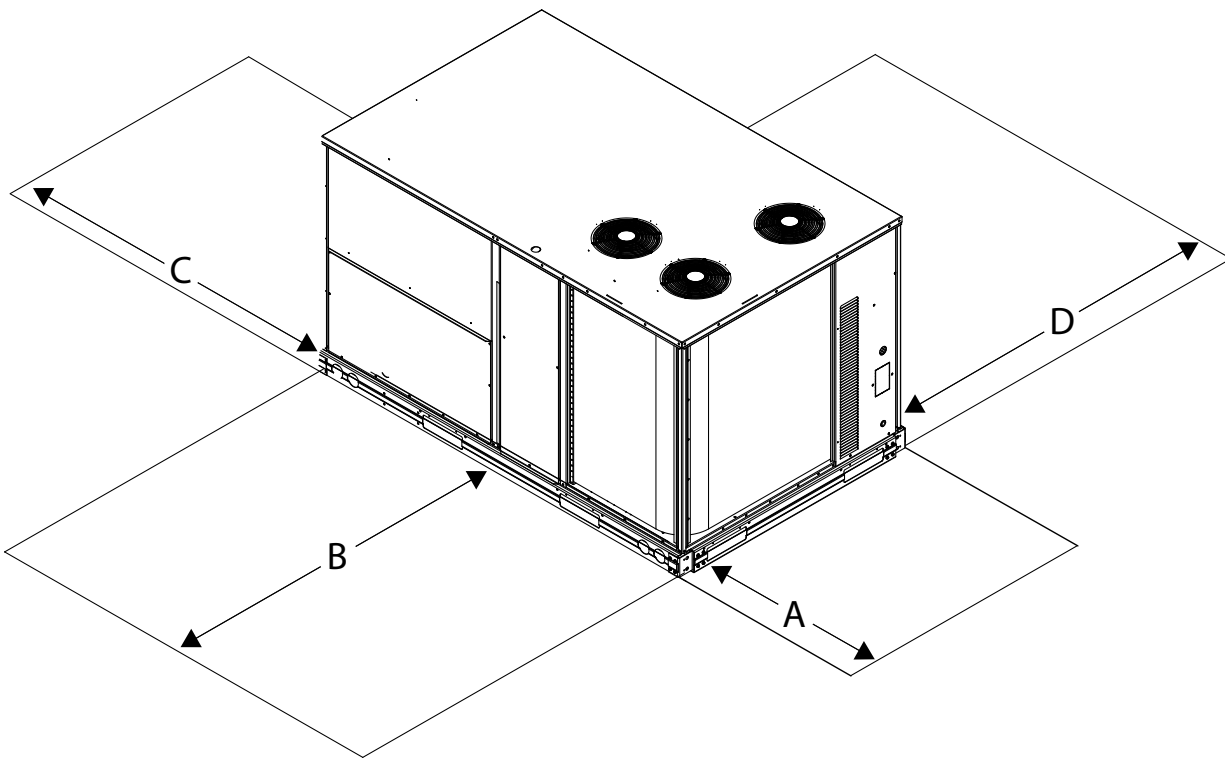

LOCATION	DIMENSION in. (mm)	CONDITION
A	48 (1219) 18 (457) 18 (457) 12 (305)	Unit disconnect is mounted on panel No disconnect, convenience outlet option Recommended service clearance Minimum clearance
B	42 (1067) 36 (914) Special	Surface behind servicer is grounded (e.g., metal, masonry wall). Surface behind servicer is electrically non-conductive (e.g., wood, fiberglass). Check for sources of flue products within 10-ft (3 m) of unit fresh air intake hood.
C	36 (914) 18 (457)	Side condensate drain is used. Minimum clearance.
D	48 (1219) 42 (1067) 36 (914) Special	No flue discharge accessory installed, surface is combustible material. Surface behind servicer is grounded (e.g., metal, masonry wall, another unit). Surface behind servicer is electrically non-conductive (e.g., wood, fiberglass). Check for adjacent units or building fresh air intakes within 10-ft (3 m) of this unit's flue outlet.

NOTE: Unit is not designed to have overhead obstruction. Contact Application Engineering for guidance on any application planning overhead obstruction or for vertical clearances.

# Base unit dimensions (cont)



## 48HC\*\*04-06 WITH ENERGYX® SYSTEM UNIT DIMENSIONS

- NOTES:  
 1. DIMENSIONS ARE IN INCHES, DIMENSIONS IN L, J ARE IN MILLIMETERS.  
 2. CENTER OF GRAVITY  
 3. DIRECTION OF AIR FLOW

UNIT	J	K	L	M	N
48HC-A04	33-3/8 (847)	18-5/8 (472)	35-3/8 (899)	48-1/2 (1233)	29-1/4 (744)
48HC-A05	41-3/8 (1051)	14-7/8 (377)	35-1/2 (903)	52-1/2 (1333)	37 (941)
48HC-A06					

CONNECTION SIZES	
A	1-3/8" (35) DIA. FIELD POWER SUPPLY HOLE
B	2" (50) DIA. POWER SUPPLY KNOCKOUT
C	1-3/4" (51) DIA. GAUGE ACCESS PLUG
D	7/8" (22) DIA. FIELD CONTROL WIRING HOLE
E	3/4" x 1/4 NPT CONDENSATE DRAIN
F	1/2" x 1/4 NPT GAS CONNECTION
G	2-1/2" (64) DIA. POWER SUPPLY KNOCK-OUT

THRU-THE-BASE CHART THESE HOLES REQUIRED FOR USE CRBTMWR008A00...009A00			
W	THREADED CONDUIT SIZE	WIRE USE	REQ'D HOLE SIZES (MAX.)
X	1/2"	ACC.	7/8" (22, 21)
Y	1-1/4"	2AV	7/8" (22, 21)
Z	(008) 1/2" FPT	POWER	1-23/32" (47, 31)
Z*	(008) 1/2" FPT	GAS	1-3/16" (30, 01)

FOR THRU-THE-BASE FACTORY OPTIMIZED FITTINGS FOR ONLY X, Y, & Z ARE PROVIDED (009) PROVIDES 3/4" FPT THRU CURB FLANGE & FITTING.

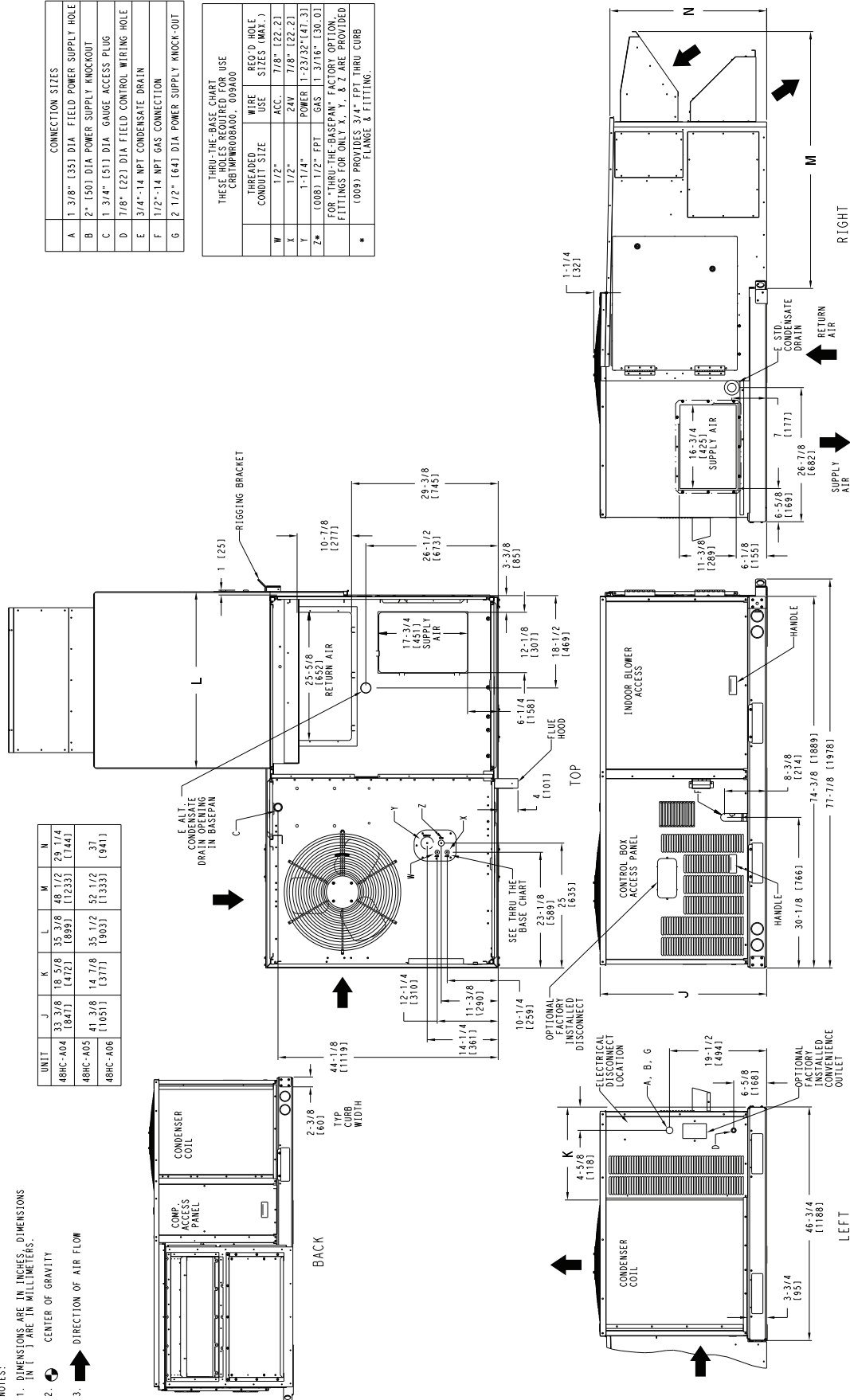

### 48HC\*\*04-06 WITH ENERGYX® SYSTEM UNIT DIMENSIONS (cont)

UNIT	STD. UNIT WEIGHT*		CORNER WEIGHT (A)		CORNER WEIGHT (B)		CORNER WEIGHT (C)		CORNER WEIGHT (D)		C.G.		
	LBS.	KG.	LBS.	KG.	LBS.	KG.	LBS.	KG.	LBS.	KG.	X	Y	Z
48HC-A04	969	440	317	144	529	241	77	35	46	21	46 1/2 (1181)	5 7/8 (151)	19 (483)
48HC-A05	1240	564	415	189	742	337	53	24	30	13	47 3/4 (1212)	3 1/8 (79)	20 1/8 (511)
48HC-A06	1250	568	422	192	742	337	55	25	31	14	47 3/8 (1205)	3 1/4 (82)	19 1/2 (496)

\*- STANDARD UNIT WEIGHT IS WITH LOW GAS HEAT AND WITHOUT PACKAGING.  
FOR OTHER OPTINS AND ACCESSORIES REFER TO THE PRODUCT DATA CATALOG.

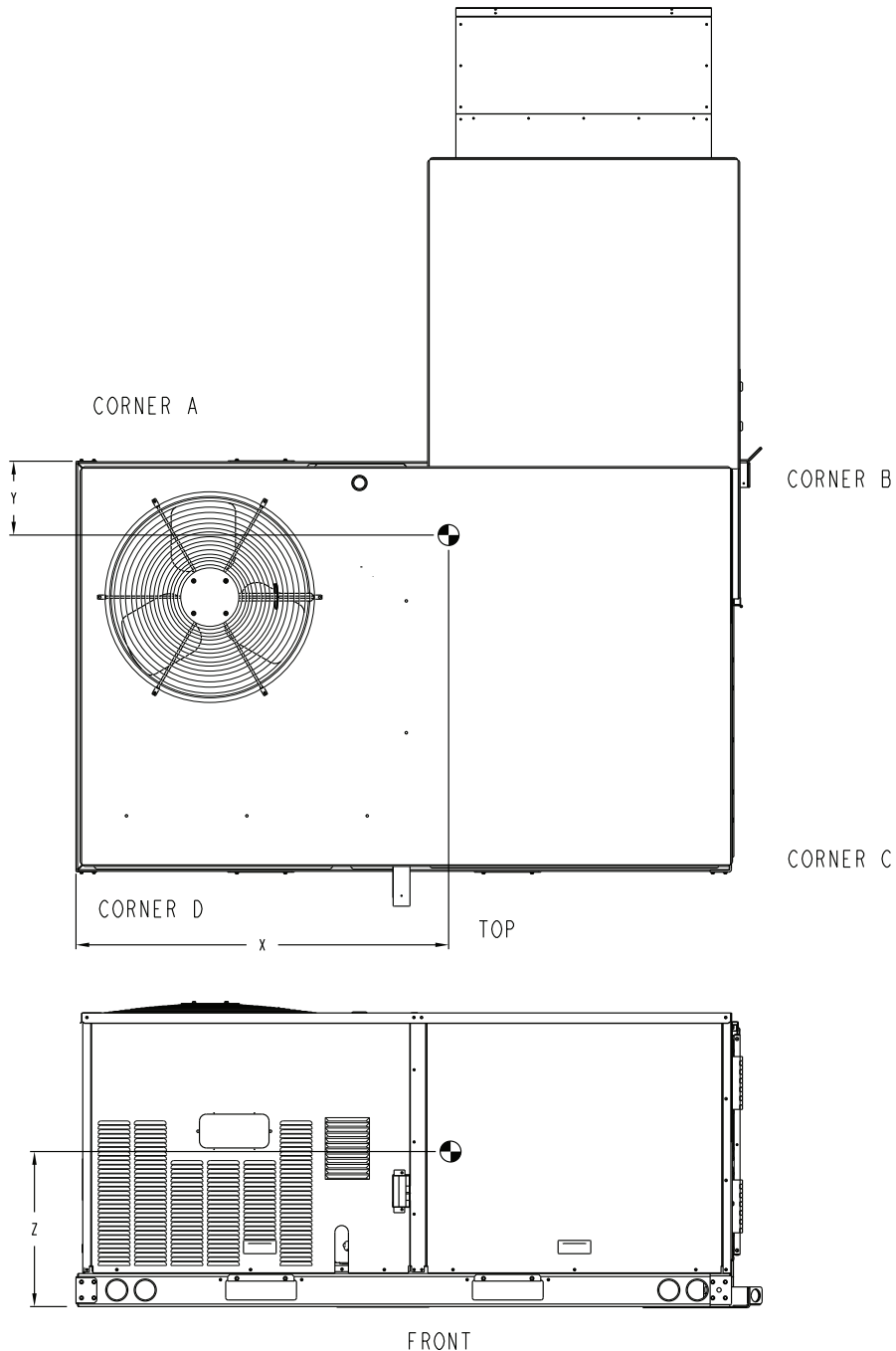

## SERVICE CLEARANCES — 48HC\*\*04-06 WITH ENERGYX® SYSTEM

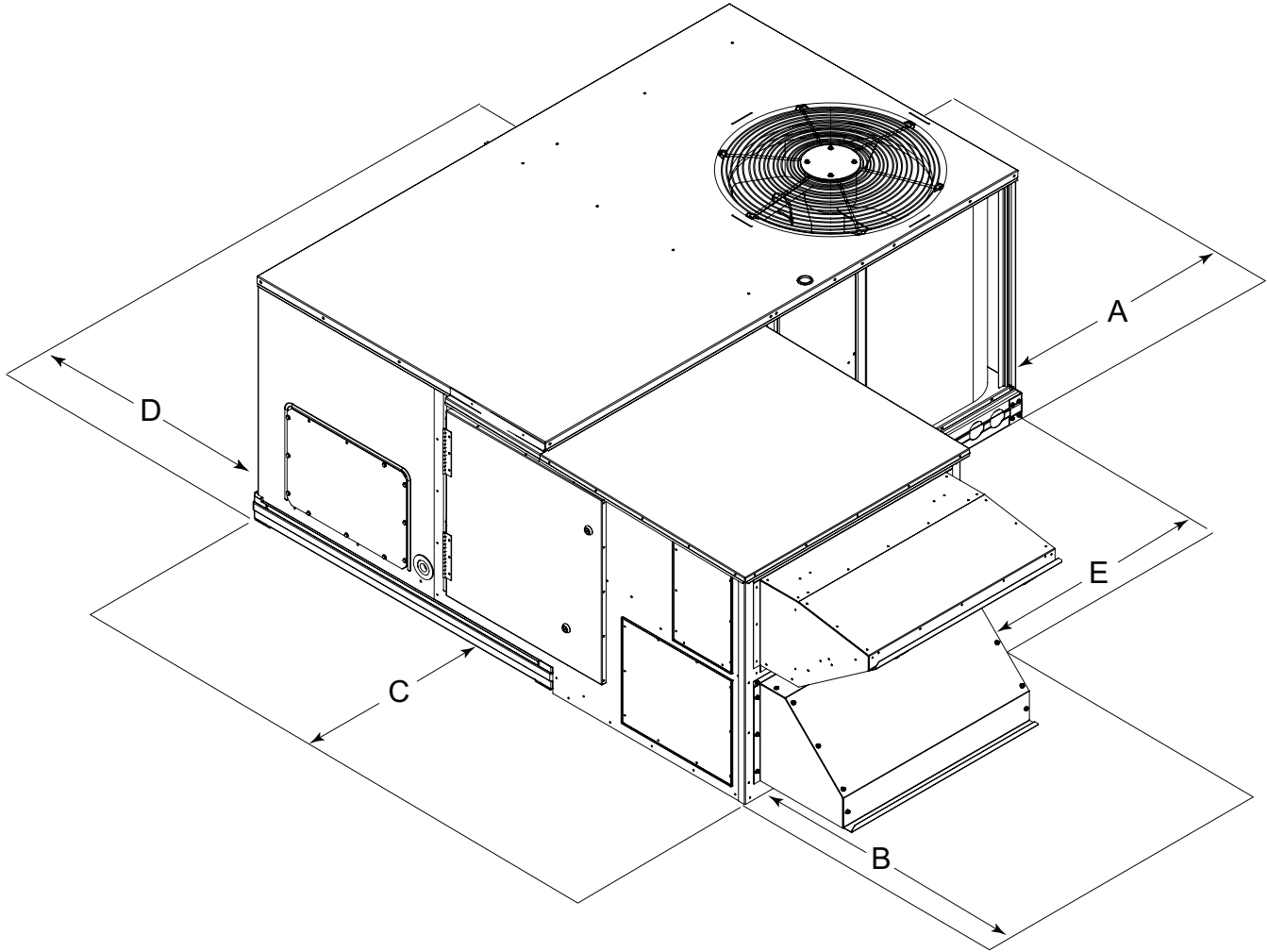

LOCATION	DIMENSION in. (mm)	CONDITION
A	48 (1219)	Unit disconnect is mounted on panel. No disconnect, convenience outlet option. Recommended service clearance. Minimum clearance.
	18 (457)	
	18 (457)	
	12 (305)	
B	36 (914)	Recommended service clearance.
C	36 (914)	Recommended service clearance.
D	48 (1219)	No flue discharge accessory installed, surface is combustible material. Surface behind servicer is grounded (e.g., metal, masonry wall, another unit). Surface behind servicer is electrically non-conductive (e.g., wood, fiberglass). Check for adjacent units or building fresh air intakes within 10-ft (3 m) of this unit's flue outlet.
	42 (1067)	
	36 (914) Special	
E	36 (914)	Recommended service clearance.

NOTE: Unit is not designed to have overhead obstruction. Contact Application Engineering for guidance on any application planning overhead obstruction or for vertical clearances.

# 48HC\*\*07 WITH ENERGYX® SYSTEM UNIT DIMENSIONS

- NOTES:
1. DIMENSIONS ARE IN INCHES. DIMENSIONS IN PARENTHESIS ARE IN MILLIMETERS.
  2. CENTER OF GRAVITY
  3. DIRECTION OF AIR FLOW

CONNECTION SIZES	
A	3/8" (133) DIA FIELD POWER SUPPLY HOLE
B	2 1/2" (64) DIA POWER SUPPLY KNOCKOUT
C	1 3/4" (51) DIA GAUGE ACCESS PLUG
D	7/8" (22) DIA FIELD CONTROL WIRING HOLE
E	3/4" - 14 NPT CONDENSATE DRAIN
F	1/2" - 14 NPT GAS CONNECTION
G	3/4" - 14 NPT GAS CONNECTION
H	2" (51) DIA POWER SUPPLY KNOCK-OUT

THRU-THE-BASE CHART (FIELD INST)	
THESE HOLES REQUIRED FOR USE WITH ACCY KITS:	
C08THRU03A01: 07 - GAS THRU CURB	
C08THRU03A01: 07 - GAS THRU BASEPAN	
THREADED CONDUIT SIZE	REQ'D HOLE SIZES (MAX.)
W	1/2" ACC. 7/8" (22.2)
X	1/2" 24V 7/8" (22.2)
Y	3/4" POWER 1 1/8" (28.6)
Z *	1/2" FPT GAS 1 1/8" (28.6)
* (081) PROVIDES 3/4" FPT THRU CURB FLANGE & FITTING. HOLE SIZE - 2" (50.8)	

THRU-THE-BASE CHART (FLOP)	
FOR THRU-THE-BASEPAN, FACTORY OPTION, FITTINGS FOR ONLY X, Y, & Z ARE PROVIDED. **	
FOR THRU-THE-BASEPAN, FACTORY OPTION, FITTINGS FOR ONLY X, Y, & Z ARE PROVIDED. **	
FOR THRU-THE-BASEPAN, FACTORY OPTION, FITTINGS FOR ONLY X, Y, & Z ARE PROVIDED. **	
** 48HCD.E.S.R-07	

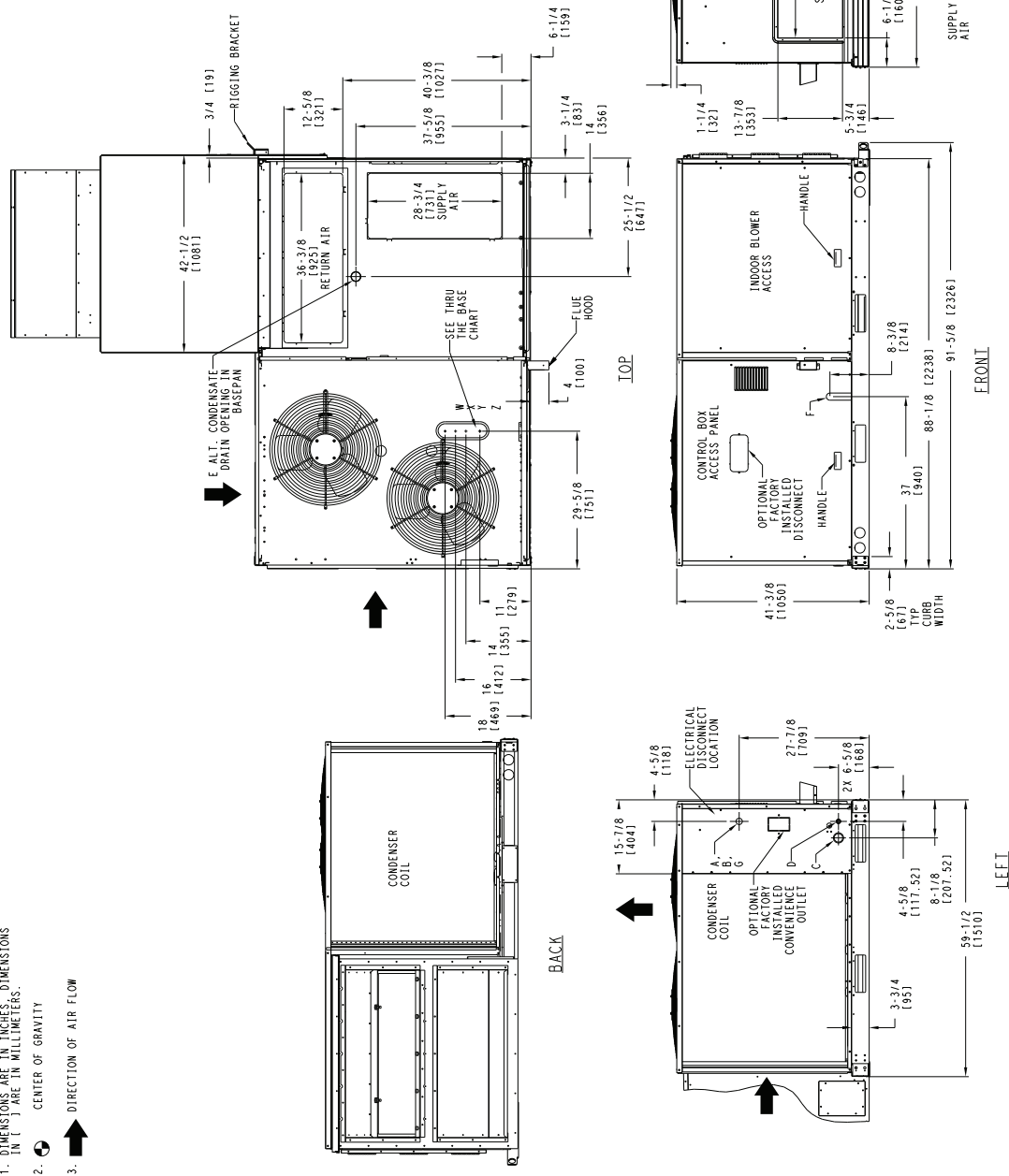

## 48HC\*\*07 WITH ENERGYX® SYSTEM UNIT DIMENSIONS (cont)

UNIT	STD. UNIT WEIGHT *		CORNER WEIGHT (A)		CORNER WEIGHT (B)		CORNER WEIGHT (C)		CORNER WEIGHT (D)		C.G.		
	LBS.	KG.	LBS.	KG.	LBS.	KG.	LBS.	KG.	LBS.	KG.	X	Y	Z
48HC-A07	1435	652	441	200	679	309	191	87	124	56	53 3/8 (1357)	13 (332)	19 7/8 (505)

\* STANDARD UNIT WEIGHT IS WITH LOW GAS HEAT AND WITHOUT PACKAGING.  
FOR OTHER OPTIONS AND ACCESSORIES, REFER TO THE PRODUCT DATA CATALOG.

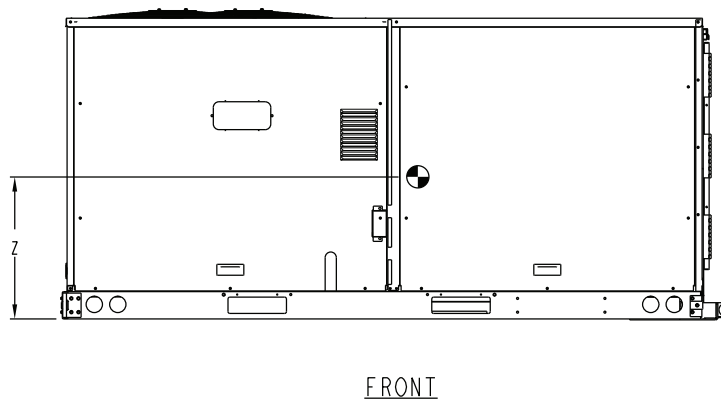
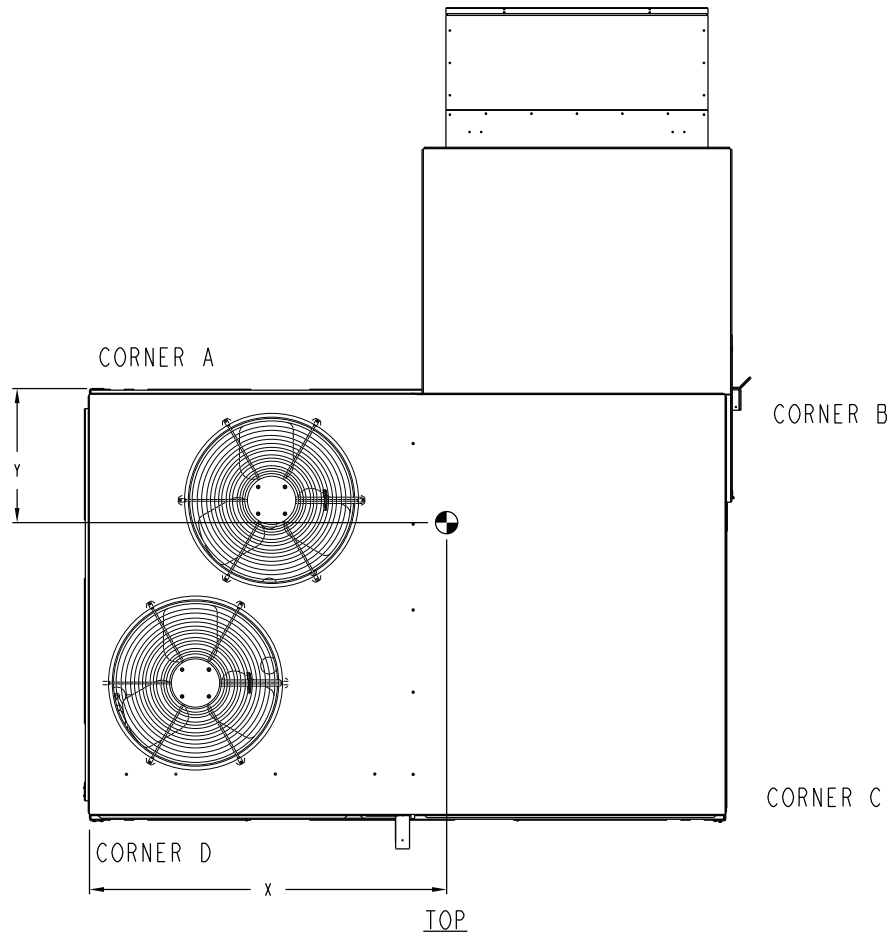



**SERVICE CLEARANCES — 48HC\*\*07 UNITS WITH ENERGYX® SYSTEM**

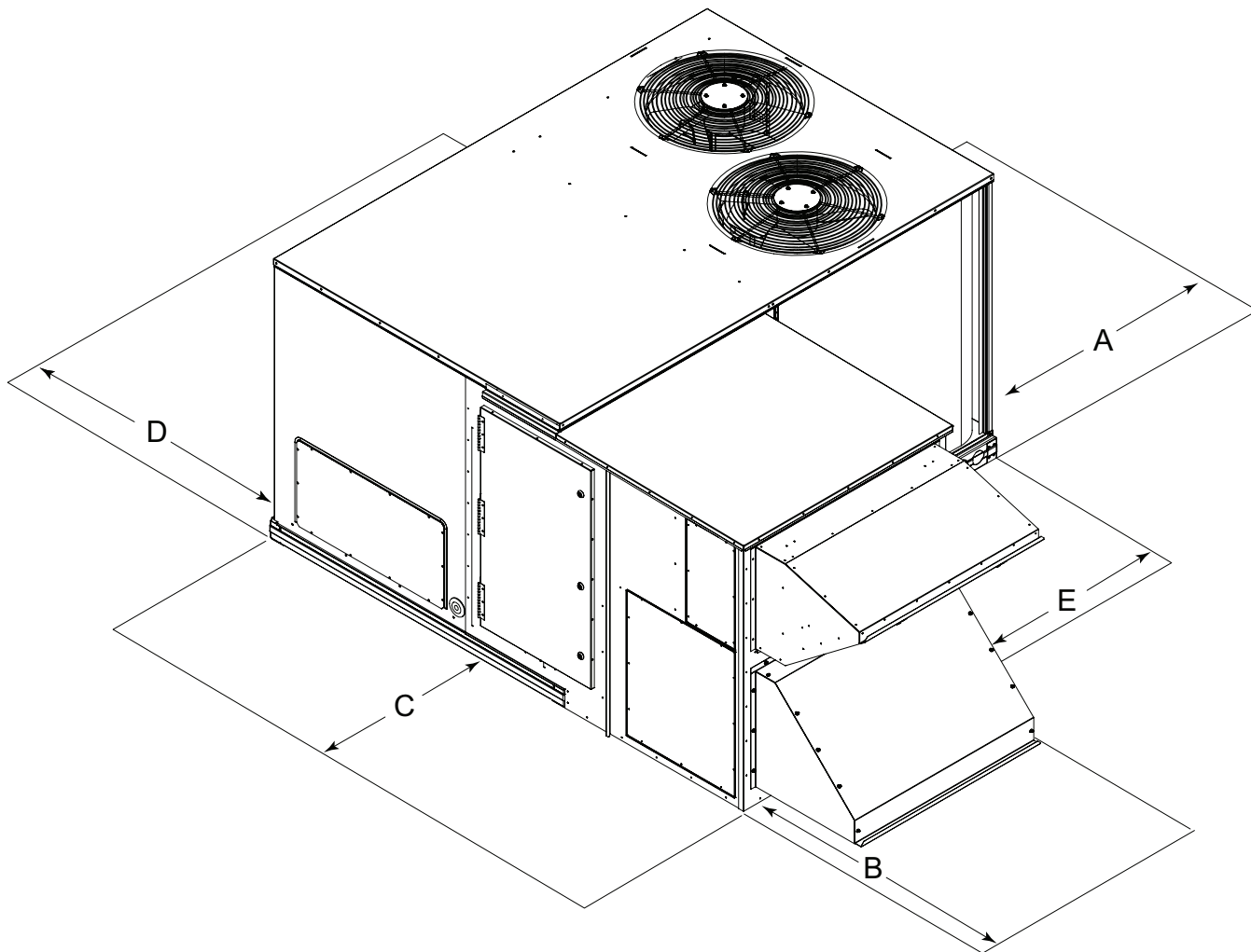

LOCATION	DIMENSION in. (mm)	CONDITION
A	48 (1219)	Unit disconnect is mounted on panel.
	18 (457)	No disconnect, convenience outlet option.
	18 (457)	Recommended service clearance.
	12 (305)	Minimum clearance.
B	36 (914)	Recommended service clearance.
C	36 (914)	Recommended service clearance.
D	48 (1219)	No flue discharge accessory installed, surface is combustible material.
	42 (1067)	Surface behind servicer is grounded (e.g., metal, masonry wall, another unit).
	36 (914) Special	Surface behind servicer is electrically non-conductive (e.g., wood, fiberglass). Check for adjacent units or building fresh air intakes within 10-ft (3 m) of this unit's flue outlet.
E	36 (914)	Recommended service clearance.

NOTE: Unit not designed to have overhead obstruction. Contact Application Engineering for guidance on any application planning overhead obstruction or for vertical clearances.

# Base unit dimensions (cont)



## 48HC\*\*08-12 WITH ENERGYX® SYSTEM UNIT DIMENSIONS

- NOTES:
1. DIMENSIONS ARE IN INCHES. DIMENSIONS IN ( ) ARE IN MILLIMETERS.
  2. ○ CENTER OF GRAVITY
  3. ↑ DIRECTION OF AIR FLOW

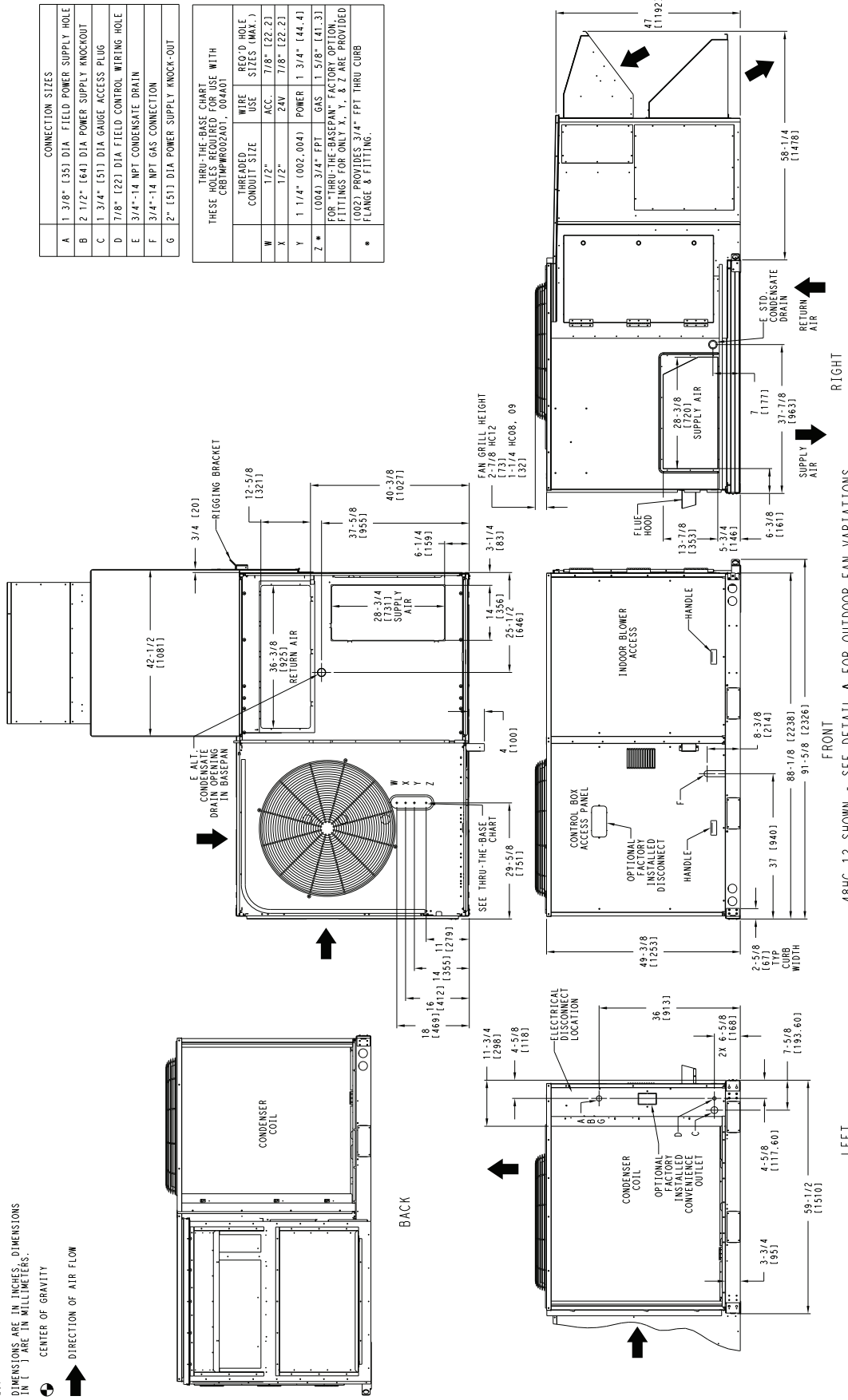

CONNECTION SIZES	
A	1 3/8" (35) DIA. FIELD POWER SUPPLY HOLE
B	2 1/2" (64) DIA. POWER SUPPLY KNOCKOUT
C	1 3/4" (51) DIA. GAUGE ACCESS PLUG
D	7/8" (22) DIA. FIELD CONTROL WIRING HOLE
E	3/4"-14 NPT CONDENSATE DRAIN
F	3/4"-14 NPT GAS CONNECTION
G	2" (51) DIA. POWER SUPPLY KNOCK-OUT

THRU-THE-BASE CHART	
THESE HOLES REQUIRED FOR USE WITH CURB IMPROVIZADIT, D04A01	
WIRE USE	REC'D HOLE SIZES (MAX.)
THREADED CONDUIT SIZE	7/8" (22.2)
1/2"	ACC. 7/8" (22.2)
1/2"	24V 7/8" (22.2)
W	1 1/4" (002.004) POWER 1 3/4" (44.4)
X	(004) 3/4" FPT GAS 1 5/8" (41.3)
Y	1 1/4" (002.004) POWER 1 3/4" (44.4)
Z	(004) 3/4" FPT GAS 1 5/8" (41.3)

FOR \*THRU-THE-BASEPAN\* FACTORY OPTION, FITTINGS FOR ONLY X, Y, & Z ARE PROVIDED (002) PROVIDES 3/4" FPT THRU CURB FLANGE & FITTING.

### 48HC\*\*08-12 WITH ENERGYX® SYSTEM UNIT DIMENSIONS (cont)

UNIT	STD. UNIT WEIGHT *		CORNER WEIGHT (A)		CORNER WEIGHT (B)		CORNER WEIGHT (C)		CORNER WEIGHT (D)		C.G.		
	LBS.	KG.	LBS.	KG.	LBS.	KG.	LBS.	KG.	LBS.	KG.	X	Y	Z
48HC-D08	1794	815	598	272	946	430	153	70	97	44	54 (1371)	8 1/4 (211)	22 7/8 (582)
48HC-D09	1794	815	598	272	946	430	153	70	97	44	54 (1371)	8 1/4 (211)	22 7/8 (582)
48HC-D11	1959	890	773	352	849	386	176	80	161	73	46 1/8 (1171)	10 1/4 (260)	20 3/4 (528)
48HC-D12	1959	890	773	352	849	386	176	80	161	73	46 1/8 (1171)	10 1/4 (260)	20 3/4 (528)

NOTES:  
 1. STANDARD UNIT WEIGHT IS WITH LOW GAS HEAT AND WITHOUT PACKAGING.  
 FOR OTHER OPTIONS AND ACCESSORIES, REFER TO THE PRODUCT DATA CATALOG.  
 2. 48HC 12 SHOWN - SEE DETAIL A FOR OUTDOOR FAN VARIATIONS

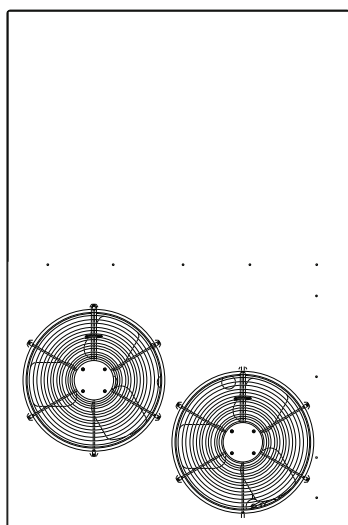

DETAIL A  
48HC 08,09

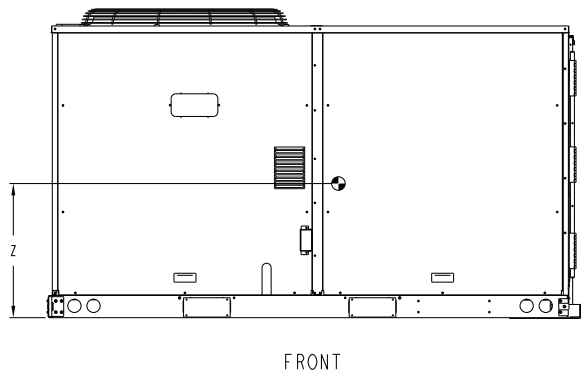
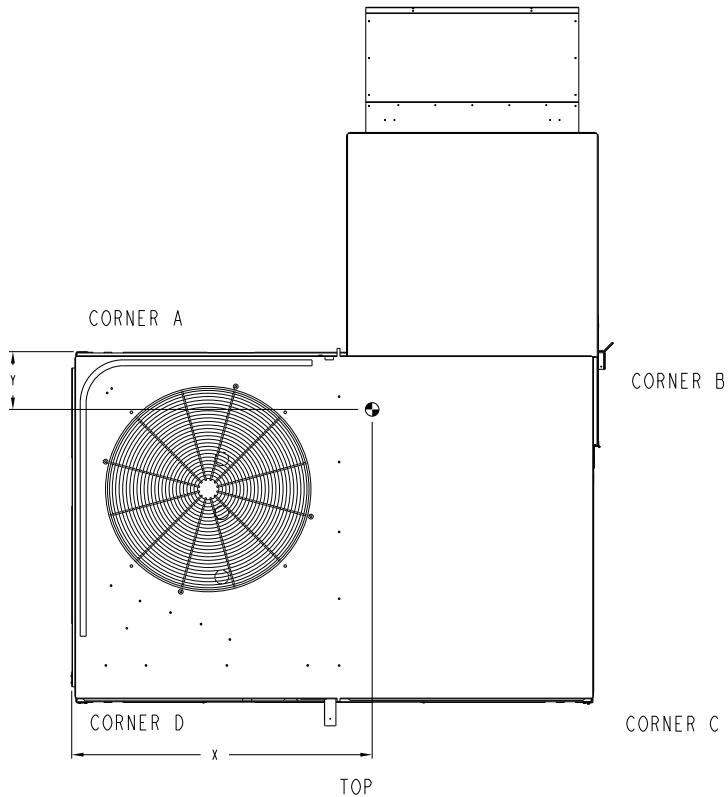

# Base unit dimensions (cont)



## SERVICE CLEARANCES — 48HC\*\*08-12 WITH ENERGYX® SYSTEM

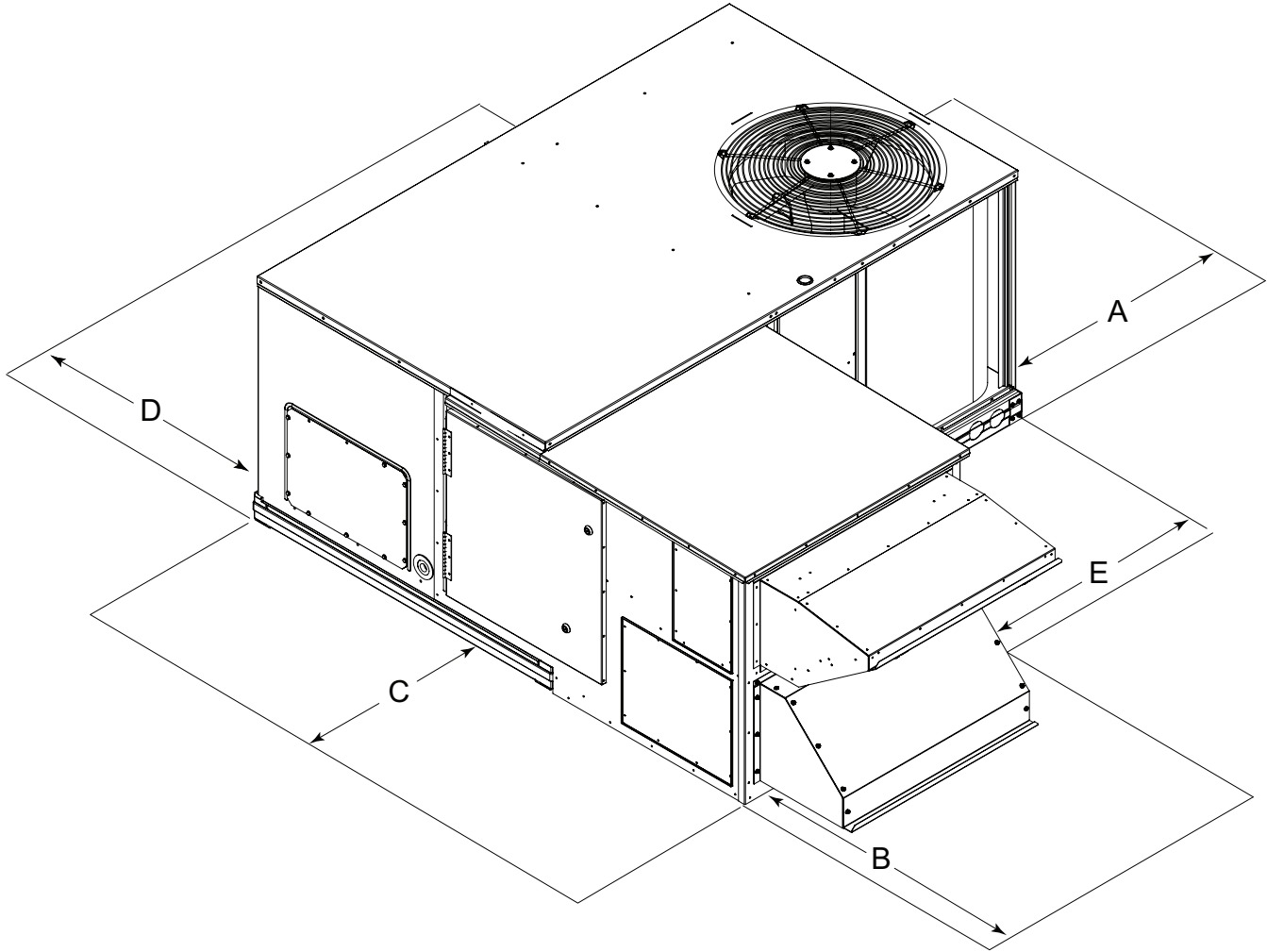

LOCATION	DIMENSION in. (mm)	CONDITION
A	48 (1219) 18 (457) 18 (457) 12 (305)	Unit disconnect is mounted on panel. No disconnect, convenience outlet option. Recommended service clearance. Minimum clearance.
B	36 (914)	Recommended service clearance.
C	36 (914)	Recommended service clearance.
D	48 (1219) 42 (1067) 36 (914) Special	No flue discharge accessory installed, surface is combustible material. Surface behind servicer is grounded (e.g., metal, masonry wall, another unit). Surface behind servicer is electrically non-conductive (e.g., wood, fiberglass). Check for adjacent units or building fresh air intakes within 10-ft (3 m) of this unit's flue outlet.
E	36 (914)	Recommended service clearance.

NOTE: Unit is not designed to have overhead obstruction. Contact Application Engineering for guidance on any application planning overhead obstruction or for vertical clearances.

# 48HC\*\* -14 WITH ENERGYX® SYSTEM UNIT DIMENSIONS

- NOTES:
1. DIMENSIONS ARE IN INCHES. DIMENSIONS IN ( ) ARE IN MILLIMETERS.
  2. CENTER OF GRAVITY
  3. DIRECTION OF AIR FLOW

CONNECTION SIZES	
B	2 1/2" - 164I DIA POWER SUPPLY HOLE
D	7/8" - 122I DIA FIELD CONTROL WIRING HOLE
E	3/4" - 14 NPT CONDENSATE DRAIN
F	7/8" - 122I DIA FIELD CONVENIENCE OUTLET HOLE
G	3/4" - 14 NPT GAS CONNECTION

THRU-THE-BASE CHART THESE HOLES REQUIRED FOR USE CHRIMP/ROUSADU, DDBKA00, D01A00			
ACCESSORY NO.	THREADED CONDUIT SIZE	WIRE USE	REQ'D HOLE SIZES (MAX.)
005	W 1/2"	ACC.	7/8" - 122.2I
	X 1/2"	24V	7/8" - 122.2I
	Y 1 1/4"	POWER	1 1/2" - 138.1I
006	Z 3/4"	PIPE	1 3/4" - 144.5I
	W 1/2"	ACC.	7/8" - 122.2I
	X 1/2"	24V	7/8" - 122.2I
007	Y 1 1/2"	POWER	2" - 150.8I
	Z 3/4"	PIPE	GAS 1 3/4" - 144.5I
	W 1/2"	ACC.	7/8" - 122.2I
	Y 1/2"	24V	7/8" - 122.2I
	Z 3/4"	PIPE	GAS 1 3/4" - 144.5I

FOR "THRU-THE-BASE" FACTORY OPTION, FITTINGS AND HOLES PROVIDED AS SPECIFIED ON "006".

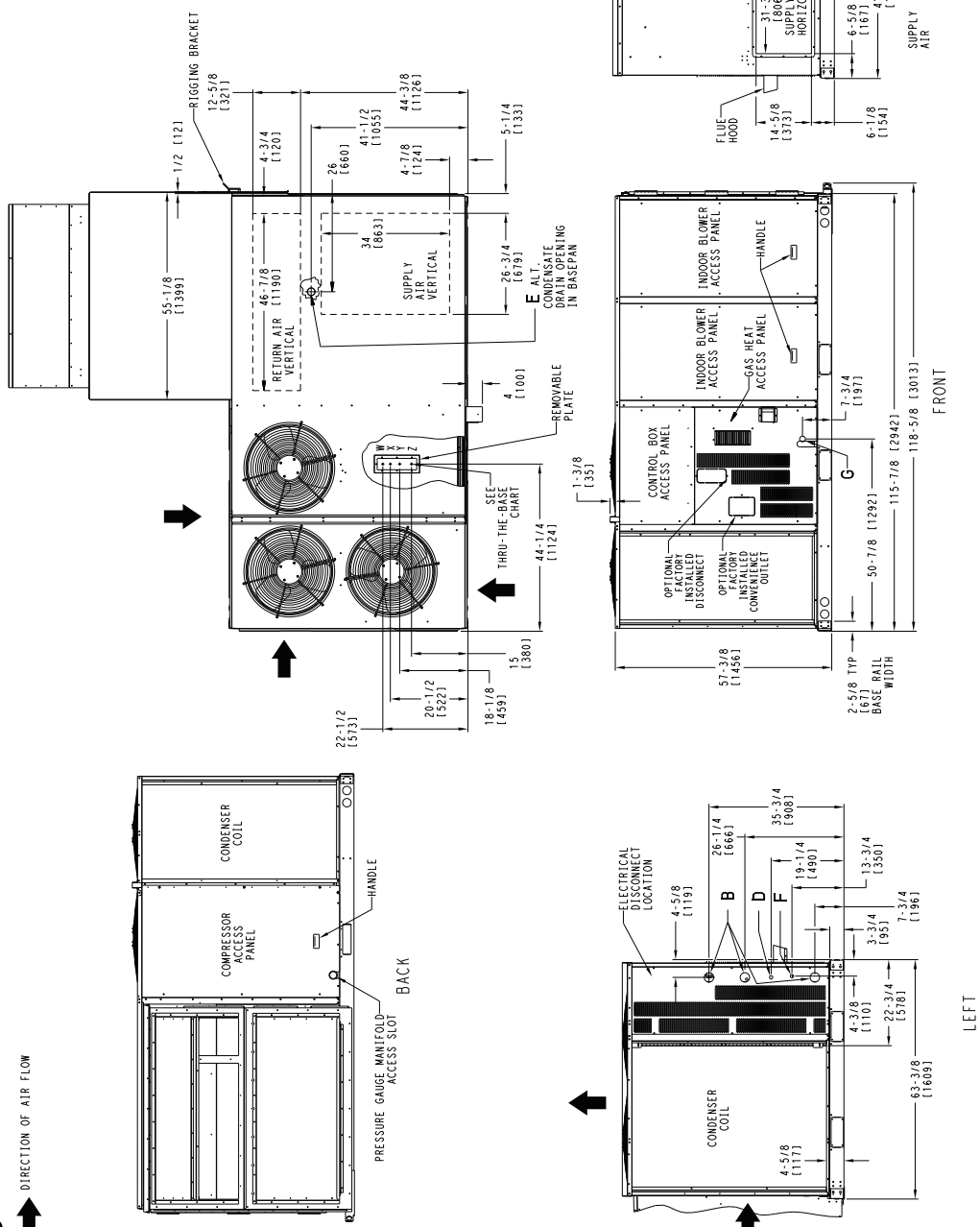

## 48HC\*\*-14 WITH ENERGYX® SYSTEM UNIT DIMENSIONS (cont)

UNIT	STD UNIT WEIGHT		CORNER WEIGHT (A)		CORNER WEIGHT (B)		CORNER WEIGHT (C)		CORNER WEIGHT (D)		C.G.		
	LBS.	KG.	LBS.	KG.	LBS.	KG.	LBS.	KG.	LBS.	KG.	X	Y	Z
48HCD 14	2585	1175	800	364	1379	627	257	117	149	68	73 3/8 (1864)	10 (253)	20 5/8 (525)

STANDARD UNIT WEIGHT IS WITH LOW HEAT & WITHOUT PACKAGING.  
FOR OPTIONS & ACCESSORIES, REFER TO THE PRODUCT DATA CATALOG.

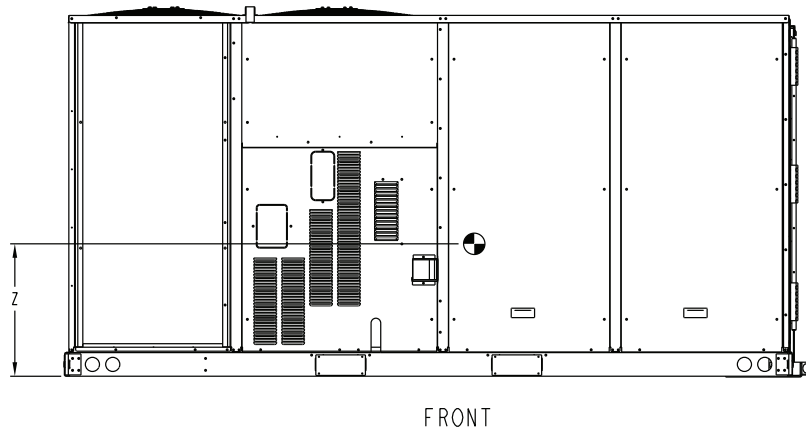
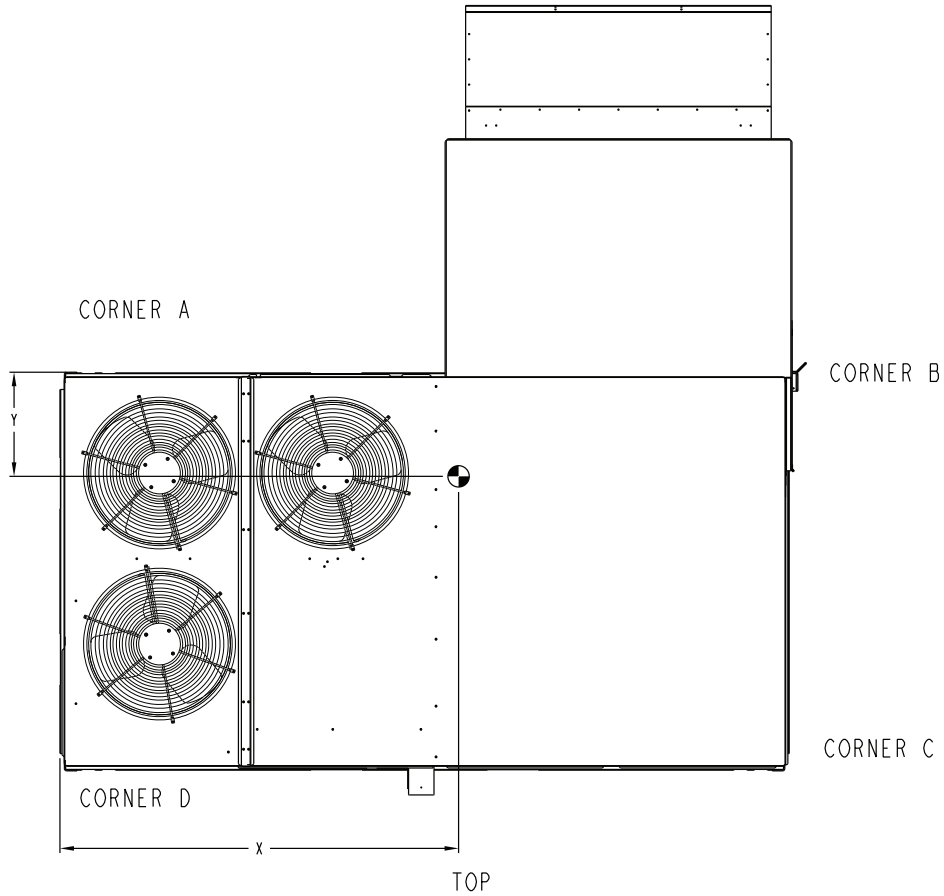

**SERVICE CLEARANCES — 48HC\*\*14 UNITS WITH ENERGYX® SYSTEM**

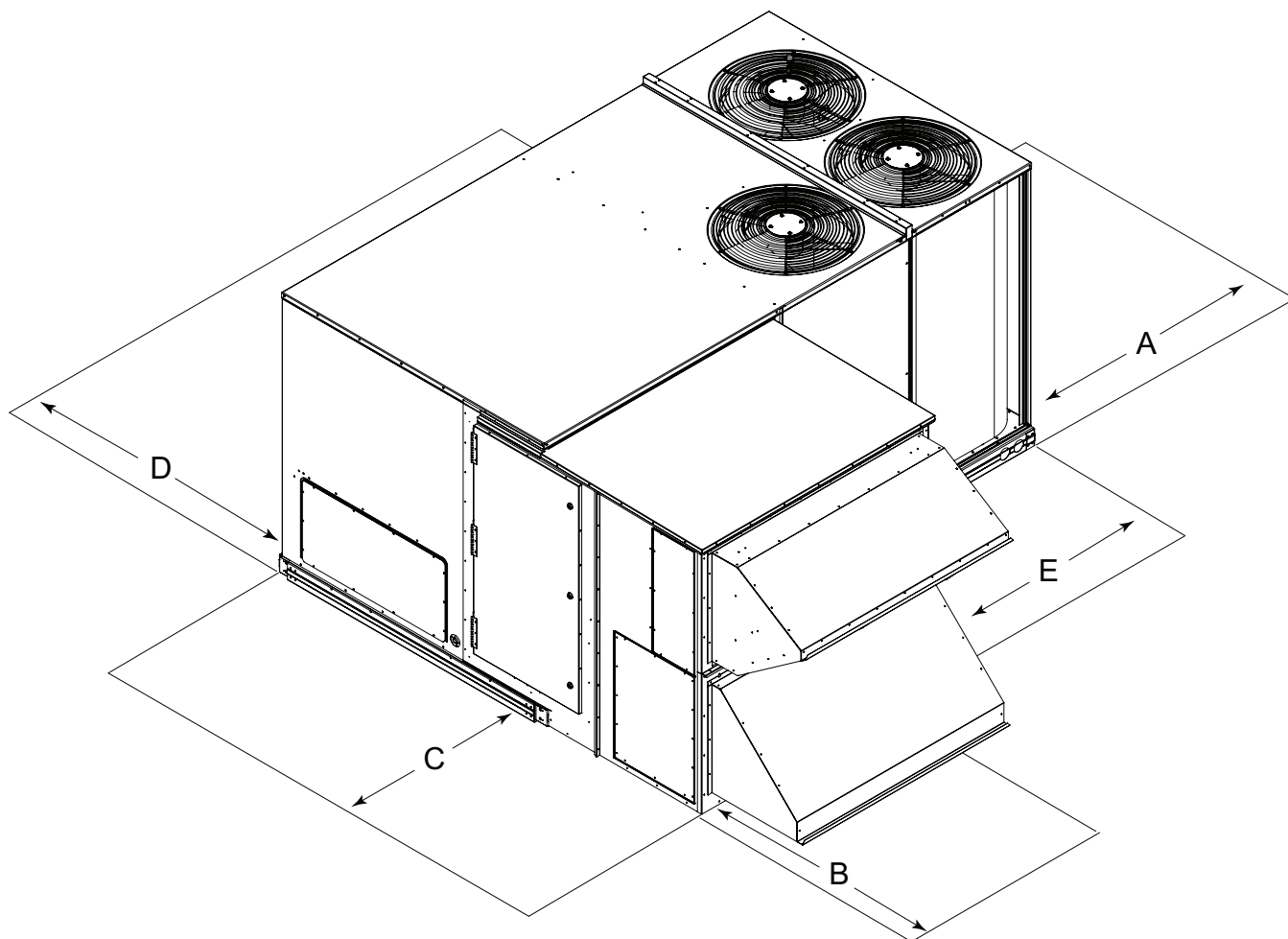

LOCATION	DIMENSION in. (mm)	CONDITION
A	48 (1219)	Unit disconnect is mounted on panel. No disconnect, convenience outlet option. Recommended service clearance. Minimum clearance.
	18 (457)	
	18 (457)	
	12 (305)	
B	36 (914)	Recommended service clearance.
C	36 (914)	Recommended service clearance.
D	48 (1219)	No flue discharge accessory installed, surface is combustible material. Surface behind servicer is grounded (e.g., metal, masonry wall, another unit). Surface behind servicer is electrically non-conductive (e.g., wood, fiberglass). Check for adjacent units or building fresh air intakes within 10-ft (3 m) of this unit's flue outlet.
	42 (1067)	
	36 (914)	
	Special	
E	36 (914)	Recommended service clearance.

NOTE: Unit not designed to have overhead obstruction. Contact Application Engineering for guidance on any application planning overhead obstruction or for vertical clearances.



## ROOF CURB DIMENSIONS — SIZE 48HC\*\*04-06

ROOF CURB ACCESSORY #	A
CRRFCURB001A01	14" [356]
CRRFCURB002A01	24" [610]

- NOTES:
1. ROOFCURB ACCESSORY IS SHIPPED DISASSEMBLED.
  2. INSULATED PANELS: 25.4 [1"] THK. POLYURETHANE FOAM, 44.5 [1-3/4]" # DENSITY.
  3. DIMENSIONS IN [ ] ARE IN MILLIMETERS.
  4. ROOFCURB: 18 GAGE STEEL.
  5. ROOFCURB: 18 GAGE STEEL. (FLANGES OF DUCT REST ON CURB).
  6. SERVICE CLEARANCE 4 FEET ON EACH SIDE.
  7. DIRECTION OF AIR FLOW.
  8. CONNECTOR PACKAGE CRRTMPWR001A01 IS FOR THRU-THE-CURB GAS TYPE PACKAGE CRRTMPWR003A01 IS FOR THRU-THE-BOTTOM TYPE GAS CONNECTIONS.

CONNECTOR PKG. ACC.	GAS CONNECTION TYPE	GAS FITTING	POWER WIRING FITTING	CONTROL WIRING FITTING	ACCESSORY CONVENIENCE OUTLET WIRING CONNECTOR
CRRTMPWR001A01	THRU THE CURB	3/4" [19] NPT	3/4" [19] NPT	1/2" [12.7] NPT	1/2" [12.7] NPT
CRRTMPWR003A01	THRU THE BOTTOM	1/2" [12.7] NPT			

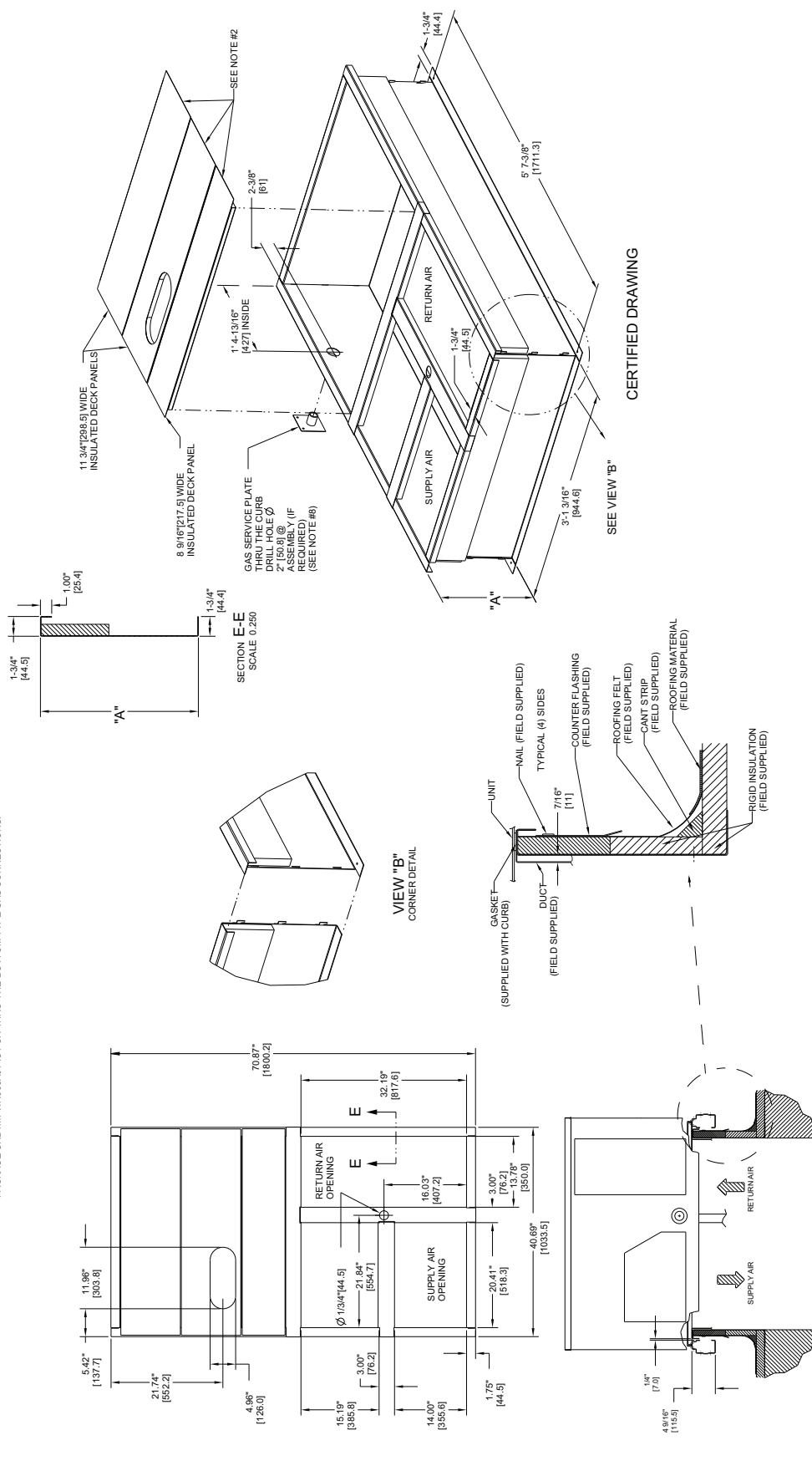



# ROOF CURB DIMENSIONS — SIZE 48HC\*\*07-12

ROOF CURB ACCESSORY #	A
CRRFCURB003A01	14" [356]
CRRFCURB004A01	24" [610]

- NOTES:  
 1. ROOF CURB ACCESSORY IS SUPPLIED DISASSEMBLED.  
 2. INSULATED PANELS: 2x4 (1 1/2" THK POLYURETHANE FOAM, 44.5 [1.34] # DENSITY.  
 3. DIMENSIONS IN [ ] ARE IN MILLIMETERS.  
 4. ROOF CURB: 18 GAGE STEEL.  
 5. ATTACH DUCTWORK TO CURB. (FLANGES OF DUCT REST ON CURB).  
 6. ATTACH CURB TO ROOFING MATERIAL WITH NAILS ON EACH SIDE.  
 7. POINTS OF CONNECTION OF AIR FLOW.  
 8. CONNECTOR PACKAGE CRBTMPWR002A01 IS FOR THRU-THE-CURB GAS TYPE PACKAGE CRBTMPWR004A01 IS FOR THRU-THE-BOTTOM TYPE GAS CONNECTIONS.

CONNECTOR PKG. ACC.	GAS CONNECTION TYPE	GAS FITTING	POWER WIRING FITTING	CONTROL WIRING FITTING	ACCESSORY CONVENIENCE OUTLET WIRING CONNECTOR
CRBTMPWR002A01	THRU THE CURB	3/4" [19] NPT	1 1/4" [31.7] NPT	1/2" [12.7] NPT	1/2" [12.7] NPT
CRBTMPWR004A01	THRU THE BOTTOM				

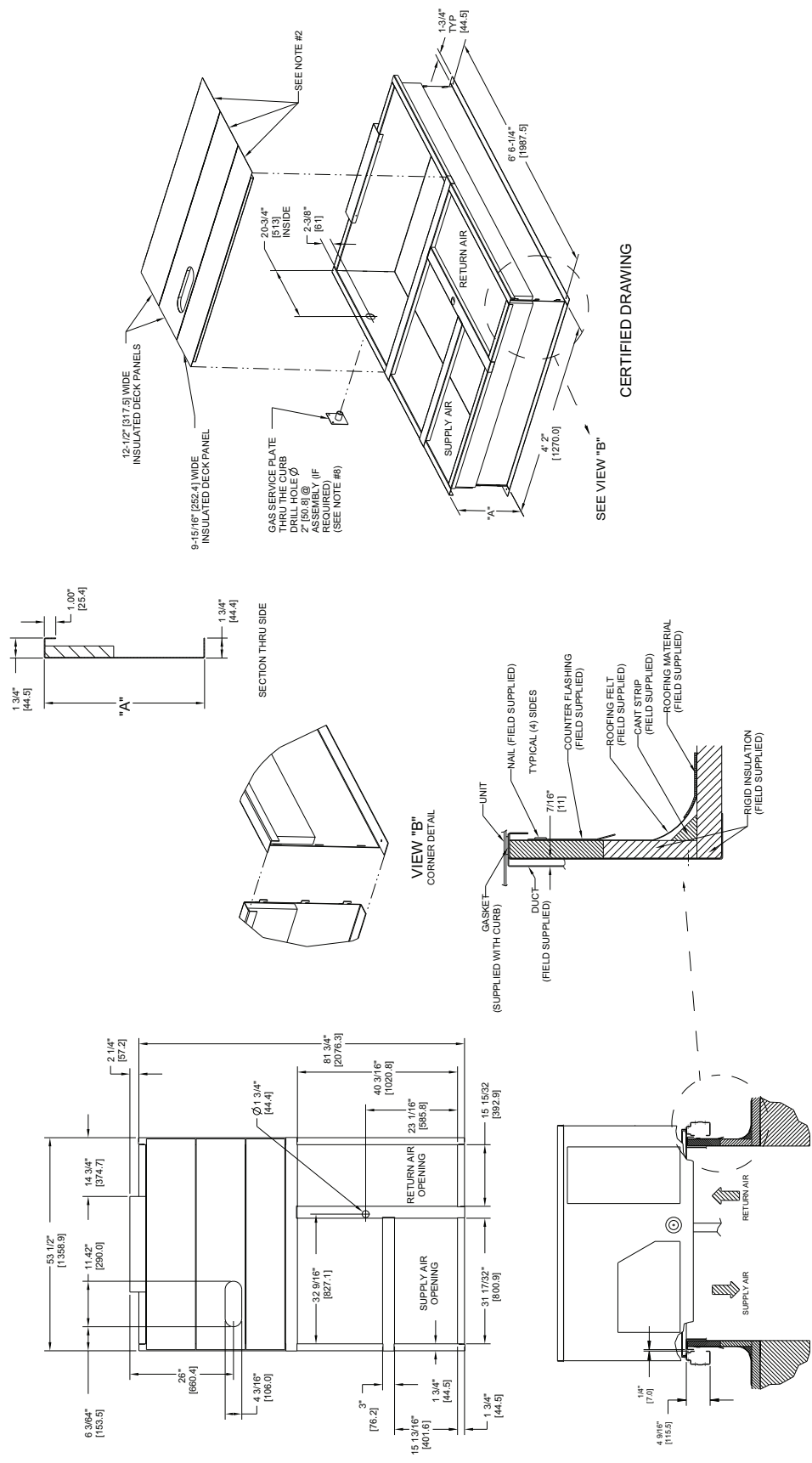

CERTIFIED DRAWING

## ROOF CURB DIMENSIONS — SIZE 48HC\*\*14

- NOTES:
1. ROOFCURB ACCESSORY IS SHIPPED DISASSEMBLED.
  2. INSULATED PANELS: 1/2" THK. NEOPRENE FOAM, 1.0# DENSITY.
  3. INSULATED PANELS: 1/2" THK. NEOPRENE FOAM, 1.0# DENSITY.
  4. ROOFCURB SIDE WALLS: 1/2" GAGE STEEL.
  5. ATTACH DUCTWORK TO CURB. (FLANGES OF DUCT REST ON CURB).
  6. SERVICE CLEARANCE 4 FT ON EACH SIDE.
  7. DIRECTION OF AIR FLOW.
  8. \*\*"L" IS THE POSITION OF LARGE DUCT OPENING CURB. (POSITION "L" FOR LARGE DUCT OPENING CURB).

ROOF CURB ACCESSORY #	A
CRRCURB074A00	14" [356]
CRRCURB075A00	24" [610]

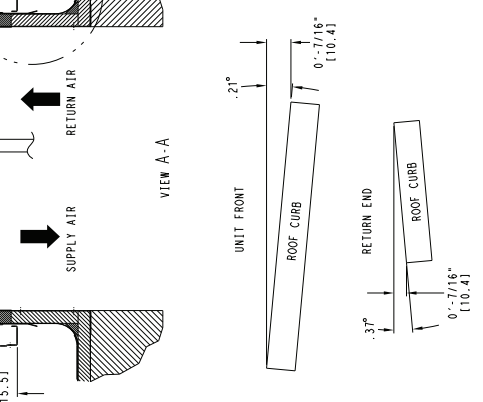
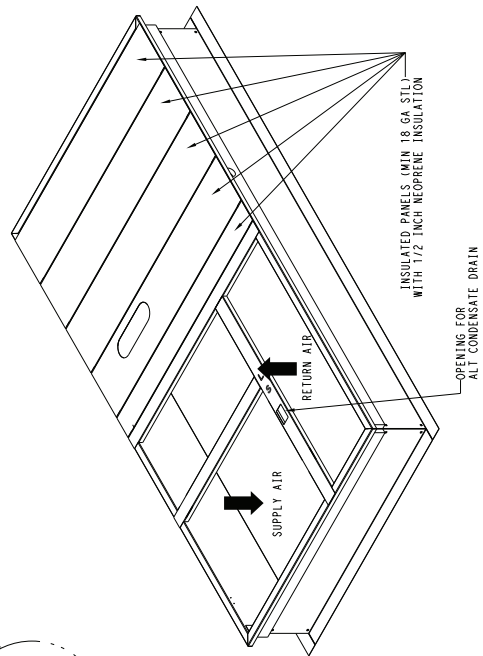
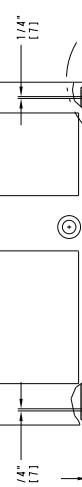
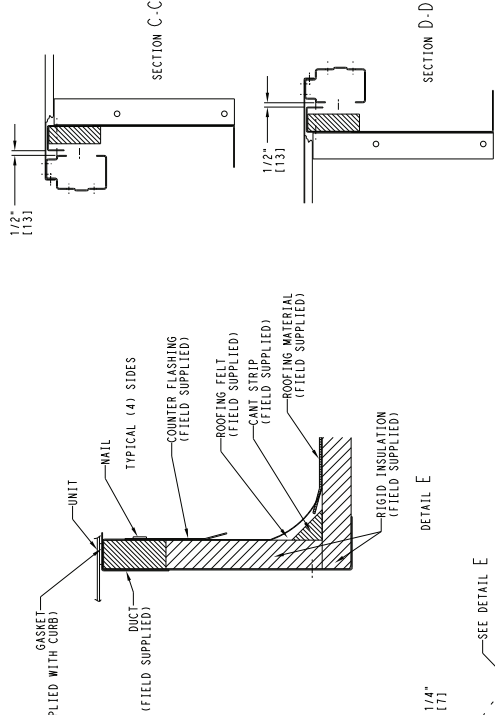
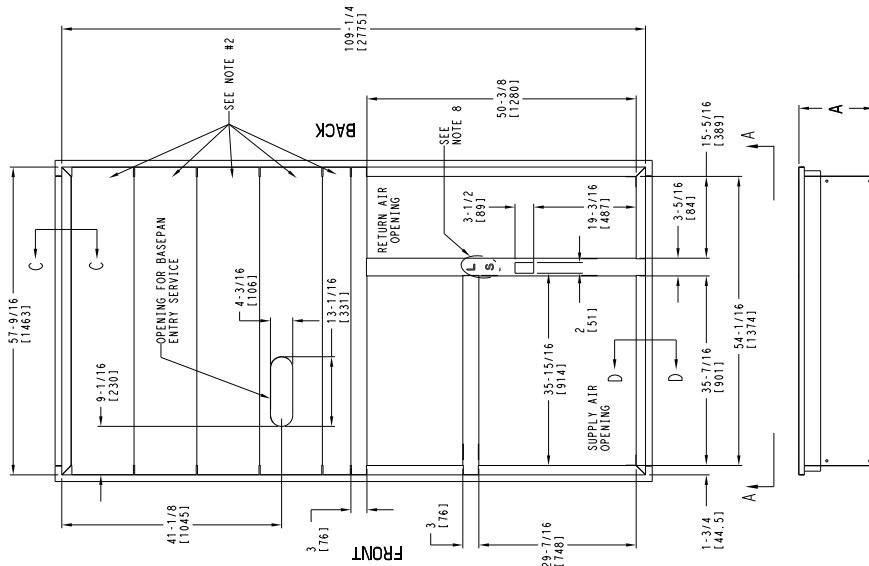

## Base Unit Selection Procedure (With 48HC\*A07 Example)

NOTE: Selection software by Carrier saves time by performing many of the steps below. Contact your Carrier sales representative for assistance.

### I Determine Heating and Cooling Loads

#### GIVEN:

Mixed air dry bulb	80°F (27°C)
Mixed air wet bulb	67°F (19°C)
Ambient dry bulb	95°F (35°C)
TC <sub>LOAD</sub> (Total Capacity Load)	72.0 MBH
SHC <sub>LOAD</sub> (Sensible Heat Capacity Load)	54.0 MBH
Vertical air supply	2100 CFM
Heating load	85.0 MBH
External static pressure	0.67 in. wg
Electrical characteristics	230-3-60

### II Make an Initial Guess at Cooling Tons:

Refrigerant tons =  
Total Capacity Load / 12 MBH per ton  
EXAMPLE: Refrigerant tons = 72 / 12 = 6 tons

### III Look up the RTU (Rooftop Unit) TC and SHC:

Page 59 shows that, at the application's supply air CFM, mixed air and ambient temperatures, the 48HC\*A07 supplies:

TC = 73.6 MBH\*  
SHC = 53.3 MBH\*

### IV Calculate the Building Latent Heat Load

LC LOAD = TC LOAD – SHC LOAD  
EXAMPLE: 72.0 MBH – 54 MBH = 18 MBH

### V Calculate RTU Latent Heat Capacity

LC = TC – SHC  
LC = 73.6 MBH – 53.3 MBH = 20.3 MBH

### VI Compare RTU Capacities to Loads†

Compare the rooftop's SHC and LC to the building's sensible and latent heat loads.

### VII Select Factory-Installed Options (FIOP)

Local code requires an economizer for any unit with TC greater than 65.0 MBH.

### VIII Calculate the Total Static Pressure

External static pressure	0.67 in. wg
Sum of FIOP / Accessory static	<u>+0.13 in. wg</u>
Total Static Pressure	0.80 in. wg

### IX Look Up the Indoor Fan RPM (Revolutions Per Minute) and BHP (Breaker Horsepower)

Page 88 shows size 07 3 phase vertical fan performance, at 2100 CFM and ESP= 0.8,  
RPM = 712 and BHP = 1.17

### X Convert BHP Into Fan Motor Heat

Fan motor heat = 2.546\* BHP/Motor Eff.\*\*  
Fan motor heat = 3.7 MBH

### XI Calculate RTU Heating Capacity

Building heating load	85.0 MBH
Fan motor heat	<u>-3.7 MBH</u>
Required heating capacity	81.3 MBH

### XII Select a Gas Heater

The heat ratings table on page 8 shows the heating capacities of the 48HCEA07. The 48HCEA07 = 103.0 MBH. Select the 48HCEA07.

### XIII Determine Electrical Requirements

MCA (Minimum Circuit Amps)/MOCP (Maximum Overcurrent Protection) tables show the MCA and Breaker Size of a 48HC\*A07 (without convenience outlet) as:

MCA = 32.0 amps and MOCP = 50.0 amps  
Min. disconnect size: FLA (Full Load Amps) = 31.0 and LRA (Lock Rotor Amp) = 148.

**EnergyX® Unit Selection Procedure** — When selecting the WeatherMaster Series Unit and EnergyX® system to use on a given application, it is strongly recommended that the Carrier Packaged RTU Builder (PRB) Selection Software be used. This is because there are a number of variables which become complex when manual calculations are performed, but can easily be accounted for in a computer operation. Most specifically, the AHRI certified ratings use Standard CFM values, but due to real world operation, variances in altitude and air density are very important. The Carrier PRB software uses altitude corrected airflows (ACFM).

If the outside air requirement is greater than 10% of a rooftop unit's supply air rating the EnergyX system should be considered to enhance the comfort of the occupants and reduce the tonnage of the rooftop unit. Carrier's Packaged RTU Builder selection software program offers a quick, simple look at the advantages and payback of the EnergyX system.

Typical Energy Recovery unit selection involves the following steps:

1. Determine the zone cooling and heating requirements at the design conditions.
2. Select Energy Recovery unit based on desired outdoor airflow rate.

\* Unit ratings are gross capacities and do not include the effect of evaporator fan motor heat. See Step XI for determining amount of evaporator fan motor heat to subtract from total and sensible capacities to obtain net cooling and net sensible capacities.

† Selecting a unit with a SHC slightly lower than the SHC LOAD is often better than oversizing. Slightly lower SHC's will help control indoor humidity, and prevent temperature swings.

\*\* Indoor fan motor efficiency available in Electrical Information Tables. Use the decimal form in the equation, eg. 80% = .8.

## Selection procedure (cont)



NOTE: It is recommended that the outdoor airflow and exhaust airflow rates be designed at the same or close to the same value. If the difference between the two airflows becomes large enough, the energy recovery unit's cooling capacity, heating capacity and overall efficiency will be negatively impacted.

3. Calculate the Energy Recovery unit's leaving air conditions and unit capacities based on the outside airflow rate, temperature (dry bulb and wet bulb) and exhaust airflow rate and temperatures (dry bulb and wet bulb) at the design temperatures and maximum ventilation rate.
4. Subtract the Energy Recovery unit's cooling and heating capacities from the design zone requirements.
5. The value that remains is the necessary design size of the rooftop unit.
6. Use the Energy Recovery unit's leaving air temperatures (dry bulb and wet bulb) as the ventilation air

temperatures entering the rooftop unit to be mixed with the return air before passing through the rooftop unit's evaporator.

7. After selecting the desired Energy Recovery unit and rooftop unit, use AHRI's Guideline V to calculate the Combined Efficiency Factor (system EER).

Additional information on Energy Recovery capacity calculations and leaving air temperature calculations can be found in the two AHRI documents below:

AHRI Guideline V — Calculating the efficiency of energy recovery ventilation and its effect on efficiency and sizing of building HVAC systems.

AHRI Standard 1060 — Performance rating of air-to-air heat exchangers for energy recovery ventilation equipment.

## 48HC\*A04 — 3 TON — SINGLE STAGE COOLING CAPACITIES

48HC*A04			AMBIENT TEMPERATURE (F)																
			85			95			105			115			125				
			EAT (db)			EAT (db)			EAT (db)			EAT (db)			EAT (db)				
			75	80	85	75	80	85	75	80	85	75	80	85	75	80	85		
900 Cfm	EAT (wb)	58	TC	32.1	32.1	36.3	30.8	30.8	34.9	29.4	29.4	33.4	28.0	28.0	31.7	26.3	26.3	29.8	
			SHC	27.8	32.1	36.3	26.7	30.8	34.9	25.5	29.4	33.4	24.2	28.0	31.7	22.8	26.3	29.8	
		62	TC	34.0	34.0	34.3	32.3	32.3	33.5	30.6	30.6	32.6	28.7	28.7	31.7	26.6	26.6	30.6	
			SHC	25.0	29.7	34.3	24.2	28.9	33.5	23.4	28.0	32.6	22.5	27.1	31.7	21.5	26.0	30.6	
		67	TC	37.3	37.3	37.3	35.5	35.5	35.5	33.6	33.6	33.6	31.5	31.5	31.5	29.2	29.2	29.2	
			SHC	20.7	25.4	30.0	20.0	24.6	29.3	19.2	23.8	28.4	18.3	22.9	27.6	17.4	22.0	26.6	
	72	TC	40.8	40.8	40.8	38.9	38.9	38.9	36.9	36.9	36.9	34.6	34.6	34.6	32.2	32.2	32.2		
		SHC	16.3	21.0	25.7	15.6	20.3	25.0	14.8	19.5	24.1	13.9	18.6	23.3	13.0	17.7	22.3		
	76	TC	—	43.9	43.9	—	41.8	41.8	—	39.6	39.6	—	37.2	37.2	—	34.6	34.6		
		SHC	—	17.4	22.4	—	16.7	21.7	—	15.9	20.8	—	15.1	19.9	—	14.2	19.0		
	1050 Cfm	EAT (wb)	58	TC	33.8	33.8	38.4	32.5	32.5	36.8	31.0	31.0	35.1	29.4	29.4	33.3	27.6	27.6	31.3
				SHC	29.3	33.8	38.4	28.1	32.5	36.8	26.9	31.0	35.1	25.5	29.4	33.3	23.9	27.6	31.3
62			TC	35.1	35.1	37.5	33.3	33.3	36.6	31.5	31.5	35.7	29.6	29.6	34.5	27.7	27.7	32.6	
			SHC	26.9	32.2	37.5	26.0	31.3	36.6	25.1	30.4	35.7	24.1	29.3	34.5	22.7	27.7	32.6	
67			TC	38.4	38.4	38.4	36.5	36.5	36.5	34.5	34.5	34.5	32.3	32.3	32.3	29.9	29.9	29.9	
			SHC	22.0	27.3	32.7	21.2	26.5	31.9	20.3	25.7	31.0	19.4	24.8	30.1	18.5	23.8	29.1	
72		TC	42.0	42.0	42.0	40.0	40.0	40.0	37.8	37.8	37.8	35.5	35.5	35.5	32.9	32.9	32.9		
		SHC	16.9	22.3	27.6	16.1	21.5	26.9	15.3	20.7	26.0	14.4	19.8	25.1	13.5	18.8	24.2		
76		TC	—	45.0	45.0	—	42.9	42.9	—	40.6	40.6	—	38.0	38.0	—	35.3	35.3		
		SHC	—	18.1	23.8	—	17.4	23.0	—	16.6	22.2	—	15.7	21.3	—	14.8	20.3		
1200 Cfm		EAT (wb)	58	TC	35.3	35.3	40.0	33.9	33.9	38.4	32.3	32.3	36.6	30.6	30.6	34.7	28.7	28.7	32.5
				SHC	30.6	35.3	40.0	29.4	33.9	38.4	28.0	32.3	36.6	26.5	30.6	34.7	24.9	28.7	32.5
	62		TC	35.9	35.9	40.5	34.2	34.2	39.4	32.4	32.4	38.1	30.6	30.6	36.1	28.7	28.7	33.9	
			SHC	28.6	34.5	40.5	27.7	33.6	39.4	26.6	32.4	38.1	25.2	30.6	36.1	23.6	28.7	33.9	
	67		TC	39.3	39.3	39.3	37.3	37.3	37.3	35.2	35.2	35.2	32.9	32.9	32.9	30.5	30.5	31.6	
			SHC	23.1	29.1	35.2	22.3	28.3	34.4	21.4	27.5	33.5	20.5	26.6	32.6	19.5	25.6	31.6	
	72	TC	42.9	42.9	42.9	40.8	40.8	40.8	38.5	38.5	38.5	36.1	36.1	36.1	33.4	33.4	33.4		
		SHC	17.3	23.4	29.5	16.6	22.6	28.7	15.7	21.8	27.9	14.8	20.9	27.0	13.9	19.9	26.0		
	76	TC	—	45.9	45.9	—	43.7	43.7	—	41.3	41.3	—	38.7	38.7	—	35.9	35.9		
		SHC	—	18.8	25.1	—	18.0	24.3	—	17.2	23.4	—	16.3	22.5	—	15.4	21.5		
	1350 Cfm	EAT (wb)	58	TC	36.6	36.6	41.5	35.1	35.1	39.7	33.4	33.4	37.9	31.6	31.6	35.8	29.6	29.6	33.6
				SHC	31.7	36.6	41.5	30.4	35.1	39.7	28.9	33.4	37.9	27.4	31.6	35.8	25.7	29.6	33.6
62			TC	36.7	36.7	43.2	35.1	35.1	41.3	33.4	33.4	39.4	31.6	31.6	37.3	29.6	29.6	34.9	
			SHC	30.2	36.7	43.2	28.8	35.1	41.3	27.5	33.4	39.4	26.0	31.6	37.3	24.4	29.6	34.9	
67			TC	39.9	39.9	39.9	37.9	37.9	37.9	35.8	35.8	35.9	33.4	33.4	34.9	30.9	30.9	33.9	
			SHC	24.2	30.9	37.6	23.4	30.1	36.8	22.5	29.2	35.9	21.6	28.3	34.9	20.6	27.2	33.9	
72		TC	43.6	43.6	43.6	41.4	41.4	41.4	39.1	39.1	39.1	36.6	36.6	36.6	33.9	33.9	33.9		
		SHC	17.8	24.5	31.3	17.0	23.7	30.5	16.1	22.9	29.6	15.2	22.0	28.7	14.3	21.0	27.7		
78		TC	—	46.7	46.7	—	44.4	44.4	—	41.9	41.9	—	39.2	39.2	—	36.3	36.3		
		SHC	—	19.4	26.3	—	18.6	25.5	—	17.8	24.6	—	16.9	23.7	—	15.9	22.7		
1500 Cfm		EAT (wb)	58	TC	37.7	37.7	42.7	36.1	36.1	40.9	34.3	34.3	38.9	32.5	32.5	36.8	30.4	30.4	34.4
				SHC	32.6	37.7	42.7	31.3	36.1	40.9	29.8	34.3	38.9	28.1	32.5	36.8	26.3	30.4	34.4
	62		TC	37.7	37.7	44.4	36.1	36.1	42.5	34.4	34.4	40.5	32.5	32.5	38.3	30.4	30.4	35.8	
			SHC	31.0	37.7	44.4	29.7	36.1	42.5	28.3	34.4	40.5	26.7	32.5	38.3	25.0	30.4	35.8	
	67		TC	40.5	40.5	40.5	38.4	38.4	39.1	36.2	36.2	38.2	33.8	33.8	37.2	31.2	31.2	36.1	
			SHC	25.2	32.6	40.0	24.4	31.7	39.1	23.5	30.8	38.2	22.5	29.9	37.2	21.5	28.8	36.1	
	72	TC	44.2	44.2	44.2	41.9	41.9	41.9	39.6	39.6	39.6	37.0	37.0	37.0	34.2	34.2	34.2		
		SHC	18.2	25.6	33.0	17.4	24.8	32.2	16.5	23.9	31.3	15.6	23.0	30.4	14.7	22.0	29.4		
	76	TC	—	47.2	47.2	—	44.9	44.9	—	42.3	42.3	—	39.6	39.6	—	36.7	36.7		
		SHC	—	19.9	27.5	—	19.1	26.7	—	18.3	25.8	—	17.4	24.9	—	16.4	23.9		

**LEGEND**

- Do Not Operate
- Cfm — Cubic Feet Per Minute (Supply Air)
- EAT (db) — Entering Air Temperature (Dry Bulb)
- EAT (wb) — Entering Air Temperature (Wet Bulb)
- SHC — Sensible Heat Capacity (1000 Btuh) Gross
- TC — Total Capacity (1000 Btuh) Gross

NOTE: See minimum-maximum airflow ratings on page 7.

## 48HC\*A04 — UNIT WITH HUMIDI-MIZER® SYSTEM IN SUBCOOLING MODE - SINGLE STAGE COOLING CAPACITIES

TEMP (F) AIR ENTERING CONDENSER (Edb)		AIR ENTERING EVAPORATOR - CFM								
		900			1200			1500		
		Air Entering Evaporator - Ewb (F)								
		72	67	62	72	67	62	72	67	62
75	TC	44.60	40.30	36.50	47.00	43.00	39.10	48.80	44.30	40.80
	SHC	19.80	24.50	29.30	22.60	29.10	35.30	25.40	33.00	40.40
	kW	2.02	1.97	1.93	1.96	2.00	2.05	2.08	2.02	1.98
85	TC	42.10	38.10	34.40	44.60	40.50	36.90	46.10	41.90	38.60
	SHC	17.50	22.50	27.40	20.40	26.80	33.20	22.90	30.80	38.20
	kW	2.28	2.23	2.19	2.22	2.26	2.31	2.33	2.28	2.24
95	TC	39.60	35.80	32.30	41.90	38.00	34.50	43.20	39.30	36.20
	SHC	15.20	20.30	25.50	17.80	24.50	31.10	20.20	28.40	35.90
	kW	2.56	2.51	2.47	2.50	2.54	2.60	2.62	2.56	2.52
105	TC	36.80	33.20	30.00	38.90	35.30	32.00	40.20	36.50	33.60
	SHC	12.70	18.10	23.40	15.10	22.00	28.80	17.50	25.80	33.60
	kW	2.88	2.83	2.79	2.82	2.86	2.91	2.93	2.88	2.84
115	TC	33.90	30.50	27.50	35.80	32.40	29.40	37.00	33.50	30.90
	SHC	10.10	15.70	21.20	12.30	19.50	26.40	14.50	23.10	30.90
	kW	3.23	3.19	3.15	3.17	3.21	3.26	3.28	3.23	3.19
125	TC	30.80	27.70	24.90	32.50	29.30	26.50	33.50	30.30	27.90
	SHC	7.30	13.10	18.90	9.40	16.70	23.90	11.40	20.30	27.90
	kW	3.62	3.59	3.56	3.57	3.60	3.65	3.66	3.62	3.59

## 48HC\*A04 — UNIT WITH HUMIDI-MIZER SYSTEM IN HOT GAS REHEAT MODE - SINGLE STAGE COOLING CAPACITIES

TEMP (F) AIR ENTERING CONDENSER (Edb)		AIR ENTERING EVAPORATOR - CFM								
		75 Dry Bulb 62.5 Wet Bulb (50% Relative Humidity)			75 Dry Bulb 64 Wet Bulb (56% Relative Humidity)			75 Dry Bulb 65.3 Wet Bulb (60% Relative Humidity)		
		Air Entering Evaporator - Ewb (F)								
		900	1200	1500	900	1200	1500	900	1200	1500
		80	TC	16.46	17.15	17.74	16.66	17.23	17.79	16.85
SHC	5.10		6.60	8.15	3.21	4.33	5.61	1.59	2.75	3.83
kW	1.94		2.01	2.02	2.04	2.13	2.15	2.12	2.14	2.16
75	TC	16.61	17.52	18.09	17.18	18.09	18.67	17.69	18.61	19.19
	SHC	5.24	6.96	8.48	3.71	5.15	6.45	2.40	3.59	4.69
	kW	1.98	2.00	2.01	1.99	2.01	2.02	2.00	2.02	2.03
70	TC	17.00	18.06	18.63	17.56	18.46	19.40	18.41	19.35	20.10
	SHC	5.62	7.47	9.00	4.08	5.50	7.16	3.09	4.31	5.58
	kW	1.96	1.94	1.96	1.97	2.00	1.94	1.91	1.94	1.92
60	TC	17.63	18.49	19.37	18.17	19.38	19.95	18.66	19.52	20.46
	SHC	6.21	7.89	9.71	4.66	6.39	7.68	3.31	4.45	5.90
	kW	1.93	1.96	1.92	1.95	1.92	1.94	1.97	2.00	1.96
50	TC	17.82	18.59	19.72	18.31	19.73	20.26	18.76	20.21	20.73
	SHC	6.40	7.99	10.05	4.79	6.71	7.97	3.40	5.11	6.16
	kW	1.98	2.03	1.94	2.01	1.94	1.97	2.03	1.96	1.99
40	TC	17.70	19.38	19.85	19.10	20.30	20.34	19.53	20.76	21.26
	SHC	6.30	8.74	10.17	5.54	7.26	8.05	4.13	5.64	6.67
	kW	2.07	1.95	1.99	1.93	1.91	2.02	1.96	1.94	1.97

### LEGEND

**Edb** — Entering Wet-Bulb  
**Ewb** — Entering Wet-Bulb  
**kW** — Compressor Motor Power Input  
**ldb** — Leaving Dry-Bulb  
**lwb** — Leaving Wet-Bulb  
**SHC** — Sensible Heat Capacity (1000 Btuh) Gross  
**TC** — Total Capacity (1000 Btuh) Gross

### NOTES:

- Direct interpolation is permissible. Do not extrapolate.
- The following formulas may be used.

$$t_{ldb} = t_{edb} - \frac{\text{sensible capacity (Btuh)}}{1.10 \times \text{cfm}}$$

$t_{lwb}$  = Wet-bulb temperature corresponding to enthalpy of air leaving evaporator coil ( $h_{lwb}$ ).

$$h_{lwb} = h_{ewb} - \frac{\text{total capacity (Btuh)}}{4.5 \times \text{cfm}}$$

Where:  $h_{ewb}$  = Enthalpy of air entering evaporator coil.



### 48HC\*A05 — SINGLE STAGE COOLING CAPACITIES

48HC*A05			AMBIENT TEMPERATURE (F)																
			85			95			105			115			125				
			EAT (db)			EAT (db)			EAT (db)			EAT (db)			EAT (db)				
			75	80	85	75	80	85	75	80	85	75	80	85	75	80	85		
1200 Cfm	EAT (wb)	58	TC	43.2	43.2	49.1	41.5	41.5	47.2	39.7	39.7	45.1	37.7	37.7	42.9	35.6	35.6	40.4	
			SHC	37.3	43.2	49.1	35.9	41.5	47.2	34.3	39.7	45.1	32.6	37.7	42.9	30.7	35.6	40.4	
		62	TC	45.9	45.9	46.0	43.7	43.7	45.0	41.3	41.3	43.8	38.8	38.8	42.6	36.0	36.0	41.2	
			SHC	33.5	39.8	46.0	32.5	38.7	45.0	31.3	37.6	43.8	30.1	36.3	42.6	28.8	35.0	41.2	
		67	TC	50.5	50.5	50.5	48.0	48.0	48.0	45.4	45.4	45.4	42.6	42.6	42.6	39.6	39.6	39.6	
			SHC	27.9	34.1	40.4	26.8	33.1	39.4	25.7	32.0	38.2	24.5	30.8	37.1	23.2	29.5	35.8	
	72	TC	55.4	55.4	55.4	52.7	52.7	52.7	49.9	49.9	49.9	46.8	46.8	46.8	43.5	43.5	43.5		
		SHC	22.0	28.4	34.7	21.0	27.3	33.7	19.9	26.2	32.5	18.7	25.0	31.3	17.4	23.8	30.1		
	76	TC	—	59.7	59.7	—	56.8	56.8	—	53.7	53.7	—	50.4	50.4	—	46.8	46.8		
		SHC	—	23.6	30.2	—	22.6	29.2	—	21.5	28.1	—	20.3	26.8	—	19.1	25.5		
	1400 Cfm	EAT (wb)	58	TC	45.6	45.6	51.9	43.8	43.8	49.8	41.9	41.9	47.6	39.7	39.7	45.1	37.3	37.3	42.4
				SHC	39.4	45.6	51.9	37.9	43.8	49.8	36.2	41.9	47.6	34.3	39.7	45.1	32.3	37.3	42.4
62			TC	47.4	47.4	50.5	45.1	45.1	49.3	42.6	42.6	48.0	40.0	40.0	46.5	37.4	37.4	44.2	
			SHC	36.0	43.2	50.5	34.9	42.1	49.3	33.7	40.9	48.0	32.4	39.5	46.5	30.6	37.4	44.2	
67			TC	52.1	52.1	52.1	49.5	49.5	49.5	46.7	46.7	46.7	43.7	43.7	43.7	40.5	40.5	40.5	
			SHC	29.5	36.8	44.0	28.4	35.7	42.9	27.3	34.5	41.8	26.0	33.3	40.5	24.7	32.0	39.2	
72		TC	57.1	57.1	57.1	54.3	54.3	54.3	51.2	51.2	51.2	48.0	48.0	48.0	44.5	44.5	44.5		
		SHC	22.8	30.1	37.4	21.7	29.0	36.3	20.5	27.8	35.1	19.3	26.6	33.9	18.0	25.3	32.6		
76		TC	—	61.4	61.4	—	58.3	58.3	—	55.1	55.1	—	51.6	51.6	—	47.8	47.8		
		SHC	—	24.6	32.2	—	23.5	31.0	—	22.4	29.9	—	21.2	28.7	—	19.9	27.4		
1600 Cfm		EAT (wb)	58	TC	47.7	47.7	54.2	45.8	45.8	52.0	43.7	43.7	49.6	41.3	41.3	47.0	38.8	38.8	44.1
				SHC	41.2	47.7	54.2	39.5	45.8	52.0	37.7	43.7	49.6	35.7	41.3	47.0	33.5	38.8	44.1
	62		TC	48.7	48.7	54.5	46.3	46.3	53.2	43.7	43.7	51.7	41.4	41.4	48.9	38.8	38.8	45.9	
			SHC	38.3	46.4	54.5	37.1	45.2	53.2	35.8	43.7	51.7	33.9	41.4	48.9	31.8	38.8	45.9	
	67		TC	53.3	53.3	53.3	50.6	50.6	50.6	47.7	47.7	47.7	44.6	44.6	44.6	41.2	41.2	42.6	
			SHC	31.0	39.2	47.5	29.9	38.1	46.3	28.7	37.0	45.2	27.5	35.7	43.9	26.2	34.4	42.6	
	72	TC	58.4	58.4	58.4	55.4	55.4	55.4	52.3	52.3	52.3	48.9	48.9	48.9	45.2	45.2	45.2		
		SHC	23.4	31.7	39.9	22.3	30.6	38.8	21.1	29.4	37.6	19.9	28.2	36.4	18.6	26.8	35.1		
	76	TC	—	62.7	62.7	—	59.5	59.5	—	56.1	56.1	—	52.5	52.5	—	48.6	48.6		
		SHC	—	25.5	34.0	—	24.4	32.9	—	23.2	31.7	—	22.0	30.4	—	20.7	29.1		
	1800 Cfm	EAT (wb)	58	TC	49.5	49.5	56.2	47.4	47.4	53.9	45.2	45.2	51.3	42.7	42.7	48.5	40.1	40.1	45.5
				SHC	42.8	49.5	56.2	41.0	47.4	53.9	39.0	45.2	51.3	36.9	42.7	48.5	34.6	40.1	45.5
62			TC	49.8	49.8	58.1	47.5	47.5	56.1	45.2	45.2	53.4	42.8	42.8	50.5	40.1	40.1	47.4	
			SHC	40.4	49.2	58.1	38.8	47.5	56.1	37.0	45.2	53.4	35.0	42.8	50.5	32.8	40.1	47.4	
67			TC	54.3	54.3	54.3	51.5	51.5	51.5	48.5	48.5	48.5	45.3	45.3	47.1	41.8	41.8	45.7	
			SHC	32.5	41.7	50.8	31.4	40.5	49.7	30.2	39.3	48.5	28.9	38.0	47.1	27.5	36.6	45.7	
72		TC	59.4	59.4	59.4	56.3	56.3	56.3	53.1	53.1	53.1	49.6	49.6	49.6	45.8	45.8	45.8		
		SHC	24.0	33.2	42.4	22.9	32.1	41.3	21.7	30.9	40.1	20.4	29.6	38.8	19.1	28.3	37.5		
78		TC	—	63.8	63.8	—	60.5	60.5	—	57.0	57.0	—	53.2	53.2	—	49.2	49.2		
		SHC	—	26.3	35.8	—	25.2	34.6	—	24.0	33.4	—	22.8	32.1	—	21.5	30.8		
2000 Cfm		EAT (wb)	58	TC	51.0	51.0	58.0	48.8	48.8	55.5	46.5	46.5	52.8	43.9	43.9	49.9	41.1	41.1	46.7
				SHC	44.1	51.0	58.0	42.2	48.8	55.5	40.2	46.5	52.8	37.9	43.9	49.9	35.5	41.1	46.7
	62		TC	51.1	51.1	60.4	48.9	48.9	57.8	46.5	46.5	55.0	44.0	44.0	51.9	41.1	41.1	48.6	
			SHC	41.8	51.1	60.4	40.0	48.9	57.8	38.1	46.5	55.0	36.0	44.0	51.9	33.7	41.1	48.6	
	67		TC	55.1	55.1	55.1	52.1	52.1	52.9	49.1	49.1	51.6	45.8	45.8	50.2	42.3	42.3	48.7	
			SHC	33.9	44.0	54.1	32.7	42.8	52.9	31.5	41.5	51.6	30.2	40.2	50.2	28.8	38.8	48.7	
	72	TC	60.3	60.3	60.3	57.1	57.1	57.1	53.7	53.7	53.7	50.1	50.1	50.1	46.3	46.3	46.3		
		SHC	24.5	34.7	44.8	23.4	33.5	43.6	22.2	32.3	42.4	21.0	31.1	41.2	19.6	29.7	39.8		
	76	TC	—	64.6	64.6	—	61.2	61.2	—	57.6	57.6	—	53.8	53.8	—	49.7	49.7		
		SHC	—	27.1	37.5	—	26.0	36.3	—	24.8	35.1	—	23.5	33.8	—	22.2	32.4		

**LEGEND**

- Do Not Operate
- Cfm — Cubic Feet Per Minute (Supply Air)
- EAT (db) — Entering Air Temperature (Dry Bulb)
- EAT (wb) — Entering Air Temperature (Wet Bulb)
- SHC — Sensible Heat Capacity (1000 Btuh) Gross
- TC — Total Capacity (1000 Btuh) Gross

NOTE: See minimum-maximum airflow ratings on page 7.

## 48HC\*A05 — UNIT WITH HUMIDI-MIZER® SYSTEM IN SUBCOOLING MODE - SINGLE STAGE COOLING CAPACITIES

TEMP (F) AIR ENTERING CONDENSER (Edb)		AIR ENTERING EVAPORATOR - CFM								
		1200			1600			2000		
		Air Entering Evaporator - Ewb (F)								
		72	67	62	72	67	62	72	67	62
75	TC	57.80	52.30	47.20	61.50	55.60	50.60	63.70	57.90	0.00
	SHC	24.20	30.50	36.80	27.90	35.90	44.00	31.20	40.90	0.00
	kW	2.50	2.47	2.44	2.46	2.48	2.51	2.53	2.50	0.00
85	TC	54.10	48.90	44.10	57.10	52.00	47.00	59.60	54.00	49.50
	SHC	20.70	27.30	33.90	23.90	32.60	41.00	27.30	37.30	47.10
	kW	2.81	2.78	2.76	2.78	2.80	2.82	2.84	2.81	2.79
95	TC	50.10	45.30	40.80	53.30	48.20	43.70	55.20	50.10	45.80
	SHC	17.00	24.00	30.90	20.40	29.10	37.70	23.30	33.60	43.60
	kW	3.16	3.14	3.12	3.13	3.15	3.18	3.19	3.16	3.14
105	TC	45.70	41.10	37.20	48.60	43.80	39.80	50.50	45.50	41.80
	SHC	12.90	20.10	27.60	16.00	25.00	34.10	19.00	29.40	39.90
	kW	3.56	3.54	3.52	3.54	3.55	3.58	3.59	3.56	3.55
115	TC	41.10	37.00	33.20	43.50	39.20	35.50	45.40	41.10	37.50
	SHC	8.70	16.40	23.90	11.30	20.70	30.10	14.30	25.40	35.80
	kW	4.02	4.01	4.00	4.00	4.01	4.03	4.04	4.03	4.01
125	TC	36.30	32.50	29.00	38.60	34.70	31.20	40.20	36.10	32.90
	SHC	4.30	12.20	20.10	6.80	16.60	26.20	9.40	20.80	31.50
	kW	4.54	4.53	4.53	4.53	4.54	4.54	4.55	4.54	4.54

## 48HC\*A05 — UNIT WITH HUMIDI-MIZER SYSTEM IN HOT GAS REHEAT MODE - SINGLE STAGE COOLING CAPACITIES

TEMP (F) AIR ENTERING CONDENSER (Edb)		AIR ENTERING EVAPORATOR - CFM								
		75 Dry Bulb 62.5 Wet Bulb (50% Relative Humidity)			75 Dry Bulb 64 Wet Bulb (56% Relative Humidity)			75 Dry Bulb 65.3 Wet Bulb (60% Relative Humidity)		
		Air Entering Evaporator - Ewb (F)								
		900	1200	1500	900	1200	1500	900	1200	1500
		80	TC	18.64	19.95	20.78	19.35	20.71	21.51	20.00
SHC	0.78		4.36	8.24	-1.95	1.01	4.29	-4.33	-1.91	0.99
kW	2.66		2.68	2.69	2.67	2.69	2.69	2.68	2.69	2.68
75	TC	19.37	21.21	22.15	20.47	21.97	22.92	21.15	22.78	23.65
	SHC	1.48	5.52	9.49	-0.91	2.18	5.57	-3.26	-0.61	2.20
	kW	2.62	2.54	2.54	2.56	2.55	2.55	2.56	2.55	2.56
70	TC	19.92	21.63	22.64	20.77	22.52	23.61	21.70	23.39	24.26
	SHC	2.01	5.94	9.98	-0.61	2.70	6.23	-2.72	-0.02	2.78
	kW	2.60	2.56	2.54	2.58	2.54	2.53	2.54	2.52	2.54
60	TC	20.11	21.27	22.23	20.75	23.15	23.43	22.49	23.78	24.55
	SHC	2.24	5.70	9.70	-0.57	3.35	6.15	-1.95	0.40	3.13
	kW	2.69	2.74	2.73	2.72	2.58	2.68	2.56	2.60	2.63
50	TC	21.56	22.70	23.37	22.18	23.33	24.01	22.75	23.90	25.40
	SHC	3.61	7.03	10.76	0.78	3.57	6.73	-1.67	0.57	3.96
	kW	2.57	2.63	2.66	2.60	2.66	2.69	2.63	2.69	2.62
40	TC	21.67	23.23	24.04	22.76	23.82	25.57	23.28	24.34	26.13
	SHC	3.74	7.56	9.89	1.35	4.06	8.17	-1.15	1.01	4.67
	kW	2.64	2.64	2.69	2.61	2.67	2.58	2.64	2.70	2.61

### LEGEND

- Edb** — Entering Wet-Bulb
- Ewb** — Entering Wet-Bulb
- kW** — Compressor Motor Power Input
- ldb** — Leaving Dry-Bulb
- lwb** — Leaving Wet-Bulb
- SHC** — Sensible Heat Capacity (1000 Btuh) Gross
- TC** — Total Capacity (1000 Btuh) Gross

### NOTES:

1. Direct interpolation is permissible. Do not extrapolate.
2. The following formulas may be used.

$$t_{ldb} = t_{edb} - \frac{\text{sensible capacity (Btuh)}}{1.10 \times \text{cfm}}$$

$t_{lwb}$  = Wet-bulb temperature corresponding to enthalpy of air leaving evaporator coil ( $h_{lwb}$ ).

$$h_{lwb} = h_{ewb} - \frac{\text{total capacity (Btuh)}}{4.5 \times \text{cfm}}$$

Where:  $h_{ewb}$  = Enthalpy of air entering evaporator coil.





## 48HC\*A06 — UNIT WITH HUMIDI-MIZER® SYSTEM IN SUBCOOLING MODE - SINGLE STAGE COOLING CAPACITIES

TEMP (F) AIR ENTERING CONDENSER (Edb)		AIR ENTERING EVAPORATOR - CFM								
		1500			2000			2500		
		Air Entering Evaporator - Ewb (F)								
		72	67	62	72	67	62	72	67	62
75	TC	66.90	60.30	54.80	71.00	64.40	58.60	73.50	66.90	61.60
	SHC	25.80	34.10	43.00	30.50	41.70	52.60	35.00	48.60	61.20
	kW	3.11	3.06	3.03	3.05	3.09	3.16	3.16	3.11	3.07
85	TC	62.40	56.50	51.20	66.30	60.10	54.70	68.20	62.30	57.50
	SHC	21.50	30.60	39.60	26.10	37.60	49.00	29.90	44.20	57.20
	kW	3.47	3.43	3.39	3.42	3.46	3.51	3.52	3.48	3.44
95	TC	57.80	52.30	47.30	61.30	55.60	50.60	63.50	57.70	53.20
	SHC	17.20	26.60	35.90	21.40	33.30	45.10	25.60	39.90	53.20
	kW	3.89	3.85	3.80	3.83	3.88	3.93	3.95	3.90	3.86
105	TC	52.80	47.50	42.90	55.40	50.00	45.30	58.00	52.20	47.90
	SHC	12.50	22.10	31.70	15.80	28.10	40.10	20.40	34.70	47.90
	kW	4.36	4.31	4.26	4.29	4.33	4.38	4.42	4.36	4.32
115	TC	47.40	42.80	38.60	50.10	45.20	41.10	51.80	47.10	43.40
	SHC	7.40	17.70	27.80	11.00	23.60	36.10	14.70	30.00	43.40
	kW	4.88	4.83	4.78	4.81	4.86	4.91	4.93	4.88	4.84
125	TC	41.60	37.50	33.80	44.00	39.70	35.80	45.80	41.30	38.00
	SHC	2.10	12.80	23.30	5.30	18.60	31.20	9.10	24.70	38.00
	kW	5.44	5.39	5.35	5.37	5.42	5.47	5.49	5.44	5.40

## 48HC\*A06 — UNIT WITH HUMIDI-MIZER SYSTEM IN HOT GAS REHEAT MODE - SINGLE STAGE COOLING CAPACITIES

TEMP (F) AIR ENTERING CONDENSER (Edb)		AIR ENTERING EVAPORATOR - CFM								
		75 Dry Bulb 62.5 Wet Bulb (50% Relative Humidity)			75 Dry Bulb 64 Wet Bulb (56% Relative Humidity)			75 Dry Bulb 65.3 Wet Bulb (60% Relative Humidity)		
		Air Entering Evaporator - Ewb (F)								
		900	1200	1500	900	1200	1500	900	1200	1500
		80	TC	25.29	27.61	28.72	26.81	28.62	29.71	27.68
SHC	5.06		10.68	15.86	2.37	6.73	11.22	-0.40	3.30	7.17
kW	3.23		3.12	3.13	3.12	3.13	3.14	3.12	3.14	3.15
75	TC	26.69	28.45	29.73	27.65	29.64	30.73	28.53	30.55	31.65
	SHC	6.39	11.52	16.85	3.20	7.72	12.20	0.43	4.29	8.16
	kW	3.08	3.11	3.09	3.10	3.09	3.11	3.11	3.10	3.12
70	TC	27.04	29.08	30.15	28.29	30.04	31.09	29.13	30.91	31.97
	SHC	6.76	12.14	17.28	3.82	8.14	12.60	1.02	4.67	8.51
	kW	3.15	3.12	3.15	3.11	3.14	3.17	3.13	3.16	3.18
60	TC	27.99	29.57	31.33	28.86	30.46	32.25	29.63	32.44	33.81
	SHC	7.70	12.66	18.45	4.41	8.60	13.74	1.54	6.16	10.28
	kW	3.17	3.23	3.15	3.21	3.26	3.18	3.23	3.12	3.10
50	TC	30.09	31.66	32.64	30.93	32.57	33.53	31.73	33.38	34.35
	SHC	9.72	14.66	19.72	6.40	10.61	14.99	3.56	7.10	10.85
	kW	3.01	3.07	3.11	3.04	3.10	3.15	3.07	3.14	3.18
40	TC	28.39	30.78	32.67	31.13	32.60	34.40	31.86	33.33	36.07
	SHC	8.17	13.89	19.80	6.63	10.69	15.85	3.72	7.10	12.51
	kW	3.39	3.32	3.24	3.14	3.23	3.15	3.18	3.27	3.08

### LEGEND

**Edb** — Entering Wet-Bulb  
**Ewb** — Entering Wet-Bulb  
**kW** — Compressor Motor Power Input  
**ldb** — Leaving Dry-Bulb  
**lwb** — Leaving Wet-Bulb  
**SHC** — Sensible Heat Capacity (1000 Btuh) Gross  
**TC** — Total Capacity (1000 Btuh) Gross

### NOTES:

1. Direct interpolation is permissible. Do not extrapolate.
2. The following formulas may be used.

$$t_{ldb} = t_{edb} - \frac{\text{sensible capacity (Btuh)}}{1.10 \times \text{cfm}}$$

$t_{lwb}$  = Wet-bulb temperature corresponding to enthalpy of air leaving evaporator coil ( $h_{lwb}$ ).

$$h_{lwb} = h_{ewb} - \frac{\text{total capacity (Btuh)}}{4.5 \times \text{cfm}}$$

Where:  $h_{ewb}$  = Enthalpy of air entering evaporator coil.



### 48HC\*A07 — SINGLE STAGE COOLING CAPACITIES

48HC*A07			AMBIENT TEMPERATURE (F)																
			85			95			105			115			125				
			EAT (db)			EAT (db)			EAT (db)			EAT (db)			EAT (db)				
			75	80	85	75	80	85	75	80	85	75	80	85	75	80	85		
1800 Cfm	EAT (wb)	58	TC	64.1	64.1	72.5	61.8	61.8	69.9	59.2	59.2	67.0	56.3	56.3	63.7	53.2	53.2	60.2	
			SHC	55.7	64.1	72.5	53.7	61.8	69.9	51.4	59.2	67.0	48.9	56.3	63.7	46.2	53.2	60.2	
		62	TC	67.9	67.9	68.5	64.9	64.9	67.0	61.5	61.5	65.3	57.9	57.9	63.5	54.0	54.0	61.4	
			SHC	50.2	59.4	68.5	48.8	57.9	67.0	47.1	56.2	65.3	45.4	54.4	63.5	43.4	52.4	61.4	
		67	TC	74.8	74.8	74.8	71.5	71.5	71.5	67.8	67.8	67.8	63.8	63.8	63.8	59.5	59.5	59.5	
			SHC	41.8	50.9	60.1	40.3	49.5	58.7	38.8	47.9	57.1	37.1	46.2	55.4	35.3	44.4	53.6	
	72	TC	82.2	82.2	82.2	78.7	78.7	78.7	74.7	74.7	74.7	70.4	70.4	70.4	65.6	65.6	65.6		
		SHC	33.0	42.3	51.6	31.6	40.9	50.2	30.1	39.3	48.6	28.4	37.7	46.9	26.7	35.9	45.1		
	76	TC	—	88.7	88.7	—	84.8	84.8	—	80.6	80.6	—	76.0	76.0	—	70.9	70.9		
		SHC	—	35.3	45.2	—	33.9	43.7	—	32.4	42.0	—	30.7	40.3	—	28.9	38.5		
	2100 Cfm	EAT (wb)	58	TC	67.6	67.6	76.5	65.1	65.1	73.7	62.3	62.3	70.5	59.3	59.3	67.1	55.9	55.9	63.2
				SHC	58.7	67.6	76.5	56.6	65.1	73.7	54.1	62.3	70.5	51.5	59.3	67.1	48.5	55.9	63.2
62			TC	70.1	70.1	74.9	67.0	67.0	73.2	63.5	63.5	71.3	59.7	59.7	69.1	56.0	56.0	65.8	
			SHC	53.9	64.4	74.9	52.4	62.8	73.2	50.6	61.0	71.3	48.7	58.9	69.1	46.2	56.0	65.8	
67			TC	77.1	77.1	77.1	73.6	73.6	73.6	69.7	69.7	69.7	65.5	65.5	65.5	60.9	60.9	60.9	
			SHC	44.2	54.8	65.3	42.7	53.3	63.9	41.2	51.7	62.3	39.4	50.0	60.5	37.6	48.1	58.6	
72		TC	84.7	84.7	84.7	80.9	80.9	80.9	76.8	76.8	76.8	72.2	72.2	72.2	67.2	67.2	67.2		
		SHC	34.2	44.8	55.5	32.7	43.4	54.0	31.1	41.8	52.4	29.5	40.1	50.7	27.6	38.2	48.8		
76		TC	—	91.3	91.3	—	87.2	87.2	—	82.7	82.7	—	77.8	77.8	—	72.5	72.5		
		SHC	—	36.7	47.8	—	35.3	46.3	—	33.7	44.7	—	32.0	43.0	—	30.2	41.1		
2400 Cfm		EAT (wb)	58	TC	70.6	70.6	79.9	68.0	68.0	76.9	65.0	65.0	73.5	61.7	61.7	69.8	58.1	58.1	65.8
				SHC	61.3	70.6	79.9	59.0	68.0	76.9	56.4	65.0	73.5	53.6	61.7	69.8	50.5	58.1	65.8
	62		TC	72.0	72.0	80.6	68.7	68.7	78.7	65.2	65.2	76.6	61.8	61.8	72.6	58.2	58.2	68.4	
			SHC	57.3	69	80.6	55.6	67.2	78.7	53.7	65.2	76.6	50.9	61.8	72.6	48.0	58.2	68.4	
	67		TC	78.9	78.9	78.9	75.2	75.2	75.2	71.2	71.2	71.2	66.8	66.8	66.8	62.0	62.0	63.4	
			SHC	46.5	58.4	70.3	45.0	56.9	68.8	43.4	55.3	67.2	41.6	53.5	65.4	39.7	51.6	63.4	
	72	TC	86.6	86.6	86.6	82.7	82.7	82.7	78.3	78.3	78.3	73.6	73.6	73.6	68.4	68.4	68.4		
		SHC	35.2	47.2	59.2	33.7	45.7	57.7	32.1	44.1	56.0	30.4	42.3	54.3	28.5	40.5	52.4		
	76	TC	—	93.3	93.3	—	89.0	89.0	—	84.4	84.4	—	79.3	79.3	—	73.7	73.7		
		SHC	—	38.0	50.4	—	36.6	48.9	—	35.0	47.3	—	33.3	45.5	—	31.4	43.6		
	2700 Cfm	EAT (wb)	58	TC	73.2	73.2	82.8	70.4	70.4	79.6	67.3	67.3	76.1	63.8	63.8	72.2	60.0	60.0	67.9
				SHC	63.6	73.2	82.8	61.1	70.4	79.6	58.4	67.3	76.1	55.4	63.8	72.2	52.1	60.0	67.9
62			TC	73.7	73.7	85.5	70.5	70.5	82.8	67.3	67.3	79.1	63.9	63.9	75.1	60.1	60.1	70.6	
			SHC	60.2	72.9	85.5	58.1	70.5	82.8	55.5	67.3	79.1	52.7	63.9	75.1	49.5	60.1	70.6	
67			TC	80.3	80.3	80.3	76.5	76.5	76.5	72.4	72.4	72.4	67.8	67.8	70.0	62.9	62.9	67.9	
			SHC	48.7	61.9	75.1	47.1	60.4	73.6	45.5	58.7	71.9	43.7	56.8	70.0	41.7	54.8	67.9	
72		TC	88.2	88.2	88.2	84.0	84.0	84.0	79.6	79.6	79.6	74.6	74.6	74.6	69.3	69.3	69.3		
		SHC	36.1	49.4	62.7	34.6	47.9	61.2	33.0	46.2	59.5	31.2	44.5	57.7	29.3	42.6	55.8		
78		TC	—	94.9	94.9	—	90.4	90.4	—	85.6	85.6	—	80.4	80.4	—	74.7	74.7		
		SHC	—	39.2	52.9	—	37.7	51.4	—	36.1	49.7	—	34.4	47.9	—	32.5	46.0		
3000 Cfm		EAT (wb)	58	TC	75.4	75.4	85.3	72.5	72.5	82.0	69.2	69.2	78.3	65.6	65.6	74.2	61.7	61.7	69.8
				SHC	65.5	75.4	85.3	62.9	72.5	82.0	60.1	69.2	78.3	57.0	65.6	74.2	53.5	61.7	69.8
	62		TC	75.5	75.5	88.7	72.5	72.5	85.3	69.3	69.3	81.4	65.7	65.7	77.2	61.7	61.7	72.5	
			SHC	62.2	75.5	88.7	59.8	72.5	85.3	57.1	69.3	81.4	54.1	65.7	77.2	50.9	61.7	72.5	
	67		TC	81.4	81.4	81.4	77.5	77.5	78.1	73.3	73.3	76.4	68.7	68.7	74.4	63.7	63.7	72.2	
			SHC	50.7	65.2	79.7	49.2	63.7	78.1	47.5	61.9	76.4	45.6	60.0	74.4	43.6	57.9	72.2	
	72	TC	89.4	89.4	89.4	85.2	85.2	85.2	80.5	80.5	80.5	75.5	75.5	75.5	70.1	70.1	70.1		
		SHC	36.9	51.5	66.1	35.4	50	64.6	33.8	48.3	62.9	32.0	46.5	61.1	30.1	44.6	59.1		
	76	TC	—	96.1	96.1	—	91.6	91.6	—	86.7	86.7	—	81.3	81.3	—	75.5	75.5		
		SHC	—	40.4	55.3	—	38.9	53.8	—	37.2	52.1	—	35.5	50.3	—	33.6	48.3		

**LEGEND**

- Do Not Operate
- Cfm — Cubic Feet Per Minute (Supply Air)
- EAT (db) — Entering Air Temperature (Dry-Bulb)
- EAT (wb) — Entering Air Temperature (Wet-Bulb)
- SHC — Sensible Heat Capacity (1000 Btuh) Gross
- TC — Total Capacity (1000 Btuh) Gross

NOTE: See minimum-maximum airflow ratings on page 7.

## 48HC\*A07 — UNIT WITH HUMIDI-MIZER® SYSTEM IN SUBCOOLING MODE - SINGLE STAGE COOLING CAPACITIES

TEMP (F) AIR ENTERING CONDENSER (Edb)		AIR ENTERING EVAPORATOR - CFM								
		1800			2400			3000		
		Air Entering Evaporator - Ewb (F)								
		72	67	62	72	67	62	72	67	62
75	TC	85.70	77.40	70.00	91.10	82.60	74.90	94.50	85.70	78.40
	SHC	38.20	47.10	56.10	43.90	55.60	67.10	49.00	63.10	76.40
	kW	4.05	4.01	3.97	4.00	4.04	4.08	4.09	4.05	4.02
85	TC	80.90	73.10	66.00	85.90	77.90	70.60	89.20	80.90	73.90
	SHC	33.50	42.90	52.30	38.80	51.10	63.00	43.90	58.60	72.10
	kW	4.46	4.43	4.39	4.42	4.45	4.48	4.51	4.47	4.43
95	TC	75.70	68.40	61.70	80.60	72.90	66.00	83.60	75.70	69.10
	SHC	28.70	38.50	48.30	33.80	46.40	58.70	38.60	53.70	67.60
	kW	4.92	4.89	4.86	4.88	4.91	4.95	4.96	4.92	4.90
105	TC	70.20	63.30	57.00	74.70	67.50	61.10	77.50	70.10	64.00
	SHC	23.60	33.90	44.10	28.40	41.40	54.20	32.90	48.60	62.70
	kW	5.43	5.40	5.37	5.39	5.42	5.45	5.47	5.43	5.41
115	TC	64.30	57.80	52.00	68.40	61.70	55.70	71.00	64.10	58.30
	SHC	18.20	28.90	39.60	22.70	36.20	49.40	27.00	43.10	58.20
	kW	5.99	5.96	5.93	5.95	5.98	6.01	6.02	5.99	5.97
125	TC	57.90	52.00	46.60	61.60	55.40	49.90	64.00	57.50	52.40
	SHC	12.40	23.80	34.90	16.60	30.70	44.30	20.70	37.30	52.40
	kW	6.59	6.57	6.55	6.56	6.59	6.61	6.62	6.60	6.58

## 48HC\*A07 — UNIT WITH HUMIDI-MIZER SYSTEM IN HOT GAS REHEAT MODE - SINGLE STAGE COOLING CAPACITIES

TEMP (F) AIR ENTERING CONDENSER (Edb)		AIR ENTERING EVAPORATOR - CFM								
		75 Dry Bulb			75 Dry Bulb			75 Dry Bulb		
		62.5 Wet Bulb			64 Wet Bulb			65.3 Wet Bulb		
		(50% Relative Humidity)			(56% Relative Humidity)			(60% Relative Humidity)		
		Air Entering Evaporator - Ewb (F)								
		1800	2400	3000	1800	2400	3000	1800	2400	3000
80	TC	24.17	25.88	26.92	25.35	27.08	28.15	26.39	28.18	29.25
	SHC	-1.44	2.99	7.86	-5.08	-1.55	2.50	-8.25	-5.47	-2.14
	kW	4.15	4.16	4.17	4.17	4.18	4.18	4.18	4.19	4.20
75	TC	26.03	27.87	28.95	27.27	29.11	30.21	28.36	30.24	31.35
	SHC	0.43	4.97	9.86	-3.12	0.49	4.56	-6.19	-3.36	-0.03
	kW	3.96	3.97	3.98	3.98	3.99	4.00	4.00	4.01	4.01
70	TC	26.50	28.76	30.07	27.92	29.99	31.34	29.45	31.67	33.23
	SHC	0.87	5.84	10.97	-2.49	1.35	5.68	-5.06	-1.85	1.94
	kW	3.97	3.93	3.91	3.96	3.95	3.93	3.92	3.89	3.87
60	TC	27.59	29.22	30.17	28.70	30.33	31.30	31.50	31.32	32.91
	SHC	1.91	6.25	11.02	-1.79	1.63	5.57	-3.31	-2.39	1.45
	kW	3.95	3.99	4.01	3.99	4.02	4.04	4.09	4.05	4.01
50	TC	27.77	29.18	30.03	28.75	30.18	32.02	29.63	32.07	32.96
	SHC	2.03	6.18	10.85	-1.80	1.43	6.25	-5.14	-1.69	1.45
	kW	4.03	4.08	4.11	4.07	4.12	4.05	4.12	4.06	4.09
40	TC	29.02	30.38	31.46	29.96	31.32	32.09	30.79	33.49	34.34
	SHC	3.26	7.34	10.07	-0.63	2.54	6.29	-4.01	-0.30	2.80
	kW	3.96	4.02	4.08	4.01	4.08	4.11	4.06	4.00	4.03

### LEGEND

**Edb** — Entering Dry-Bulb  
**Ewb** — Entering Wet-Bulb  
**kW** — Compressor Motor Power Input  
**ldb** — Leaving Dry-Bulb  
**lwb** — Leaving Wet-Bulb  
**SHC** — Sensible Heat Capacity (1000 Btuh) Gross  
**TC** — Total Capacity (1000 Btuh) Gross

### NOTES:

- Direct interpolation is permissible. Do not extrapolate.
- The following formulas may be used.

$$t_{ldb} = t_{edb} - \frac{\text{sensible capacity (Btuh)}}{1.10 \times \text{cfm}}$$

$t_{lwb}$  = Wet-bulb temperature corresponding to enthalpy of air leaving evaporator coil ( $h_{lwb}$ ).

$$h_{lwb} = h_{ewb} - \frac{\text{total capacity (Btuh)}}{4.5 \times \text{cfm}}$$

Where:  $h_{ewb}$  = Enthalpy of air entering evaporator coil.

### 48HC\*D07 — 2-STAGE COOLING CAPACITIES

48HC*D07			AMBIENT TEMPERATURE (F)															
			85			95			105			115			125			
			EAT (db)			EAT (db)			EAT (db)			EAT (db)			EAT (db)			
			75	80	85	75	80	85	75	80	85	75	80	85	75	80	85	
1800 Cfm	EAT (wb)	58	THC	64.6	64.6	72.9	62.0	62.0	70.1	59.3	59.3	67.0	56.3	56.3	63.6	53.0	53.0	60.0
			SHC	56.3	64.6	72.9	54.0	62.0	70.1	51.6	59.3	67.0	49.0	56.3	63.6	46.1	53.0	60.0
		62	THC	68.3	68.3	68.9	65.0	65.0	67.1	61.5	61.5	65.2	57.8	57.8	63.2	53.8	53.8	60.9
			SHC	50.8	59.8	68.9	49.1	58.1	67.1	47.3	56.3	65.2	45.3	54.3	63.2	43.2	52.1	60.9
		67	THC	74.8	74.8	74.8	71.2	71.2	71.2	67.4	67.4	67.4	63.4	63.4	63.4	58.9	58.9	58.9
			SHC	42.0	51.0	60.1	40.3	49.4	58.4	38.5	47.6	56.6	36.7	45.7	54.8	34.7	43.7	52.8
		72	THC	82.0	82.0	82.0	78.1	78.1	78.1	73.9	73.9	73.9	69.4	69.4	69.4	64.7	64.7	64.7
			SHC	33.0	42.1	51.3	31.3	40.5	49.6	29.6	38.7	47.9	27.7	36.8	46.0	25.8	34.9	44.0
		76	THC	—	88.0	88.0	—	83.8	83.8	—	79.4	79.4	—	74.6	74.6	—	69.4	69.4
			SHC	—	34.9	44.8	—	33.3	43.1	—	31.5	41.2	—	29.7	39.3	—	27.7	37.3
2100 Cfm	EAT (wb)	58	THC	68.1	68.1	76.8	65.3	65.3	73.7	62.3	62.3	70.3	59.1	59.1	66.7	55.6	55.6	62.8
			SHC	59.3	68.1	76.8	56.9	65.3	73.7	54.2	62.3	70.3	51.4	59.1	66.7	48.3	55.6	62.8
		62	THC	70.4	70.4	75.2	66.9	66.9	73.3	63.3	63.3	71.2	59.5	59.5	68.8	55.6	55.6	65.3
			SHC	54.5	64.9	75.2	52.7	63.0	73.3	50.8	61	71.2	48.6	58.7	68.8	45.9	55.6	65.3
		67	THC	77.1	77.1	77.1	73.2	73.2	73.2	69.2	69.2	69.2	64.9	64.9	64.9	60.3	60.3	60.3
			SHC	44.5	54.9	65.4	42.8	53.2	63.6	41.0	51.4	61.7	39.1	49.4	59.8	37.0	47.4	57.8
		72	THC	84.3	84.3	84.3	80.2	80.2	80.2	75.8	75.8	75.8	71.1	71.1	71.1	66.1	66.1	66.1
			SHC	34.1	44.6	55.2	32.4	42.9	53.4	30.6	41.1	51.6	28.8	39.2	49.6	26.8	37.2	47.6
		76	THC	—	90.4	90.4	—	86.0	86.0	—	81.3	81.3	—	76.3	76.3	—	70.9	70.9
			SHC	—	36.3	47.4	—	34.6	45.7	—	32.8	43.8	—	31.0	41.8	—	29.0	39.8
2400 Cfm	EAT (wb)	58	THC	70.9	70.9	80.0	68.0	68.0	76.7	64.8	64.8	73.1	61.4	61.4	69.3	57.7	57.7	65.2
			SHC	61.8	70.9	80.0	59.2	68.0	76.7	56.4	64.8	73.1	53.4	61.4	69.3	50.2	57.7	65.2
		62	THC	72.1	72.1	80.9	68.6	68.6	78.6	64.9	64.9	76.1	61.4	61.4	72.1	57.7	57.7	67.8
			SHC	57.9	69.4	80.9	55.9	67.3	78.6	53.7	64.9	76.1	50.8	61.4	72.1	47.7	57.7	67.8
		67	THC	78.7	78.7	78.7	74.7	74.7	74.7	70.5	70.5	70.5	66.1	66.1	66.1	61.3	61.3	62.5
			SHC	46.8	58.6	70.3	45.1	56.8	68.5	43.2	54.9	66.6	41.3	53.0	64.7	39.2	50.9	62.5
		72	THC	86.0	86.0	86.0	81.7	81.7	81.7	77.2	77.2	77.2	72.3	72.3	72.3	67.1	67.1	67.1
			SHC	35.2	47.0	58.8	33.4	45.2	57.0	31.6	43.4	55.1	29.7	41.4	53.1	27.7	39.4	51.1
		76	THC	—	92.2	92.2	—	87.6	87.6	—	82.7	82.7	—	77.5	77.5	—	72.0	72.0
			SHC	—	37.6	49.9	—	35.9	48.1	—	34.1	46.2	—	32.2	44.2	—	30.1	42.1
2700 Cfm	EAT (wb)	58	THC	73.3	73.3	82.7	70.2	70.2	79.3	66.9	66.9	75.5	63.3	63.3	71.5	59.4	59.4	67.1
			SHC	64.0	73.3	82.7	61.2	70.2	79.3	58.3	66.9	75.5	55.1	63.3	71.5	51.7	59.4	67.1
		62	THC	73.6	73.6	86.1	70.3	70.3	82.3	67.0	67.0	78.5	63.4	63.4	74.3	59.5	59.5	69.8
			SHC	61.0	73.6	86.1	58.2	70.3	82.3	55.4	67.0	78.5	52.4	63.4	74.3	49.1	59.5	69.8
		67	THC	80.0	80.0	80.0	75.9	75.9	75.9	71.6	71.6	71.6	67.0	67.0	69.3	62.1	62.1	67.0
			SHC	49.0	62.0	75.0	47.2	60.2	73.2	45.4	58.3	71.3	43.4	56.3	69.3	41.3	54.1	67.0
		72	THC	87.4	87.4	87.4	83.0	83.0	83.0	78.3	78.3	78.3	73.3	73.3	73.3	68.0	68.0	68.0
			SHC	36.1	49.2	62.2	34.3	47.4	60.4	32.5	45.5	58.5	30.6	43.5	56.5	28.5	41.4	54.3
		78	THC	—	93.6	93.6	—	88.9	88.9	—	83.9	83.9	—	78.5	78.5	—	72.8	72.8
			SHC	—	38.8	52.3	—	37.0	50.5	—	35.2	48.5	—	33.2	46.5	—	31.2	44.3
3000 Cfm	EAT (wb)	58	THC	75.6	75.6	85.2	72.2	72.2	81.5	68.7	68.7	77.6	65.0	65.0	73.4	60.9	60.9	68.8
			SHC	65.9	75.6	85.2	62.9	72.2	81.5	59.9	68.7	77.6	56.6	65.0	73.4	53.0	60.9	68.8
		62	THC	75.6	75.6	88.5	72.3	72.3	84.6	68.8	68.8	80.6	65.0	65.0	76.3	60.9	60.9	71.5
			SHC	62.7	75.6	88.5	59.9	72.3	84.6	57.0	68.8	80.6	53.8	65.0	76.3	50.4	60.9	71.5
		67	THC	81.1	81.1	81.1	76.9	76.9	77.7	72.4	72.4	75.7	67.7	67.7	73.5	62.8	62.8	71.1
			SHC	51.1	65.4	79.6	49.3	63.5	77.7	47.4	61.6	75.7	45.4	59.4	73.5	43.2	57.1	71.1
		72	THC	88.6	88.6	88.6	84.0	84.0	84.0	79.2	79.2	79.2	74.1	74.1	74.1	68.7	68.7	68.7
			SHC	37.0	51.3	65.5	35.2	49.4	63.7	33.3	47.5	61.7	31.4	45.5	59.7	29.3	43.4	57.5
		76	THC	—	94.8	94.8	—	89.9	89.9	—	84.8	84.8	—	79.3	79.3	—	73.5	73.5
			SHC	—	39.9	54.6	—	38.1	52.7	—	36.2	50.8	—	34.3	48.7	—	32.2	46.5

**LEGEND**

- Do Not Operate
- Cfm** — Cubic Feet Per Minute (Supply Air)
- EAT (db)** — Entering Air Temperature (Dry-Bulb)
- EAT (wb)** — Entering Air Temperature (Wet-Bulb)
- SHC** — Sensible Heat Capacity (1000 Btuh) Gross
- THC** — Total Heat Capacity (1000 Btuh) Gross

NOTE: See minimum-maximum airflow ratings on page 7.

## 48HC\*D07 — UNIT WITH HUMIDI-MIZER® SYSTEM IN SUBCOOLING MODE - 2-STAGE COOLING CAPACITIES

TEMP (F) AIR ENTERING CONDENSER (Edb)		AIR ENTERING EVAPORATOR - CFM								
		1800			2400			3000		
		Air Entering Evaporator - Ewb (F)								
		72	67	62	72	67	62	72	67	62
75	TC	83.50	75.60	68.50	88.50	76.00	72.90	91.70	83.40	76.20
	SHC	37.00	47.00	55.40	43.60	51.90	65.60	47.90	62.00	74.20
	kW	3.49	3.50	3.45	3.57	3.53	3.48	3.58	3.56	3.50
85	TC	79.00	71.50	64.70	83.60	75.50	68.70	86.40	78.50	71.80
	SHC	32.90	43.20	51.90	39.50	50.60	61.70	43.70	57.30	70.10
	kW	3.94	3.94	3.90	4.03	3.97	3.91	4.08	3.97	3.95
95	TC	73.50	67.10	60.70	70.20	71.20	64.60	81.30	73.70	67.10
	SHC	26.60	39.30	48.20	31.50	46.70	57.90	39.50	53.30	65.60
	kW	4.39	4.44	4.40	4.54	4.48	4.43	4.56	4.50	4.44
105	TC	68.60	62.60	56.50	73.30	66.30	60.10	75.70	68.40	62.60
	SHC	25.50	35.30	44.40	30.50	42.30	53.80	34.60	48.60	61.50
	kW	5.05	5.02	4.98	5.10	5.05	5.00	4.56	5.06	5.02
115	TC	64.20	57.80	55.00	67.80	61.20	55.30	75.70	63.20	57.60
	SHC	21.70	31.10	40.50	25.80	37.80	49.50	34.60	44.00	57.60
	kW	5.05	5.68	5.64	5.74	5.70	5.66	5.12	5.72	5.67
125	TC	58.80	52.80	47.40	62.10	55.80	50.30	63.60	57.60	52.40
	SHC	17.10	26.70	36.30	20.80	33.00	45.00	24.10	39.10	52.40
	kW	6.46	6.43	6.41	6.48	6.44	6.41	6.48	6.45	6.42

## 48HC\*D07 — UNIT WITH HUMIDI-MIZER SYSTEM IN HOT GAS REHEAT MODE - 2-STAGE COOLING CAPACITIES

TEMP (F) AIR ENTERING CONDENSER (Edb)		AIR ENTERING EVAPORATOR - CFM								
		75 Dry Bulb 62.5 Wet Bulb (50% Relative Humidity)			75 Dry Bulb 64 Wet Bulb (56% Relative Humidity)			75 Dry Bulb 65.3 Wet Bulb (60% Relative Humidity)		
		Air Entering Evaporator - Ewb (F)								
		1800	2400	3000	1800	2400	3000	1800	2400	3000
		80	TC	27.93	28.67	29.02	28.32	29.87	30.25	29.63
SHC	6.95		10.60	14.71	2.87	6.41	9.76	0.19	2.12	5.43
kW	3.80		3.79	3.78	3.79	3.78	3.78	3.79	3.78	3.77
75	TC	28.78	30.12	30.68	29.82	30.63	31.42	30.45	31.77	32.14
	SHC	7.76	12.01	16.31	4.30	7.17	10.89	1.00	3.59	6.24
	kW	3.80	3.79	3.78	3.79	3.78	3.78	3.79	3.78	3.77
70	TC	29.64	30.80	31.85	30.48	31.97	32.67	31.55	32.79	33.12
	SHC	8.60	12.69	17.46	4.95	8.46	12.12	2.06	4.59	7.21
	kW	3.80	3.79	3.78	3.79	3.78	3.78	3.79	3.78	3.77
60	TC	31.14	32.55	33.57	32.03	33.49	34.38	32.98	34.50	35.39
	SHC	10.05	14.38	19.13	6.45	9.96	13.79	3.45	6.26	9.41
	kW	3.80	3.79	3.78	3.79	3.78	3.78	3.79	3.78	3.77
50	TC	32.23	33.83	34.70	33.47	34.97	35.86	34.42	35.95	36.90
	SHC	11.11	15.63	20.24	7.83	11.39	15.24	4.84	7.67	10.88
	kW	3.80	3.79	3.78	3.79	3.78	3.78	3.79	3.78	3.77
40	TC	33.41	35.02	35.91	34.52	36.20	37.25	35.66	37.22	38.32
	SHC	12.24	16.78	21.43	8.85	12.58	16.58	6.03	8.90	12.27
	kW	3.80	3.79	3.78	3.79	3.78	3.78	3.79	3.78	3.77

### LEGEND

- Edb — Entering Wet-Bulb
- Ewb — Entering Wet-Bulb
- kW — Compressor Motor Power Input
- ldb — Leaving Dry-Bulb
- lwb — Leaving Wet-Bulb
- SHC — Sensible Heat Capacity (1000 Btuh) Gross
- TC — Total Capacity (1000 Btuh) Gross

### NOTES:

1. Direct interpolation is permissible. Do not extrapolate.
2. The following formulas may be used.

$$t_{ldb} = t_{edb} - \frac{\text{sensible capacity (Btuh)}}{1.10 \times \text{cfm}}$$

$t_{lwb}$  = Wet-bulb temperature corresponding to enthalpy of air leaving evaporator coil ( $h_{lwb}$ ).

$$h_{lwb} = h_{ewb} - \frac{\text{total capacity (Btuh)}}{4.5 \times \text{cfm}}$$

Where:  $h_{ewb}$  = Enthalpy of air entering evaporator coil.



## 48HC\*D08 — UNIT WITH HUMIDI-MIZER® SYSTEM IN SUBCOOLING MODE - 2-STAGE COOLING CAPACITIES

TEMP (F) AIR ENTERING CONDENSER (Edb)		AIR ENTERING EVAPORATOR - CFM								
		2250			3000			3750		
		Air Entering Evaporator - Ewb (F)								
		72	67	62	72	67	62	72	67	62
75	TC	101.90	92.90	84.00	109.60	96.30	89.90	113.60	103.00	94.50
	SHC	43.90	54.60	66.70	50.20	62.70	80.90	56.80	75.80	93.00
	kW	4.60	4.54	4.48	4.65	4.50	4.52	4.68	4.60	4.55
85	TC	96.60	87.30	78.90	102.80	92.90	84.50	106.50	96.70	88.70
	SHC	36.80	49.30	61.90	43.80	59.70	75.90	50.20	69.80	87.40
	kW	5.15	5.09	5.04	5.20	5.13	5.08	5.22	5.16	5.11
95	TC	90.20	81.40	73.50	95.70	86.80	78.80	99.40	90.10	82.70
	SHC	30.80	43.90	56.90	37.20	54.10	70.50	43.60	63.80	81.60
	kW	5.78	5.72	5.67	5.82	5.76	5.71	5.85	5.79	5.74
105	TC	83.50	75.20	67.80	88.80	80.20	72.70	92.00	83.20	76.40
	SHC	24.60	38.20	51.70	30.80	48.00	64.90	36.70	57.40	75.50
	kW	6.50	6.45	6.40	6.54	6.48	6.43	6.57	6.50	6.46
115	TC	76.30	68.70	61.80	81.10	73.20	66.30	84.10	76.00	69.70
	SHC	17.90	32.10	46.20	23.70	41.50	59.00	29.40	50.70	69.00
	kW	7.32	7.28	7.24	7.35	7.31	7.27	7.38	7.32	7.29
125	TC	68.60	61.60	55.40	73.00	65.70	59.30	75.80	68.20	62.60
	SHC	10.90	25.60	40.30	16.20	34.70	52.60	21.70	43.60	62.10
	kW	8.24	8.22	8.20	8.27	8.23	8.21	8.29	8.25	8.22

## 48HC\*D08 — UNIT WITH HUMIDI-MIZER SYSTEM IN HOT GAS REHEAT MODE - 2-STAGE COOLING CAPACITIES

TEMP (F) AIR ENTERING CONDENSER (Edb)		AIR ENTERING EVAPORATOR - CFM								
		75 Dry Bulb 62.5 Wet Bulb (50% Relative Humidity)			75 Dry Bulb 64 Wet Bulb (56% Relative Humidity)			75 Dry Bulb 65.3 Wet Bulb (60% Relative Humidity)		
		Air Entering Evaporator - Ewb (F)								
		2250	3000	3750	2250	3000	3750	2250	3000	3750
		80	TC	24.06	26.14	27.48	25.50	27.56	28.78	26.59
SHC	-5.55		1.16	8.38	-10.20	-4.69	1.40	-14.39	-9.85	-4.68
kW	4.43		4.42	4.41	4.40	4.41	4.42	4.42	4.43	4.44
75	TC	24.87	27.26	28.47	26.06	28.53	30.02	27.67	29.77	31.02
	SHC	-4.77	2.23	9.32	-9.65	-3.76	2.59	-13.35	-8.83	-3.66
	kW	4.42	4.36	4.38	4.45	4.38	4.36	4.36	4.39	4.40
70	TC	25.16	27.88	28.56	26.72	29.10	30.26	28.17	30.20	31.83
	SHC	-4.48	2.84	9.45	-9.02	-3.19	2.85	-12.88	-8.40	-2.87
	kW	4.49	4.38	4.48	4.44	4.41	4.44	4.40	4.44	4.40
60	TC	26.43	28.14	29.14	27.49	29.24	30.27	28.50	30.24	32.33
	SHC	-3.25	3.14	10.05	-8.26	-2.99	2.94	-12.54	-8.29	-2.32
	kW	4.48	4.55	4.59	4.53	4.60	4.65	4.58	4.65	4.54
50	TC	27.19	29.55	31.26	28.94	30.59	32.36	30.54	31.54	32.52
	SHC	-2.50	4.50	12.05	-6.87	-1.69	4.92	-10.60	-7.02	-2.07
	kW	4.53	4.51	4.46	4.48	4.57	4.52	4.43	4.63	4.70
40	TC	27.92	31.58	32.82	28.81	32.60	33.54	31.82	33.50	34.44
	SHC	-1.79	6.42	10.84	-6.94	0.23	6.05	-9.36	-5.15	-0.25
	kW	4.57	4.37	4.46	4.65	4.45	4.51	4.40	4.51	4.58

### LEGEND

- Edb** — Entering Wet-Bulb
- Ewb** — Entering Wet-Bulb
- kW** — Compressor Motor Power Input
- ldb** — Leaving Dry-Bulb
- lwb** — Leaving Wet-Bulb
- SHC** — Sensible Heat Capacity (1000 Btuh) Gross
- TC** — Total Capacity (1000 Btuh) Gross

### NOTES:

1. Direct interpolation is permissible. Do not extrapolate.
2. The following formulas may be used.

$$t_{ldb} = t_{edb} - \frac{\text{sensible capacity (Btuh)}}{1.10 \times \text{cfm}}$$

$t_{lwb}$  = Wet-bulb temperature corresponding to enthalpy of air leaving evaporator coil ( $h_{lwb}$ ).

$$h_{lwb} = h_{ewb} - \frac{\text{total capacity (Btuh)}}{4.5 \times \text{cfm}}$$

Where:  $h_{ewb}$  = Enthalpy of air entering evaporator coil.





## 48HC\*D09 — UNIT WITH HUMIDI-MIZER® SYSTEM IN SUBCOOLING MODE - 2-STAGE COOLING CAPACITIES

TEMP (F) AIR ENTERING CONDENSER (Edb)		AIR ENTERING EVAPORATOR - CFM								
		2550			3400			4250		
		Air Entering Evaporator - Ewb (F)								
		72	67	62	72	67	62	72	67	62
75	TC	114.70	103.90	93.90	104.30	110.60	100.50	122.90	114.60	105.50
	SHC	48.70	62.20	75.70	84.70	74.20	91.40	60.60	85.10	103.90
	kW	5.17	5.09	5.01	5.10	5.14	5.07	5.20	5.18	5.11
85	TC	107.80	97.40	88.00	114.20	102.90	94.20	116.20	107.60	98.70
	SHC	42.30	56.30	70.30	49.70	67.00	85.60	61.10	78.70	97.30
	kW	5.79	5.71	5.63	5.85	5.75	5.69	5.88	5.80	5.72
95	TC	100.50	90.80	82.00	106.60	96.20	87.70	110.20	100.10	92.20
	SHC	35.60	50.20	64.80	42.80	61.00	79.60	49.20	71.90	91.00
	kW	6.50	6.42	6.34	6.56	6.46	6.40	6.59	6.50	6.44
105	TC	92.70	83.80	75.70	98.50	89.00	80.90	102.10	92.40	85.10
	SHC	28.50	43.90	59.10	35.40	54.60	73.40	41.90	64.90	84.20
	kW	7.30	7.23	7.16	7.36	7.28	7.21	7.40	7.31	7.25
115	TC	85.00	76.50	69.00	90.00	81.30	73.80	93.30	84.40	77.70
	SHC	21.50	37.40	53.10	27.70	47.60	66.90	34.00	57.70	77.00
	kW	8.23	8.16	8.10	8.27	8.20	8.14	8.31	8.23	8.18
125	TC	76.50	68.80	61.80	81.10	72.90	66.20	84.10	75.80	69.80
	SHC	13.80	30.40	46.70	19.70	40.00	60.10	25.60	50.00	69.80
	kW	9.25	9.20	9.16	9.28	9.22	9.19	9.31	9.25	9.21

## 48HC\*D09 — UNIT WITH HUMIDI-MIZER SYSTEM IN HOT GAS REHEAT MODE - 2-STAGE COOLING CAPACITIES

TEMP (F) AIR ENTERING CONDENSER (Edb)		AIR ENTERING EVAPORATOR - CFM								
		75 Dry Bulb 62.5 Wet Bulb (50% Relative Humidity)			75 Dry Bulb 64 Wet Bulb (56% Relative Humidity)			75 Dry Bulb 65.3 Wet Bulb (60% Relative Humidity)		
		Air Entering Evaporator - Ewb (F)								
		2550	3400	4250	2550	3400	4250	2550	3400	4250
		80	TC	27.53	29.56	30.72	28.95	31.03	32.22	30.26
SHC	-3.84		3.82	11.92	-9.25	-2.92	4.09	-13.93	-8.77	-2.82
kW	5.09		5.11	5.13	5.11	5.14	5.15	5.14	5.15	5.17
75	TC	29.09	31.60	32.81	30.77	33.10	34.33	32.30	34.45	35.73
	SHC	-2.34	5.72	13.84	-7.51	-0.98	6.04	-11.95	-6.78	-0.82
	kW	4.97	4.91	4.93	4.95	4.94	4.95	4.94	4.96	4.97
70	TC	29.58	32.45	33.63	31.48	34.12	35.55	33.12	35.65	37.38
	SHC	-1.88	6.54	14.63	-6.83	0.00	7.20	-11.16	-5.63	0.75
	kW	4.99	4.90	4.92	4.96	4.90	4.89	4.93	4.90	4.86
60	TC	30.71	33.44	34.52	32.90	34.79	35.86	34.07	36.02	37.09
	SHC	-0.78	7.52	15.54	-5.47	0.68	7.57	-10.28	-5.24	0.55
	kW	5.03	4.95	5.00	4.94	5.01	5.05	4.99	5.06	5.09
50	TC	32.63	34.31	35.26	33.81	35.53	36.51	34.90	36.66	37.65
	SHC	1.05	8.38	16.29	-4.60	1.42	8.24	-9.49	-4.59	1.14
	kW	4.92	5.01	5.06	4.99	5.07	5.13	5.05	5.14	5.19
40	TC	31.94	33.26	35.77	32.96	35.70	37.86	35.17	38.01	38.92
	SHC	0.45	7.47	13.75	-5.35	1.63	9.52	-9.20	-3.29	2.36
	kW	5.16	5.27	5.20	5.25	5.19	5.10	5.16	5.11	5.17

### LEGEND

- Edb** — Entering Wet-Bulb
- Ewb** — Entering Wet-Bulb
- kW** — Compressor Motor Power Input
- ldb** — Leaving Dry-Bulb
- lwb** — Leaving Wet-Bulb
- SHC** — Sensible Heat Capacity (1000 Btuh) Gross
- TC** — Total Capacity (1000 Btuh) Gross

### NOTES:

1. Direct interpolation is permissible. Do not extrapolate.
2. The following formulas may be used.

$$t_{ldb} = t_{edb} - \frac{\text{sensible capacity (Btuh)}}{1.10 \times \text{cfm}}$$

$t_{lwb}$  = Wet-bulb temperature corresponding to enthalpy of air leaving evaporator coil ( $h_{lwb}$ ).

$$h_{lwb} = h_{ewb} - \frac{\text{total capacity (Btuh)}}{4.5 \times \text{cfm}}$$

Where:  $h_{ewb}$  = Enthalpy of air entering evaporator coil.



## 48HC\*D11 — UNIT WITH HUMIDI-MIZER® SYSTEM IN SUBCOOLING MODE - 2-STAGE COOLING CAPACITIES

TEMP (F) AIR ENTERING CONDENSER (Edb)		AIR ENTERING EVAPORATOR - CFM								
		3000			4000			5000		
		Air Entering Evaporator - Ewb (F)								
		72	67	62	72	67	62	72	67	62
75	TC	121.34	110.46	99.60	139.20	125.18	111.17	157.20	140.10	110.50
	SHC	58.86	72.03	85.20	67.31	80.25	93.18	74.00	86.80	72.00
	kW	6.61	6.54	6.45	6.65	6.58	6.50	6.67	6.62	6.53
85	TC	115.30	105.01	94.73	128.03	114.90	101.77	140.90	124.90	105.00
	SHC	45.81	62.19	78.57	55.02	71.16	87.29	62.30	78.30	62.20
	kW	6.76	6.88	6.78	6.80	6.73	6.83	6.82	6.77	6.87
95	TC	109.26	99.57	89.89	116.87	104.62	92.38	124.60	109.70	99.60
	SHC	32.76	52.35	71.93	42.70	62.07	81.40	50.60	69.80	52.30
	kW	7.55	7.49	7.39	7.58	7.51	7.45	7.60	7.56	7.49
105	TC	103.21	94.13	85.04	105.71	94.34	82.98	108.20	94.60	94.10
	SHC	19.71	42.51	65.30	30.45	52.98	75.51	39.00	61.30	42.50
	kW	8.47	8.42	8.32	8.51	8.44	8.37	8.53	8.49	8.41
115	TC	97.17	88.68	80.20	94.54	84.06	73.58	91.90	79.40	88.70
	SHC	6.67	32.66	58.66	18.16	43.89	69.62	27.30	52.80	32.60
	kW	9.42	9.37	9.27	9.46	9.39	9.32	9.48	9.44	9.36
125	TC	91.12	83.24	75.36	83.38	73.78	64.19	75.60	64.20	83.20
	SHC	-6.40	22.82	52.03	5.87	34.80	63.73	15.60	44.30	22.80
	kW	10.35	10.30	10.20	10.39	10.32	10.25	10.41	10.37	10.29

## 48HC\*D11 — UNIT WITH HUMIDI-MIZER SYSTEM IN HOT GAS REHEAT MODE - 2-STAGE COOLING CAPACITIES

TEMP (F) AIR ENTERING CONDENSER (Edb)		AIR ENTERING EVAPORATOR - CFM								
		75 Dry Bulb 62.5 Wet Bulb (50% Relative Humidity)			75 Dry Bulb 64 Wet Bulb (56% Relative Humidity)			75 Dry Bulb 65.3 Wet Bulb (60% Relative Humidity)		
		Air Entering Evaporator - Ewb (F)								
		3000	4000	5000	3000	4000	5000	3000	4000	5000
		75	TC	46.00	49.70	52.50	50.20	52.60	55.00	51.40
SHC	8.50		18.40	26.50	3.60	11.90	18.50	-1.10	5.20	11.70
kW	6.56		6.50	6.42	6.55	6.48	6.40	6.53	6.49	6.40
85	TC	47.80	51.30	54.10	51.70	54.20	56.80	53.30	57.50	59.70
	SHC	10.20	20.00	28.20	5.30	13.40	20.10	0.50	6.80	13.20
	kW	6.51	6.45	6.36	6.50	6.44	6.35	6.47	6.44	6.35
95	TC	50.00	53.60	56.20	54.00	56.30	58.80	55.30	59.60	61.80
	SHC	12.00	21.60	29.80	6.90	15.00	21.70	2.20	8.50	14.70
	kW	6.45	6.40	6.29	6.45	6.39	6.28	6.42	6.39	6.28
105	TC	54.00	57.50	60.10	57.90	60.20	62.70	59.30	63.50	65.70
	SHC	15.20	24.70	31.90	10.20	18.30	24.90	5.40	11.80	18.00
	kW	6.33	6.28	6.19	6.33	6.27	6.17	6.30	6.27	6.17
115	TC	58.00	61.40	64.20	61.80	64.40	66.50	63.30	67.20	69.50
	SHC	18.50	28.00	36.20	13.50	21.50	28.20	8.70	15.10	21.30
	kW	6.22	6.17	6.10	6.22	6.16	6.08	6.19	6.16	6.08
125	TC	61.90	65.30	68.00	65.70	68.10	70.50	67.20	71.30	73.50
	SHC	21.70	31.10	39.30	16.70	24.90	31.20	12.00	18.30	24.60
	kW	6.10	6.05	5.98	6.10	6.04	5.96	6.07	6.04	5.96

### LEGEND

- Edb — Entering Wet-Bulb
- Ewb — Entering Wet-Bulb
- kW — Compressor Motor Power Input
- ldb — Leaving Dry-Bulb
- lwb — Leaving Wet-Bulb
- SHC — Sensible Heat Capacity (1000 Btuh) Gross
- TC — Total Capacity (1000 Btuh) Gross

### NOTES:

1. Direct interpolation is permissible. Do not extrapolate.
2. The following formulas may be used.

$$t_{ldb} = t_{edb} - \frac{\text{sensible capacity (Btuh)}}{1.10 \times \text{cfm}}$$

$t_{lwb}$  = Wet-bulb temperature corresponding to enthalpy of air leaving evaporator coil ( $h_{lwb}$ ).

$$h_{lwb} = h_{ewb} - \frac{\text{total capacity (Btuh)}}{4.5 \times \text{cfm}}$$

Where:  $h_{ewb}$  = Enthalpy of air entering evaporator coil.



## 48HC\*D12 — UNIT WITH HUMIDI-MIZER® SYSTEM IN SUBCOOLING MODE - 2-STAGE COOLING CAPACITIES

TEMP (F) AIR ENTERING CONDENSER (Edb)		AIR ENTERING EVAPORATOR - CFM								
		3000			4000			5000		
		Air Entering Evaporator - Ewb (F)								
		72	67	62	72	67	62	72	67	62
75	TC	135.80	123.10	111.60	144.00	130.90	119.20	148.70	135.70	122.90
	SHC	56.70	72.80	88.90	66.10	86.90	107.40	74.40	100.10	121.00
	kW	6.42	6.26	6.13	6.54	6.37	6.22	6.61	6.43	6.26
85	TC	127.30	115.40	104.50	134.90	120.10	111.70	139.30	126.90	116.80
	SHC	48.60	65.40	82.10	57.50	76.60	100.20	65.40	91.80	115.00
	kW	7.20	7.04	6.90	7.31	7.11	7.00	7.38	7.21	7.07
95	TC	118.10	106.50	96.90	125.20	113.60	103.60	129.50	117.80	108.40
	SHC	39.90	57.00	74.90	48.30	70.50	92.40	56.20	83.10	106.80
	kW	8.06	7.89	7.76	8.17	8.00	7.86	8.24	8.07	7.93
105	TC	107.30	97.80	87.80	114.50	103.80	94.50	117.60	107.30	99.00
	SHC	29.60	48.70	66.20	38.10	61.30	83.80	44.90	73.10	97.50
	kW	8.99	8.85	8.72	9.11	8.95	8.82	9.16	9.01	8.88
115	TC	95.70	86.30	78.20	102.10	91.30	83.40	105.70	95.80	88.20
	SHC	18.60	37.80	57.10	26.40	49.40	73.20	33.60	62.30	87.00
	kW	10.03	9.89	9.79	10.14	9.97	9.86	10.20	10.05	9.94
125	TC	83.70	75.20	67.70	87.50	80.10	72.50	92.10	83.10	75.20
	SHC	7.30	27.40	47.20	12.50	38.80	62.90	20.60	50.30	74.20
	kW	11.17	11.06	10.98	11.23	11.13	11.03	11.30	11.17	11.07

## 48HC\*D12 — UNIT WITH HUMIDI-MIZER SYSTEM IN HOT GAS REHEAT MODE - 2-STAGE COOLING CAPACITIES

TEMP (F) AIR ENTERING CONDENSER (Edb)		AIR ENTERING EVAPORATOR - CFM								
		75 Dry Bulb 62.5 Wet Bulb (50% Relative Humidity)			75 Dry Bulb 64 Wet Bulb (56% Relative Humidity)			75 Dry Bulb 65.3 Wet Bulb (60% Relative Humidity)		
		Air Entering Evaporator - Ewb (F)								
		3000	4000	5000	3000	4000	5000	3000	4000	5000
		80	TC	45.83	49.08	50.90	47.62	50.84	52.72	49.16
SHC	4.82		14.45	24.36	-1.60	6.39	14.99	-7.27	-0.59	6.73
kW	7.33		7.46	7.55	7.40	7.53	7.62	7.46	7.60	7.68
75	TC	48.52	51.89	53.81	50.31	53.74	55.73	51.92	55.47	57.43
	SHC	7.37	17.08	27.08	0.95	9.11	17.81	-4.65	2.25	9.63
	kW	6.93	7.07	7.15	7.00	7.14	7.23	7.06	7.21	7.29
70	TC	51.15	54.66	56.69	52.96	56.60	58.66	54.65	58.34	60.43
	SHC	9.87	19.70	29.80	3.47	11.82	20.57	-2.05	4.98	12.45
	kW	6.56	6.69	6.78	6.62	6.76	6.85	6.68	6.83	6.91
60	TC	52.89	56.41	59.04	55.63	59.10	62.68	58.00	62.31	64.50
	SHC	11.58	21.44	32.07	6.06	14.26	24.41	1.21	8.78	16.36
	kW	6.60	6.80	6.72	6.53	6.71	6.51	6.46	6.48	6.58
50	TC	55.13	59.53	62.75	58.04	62.61	64.69	59.64	64.34	66.41
	SHC	13.77	24.43	35.63	8.41	17.62	26.38	2.80	10.77	18.23
	kW	6.57	6.53	6.44	6.43	6.41	6.54	6.52	6.50	6.64
40	TC	57.08	60.11	64.35	58.75	63.63	65.58	60.16	65.23	69.04
	SHC	15.67	25.05	33.55	9.13	18.64	27.28	3.34	11.67	20.76
	kW	6.51	6.77	6.62	6.64	6.54	6.70	6.75	6.65	6.50

### LEGEND

- Edb — Entering Wet-Bulb
- Ewb — Entering Wet-Bulb
- kW — Compressor Motor Power Input
- ldb — Leaving Dry-Bulb
- lwb — Leaving Wet-Bulb
- SHC — Sensible Heat Capacity (1000 Btuh) Gross
- TC — Total Capacity (1000 Btuh) Gross

### NOTES:

1. Direct interpolation is permissible. Do not extrapolate.
2. The following formulas may be used.

$$t_{ldb} = t_{edb} - \frac{\text{sensible capacity (Btuh)}}{1.10 \times \text{cfm}}$$

$t_{lwb}$  = Wet-bulb temperature corresponding to enthalpy of air leaving evaporator coil ( $h_{lwb}$ ).

$$h_{lwb} = h_{ewb} - \frac{\text{total capacity (Btuh)}}{4.5 \times \text{cfm}}$$

Where:  $h_{ewb}$  = Enthalpy of air entering evaporator coil.



## 48HC\*D14 — UNIT WITH HUMIDI-MIZER® SYSTEM IN SUBCOOLING MODE - 2-STAGE COOLING CAPACITIES

TEMP (F) AIR ENTERING CONDENSER (Edb)		AIR ENTERING EVAPORATOR - CFM								
		3750			5000			6250		
		Air Entering Evaporator - Ewb (F)								
		72	67	62	72	67	62	72	67	62
75	TC	162.0	147.4	132.8	185.6	167.2	148.8	209.5	187.2	164.9
	SHC	85.0	101.4	117.4	96.9	113.0	129.0	106.5	122.4	138.4
	kW	7.7	7.6	7.3	7.9	7.7	7.4	8.1	7.8	7.5
85	TC	154.8	140.9	127.0	171.7	154.4	137.1	188.8	168.0	147.2
	SHC	70.2	90.4	110.6	83.1	103.2	123.2	93.4	113.4	133.3
	kW	8.8	8.7	8.3	8.9	8.7	8.4	9.1	8.8	8.5
95	TC	147.5	134.4	121.2	157.8	141.6	125.4	168.1	148.8	129.6
	SHC	55.5	79.7	103.9	69.3	93.4	117.5	80.4	104.3	128.3
	kW	9.8	9.7	9.3	9.9	9.7	9.5	10.1	9.8	9.6
105	TC	140.3	127.8	115.4	143.8	128.7	113.7	147.4	129.7	111.9
	SHC	40.9	69.0	97.2	55.5	83.6	111.7	67.3	95.3	111.9
	kW	10.8	10.7	10.3	10.9	10.7	10.5	11.1	10.8	10.6
115	TC	133.0	121.3	109.5	129.9	115.9	101.9	126.7	110.5	94.2
	SHC	26.2	58.3	90.4	41.8	73.8	101.9	54.2	86.2	94.2
	kW	11.8	11.7	11.4	11.9	11.7	11.6	12.1	11.8	11.7
125	TC	125.8	114.7	103.7	115.9	103.1	90.2	106.0	91.3	76.6
	SHC	11.5	47.6	83.7	28.0	64.0	90.2	41.2	77.2	76.6
	kW	12.8	12.7	12.4	12.9	12.7	12.6	13.1	12.8	12.7

## 48HC\*D14 — UNIT WITH HUMIDI-MIZER SYSTEM IN HOT GAS REHEAT MODE - 2-STAGE COOLING CAPACITIES

TEMP (F) AIR ENTERING CONDENSER (Edb)		AIR ENTERING EVAPORATOR - CFM								
		75 Dry Bulb			75 Dry Bulb			75 Dry Bulb		
		62.5 Wet Bulb			64 Wet Bulb			65.3 Wet Bulb		
		(50% Relative Humidity)			(56% Relative Humidity)			(60% Relative Humidity)		
		Air Entering Evaporator - Ewb (F)								
		3750	5000	6250	3750	5000	6250	3750	5000	6250
80	TC	57.70	60.00	66.40	60.20	66.80	69.50	64.30	69.10	72.30
	SHC	21.30	27.00	44.00	12.80	22.40	32.50	8.60	16.20	25.50
	kW	8.08	8.15	8.23	8.28	8.34	8.37	8.36	8.43	8.52
75	TC	59.00	61.20	67.90	61.40	68.10	71.00	65.80	70.70	73.70
	SHC	22.40	28.10	44.80	13.50	23.50	33.70	9.30	17.10	26.30
	kW	8.06	8.13	8.21	8.25	8.31	8.34	8.33	8.40	8.49
70	TC	60.40	62.90	69.20	63.10	69.40	72.50	67.00	72.00	75.00
	SHC	23.20	28.90	46.00	14.50	24.30	34.40	10.30	17.90	27.40
	kW	8.04	8.11	8.18	8.23	8.29	8.32	8.31	8.38	8.47
60	TC	63.40	65.70	72.00	65.90	72.30	75.20	70.00	74.80	77.80
	SHC	24.80	30.50	47.80	16.10	25.90	36.00	11.90	19.60	29.00
	kW	8.00	8.07	8.15	8.20	8.25	8.29	8.28	8.35	8.44
50	TC	66.20	68.60	74.30	68.80	74.60	78.20	72.80	77.80	80.70
	SHC	26.60	32.30	49.40	17.70	27.70	37.80	13.50	21.20	30.60
	kW	7.94	8.01	8.08	8.13	8.20	8.23	8.22	8.29	8.38
40	TC	69.10	71.60	77.80	71.80	78.00	81.00	75.70	80.60	83.70
	SHC	28.20	33.90	50.10	19.40	29.30	39.80	15.20	22.90	32.20
	kW	7.90	7.97	8.04	8.09	8.15	8.17	8.16	8.23	8.32

### LEGEND

- Edb** — Entering Wet-Bulb
- Ewb** — Entering Wet-Bulb
- kW** — Compressor Motor Power Input
- ldb** — Leaving Dry-Bulb
- lwb** — Leaving Wet-Bulb
- SHC** — Sensible Heat Capacity (1000 Btuh) Gross
- TC** — Total Capacity (1000 Btuh) Gross

### NOTES:

1. Direct interpolation is permissible. Do not extrapolate.
2. The following formulas may be used.

$$t_{ldb} = t_{edb} - \frac{\text{sensible capacity (Btuh)}}{1.10 \times \text{cfm}}$$

$t_{lwb}$  = Wet-bulb temperature corresponding to enthalpy of air leaving evaporator coil ( $h_{lwb}$ ).

$$h_{lwb} = h_{ewb} - \frac{\text{total capacity (Btuh)}}{4.5 \times \text{cfm}}$$

Where:  $h_{ewb}$  = Enthalpy of air entering evaporator coil.



## ECONOMIZER, BAROMETRIC RELIEF AND POWER EXHAUST PERFORMANCE — VERTICAL APPLICATIONS (EXCLUDES ENERGYX SYSTEMS)

### BAROMETRIC RELIEF FLOW - VERTICAL 3-10 TON

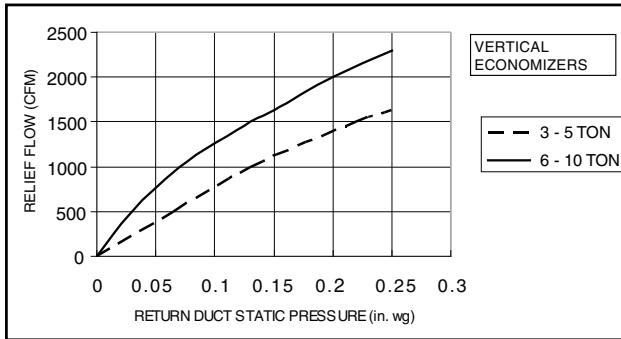

### BAROMETRIC RELIEF FLOW - VERTICAL 12.5 TON

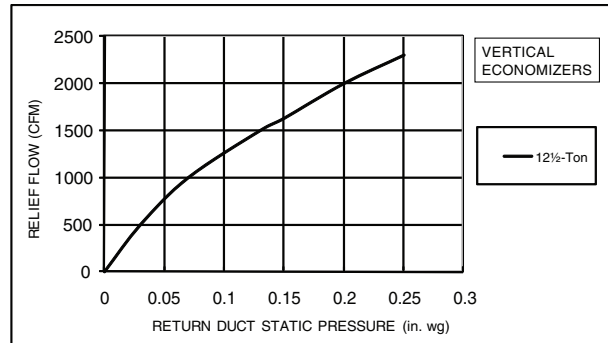

### RETURN AIR PRESSURE DROP - VERTICAL 3-10 TON

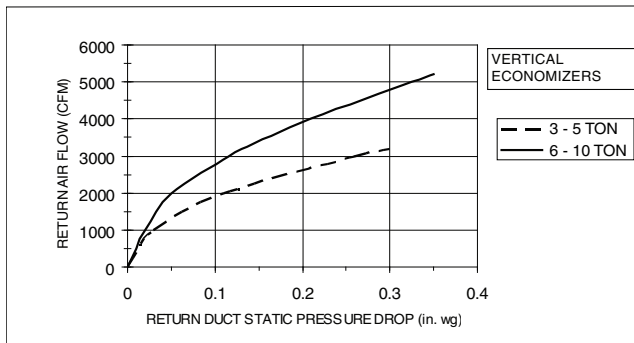

### RETURN AIR PRESSURE DROP - VERTICAL 12.5 TON

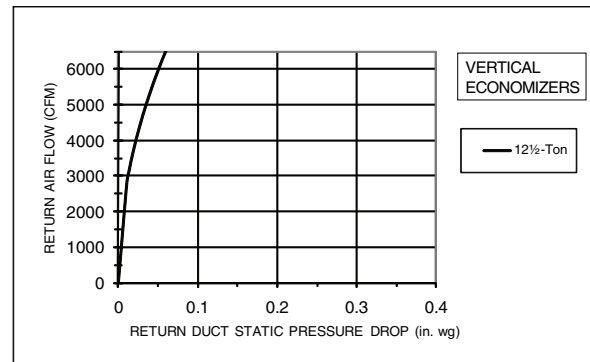

### VERTICAL POWER EXHAUST PERFORMANCE

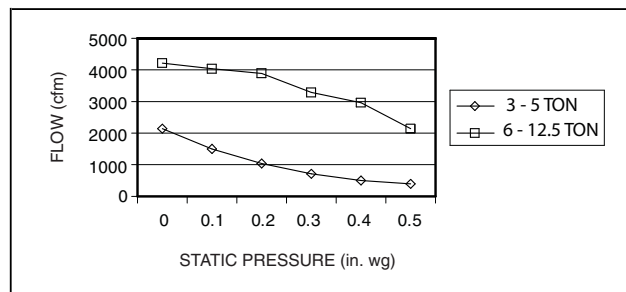

## ECONOMIZER, BAROMETRIC RELIEF AND POWER EXHAUST PERFORMANCE — HORIZONTAL APPLICATIONS (EXCLUDES ENERGYX SYSTEMS)

### BAROMETRIC RELIEF FLOW - HORIZONTAL 3-10 TON

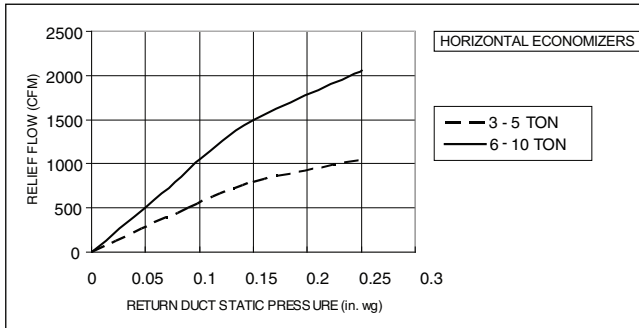

### BAROMETRIC RELIEF FLOW - HORIZONTAL 12.5 TON

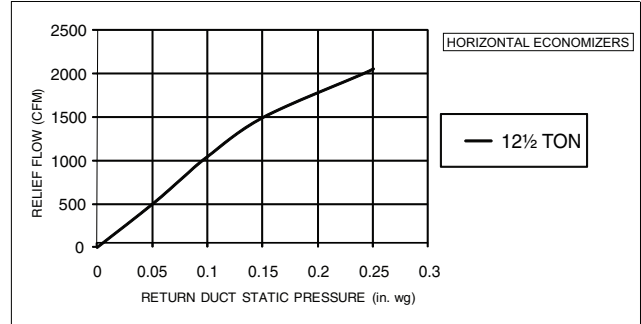

### RETURN AIR PRESSURE DROP - HORIZONTAL 3-10 TON

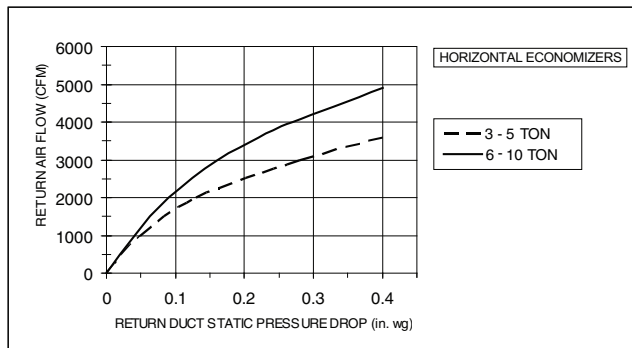

### RETURN AIR PRESSURE DROP - HORIZONTAL 12.5 TON

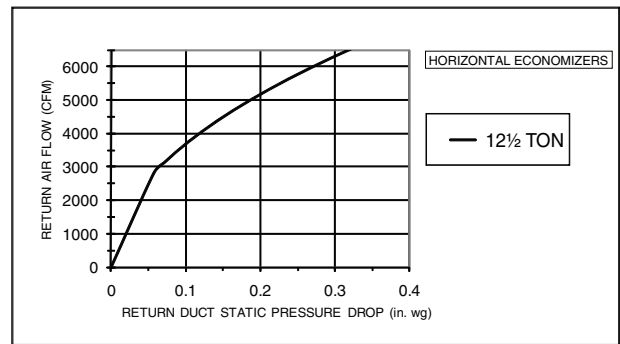

### HORIZONTAL POWER EXHAUST PERFORMANCE

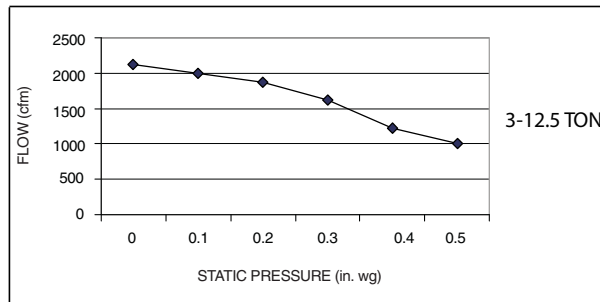

### 48HC UNITS WITH ENERGYX® SYSTEM – POWER EXHAUST PERFORMANCE

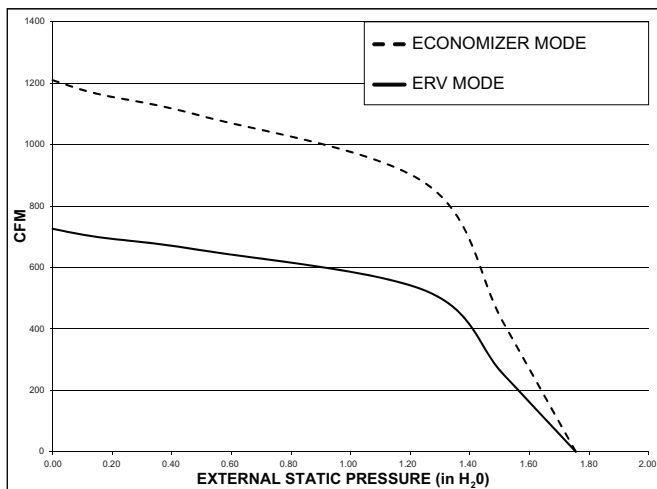

**48HC\*\*04**

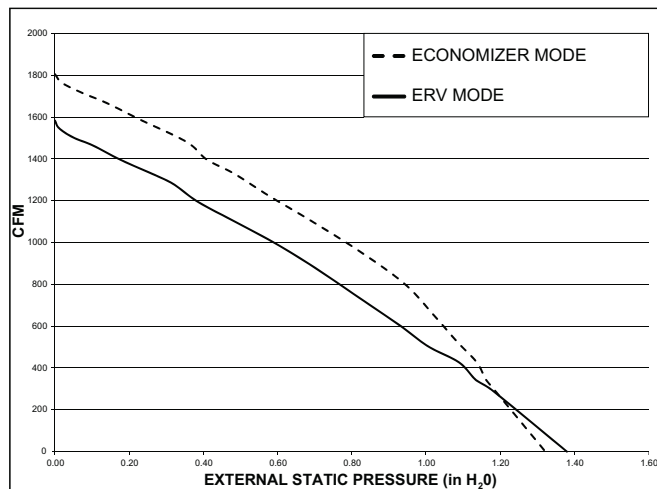

**48HC\*\*05-06**

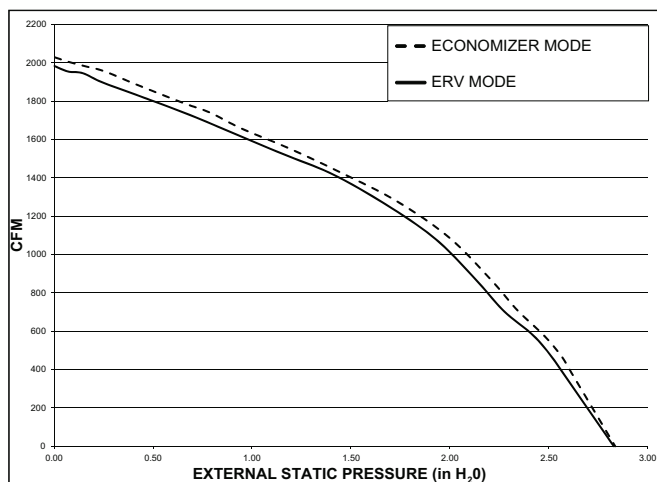

**48HC\*\*07**

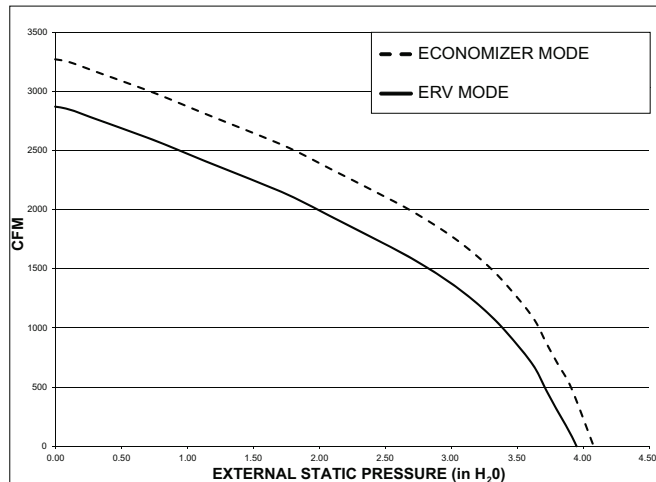

**48HC\*\*08-12**

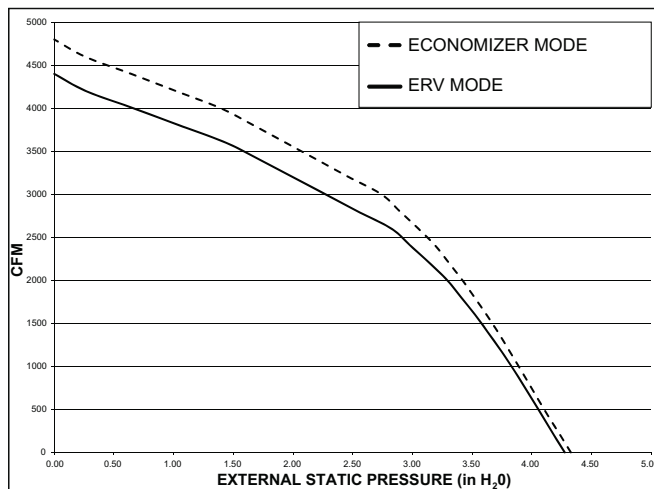

**48HC\*\*14**

## 48HC\*A04 VERTICAL UNIT - DIRECT DRIVE FAN PERFORMANCE

SPEED (TORQUE) TAP	CFM	ESP	BHP
1	900	0.30	0.19
	975	0.17	0.17
	1050	0.06	0.16
	1125	—	—
	1200	—	—
	1275	—	—
	1350	—	—
	1425	—	—
	1500	—	—
2	900	0.48	0.25
	975	0.34	0.23
	1050	0.20	0.22
	1125	0.07	0.20
	1200	—	—
	1275	—	—
	1350	—	—
	1425	—	—
	1500	—	—
3	900	0.84	0.38
	975	0.69	0.36
	1050	0.53	0.33
	1125	0.38	0.32
	1200	0.24	0.31
	1275	0.10	0.31
	1350	—	—
	1425	—	—
	1500	—	—
4	900	0.99	0.43
	975	0.88	0.43
	1050	0.75	0.43
	1125	0.61	0.43
	1200	0.47	0.42
	1275	0.33	0.40
	1350	0.19	0.38
	1425	—	—
	1500	—	—
5	900	1.10	0.47
	975	1.02	0.49
	1050	0.75	0.51
	1125	0.61	0.54
	1200	0.81	0.56
	1275	0.74	0.58
	1350	0.67	0.61
	1425	0.60	0.63
	1500	0.52	0.66

LEGEND

**BHP** — Brake Horsepower  
**ESP** — External Static Pressure

## 48HC\*A04 HORIZONTAL UNIT - DIRECT DRIVE FAN PERFORMANCE

SPEED (TORQUE) TAP	CFM	ESP	BHP
1	900	0.45	0.23
	975	0.33	0.22
	1050	0.22	0.20
	1125	0.12	0.19
	1200	0.05	0.17
	1275	—	—
	1350	—	—
	1425	—	—
	1500	—	—
2	900	0.66	0.30
	975	0.52	0.28
	1050	0.39	0.27
	1125	0.27	0.26
	1200	0.16	0.24
	1275	0.05	0.23
	1350	—	—
	1425	—	—
	1500	—	—
3	900	1.01	0.43
	975	0.88	0.41
	1050	0.73	0.39
	1125	0.59	0.38
	1200	0.46	0.36
	1275	0.33	0.36
	1350	0.21	0.33
	1425	0.09	0.31
	1500	—	—
4	900	1.13	0.46
	975	1.03	0.46
	1050	0.92	0.46
	1125	0.81	0.46
	1200	0.69	0.46
	1275	0.57	0.45
	1350	0.44	0.44
	1425	0.31	0.42
	1500	0.18	0.40
5	900	1.20	0.49
	975	1.14	0.51
	1050	0.92	0.53
	1125	0.81	0.55
	1200	0.95	0.57
	1275	0.90	0.60
	1350	0.84	0.62
	1425	0.78	0.65
	1500	0.72	0.68

LEGEND

**BHP** — Brake Horsepower  
**ESP** — External Static Pressure



**48HC\*A05 VERTICAL UNIT - DIRECT DRIVE FAN PERFORMANCE**

SPEED (TORQUE) TAP	CFM	ESP	BHP
1	1200	0.38	0.30
	1300	0.24	0.28
	1400	0.12	0.27
	1500	0.01	0.26
	1600	—	—
	1700	—	—
	1800	—	—
	1900	—	—
2	2000	—	—
	1200	0.49	0.34
	1300	0.34	0.32
	1400	0.20	0.31
	1500	0.05	0.29
	1600	—	—
	1700	—	—
	1800	—	—
3	1900	—	—
	2000	—	—
	1200	0.87	0.56
	1300	0.74	0.57
	1400	0.60	0.59
	1500	0.44	0.56
	1600	0.29	0.50
	1700	0.14	0.47
4	1800	0.02	0.46
	1900	—	—
	2000	—	—
	1200	0.93	0.57
	1300	0.83	0.60
	1400	0.72	0.63
	1500	0.60	0.63
	1600	0.48	0.62
5	1700	0.35	0.62
	1800	0.21	0.61
	1900	0.06	0.58
	2000	—	—
	1200	0.97	0.58
	1300	0.89	0.61
	1400	0.72	0.65
	1500	0.60	0.68
5	1600	0.64	0.72
	1700	0.55	0.75
	1800	0.46	0.79
	1900	0.35	0.82
	2000	0.25	0.86

LEGEND

**BHP** — Brake Horsepower  
**ESP** — External Static Pressure

**48HC\*A05 HORIZONTAL UNIT - DIRECT DRIVE FAN PERFORMANCE**

SPEED (TORQUE) TAP	CFM	ESP	BHP
1	1200	0.49	0.35
	1300	0.34	0.33
	1400	0.20	0.31
	1500	0.06	0.29
	1600	—	—
	1700	—	—
	1800	—	—
	1900	—	—
2	2000	—	—
	1200	0.60	0.40
	1300	0.45	0.38
	1400	0.30	0.36
	1500	0.16	0.34
	1600	0.01	0.32
	1700	—	—
	1800	—	—
3	1900	—	—
	2000	—	—
	1200	0.94	0.59
	1300	0.83	0.61
	1400	0.71	0.63
	1500	0.59	0.61
	1600	0.46	0.59
	1700	0.33	0.56
4	1800	0.19	0.53
	1900	0.07	0.49
	2000	—	—
	1200	0.98	0.59
	1300	0.89	0.62
	1400	0.81	0.65
	1500	0.72	0.66
	1600	0.62	0.67
5	1700	0.52	0.68
	1800	0.40	0.68
	1900	0.27	0.66
	2000	0.12	0.61
	1200	1.02	0.60
	1300	0.95	0.63
	1400	0.81	0.67
	1500	0.72	0.70
5	1600	0.74	0.74
	1700	0.67	0.78
	1800	0.59	0.82
	1900	0.51	0.86
	2000	0.42	0.89

LEGEND

**BHP** — Brake Horsepower  
**ESP** — External Static Pressure

# Fan data (cont)



## 48HC\*A06 VERTICAL UNIT - DIRECT DRIVE FAN PERFORMANCE

SPEED (TORQUE) TAP	CFM	ESP	BHP
1	1500	0.27	0.45
	1625	0.08	0.43
	1750	—	—
	1875	—	—
	2000	—	—
	2125	—	—
	2250	—	—
	2375	—	—
	2500	—	—
2	1500	0.48	0.57
	1625	0.26	0.55
	1750	0.08	0.53
	1875	—	—
	2000	—	—
	2125	—	—
	2250	—	—
	2375	—	—
	2500	—	—
3	1500	0.91	0.82
	1625	0.72	0.82
	1750	0.52	0.81
	1875	0.31	0.78
	2000	0.11	0.77
	2125	—	—
	2250	—	—
	2375	—	—
	2500	—	—
4	1500	0.98	0.85
	1625	0.82	0.89
	1750	0.66	0.92
	1875	0.50	0.90
	2000	0.32	0.92
	2125	0.13	0.86
	2250	—	—
	2375	—	—
	2500	—	—
5	1500	1.00	—
	1625	0.86	0.91
	1750	0.66	0.95
	1875	0.50	0.98
	2000	0.41	1.01
	2125	0.25	0.88
	2250	0.06	1.01
	2375	—	—
	2500	—	—

LEGEND

**BHP** — Brake Horsepower  
**ESP** — External Static Pressure

## 48HC\*A06 HORIZONTAL UNIT - DIRECT DRIVE FAN PERFORMANCE

SPEED (TORQUE) TAP	CFM	ESP	BHP
1	1500	0.40	0.50
	1625	0.20	0.48
	1750	0.04	0.45
	1875	—	—
	2000	—	—
	2125	—	—
	2250	—	—
	2375	—	—
	2500	—	—
2	1500	0.62	0.62
	1625	0.39	0.60
	1750	0.19	0.57
	1875	0.03	0.53
	2000	—	—
	2125	—	—
	2250	—	—
	2375	—	—
	2500	—	—
3	1500	1.04	0.87
	1625	0.87	0.88
	1750	0.68	0.88
	1875	0.48	0.84
	2000	0.28	0.84
	2125	0.07	0.84
	2250	—	—
	2375	—	—
	2500	—	—
4	1500	1.10	0.90
	1625	0.96	0.94
	1750	0.81	0.98
	1875	0.65	0.95
	2000	0.47	1.00
	2125	0.27	0.94
	2250	0.05	0.96
	2375	—	—
	2500	—	—
5	1500	1.12	0.92
	1625	1.00	0.96
	1750	0.81	1.00
	1875	0.65	1.04
	2000	0.56	1.08
	2125	0.39	0.95
	2250	0.19	1.09
	2375	—	—
	2500	—	—

LEGEND

**BHP** — Brake Horsepower  
**ESP** — External Static Pressure



### 48HC\*\*04 3 PHASE WITHOUT HUMIDI-MIZER®, 3 TON, HORIZONTAL SUPPLY — BELT DRIVE FAN PERFORMANCE

CFM	AVAILABLE EXTERNAL STATIC PRESSURE (in. wg)									
	0.2		0.4		0.6		0.8		1.0	
	RPM	BHP	RPM	BHP	RPM	BHP	RPM	BHP	RPM	BHP
900	582	0.14	715	0.24	825	0.35	921	0.48	1007	0.63
975	606	0.16	735	0.26	843	0.38	938	0.51	1023	0.66
1050	630	0.18	756	0.29	862	0.41	955	0.55	1040	0.70
1125	655	0.21	778	0.32	882	0.45	974	0.58	1057	0.74
1200	681	0.24	800	0.35	902	0.48	992	0.63	1074	0.78
1275	708	0.27	823	0.39	923	0.53	1012	0.67	1093	0.83
1350	735	0.31	847	0.43	945	0.57	1032	0.72	1112	0.88
1425	762	0.35	871	0.48	967	0.62	1053	0.77	1131	0.94
1500	790	0.40	896	0.53	990	0.67	1074	0.83	1151	1.00

CFM	AVAILABLE EXTERNAL STATIC PRESSURE (in. wg)									
	1.2		1.4		1.6		1.8		2.0	
	RPM	BHP	RPM	BHP	RPM	BHP	RPM	BHP	RPM	BHP
900	1086	0.79	1159	0.96	1228	1.14	1293	1.33	1354	1.53
975	1101	0.82	1174	0.99	1242	1.18	1306	1.37	1367	1.57
1050	1117	0.86	1189	1.03	1256	1.22	1320	1.41	1381	1.62
1125	1133	0.90	1204	1.08	1271	1.26	1335	1.46	1395	1.67
1200	1150	0.95	1221	1.13	1287	1.31	1350	1.51	1410	1.72
1275	1168	1.00	1237	1.18	1303	1.37	1365	1.57	1425	1.78
1350	1186	1.05	1255	1.24	1320	1.43	1382	1.63	1441	1.84
1425	1204	1.11	1272	1.30	1337	1.49	1398	1.70	1457	1.91
1500	1223	1.18	1291	1.36	1355	1.56	1415	1.77	1473	1.99

### 48HC\*\*04 3 PHASE WITHOUT HUMIDI-MIZER®, 3 TON, VERTICAL SUPPLY — BELT DRIVE FAN PERFORMANCE

CFM	AVAILABLE EXTERNAL STATIC PRESSURE (in. wg)									
	0.2		0.4		0.6		0.8		1.0	
	RPM	BHP	RPM	BHP	RPM	BHP	RPM	BHP	RPM	BHP
900	592	0.14	721	0.25	826	0.38	916	0.69	997	0.69
975	616	0.17	744	0.28	847	0.41	936	0.72	1016	0.72
1050	641	0.19	766	0.30	868	0.44	957	0.76	1036	0.76
1125	667	0.22	790	0.33	890	0.47	978	0.80	1056	0.80
1200	693	0.25	813	0.37	913	0.51	999	0.84	1077	0.84
1275	720	0.29	837	0.41	935	0.55	1021	0.88	1098	0.88
1350	747	0.33	862	0.45	958	0.60	1043	0.94	1119	0.94
1425	775	0.37	887	0.50	982	0.65	1066	0.99	1141	0.99
1500	802	0.42	912	0.55	1006	0.70	1088	1.05	1163	1.05

CFM	AVAILABLE EXTERNAL STATIC PRESSURE (in. wg)									
	1.2		1.4		1.6		1.8		2.0	
	RPM	BHP	RPM	BHP	RPM	BHP	RPM	BHP	RPM	BHP
900	1070	0.88	1137	1.07	1201	1.29	1260	1.51	1317	1.75
975	1089	0.91	1156	1.11	1219	1.32	1279	1.54	1335	1.78
1050	1108	0.94	1175	1.14	1238	1.36	1297	1.58	1353	1.82
1125	1128	0.98	1195	1.18	1257	1.40	1316	1.62	1372	1.86
1200	1148	1.03	1214	1.23	1276	1.44	1335	1.67	1391	1.91
1275	1169	1.07	1235	1.28	1296	1.50	1354	1.72	1410	1.97
1350	1190	1.13	1255	1.33	1316	1.55	1374	1.78	1429	2.03
1425	1211	1.19	1276	1.39	1337	1.61	1394	1.85	1449	2.09
1500	1232	1.25	1297	1.46	1357	1.68	1415	1.91	1469	2.16

NOTES:

- For more information, see fan performance notes on page 94.
- Boldface** indicates field-supplied drive is required.

Medium static 770-1175 RPM, 1.7 bhp max  
 High static 1035-1466 RPM, 2.4 bhp max

## 48HC\*\*04 3 PHASE WITH HUMIDI-MIZER®, 3 TON, HORIZONTAL SUPPLY — BELT DRIVE FAN PERFORMANCE

CFM	AVAILABLE EXTERNAL STATIC PRESSURE (in. wg)									
	0.2		0.4		0.6		0.8		1.0	
	RPM	BHP	RPM	BHP	RPM	BHP	RPM	BHP	RPM	BHP
900	582	0.14	715	0.24	825	0.35	921	0.48	1007	0.63
975	606	0.16	735	0.26	843	0.38	938	0.51	1023	0.66
1050	630	0.18	756	0.29	862	0.41	955	0.55	1040	0.70
1125	655	0.21	778	0.32	882	0.45	974	0.58	1057	0.74
1200	681	0.24	800	0.35	902	0.48	992	0.63	1074	0.78
1275	708	0.27	823	0.39	923	0.53	1012	0.67	1093	0.83
1350	735	0.31	847	0.43	945	0.57	1032	0.72	1112	0.88
1425	762	0.35	871	0.48	967	0.62	1053	0.77	1131	0.94
1500	790	0.40	896	0.53	990	0.67	1074	0.83	1151	1.00

CFM	AVAILABLE EXTERNAL STATIC PRESSURE (in. wg)									
	1.2		1.4		1.6		1.8		2.0	
	RPM	BHP	RPM	BHP	RPM	BHP	RPM	BHP	RPM	BHP
900	1086	0.79	1159	0.96	1228	1.14	1293	1.33	1354	1.53
975	1101	0.82	1174	0.99	1242	1.18	1306	1.37	1367	1.57
1050	1117	0.86	1189	1.03	1256	1.22	1320	1.41	1381	1.62
1125	1133	0.90	1204	1.08	1271	1.26	1335	1.46	1395	1.67
1200	1150	0.95	1221	1.13	1287	1.31	1350	1.51	1410	1.72
1275	1168	1.00	1237	1.18	1303	1.37	1365	1.57	1425	1.78
1350	1186	1.05	1255	1.24	1320	1.43	1382	1.63	1441	1.84
1425	1204	1.11	1272	1.30	1337	1.49	1398	1.70	1457	1.91
1500	1223	1.18	1291	1.36	1355	1.56	1415	1.77	<b>1473</b>	<b>1.99</b>

## 48HC\*\*04 3 PHASE WITH HUMIDI-MIZER®, 3 TON, VERTICAL SUPPLY — BELT DRIVE FAN PERFORMANCE

CFM	AVAILABLE EXTERNAL STATIC PRESSURE (in. wg)									
	0.2		0.4		0.6		0.8		1.0	
	RPM	BHP	RPM	BHP	RPM	BHP	RPM	BHP	RPM	BHP
900	592	0.14	721	0.25	826	0.38	916	0.53	997	0.69
975	616	0.17	744	0.28	847	0.41	936	0.56	1016	0.72
1050	641	0.19	766	0.30	868	0.44	957	0.59	1036	0.76
1125	667	0.22	790	0.33	890	0.47	978	0.63	1056	0.80
1200	693	0.25	813	0.37	913	0.51	999	0.67	1077	0.84
1275	720	0.29	837	0.41	935	0.55	1021	0.71	1098	0.88
1350	747	0.33	862	0.45	958	0.60	1043	0.76	1119	0.94
1425	775	0.37	887	0.50	982	0.65	1066	0.81	1141	0.99
1500	802	0.42	912	0.55	1006	0.70	1088	0.87	1163	1.05

CFM	AVAILABLE EXTERNAL STATIC PRESSURE (in. wg)									
	1.2		1.4		1.6		1.8		2.0	
	RPM	BHP	RPM	BHP	RPM	BHP	RPM	BHP	RPM	BHP
900	1070	0.88	1137	1.07	1201	1.29	1260	1.51	1317	1.75
975	1089	0.91	1156	1.11	1219	1.32	1279	1.54	1335	1.78
1050	1108	0.94	1175	1.14	1238	1.36	1297	1.58	1353	1.82
1125	1128	0.98	1195	1.18	1257	1.40	1316	1.62	1372	1.86
1200	1148	1.03	1214	1.23	1276	1.44	1335	1.67	1391	1.91
1275	1169	1.07	1235	1.28	1296	1.50	1354	1.72	1410	1.97
1350	1190	1.13	1255	1.33	1316	1.55	1374	1.78	1429	2.03
1425	1211	1.19	1276	1.39	1337	1.61	1394	1.85	1449	2.09
1500	1232	1.25	1297	1.46	1357	1.68	1415	1.91	<b>1469</b>	<b>2.16</b>

NOTES:

- For more information, see fan performance notes on page 94.
- Boldface** indicates field-supplied drive is required.

	Standard static 560-854 RPM, 1.7 bhp max
	Medium static 770-1175 RPM, 1.7 bhp max
	High static 1035-1466 RPM, 2.4 bhp max





**48HC\*\*04 1 PHASE WITHOUT HUMIDI-MIZER®, 3 TON, HORIZONTAL SUPPLY — BELT DRIVE FAN PERFORMANCE**

CFM	AVAILABLE EXTERNAL STATIC PRESSURE (in. wg)									
	0.2		0.4		0.6		0.8		1.0	
	RPM	BHP	RPM	BHP	RPM	BHP	RPM	BHP	RPM	BHP
900	582	0.14	715	0.24	825	0.35	921	0.48	1007	0.63
975	606	0.16	735	0.26	843	0.38	938	0.51	1023	0.66
1050	630	0.18	756	0.29	862	0.41	955	0.55	1040	0.70
1125	655	0.21	778	0.32	882	0.45	974	0.58	1057	0.74
1200	681	0.24	800	0.35	902	0.48	992	0.63	1074	0.78
1275	708	0.27	823	0.39	923	0.53	1012	0.67	1093	0.83
1350	735	0.31	847	0.43	945	0.57	1032	0.72	1112	0.88
1425	762	0.35	871	0.48	967	0.62	1053	0.77	1131	0.94
1500	790	0.40	896	0.53	990	0.67	1074	0.83	1151	1.00

CFM	AVAILABLE EXTERNAL STATIC PRESSURE (in. wg)									
	1.2		1.4		1.6		1.8		2.0	
	RPM	BHP	RPM	BHP	RPM	BHP	RPM	BHP	RPM	BHP
900	1086	0.79	1159	0.96	1228	1.14	—	—	—	—
975	1101	0.82	1174	0.99	1242	1.18	—	—	—	—
1050	1117	0.86	1189	1.03	—	—	—	—	—	—
1125	1133	0.90	1204	1.08	—	—	—	—	—	—
1200	1150	0.95	1221	1.13	—	—	—	—	—	—
1275	1168	1.00	1237	1.18	—	—	—	—	—	—
1350	1186	1.05	—	—	—	—	—	—	—	—
1425	1204	1.11	—	—	—	—	—	—	—	—
1500	1223	1.18	—	—	—	—	—	—	—	—

**48HC\*\*04 1 PHASE WITHOUT HUMIDI-MIZER®, 3 TON, VERTICAL SUPPLY — BELT DRIVE FAN PERFORMANCE**

CFM	AVAILABLE EXTERNAL STATIC PRESSURE (in. wg)									
	0.2		0.4		0.6		0.8		1.0	
	RPM	BHP	RPM	BHP	RPM	BHP	RPM	BHP	RPM	BHP
900	592	0.14	721	0.25	826	0.38	916	0.53	997	0.69
975	616	0.17	744	0.28	847	0.41	936	0.56	1016	0.72
1050	641	0.19	766	0.30	868	0.44	957	0.59	1036	0.76
1125	667	0.22	790	0.33	890	0.47	978	0.63	1056	0.80
1200	693	0.25	813	0.37	913	0.51	999	0.67	1077	0.84
1275	720	0.29	837	0.41	935	0.55	1021	0.71	1098	0.88
1350	747	0.33	862	0.45	958	0.60	1043	0.76	1119	0.94
1425	775	0.37	887	0.50	982	0.65	1066	0.81	1141	0.99
1500	802	0.42	912	0.55	1006	0.70	1088	0.87	1163	1.05

CFM	AVAILABLE EXTERNAL STATIC PRESSURE (in. wg)									
	1.2		1.4		1.6		1.8		2.0	
	RPM	BHP	RPM	BHP	RPM	BHP	RPM	BHP	RPM	BHP
900	1070	0.88	1137	1.07	—	—	—	—	—	—
975	1089	0.91	1156	1.11	—	—	—	—	—	—
1050	1108	0.94	1175	1.14	—	—	—	—	—	—
1125	1128	0.98	1195	1.18	—	—	—	—	—	—
1200	1148	1.03	—	—	—	—	—	—	—	—
1275	1169	1.07	—	—	—	—	—	—	—	—
1350	1190	1.13	—	—	—	—	—	—	—	—
1425	1211	1.19	—	—	—	—	—	—	—	—
1500	—	—	—	—	—	—	—	—	—	—

NOTES:

- For more information, see fan performance notes on page 94.
- Boldface** indicates field-supplied drive is required.

Standard static 560-854 RPM 1.2 bhp max  
 Medium static 770-1175 RPM, 1.2 bhp max

## 48HC\*\*05 3 PHASE WITHOUT HUMIDI-MIZER®, 4 TON, HORIZONTAL SUPPLY — BELT DRIVE FAN PERFORMANCE

CFM	AVAILABLE EXTERNAL STATIC PRESSURE (in. wg)									
	0.2		0.4		0.6		0.8		1.0	
	RPM	BHP	RPM	BHP	RPM	BHP	RPM	BHP	RPM	BHP
1200	681	0.24	800	0.35	902	0.48	992	0.63	1074	0.78
1300	717	0.29	831	0.41	930	0.54	1019	0.69	1099	0.85
1400	753	0.34	863	0.46	959	0.60	1046	0.75	1125	0.92
1500	790	0.40	896	0.53	990	0.67	1074	0.83	1151	1.00
1600	828	0.46	930	0.60	1021	0.75	1103	0.91	1179	1.09
1700	866	0.54	964	0.68	1053	0.84	1133	1.01	1207	1.18
1800	905	0.62	1000	0.77	1085	0.94	1164	1.11	1236	1.29
1900	944	0.71	1036	0.87	1119	1.04	1195	1.22	1266	1.41
2000	984	0.82	1072	0.98	1153	1.15	1227	1.34	1297	1.53

CFM	AVAILABLE EXTERNAL STATIC PRESSURE (in. wg)									
	1.2		1.4		1.6		1.8		2.0	
	RPM	BHP	RPM	BHP	RPM	BHP	RPM	BHP	RPM	BHP
1200	1150	0.95	1221	1.13	1287	1.31	1350	1.51	1410	1.72
1300	1173	1.02	1243	1.20	1309	1.39	1371	1.59	1430	1.80
1400	1198	1.09	1266	1.28	1331	1.47	1393	1.68	1451	1.89
1500	1223	1.18	1291	1.36	1355	1.56	1415	1.77	1473	1.99
1600	1249	1.27	1316	1.46	1379	1.66	1439	1.87	1496	2.09
1700	1277	1.37	1342	1.57	1404	1.77	1463	1.99	1520	2.21
1800	1305	1.48	1369	1.68	1430	1.89	1489	2.11	1545	2.34
1900	1333	1.60	1397	1.81	1457	2.02	1514	2.25	—	—
2000	1363	1.73	1425	1.94	1484	2.16	1541	2.39	—	—

## 48HC\*\*05 3 PHASE WITHOUT HUMIDI-MIZER®, 4 TON, VERTICAL SUPPLY — BELT DRIVE FAN PERFORMANCE

CFM	AVAILABLE EXTERNAL STATIC PRESSURE (in. wg)									
	0.2		0.4		0.6		0.8		1.0	
	RPM	BHP	RPM	BHP	RPM	BHP	RPM	BHP	RPM	BHP
1200	693	0.25	813	0.37	913	0.51	999	0.67	1077	0.84
1300	729	0.30	846	0.42	943	0.57	1028	0.73	1105	0.90
1400	765	0.35	879	0.48	974	0.63	1058	0.79	1134	0.97
1500	802	0.42	912	0.55	1006	0.70	1088	0.87	1163	1.05
1600	840	0.49	947	0.63	1038	0.78	1119	0.95	1193	1.14
1700	878	0.57	982	0.71	1071	0.87	1151	1.05	1224	1.24
1800	917	0.65	1017	0.81	1105	0.97	1183	1.15	1255	1.35
1900	956	0.75	1053	0.91	1139	1.08	1216	1.27	1287	1.47
2000	995	0.86	1090	1.02	1173	1.20	1249	1.39	1319	1.59

CFM	AVAILABLE EXTERNAL STATIC PRESSURE (in. wg)									
	1.2		1.4		1.6		1.8		2.0	
	RPM	BHP	RPM	BHP	RPM	BHP	RPM	BHP	RPM	BHP
1200	1148	1.03	1214	1.23	1276	1.44	1335	1.67	1391	1.91
1300	1176	1.09	1241	1.30	1303	1.51	1361	1.74	1416	1.98
1400	1204	1.17	1269	1.37	1330	1.59	1388	1.82	1442	2.07
1500	1232	1.25	1297	1.46	1357	1.68	1415	1.91	1469	2.16
1600	1262	1.34	1325	1.55	1385	1.78	1442	2.01	1496	2.26
1700	1291	1.44	1354	1.66	1414	1.89	1470	2.12	1524	2.37
1800	1322	1.55	1384	1.77	1443	2.00	1499	2.25	—	—
1900	1352	1.68	1414	1.90	1472	2.13	1528	2.38	—	—
2000	1384	1.81	1445	2.04	1502	2.27	—	—	—	—

### NOTES:

- For more information, see fan performance notes on page 94.
- Boldface** indicates field-supplied drive is required.

Medium static 920-1303 RPM, 1.7 bhp max  
 High static 1208-1550 RPM, 2.9 bhp max



### 48HC\*\*05 3 PHASE WITH HUMIDI-MIZER®, 4 TON, HORIZONTAL SUPPLY — BELT DRIVE FAN PERFORMANCE

CFM	AVAILABLE EXTERNAL STATIC PRESSURE (in. wg)									
	0.2		0.4		0.6		0.8		1.0	
	RPM	BHP	RPM	BHP	RPM	BHP	RPM	BHP	RPM	BHP
1200	681	0.24	800	0.35	902	0.48	992	0.63	1074	0.78
1300	717	0.29	831	0.41	930	0.54	1019	0.69	1099	0.85
1400	753	0.34	863	0.46	959	0.60	1046	0.75	1125	0.92
1500	790	0.40	896	0.53	990	0.67	1074	0.83	1151	1.00
1600	828	0.46	930	0.60	1021	0.75	1103	0.91	1179	1.09
1700	866	0.54	964	0.68	1053	0.84	1133	1.01	1207	1.18
1800	905	0.62	1000	0.77	1085	0.94	1164	1.11	1236	1.29
1900	944	0.71	1036	0.87	1119	1.04	1195	1.22	1266	1.41
2000	984	0.82	1072	0.98	1153	1.15	1227	1.34	1297	1.53

CFM	AVAILABLE EXTERNAL STATIC PRESSURE (in. wg)									
	1.2		1.4		1.6		1.8		2.0	
	RPM	BHP	RPM	BHP	RPM	BHP	RPM	BHP	RPM	BHP
1200	1150	0.95	1221	1.13	1287	1.31	1350	1.51	1410	1.72
1300	1173	1.02	1243	1.20	1309	1.39	1371	1.59	1430	1.80
1400	1198	1.09	1266	1.28	1331	1.47	1393	1.68	1451	1.89
1500	1223	1.18	1291	1.36	1355	1.56	1415	1.77	1473	1.99
1600	1249	1.27	1316	1.46	1379	1.66	1439	1.87	1496	2.09
1700	1277	1.37	1342	1.57	1404	1.77	1463	1.99	1520	2.21
1800	1305	1.48	1369	1.68	1430	1.89	1489	2.11	1545	2.34
1900	1333	1.60	1397	1.81	1457	2.02	1514	2.25	—	—
2000	1363	1.73	1425	1.94	1484	2.16	1541	2.39	—	—

### 48HC\*\*05 3 PHASE WITH HUMIDI-MIZER®, 4 TON, VERTICAL SUPPLY — BELT DRIVE FAN PERFORMANCE

CFM	AVAILABLE EXTERNAL STATIC PRESSURE (in. wg)									
	0.2		0.4		0.6		0.8		1.0	
	RPM	BHP	RPM	BHP	RPM	BHP	RPM	BHP	RPM	BHP
1200	693	0.25	813	0.37	913	0.51	999	0.67	1077	0.84
1300	729	0.30	846	0.42	943	0.57	1028	0.73	1105	0.90
1400	765	0.35	879	0.48	974	0.63	1058	0.79	1134	0.97
1500	802	0.42	912	0.55	1006	0.70	1088	0.87	1163	1.05
1600	840	0.49	947	0.63	1038	0.78	1119	0.95	1193	1.14
1700	878	0.57	982	0.71	1071	0.87	1151	1.05	1224	1.24
1800	917	0.65	1017	0.81	1105	0.97	1183	1.15	1255	1.35
1900	956	0.75	1053	0.91	1139	1.08	1216	1.27	1287	1.47
2000	995	0.86	1090	1.02	1173	1.20	1249	1.39	1319	1.59

CFM	AVAILABLE EXTERNAL STATIC PRESSURE (in. wg)									
	1.2		1.4		1.6		1.8		2.0	
	RPM	BHP	RPM	BHP	RPM	BHP	RPM	BHP	RPM	BHP
1200	1148	1.03	1214	1.23	1276	1.44	1335	1.67	1391	1.91
1300	1176	1.09	1241	1.30	1303	1.51	1361	1.74	1416	1.98
1400	1204	1.17	1269	1.37	1330	1.59	1388	1.82	1442	2.07
1500	1232	1.25	1297	1.46	1357	1.68	1415	1.91	1469	2.16
1600	1262	1.34	1325	1.55	1385	1.78	1442	2.01	1496	2.26
1700	1291	1.44	1354	1.66	1414	1.89	1470	2.12	1524	2.37
1800	1322	1.55	1384	1.77	1443	2.00	1499	2.25	—	—
1900	1352	1.68	1414	1.90	1472	2.13	1528	2.38	—	—
2000	1384	1.81	1445	2.04	1502	2.27	—	—	—	—

NOTES:

- For more information, see fan performance notes on page 94.
- Boldface** indicates field-supplied drive is required.

	Standard static 560-854 RPM, 1.7 bhp max
	Medium static 770-1175 RPM, 1.7 bhp max
	High static 1208-1550 RPM, 2.9 bhp max

## 48HC\*\*05 1 PHASE WITHOUT HUMIDI-MIZER®, 4 TON, HORIZONTAL SUPPLY — BELT DRIVE FAN PERFORMANCE

CFM	AVAILABLE EXTERNAL STATIC PRESSURE (in. wg)									
	0.2		0.4		0.6		0.8		1.0	
	RPM	BHP	RPM	BHP	RPM	BHP	RPM	BHP	RPM	BHP
1200	681	0.24	800	0.35	902	0.48	992	0.63	1074	0.78
1300	717	0.29	831	0.41	930	0.54	1019	0.69	1099	0.85
1400	753	0.34	863	0.46	959	0.60	1046	0.75	1125	0.92
1500	790	0.40	896	0.53	990	0.67	1074	0.83	1151	1.00
1600	828	0.46	930	0.60	1021	0.75	1103	0.91	1179	1.09
1700	866	0.54	964	0.68	1053	0.84	1133	1.01	1207	1.18
1800	905	0.62	1000	0.77	1085	0.94	1164	1.11	—	—
1900	944	0.71	1036	0.87	1119	1.04	—	—	—	—
2000	984	0.82	1072	0.98	1153	1.15	—	—	—	—

CFM	AVAILABLE EXTERNAL STATIC PRESSURE (in. wg)									
	1.2		1.4		1.6		1.8		2.0	
	RPM	BHP	RPM	BHP	RPM	BHP	RPM	BHP	RPM	BHP
1200	1150	0.95	1221	1.13	—	—	—	—	—	—
1300	1173	1.02	1243	1.20	—	—	—	—	—	—
1400	1198	1.09	—	—	—	—	—	—	—	—
1500	1223	1.18	—	—	—	—	—	—	—	—
1600	—	—	—	—	—	—	—	—	—	—
1700	—	—	—	—	—	—	—	—	—	—
1800	—	—	—	—	—	—	—	—	—	—
1900	—	—	—	—	—	—	—	—	—	—
2000	—	—	—	—	—	—	—	—	—	—

## 48HC\*\*05 1 PHASE WITHOUT HUMIDI-MIZER®, 4 TON, VERTICAL SUPPLY — BELT DRIVE FAN PERFORMANCE

CFM	AVAILABLE EXTERNAL STATIC PRESSURE (in. wg)									
	0.2		0.4		0.6		0.8		1.0	
	RPM	BHP	RPM	BHP	RPM	BHP	RPM	BHP	RPM	BHP
1200	693	0.25	813	0.37	913	0.51	999	0.67	1077	0.84
1300	729	0.30	846	0.42	943	0.57	1028	0.73	1105	0.90
1400	765	0.35	879	0.48	974	0.63	1058	0.79	1134	0.97
1500	802	0.42	912	0.55	1006	0.70	1088	0.87	1163	1.05
1600	840	0.49	947	0.63	1038	0.78	1119	0.95	1193	1.14
1700	878	0.57	982	0.71	1071	0.87	1151	1.05	—	—
1800	917	0.65	1017	0.81	1105	0.97	1183	1.15	—	—
1900	956	0.75	1053	0.91	1139	1.08	—	—	—	—
2000	995	0.86	1090	1.02	1173	1.20	—	—	—	—

CFM	AVAILABLE EXTERNAL STATIC PRESSURE (in. wg)									
	1.2		1.4		1.6		1.8		2.0	
	RPM	BHP	RPM	BHP	RPM	BHP	RPM	BHP	RPM	BHP
1200	1148	1.03	—	—	—	—	—	—	—	—
1300	1176	1.09	—	—	—	—	—	—	—	—
1400	1204	1.17	—	—	—	—	—	—	—	—
1500	—	—	—	—	—	—	—	—	—	—
1600	—	—	—	—	—	—	—	—	—	—
1700	—	—	—	—	—	—	—	—	—	—
1800	—	—	—	—	—	—	—	—	—	—
1900	—	—	—	—	—	—	—	—	—	—
2000	—	—	—	—	—	—	—	—	—	—

### NOTES:

- For more information, see fan performance notes on page 94.
- Boldface** indicates field-supplied drive is required.

Standard static 560-854 RPM, 1.2 bhp max  
Medium static 770-1175 RPM, 1.2 bhp max



### 48HC\*\*06 3 PHASE WITHOUT HUMIDI-MIZER®, 5 TON, HORIZONTAL SUPPLY — BELT DRIVE FAN PERFORMANCE

CFM	AVAILABLE EXTERNAL STATIC PRESSURE (in. wg)									
	0.2		0.4		0.6		0.8		1.0	
	RPM	BHP	RPM	BHP	RPM	BHP	RPM	BHP	RPM	BHP
1500	798	0.41	906	0.55	1002	0.71	1088	0.87	1167	1.05
1625	845	0.50	949	0.65	1041	0.81	1125	0.98	1202	1.17
1750	893	0.60	993	0.76	1081	0.93	1163	1.11	1238	1.30
1875	942	0.71	1037	0.88	1123	1.06	1202	1.25	1275	1.44
2000	992	0.84	1083	1.02	1166	1.21	1242	1.40	1313	1.61
2125	1043	0.98	1129	1.17	1209	1.37	1283	1.57	1353	1.79
2250	1093	1.14	1177	1.34	1254	1.55	1325	1.76	1393	1.98
2375	1145	1.32	1225	1.53	1299	1.74	1369	1.97	1434	2.20
2500	1196	1.51	1273	1.73	1345	1.96	1413	2.19	1477	2.43

CFM	AVAILABLE EXTERNAL STATIC PRESSURE (in. wg)									
	1.2		1.4		1.6		1.8		2.0	
	RPM	BHP	RPM	BHP	RPM	BHP	RPM	BHP	RPM	BHP
1500	1241	1.23	1310	1.42	1375	1.63	1438	1.84	1497	2.06
1625	1274	1.36	1342	1.56	1406	1.77	1467	1.98	1526	2.21
1750	1308	1.50	1375	1.70	1438	1.92	1498	2.14	—	—
1875	1344	1.65	1409	1.86	1471	2.09	1530	2.32	—	—
2000	1380	1.82	1444	2.04	1505	2.27	—	—	—	—
2125	1418	2.01	1481	2.24	1540	2.47	—	—	—	—
2250	1457	2.21	1518	2.45	—	—	—	—	—	—
2375	1497	2.43	—	—	—	—	—	—	—	—
2500	1538	2.68	—	—	—	—	—	—	—	—

### 48HC\*\*06 3 PHASE WITHOUT HUMIDI-MIZER®, 5 TON, VERTICAL SUPPLY — BELT DRIVE FAN PERFORMANCE

CFM	AVAILABLE EXTERNAL STATIC PRESSURE (in. wg)									
	0.2		0.4		0.6		0.8		1.0	
	RPM	BHP	RPM	BHP	RPM	BHP	RPM	BHP	RPM	BHP
1500	847	0.41	966	0.55	1067	0.68	1158	0.81	1240	0.93
1625	896	0.50	1010	0.65	1109	0.79	1198	0.93	1278	1.07
1750	947	0.59	1056	0.76	1152	0.92	1238	1.07	1318	1.22
1875	998	0.70	1103	0.88	1196	1.05	1280	1.22	1358	1.38
2000	1049	0.82	1151	1.02	1241	1.20	1323	1.38	1399	1.56
2125	1102	0.96	1199	1.17	1287	1.37	1367	1.56	1441	1.75
2250	1154	1.11	1248	1.33	1333	1.55	1411	1.75	1484	1.96
2375	1208	1.28	1298	1.52	1381	1.74	1457	1.96	1528	2.18
2500	1261	1.47	1349	1.72	1429	1.96	1503	2.19	—	—

CFM	AVAILABLE EXTERNAL STATIC PRESSURE (in. wg)									
	1.2		1.4		1.6		1.8		2.0	
	RPM	BHP	RPM	BHP	RPM	BHP	RPM	BHP	RPM	BHP
1500	1316	1.05	1387	1.17	1454	1.28	1517	1.39	—	—
1625	1353	1.20	1423	1.33	1489	1.46	—	—	—	—
1750	1391	1.36	1460	1.51	1525	1.65	—	—	—	—
1875	1430	1.54	1498	1.70	—	—	—	—	—	—
2000	1470	1.73	1537	1.90	—	—	—	—	—	—
2125	1511	1.93	—	—	—	—	—	—	—	—
2250	—	—	—	—	—	—	—	—	—	—
2375	—	—	—	—	—	—	—	—	—	—
2500	—	—	—	—	—	—	—	—	—	—

NOTES:

- For more information, see fan performance notes on page 94.
- Boldface** indicates field-supplied drive is required.

Medium static 906-1466 RPM, 2.4 bhp max  
High static 1303-1550 RPM, 2.9 bhp max

## 48HC\*\*06 3 PHASE WITH HUMIDI-MIZER®, 5 TON, HORIZONTAL SUPPLY — BELT DRIVE FAN PERFORMANCE

CFM	AVAILABLE EXTERNAL STATIC PRESSURE (in. wg)									
	0.2		0.4		0.6		0.8		1.0	
	RPM	BHP	RPM	BHP	RPM	BHP	RPM	BHP	RPM	BHP
1500	798	0.41	906	0.55	1002	0.71	1088	0.87	1167	1.05
1625	845	0.50	949	0.65	1041	0.81	1125	0.98	1202	1.17
1750	893	0.60	993	0.76	1081	0.93	1163	1.11	1238	1.30
1875	942	0.71	1037	0.88	1123	1.06	1202	1.25	1275	1.44
2000	992	0.84	1083	1.02	1166	1.21	1242	1.40	1313	1.61
2125	1043	0.98	1129	1.17	1209	1.37	1283	1.57	1353	1.79
2250	1093	1.14	1177	1.34	1254	1.55	1325	1.76	1393	1.98
2375	1145	1.32	1225	1.53	1299	1.74	1369	1.97	1434	2.20
2500	1196	1.51	1273	1.73	1345	1.96	1413	2.19	1477	2.43

CFM	AVAILABLE EXTERNAL STATIC PRESSURE (in. wg)									
	1.2		1.4		1.6		1.8		2.0	
	RPM	BHP	RPM	BHP	RPM	BHP	RPM	BHP	RPM	BHP
1500	1241	1.23	1310	1.42	1375	1.63	1438	1.84	1497	2.06
1625	1274	1.36	1342	1.56	1406	1.77	1467	1.98	1526	2.21
1750	1308	1.50	1375	1.70	1438	1.92	1498	2.14	—	—
1875	1344	1.65	1409	1.86	1471	2.09	1530	2.32	—	—
2000	1380	1.82	1444	2.04	1505	2.27	—	—	—	—
2125	1418	2.01	1481	2.24	1540	2.47	—	—	—	—
2250	1457	2.21	1518	2.45	—	—	—	—	—	—
2375	1497	2.43	—	—	—	—	—	—	—	—
2500	1538	2.68	—	—	—	—	—	—	—	—

## 48HC\*\*06 3 PHASE WITH HUMIDI-MIZER®, 5 TON, VERTICAL SUPPLY — BELT DRIVE FAN PERFORMANCE

CFM	AVAILABLE EXTERNAL STATIC PRESSURE (in. wg)									
	0.2		0.4		0.6		0.8		1.0	
	RPM	BHP	RPM	BHP	RPM	BHP	RPM	BHP	RPM	BHP
1500	847	0.41	966	0.55	1067	0.68	1158	0.81	1240	0.93
1625	896	0.50	1010	0.65	1109	0.79	1198	0.93	1278	1.07
1750	947	0.59	1056	0.76	1152	0.92	1238	1.07	1318	1.22
1875	998	0.70	1103	0.88	1196	1.05	1280	1.22	1358	1.38
2000	1049	0.82	1151	1.02	1241	1.20	1323	1.38	1399	1.56
2125	1102	0.96	1199	1.17	1287	1.37	1367	1.56	1441	1.75
2250	1154	1.11	1248	1.33	1333	1.55	1411	1.75	1484	1.96
2375	1208	1.28	1298	1.52	1381	1.74	1457	1.96	1528	2.18
2500	1261	1.47	1349	1.72	1429	1.96	1503	2.19	—	—

CFM	AVAILABLE EXTERNAL STATIC PRESSURE (in. wg)									
	1.2		1.4		1.6		1.8		2.0	
	RPM	BHP	RPM	BHP	RPM	BHP	RPM	BHP	RPM	BHP
1500	1316	1.05	1387	1.17	1454	1.28	1517	1.39	—	—
1625	1353	1.20	1423	1.33	1489	1.46	—	—	—	—
1750	1391	1.36	1460	1.51	1525	1.65	—	—	—	—
1875	1430	1.54	1498	1.70	—	—	—	—	—	—
2000	1470	1.73	1537	1.90	—	—	—	—	—	—
2125	1511	1.93	—	—	—	—	—	—	—	—
2250	—	—	—	—	—	—	—	—	—	—
2375	—	—	—	—	—	—	—	—	—	—
2500	—	—	—	—	—	—	—	—	—	—

### NOTES:

- For more information, see fan performance notes on page 94.
- Boldface** indicates field-supplied drive is required.

	Standard static 770-1175 RPM, 1.7 bhp max
	Medium static 1035-1466 RPM, 2.4 bhp max
	High static 1303-1550 RPM, 2.9 bhp max



**48HC\*\*06 1 PHASE WITHOUT HUMIDI-MIZER®, 5 TON, HORIZONTAL SUPPLY — BELT DRIVE FAN PERFORMANCE**

CFM	AVAILABLE EXTERNAL STATIC PRESSURE (in. wg)									
	0.2		0.4		0.6		0.8		1.0	
	RPM	BHP	RPM	BHP	RPM	BHP	RPM	BHP	RPM	BHP
1500	798	0.41	906	0.55	1002	0.71	1088	0.87	1167	1.05
1625	845	0.50	949	0.65	1041	0.81	1125	0.98	1202	1.17
1750	893	0.60	993	0.76	1081	0.93	1163	1.11	1238	1.30
1875	942	0.71	1037	0.88	1123	1.06	1202	1.25	1275	1.44
2000	992	0.84	1083	1.02	1166	1.21	1242	1.40	—	—
2125	1043	0.98	1129	1.17	1209	1.37	—	—	—	—
2250	1093	1.14	1177	1.34	—	—	—	—	—	—
2375	1145	1.32	1225	1.53	—	—	—	—	—	—
2500	1196	1.51	—	—	—	—	—	—	—	—

CFM	AVAILABLE EXTERNAL STATIC PRESSURE (in. wg)									
	1.2		1.4		1.6		1.8		2.0	
	RPM	BHP	RPM	BHP	RPM	BHP	RPM	BHP	RPM	BHP
1500	1241	1.23	1310	1.42	—	—	—	—	—	—
1625	1274	1.36	—	—	—	—	—	—	—	—
1750	1308	1.50	—	—	—	—	—	—	—	—
1875	—	—	—	—	—	—	—	—	—	—
2000	—	—	—	—	—	—	—	—	—	—
2125	—	—	—	—	—	—	—	—	—	—
2250	—	—	—	—	—	—	—	—	—	—
2375	—	—	—	—	—	—	—	—	—	—
2500	—	—	—	—	—	—	—	—	—	—

**48HC\*\*06 1 PHASE WITHOUT HUMIDI-MIZER®, 5 TON, VERTICAL SUPPLY — BELT DRIVE FAN PERFORMANCE**

CFM	AVAILABLE EXTERNAL STATIC PRESSURE (in. wg)									
	0.2		0.4		0.6		0.8		1.0	
	RPM	BHP	RPM	BHP	RPM	BHP	RPM	BHP	RPM	BHP
1500	847	0.41	966	0.55	1067	0.68	1158	0.81	1240	0.93
1625	896	0.50	1010	0.65	1109	0.79	1198	0.93	1278	1.07
1750	947	0.59	1056	0.76	1152	0.92	1238	1.07	1318	1.22
1875	998	0.70	1103	0.88	1196	1.05	1280	1.22	1358	1.38
2000	1049	0.82	1151	1.02	1241	1.20	1323	1.38	—	—
2125	1102	0.96	1199	1.17	1287	1.37	—	—	—	—
2250	1154	1.11	1248	1.33	—	—	—	—	—	—
2375	1208	1.28	1298	1.52	—	—	—	—	—	—
2500	1261	1.47	—	—	—	—	—	—	—	—

CFM	AVAILABLE EXTERNAL STATIC PRESSURE (in. wg)									
	1.2		1.4		1.6		1.8		2.0	
	RPM	BHP	RPM	BHP	RPM	BHP	RPM	BHP	RPM	BHP
1500	1316	1.05	1387	1.17	1454	1.28	1517	1.39	1578	1.50
1625	1353	1.20	1423	1.33	1489	1.46	—	—	—	—
1750	1391	1.36	1460	1.51	—	—	—	—	—	—
1875	—	—	—	—	—	—	—	—	—	—
2000	—	—	—	—	—	—	—	—	—	—
2125	—	—	—	—	—	—	—	—	—	—
2250	—	—	—	—	—	—	—	—	—	—
2375	—	—	—	—	—	—	—	—	—	—
2500	—	—	—	—	—	—	—	—	—	—

NOTES:

- For more information, see fan performance notes on page 94.
- Boldface** indicates field-supplied drive is required.

Standard static 770-1175 RPM, 1.2 bhp max  
 Medium static 1035-1466 RPM, 1.5 bhp max

## 48HC\*\*07 3 PHASE, 6 TON, HORIZONTAL SUPPLY — BELT DRIVE FAN PERFORMANCE

CFM	AVAILABLE EXTERNAL STATIC PRESSURE (in. wg)									
	0.2		0.4		0.6		0.8		1.0	
	RPM	BHP	RPM	BHP	RPM	BHP	RPM	BHP	RPM	BHP
1800	441	0.33	533	0.51	611	0.72	681	0.96	745	1.23
1950	462	0.38	550	0.58	626	0.80	694	1.04	757	1.31
2100	483	0.45	567	0.65	641	0.88	708	1.13	769	1.40
2250	505	0.52	586	0.73	657	0.97	722	1.22	782	1.50
2400	528	0.60	605	0.82	674	1.07	738	1.33	796	1.62
2550	550	0.69	625	0.92	692	1.17	754	1.45	811	1.74
2700	574	0.80	645	1.03	710	1.29	770	1.57	826	1.88
2850	597	0.91	666	1.16	729	1.43	788	1.71	843	2.02
3000	621	1.03	688	1.29	749	1.57	806	1.87	859	2.18

CFM	AVAILABLE EXTERNAL STATIC PRESSURE (in. wg)									
	1.2		1.4		1.6		1.8		2.0	
	RPM	BHP	RPM	BHP	RPM	BHP	RPM	BHP	RPM	BHP
1800	804	1.51	860	1.82	912	2.15	961	2.49	1008	2.85
1950	815	1.60	869	1.91	920	2.24	969	2.59	1016	2.96
2100	826	1.70	880	2.01	930	2.35	978	2.70	1024	3.07
2250	838	1.81	891	2.12	941	2.46	988	2.82	1033	3.19
2400	851	1.92	903	2.25	952	2.59	999	2.95	1043	3.33
2550	865	2.05	916	2.38	964	2.73	1010	3.10	1054	3.48
2700	879	2.19	929	2.53	976	2.88	1022	3.25	1066	3.64
2850	894	2.35	943	2.69	990	3.05	1035	3.43	1078	3.82
3000	910	2.51	958	2.86	1004	3.23	1048	3.61	1090	4.01

## 48HC\*\*07 3 PHASE, 6 TON, VERTICAL SUPPLY — BELT DRIVE FAN PERFORMANCE

CFM	AVAILABLE EXTERNAL STATIC PRESSURE (in. wg)									
	0.2		0.4		0.6		0.8		1.0	
	RPM	BHP	RPM	BHP	RPM	BHP	RPM	BHP	RPM	BHP
1800	449	0.34	539	0.53	615	0.75	681	0.99	742	1.26
1950	470	0.40	557	0.60	631	0.83	696	1.08	756	1.35
2100	491	0.47	576	0.68	648	0.91	712	1.17	771	1.45
2250	513	0.54	595	0.76	665	1.01	728	1.27	786	1.56
2400	536	0.63	615	0.86	684	1.11	745	1.39	802	1.68
2550	558	0.72	635	0.97	702	1.23	763	1.51	818	1.81
2700	582	0.83	656	1.08	721	1.35	781	1.65	835	1.95
2850	605	0.94	677	1.21	741	1.49	799	1.79	853	2.11
3000	629	1.07	699	1.35	761	1.64	818	1.95	871	2.28

CFM	AVAILABLE EXTERNAL STATIC PRESSURE (in. wg)									
	1.2		1.4		1.6		1.8		2.0	
	RPM	BHP	RPM	BHP	RPM	BHP	RPM	BHP	RPM	BHP
1800	797	1.54	848	1.84	896	2.16	942	2.49	985	2.84
1950	810	1.64	861	1.94	909	2.26	954	2.60	997	2.96
2100	824	1.74	875	2.06	922	2.38	967	2.73	1009	3.09
2250	839	1.86	889	2.18	935	2.52	980	2.87	1022	3.23
2400	854	1.99	903	2.32	950	2.66	993	3.02	1035	3.39
2550	870	2.13	918	2.46	964	2.81	1008	3.18	1049	3.55
2700	886	2.28	934	2.62	979	2.98	1022	3.35	1063	3.74
2850	903	2.44	950	2.79	995	3.16	1037	3.54	1078	3.93
3000	920	2.62	966	2.98	1010	3.35	1052	3.74	1093	4.14

NOTES:

- For more information, see fan performance notes on page 94.
- Boldface** indicates field-supplied drive is required.

	Standard static 489-747 RPM 1.7 bhp max
	Medium static 733-949 RPM, 2.9 bhp max
	High static 909-1102 RPM, 4.7 bhp max





### 48HC\*\*08 3 PHASE, 7.5 TON, HORIZONTAL SUPPLY — BELT DRIVE FAN PERFORMANCE

CFM	AVAILABLE EXTERNAL STATIC PRESSURE (in. wg)									
	0.2		0.4		0.6		0.8		1.0	
	RPM	BHP	RPM	BHP	RPM	BHP	RPM	BHP	RPM	BHP
2250	482	0.36	577	0.51	659	0.66	732	0.82	799	0.98
2438	505	0.43	597	0.59	676	0.75	748	0.92	813	1.09
2625	529	0.51	617	0.68	694	0.85	764	1.03	827	1.22
2813	554	0.60	638	0.78	713	0.97	781	1.16	843	1.35
3000	579	0.70	660	0.89	732	1.09	799	1.29	860	1.50
3188	604	0.81	683	1.02	753	1.23	817	1.44	877	1.65
3375	630	0.94	706	1.15	774	1.37	836	1.60	895	1.82
3563	657	1.08	729	1.31	795	1.54	856	1.77	913	2.01
3750	683	1.23	753	1.47	817	1.71	877	1.96	933	2.21

CFM	AVAILABLE EXTERNAL STATIC PRESSURE (in. wg)									
	1.2		1.4		1.6		1.8		2.0	
	RPM	BHP	RPM	BHP	RPM	BHP	RPM	BHP	RPM	BHP
2250	860	1.14	917	1.31	971	1.48	1022	1.66	1071	1.84
2438	873	1.27	929	1.45	983	1.63	1033	1.81	1081	2.00
2625	887	1.40	942	1.59	995	1.78	1045	1.98	<b>1092</b>	<b>2.18</b>
2813	901	1.55	956	1.75	1008	1.95	1057	2.15	<b>1104</b>	<b>2.36</b>
3000	917	1.70	970	1.91	1021	2.13	1070	2.34	<b>1117</b>	<b>2.56</b>
3188	933	1.87	986	2.09	1036	2.32	1084	2.54	<b>1130</b>	<b>2.77</b>
3375	950	2.05	1002	2.29	1051	2.52	<b>1098</b>	<b>2.76</b>	<b>1144</b>	<b>3.00</b>
3563	967	2.25	1018	2.49	1067	2.74	<b>1113</b>	<b>2.99</b>	<b>1158</b>	<b>3.24</b>
3750	985	2.46	1035	2.71	1083	2.97	<b>1129</b>	<b>3.23</b>	<b>1173</b>	<b>3.49</b>

### 48HC\*\*08 3 PHASE, 7.5 TON, VERTICAL SUPPLY — BELT DRIVE FAN PERFORMANCE

CFM	AVAILABLE EXTERNAL STATIC PRESSURE (in. wg)									
	0.2		0.4		0.6		0.8		1.0	
	RPM	BHP	RPM	BHP	RPM	BHP	RPM	BHP	RPM	BHP
2250	505	0.39	595	0.54	676	0.69	750	0.86	819	1.03
2438	532	0.47	617	0.63	694	0.79	766	0.97	833	1.15
2625	559	0.56	640	0.73	714	0.90	783	1.08	848	1.28
2813	588	0.67	664	0.84	735	1.03	801	1.22	864	1.42
3000	616	0.79	689	0.97	757	1.16	821	1.36	882	1.57
3188	646	0.92	715	1.11	780	1.31	842	1.52	901	1.74
3375	675	1.06	742	1.27	804	1.48	864	1.70	920	1.93
3563	705	1.23	769	1.44	829	1.66	886	1.89	941	2.13
3750	736	1.41	797	1.63	855	1.86	910	2.10	963	2.35

CFM	AVAILABLE EXTERNAL STATIC PRESSURE (in. wg)									
	1.2		1.4		1.6		1.8		2.0	
	RPM	BHP	RPM	BHP	RPM	BHP	RPM	BHP	RPM	BHP
2250	884	1.21	945	1.40	1003	1.60	1059	1.80	1112	2.01
2438	896	1.34	955	1.54	1012	1.74	1066	1.95	1118	2.17
2625	909	1.47	967	1.68	1022	1.89	1075	2.11	<b>1126</b>	<b>2.34</b>
2813	923	1.62	980	1.84	1034	2.06	1086	2.29	<b>1136</b>	<b>2.52</b>
3000	939	1.79	994	2.01	1047	2.24	<b>1098</b>	<b>2.47</b>	<b>1147</b>	<b>2.71</b>
3188	956	1.97	1010	2.20	1061	2.43	<b>1111</b>	<b>2.68</b>	<b>1159</b>	<b>2.93</b>
3375	975	2.16	1027	2.40	1077	2.65	<b>1125</b>	<b>2.90</b>	<b>1172</b>	<b>3.15</b>
3563	994	2.37	1044	2.62	<b>1093</b>	<b>2.87</b>	<b>1141</b>	<b>3.13</b>	<b>1186</b>	<b>3.40</b>
3750	1014	2.60	1063	2.86	<b>1111</b>	<b>3.12</b>	<b>1157</b>	<b>3.39</b>	<b>1202</b>	<b>3.66</b>

NOTES:

- For more information, see fan performance notes on page 94.
- Boldface** indicates field-supplied drive is required.

	Standard static 518-733 RPM 1.7 bhp max
	Medium static 690-936 RPM, 2.4 bhp max
	High static 838-1084 RPM, 3.7 bhp max

## 48HC\*\*09 3 PHASE, 8.5 TON, HORIZONTAL SUPPLY — BELT DRIVE FAN PERFORMANCE

CFM	AVAILABLE EXTERNAL STATIC PRESSURE (in. wg)									
	0.2		0.4		0.6		0.8		1.0	
	RPM	BHP	RPM	BHP	RPM	BHP	RPM	BHP	RPM	BHP
2550	520	0.47	609	0.64	687	0.81	757	0.99	821	1.16
2750	545	0.57	631	0.75	707	0.93	775	1.11	838	1.30
3000	579	0.70	660	0.89	732	1.09	799	1.29	860	1.50
3200	606	0.82	684	1.03	754	1.24	818	1.45	878	1.66
3400	634	0.95	709	1.17	777	1.40	839	1.62	897	1.85
3600	662	1.10	734	1.34	800	1.57	860	1.81	917	2.05
3850	698	1.32	766	1.56	829	1.81	888	2.07	943	2.32
4050	726	1.50	792	1.76	854	2.03	911	2.29	965	2.56
4250	756	1.71	819	1.98	879	2.26	934	2.53	987	2.81

CFM	AVAILABLE EXTERNAL STATIC PRESSURE (in. wg)									
	1.2		1.4		1.6		1.8		2.0	
	RPM	BHP	RPM	BHP	RPM	BHP	RPM	BHP	RPM	BHP
2550	881	1.35	937	1.53	990	1.72	1040	1.91	<b>1088</b>	<b>2.11</b>
2750	896	1.50	951	1.69	1003	1.89	1053	2.09	<b>1100</b>	<b>2.30</b>
3000	917	1.70	970	1.91	1021	2.13	1070	2.34	<b>1117</b>	<b>2.56</b>
3200	934	1.88	987	2.10	1037	2.33	<b>1085</b>	<b>2.56</b>	<b>1131</b>	<b>2.79</b>
3400	952	2.08	1004	2.31	1053	2.55	<b>1100</b>	<b>2.79</b>	<b>1145</b>	<b>3.03</b>
3600	971	2.29	1022	2.53	1070	2.78	<b>1116</b>	<b>3.03</b>	<b>1161</b>	<b>3.29</b>
3850	995	2.58	1045	2.84	<b>1092</b>	<b>3.10</b>	<b>1138</b>	<b>3.36</b>	<b>1181</b>	<b>3.63</b>
4050	1016	2.83	1064	3.10	<b>1111</b>	<b>3.37</b>	<b>1156</b>	<b>3.65</b>	<b>1199</b>	<b>3.93</b>
4250	1037	3.09	1084	3.38	<b>1130</b>	<b>3.66</b>	<b>1174</b>	<b>3.95</b>	<b>1216</b>	<b>4.24</b>

## 48HC\*\*09 3 PHASE, 8.5 TON, VERTICAL SUPPLY — BELT DRIVE FAN PERFORMANCE

CFM	AVAILABLE EXTERNAL STATIC PRESSURE (in. wg)									
	0.2		0.4		0.6		0.8		1.0	
	RPM	BHP	RPM	BHP	RPM	BHP	RPM	BHP	RPM	BHP
2550	548	0.52	631	0.69	706	0.86	776	1.04	841	1.22
2750	578	0.63	656	0.80	728	0.98	795	1.17	858	1.37
3000	616	0.79	689	0.97	757	1.16	821	1.36	882	1.57
3200	648	0.93	717	1.12	782	1.32	843	1.53	902	1.75
3400	679	1.09	745	1.29	808	1.50	867	1.72	923	1.95
3600	711	1.26	774	1.48	834	1.70	891	1.93	945	2.17
3850	752	1.51	812	1.74	868	1.98	923	2.22	975	2.47
4050	785	1.73	842	1.97	896	2.22	949	2.47	999	2.74
4250	818	1.98	873	2.23	925	2.49	976	2.75	1025	3.02

CFM	AVAILABLE EXTERNAL STATIC PRESSURE (in. wg)									
	1.2		1.4		1.6		1.8		2.0	
	RPM	BHP	RPM	BHP	RPM	BHP	RPM	BHP	RPM	BHP
2550	903	1.42	962	1.62	1018	1.83	1072	2.05	<b>1123</b>	<b>2.27</b>
2750	918	1.57	975	1.78	1030	2.00	1082	2.23	<b>1133</b>	<b>2.46</b>
3000	939	1.79	994	2.01	1047	2.24	<b>1098</b>	<b>2.47</b>	<b>1147</b>	<b>2.71</b>
3200	957	1.98	1011	2.21	1062	2.45	<b>1112</b>	<b>2.69</b>	<b>1160</b>	<b>2.94</b>
3400	977	2.19	1029	2.43	1079	2.67	<b>1127</b>	<b>2.93</b>	<b>1174</b>	<b>3.19</b>
3600	998	2.41	1048	2.66	<b>1097</b>	<b>2.92</b>	<b>1144</b>	<b>3.18</b>	<b>1189</b>	<b>3.45</b>
3850	1025	2.73	1074	2.99	<b>1121</b>	<b>3.26</b>	<b>1166</b>	<b>3.53</b>	<b>1210</b>	<b>3.81</b>
4050	1048	3.00	<b>1095</b>	<b>3.27</b>	<b>1141</b>	<b>3.55</b>	<b>1185</b>	<b>3.83</b>	<b>1228</b>	<b>4.12</b>
4250	1072	3.30	<b>1118</b>	<b>3.58</b>	<b>1162</b>	<b>3.87</b>	<b>1205</b>	<b>4.16</b>	<b>1247</b>	<b>4.46</b>

NOTES:

- For more information, see fan performance notes on page 94.
- Boldface** indicates field-supplied drive is required.

	Standard static 518-733 RPM, 1.7 bhp max
	Medium static 690-936 RPM, 2.4 bhp max
	High static 838-1084 RPM, 3.7 bhp max



**48HC\*\*11 3 PHASE, 10 TON, HORIZONTAL SUPPLY — BELT DRIVE FAN PERFORMANCE**

CFM	AVAILABLE EXTERNAL STATIC PRESSURE (in. wg)									
	0.2		0.4		0.6		0.8		1.0	
	RPM	BHP	RPM	BHP	RPM	BHP	RPM	BHP	RPM	BHP
3000	579	0.70	660	0.89	732	1.09	799	1.29	860	1.50
3250	613	0.85	690	1.06	760	1.27	823	1.49	883	1.71
3500	648	1.03	721	1.25	788	1.48	850	1.71	907	1.95
3750	683	1.23	753	1.47	817	1.71	877	1.96	933	2.21
4000	719	1.45	786	1.71	848	1.97	905	2.23	959	2.50
4250	756	1.71	819	1.98	879	2.26	934	2.53	987	2.81
4500	792	1.99	853	2.28	910	2.57	964	2.87	1015	3.16
4750	830	2.31	888	2.62	943	2.92	995	3.23	1044	3.54
5000	867	2.66	923	2.98	976	3.30	1026	3.63	1074	3.95

CFM	AVAILABLE EXTERNAL STATIC PRESSURE (in. wg)									
	1.2		1.4		1.6		1.8		2.0	
	RPM	BHP	RPM	BHP	RPM	BHP	RPM	BHP	RPM	BHP
3000	917	1.70	970	1.91	1021	2.13	1070	2.34	1117	2.56
3250	938	1.93	991	2.16	1041	2.38	1089	2.61	1134	2.85
3500	961	2.18	1013	2.42	1062	2.66	1108	2.91	1153	3.15
3750	985	2.46	1035	2.71	1083	2.97	1129	3.23	1173	3.49
4000	1011	2.76	1059	3.03	1106	3.30	1151	3.58	1194	3.85
4250	1037	3.09	1084	3.38	1130	3.66	1174	3.95	1216	4.24
4500	1064	3.46	1110	3.76	1155	4.06	1198	4.36	1239	4.66
4750	1091	3.85	1137	4.16	1180	4.48	—	—	—	—
5000	1120	4.28	1164	4.61	—	—	—	—	—	—

**48HC\*\*11 3 PHASE, 10 TON, VERTICAL SUPPLY — BELT DRIVE FAN PERFORMANCE**

CFM	AVAILABLE EXTERNAL STATIC PRESSURE (in. wg)									
	0.2		0.4		0.6		0.8		1.0	
	RPM	BHP	RPM	BHP	RPM	BHP	RPM	BHP	RPM	BHP
3000	616	0.79	689	0.97	757	1.16	821	1.36	882	1.57
3250	655	0.96	724	1.16	788	1.37	849	1.58	907	1.80
3500	695	1.17	760	1.38	821	1.60	879	1.83	934	2.06
3750	736	1.41	797	1.63	855	1.86	910	2.10	963	2.35
4000	777	1.68	834	1.91	889	2.16	942	2.41	993	2.67
4250	818	1.98	873	2.23	925	2.49	976	2.75	1025	3.02
4500	860	2.32	912	2.58	962	2.85	1010	3.13	1057	3.41
4750	902	2.69	951	2.97	999	3.26	1046	3.55	1091	3.84
5000	944	3.11	991	3.40	1037	3.70	1082	4.00	1125	4.31

CFM	AVAILABLE EXTERNAL STATIC PRESSURE (in. wg)									
	1.2		1.4		1.6		1.8		2.0	
	RPM	BHP	RPM	BHP	RPM	BHP	RPM	BHP	RPM	BHP
3000	939	1.79	994	2.01	1047	2.24	1098	2.47	1147	2.71
3250	962	2.03	1015	2.26	1066	2.50	1115	2.75	1163	3.00
3500	987	2.30	1038	2.54	1088	2.80	1135	3.05	1181	3.32
3750	1014	2.60	1063	2.86	1111	3.12	1157	3.39	1202	3.66
4000	1042	2.93	1090	3.20	1136	3.48	1180	3.76	1224	4.04
4250	1072	3.30	1118	3.58	1162	3.87	1205	4.16	<b>1247</b>	<b>4.46</b>
4500	1103	3.70	1147	4.00	1190	4.29	1232	4.60	—	—
4750	1135	4.14	1177	4.45	—	—	—	—	—	—
5000	1167	4.63	—	—	—	—	—	—	—	—

NOTES:

- For more information, see fan performance notes on page 94.
- Boldface** indicates field-supplied drive is required.

	Standard static 591-838 RPM, 2.4 bhp max
	Medium static 838-1084 RPM, 3.7 bhp max
	High static 1022-1240 RPM, 4.9 bhp max

## 48HC\*\*12 3 PHASE, 10 TON, HORIZONTAL SUPPLY — BELT DRIVE FAN PERFORMANCE

CFM	AVAILABLE EXTERNAL STATIC PRESSURE (in. wg)									
	0.2		0.4		0.6		0.8		1.0	
	RPM	BHP	RPM	BHP	RPM	BHP	RPM	BHP	RPM	BHP
3000	579	0.70	660	0.89	732	1.09	799	1.29	860	1.50
3250	613	0.85	690	1.06	760	1.27	823	1.49	883	1.71
3500	648	1.03	721	1.25	788	1.48	850	1.71	907	1.95
3750	683	1.23	753	1.47	817	1.71	877	1.96	933	2.21
4000	719	1.45	786	1.71	848	1.97	905	2.23	959	2.50
4250	756	1.71	819	1.98	879	2.26	934	2.53	987	2.81
4500	792	1.99	853	2.28	910	2.57	964	2.87	1015	3.16
4750	830	2.31	888	2.62	943	2.92	995	3.23	1044	3.54
5000	867	2.66	923	2.98	976	3.30	1026	3.63	1074	3.95

CFM	AVAILABLE EXTERNAL STATIC PRESSURE (in. wg)									
	1.2		1.4		1.6		1.8		2.0	
	RPM	BHP	RPM	BHP	RPM	BHP	RPM	BHP	RPM	BHP
3000	917	1.70	970	1.91	1021	2.13	1070	2.34	1117	2.56
3250	938	1.93	991	2.16	1041	2.38	1089	2.61	1134	2.85
3500	961	2.18	1013	2.42	1062	2.66	1108	2.91	1153	3.15
3750	985	2.46	1035	2.71	1083	2.97	1129	3.23	1173	3.49
4000	1011	2.76	1059	3.03	1106	3.30	1151	3.58	1194	3.85
4250	1037	3.09	1084	3.38	1130	3.66	1174	3.95	1216	4.24
4500	1064	3.46	1110	3.76	1155	4.06	1198	4.36	1239	4.66
4750	1091	3.85	1137	4.16	1180	4.48	—	—	—	—
5000	1120	4.28	1164	4.61	—	—	—	—	—	—

## 48HC\*\*12 3 PHASE, 10 TON, VERTICAL SUPPLY — BELT DRIVE FAN PERFORMANCE

CFM	AVAILABLE EXTERNAL STATIC PRESSURE (in. wg)									
	0.2		0.4		0.6		0.8		1.0	
	RPM	BHP	RPM	BHP	RPM	BHP	RPM	BHP	RPM	BHP
3000	616	0.79	689	0.97	757	1.16	821	1.36	882	1.57
3250	655	0.96	724	1.16	788	1.37	849	1.58	907	1.80
3500	695	1.17	760	1.38	821	1.60	879	1.83	934	2.06
3750	736	1.41	797	1.63	855	1.86	910	2.10	963	2.35
4000	777	1.68	834	1.91	889	2.16	942	2.41	993	2.67
4250	818	1.98	873	2.23	925	2.49	976	2.75	1025	3.02
4500	860	2.32	912	2.58	962	2.85	1010	3.13	1057	3.41
4750	902	2.69	951	2.97	999	3.26	1046	3.55	1091	3.84
5000	944	3.11	991	3.40	1037	3.70	1082	4.00	1125	4.31

CFM	AVAILABLE EXTERNAL STATIC PRESSURE (in. wg)									
	1.2		1.4		1.6		1.8		2.0	
	RPM	BHP	RPM	BHP	RPM	BHP	RPM	BHP	RPM	BHP
3000	939	1.79	994	2.01	1047	2.24	1098	2.47	1147	2.71
3250	962	2.03	1015	2.26	1066	2.50	1115	2.75	1163	3.00
3500	987	2.30	1038	2.54	1088	2.80	1135	3.05	1181	3.32
3750	1014	2.60	1063	2.86	1111	3.12	1157	3.39	1202	3.66
4000	1042	2.93	1090	3.20	1136	3.48	1180	3.76	1224	4.04
4250	1072	3.30	1118	3.58	1162	3.87	1205	4.16	<b>1247</b>	<b>4.46</b>
4500	1103	3.70	1147	4.00	1190	4.29	1232	4.60	—	—
4750	1135	4.14	1177	4.45	—	—	—	—	—	—
5000	1167	4.63	—	—	—	—	—	—	—	—

NOTES:

- For more information, see fan performance notes on page 94.
- Boldface** indicates field-supplied drive is required.

	Standard static 591-838 RPM, 2.4 bhp max
	Medium static 838-1084 RPM, 3.7 bhp max
	High static 1022-1240 RPM, 4.9 bhp max



### 48HC\*\*14 3 PHASE, 12.5 TON, HORIZONTAL SUPPLY — BELT DRIVE FAN PERFORMANCE

CFM	AVAILABLE EXTERNAL STATIC PRESSURE (in. wg)									
	0.2		0.4		0.6		0.8		1.0	
	RPM	BHP	RPM	BHP	RPM	BHP	RPM	BHP	RPM	BHP
3438	421	0.57	493	0.78	561	1.02	627	1.30	688	1.62
3750	445	0.69	512	0.91	576	1.17	638	1.45	697	1.77
4063	470	0.84	533	1.07	593	1.33	651	1.62	707	1.94
4375	496	1.00	555	1.25	612	1.52	666	1.82	720	2.14
4688	522	1.19	579	1.46	632	1.74	683	2.04	734	2.37
5000	549	1.41	602	1.68	653	1.98	702	2.29	750	2.62
5313	576	1.64	627	1.94	675	2.24	721	2.57	767	2.91
5625	603	1.91	652	2.22	698	2.54	742	2.87	786	3.23
5938	630	2.20	677	2.53	721	2.87	764	3.21	805	3.57
6250	657	2.53	702	2.87	745	3.22	786	3.58	826	3.96

CFM	AVAILABLE EXTERNAL STATIC PRESSURE (in. wg)									
	1.2		1.4		1.6		1.8		2.0	
	RPM	BHP	RPM	BHP	RPM	BHP	RPM	BHP	RPM	BHP
3438	746	1.96	799	2.32	849	2.70	896	3.09	940	3.50
3750	753	2.12	806	2.48	856	2.88	903	3.28	947	3.70
4063	761	2.29	813	2.67	862	3.07	909	3.48	953	3.92
4375	771	2.50	821	2.88	869	3.28	916	3.70	<b>960</b>	<b>4.15</b>
4688	783	2.73	831	3.11	878	3.52	923	3.95	<b>966</b>	<b>4.40</b>
5000	797	2.99	843	3.37	888	3.78	931	4.22	<b>974</b>	<b>4.67</b>
5313	812	3.28	856	3.67	899	4.08	941	4.52	<b>983</b>	<b>4.98</b>
5625	828	3.60	870	3.99	912	4.41	953	4.85	<b>993</b>	<b>5.31</b>
5938	846	3.95	886	4.36	926	4.78	<b>965</b>	<b>5.22</b>	<b>1004</b>	<b>5.69</b>
6250	865	4.35	904	4.75	942	5.18	<b>979</b>	<b>5.63</b>	—	—

### 48HC\*\*14 3 PHASE, 12.5 TON, VERTICAL SUPPLY — BELT DRIVE FAN PERFORMANCE

CFM	AVAILABLE EXTERNAL STATIC PRESSURE (in. wg)									
	0.2		0.4		0.6		0.8		1.0	
	RPM	BHP	RPM	BHP	RPM	BHP	RPM	BHP	RPM	BHP
3438	431	0.59	504	0.81	574	1.08	643	1.40	706	1.74
3750	456	0.71	524	0.95	589	1.22	653	1.54	715	1.90
4063	481	0.86	546	1.11	606	1.39	666	1.71	725	2.07
4375	507	1.03	569	1.30	626	1.59	681	1.91	736	2.27
4688	533	1.22	593	1.51	647	1.81	698	2.13	750	2.49
5000	560	1.44	617	1.74	669	2.05	718	2.39	766	2.75
5313	587	1.68	642	2.00	691	2.33	738	2.67	784	3.04
5625	614	1.95	667	2.29	715	2.63	760	2.99	804	3.36
5938	642	2.25	692	2.60	739	2.97	782	3.34	824	3.72
6250	670	2.58	718	2.95	763	3.33	805	3.72	846	4.11

CFM	AVAILABLE EXTERNAL STATIC PRESSURE (in. wg)									
	1.2		1.4		1.6		1.8		2.0	
	RPM	BHP	RPM	BHP	RPM	BHP	RPM	BHP	RPM	BHP
3438	763	2.10	815	2.46	862	2.82	905	3.18	946	3.55
3750	772	2.28	825	2.66	873	3.05	918	3.45	<b>959</b>	<b>3.84</b>
4063	781	2.46	834	2.87	883	3.29	929	3.71	<b>971</b>	<b>4.14</b>
4375	790	2.66	843	3.09	892	3.53	938	3.98	<b>982</b>	<b>4.43</b>
4688	801	2.89	852	3.32	901	3.78	947	4.25	<b>991</b>	<b>4.73</b>
5000	814	3.15	863	3.58	910	4.04	<b>956</b>	<b>4.53</b>	<b>999</b>	<b>5.03</b>
5313	830	3.44	875	3.87	920	4.33	<b>965</b>	<b>4.83</b>	<b>1008</b>	<b>5.34</b>
5625	847	3.77	890	4.20	933	4.66	<b>975</b>	<b>5.15</b>	<b>1017</b>	<b>5.67</b>
5938	865	4.13	906	4.56	947	5.03	<b>987</b>	<b>5.52</b>	<b>1028</b>	<b>6.04</b>
6250	885	4.53	924	4.97	962	5.43	<b>1001</b>	<b>5.92</b>	—	—

NOTES:

- For more information, see fan performance notes on page 94.
- Boldface** indicates field-supplied drive is required.

	Standard static 440-609 RPM, 2.9 bhp max
	Medium static 609-778 RPM, 3.7 bhp max
	High static 776-955 RPM, 6.1 bhp max

### FAN PERFORMANCE NOTES:

1. Interpolation is permissible. Do not extrapolate.
2. External static pressure is the static pressure difference between the return duct and the supply duct plus the static pressure caused by any FIOPs or accessories.
3. Tabular data accounts for pressure loss due to clean filters, unit casing, and wet coils. Factory options and accessories may add static pressure losses. Selection software is available, through your salesperson, to help you select the best motor/drive combination for your application.
4. The Fan Performance tables offer motor/drive recommendations. In cases when two motor/drive combinations would work, Carrier recommended the lower horsepower option.
5. For information on the electrical properties of Carrier motors, please see the Electrical Data section of this book.
6. For more information on the performance limits of Carrier motors, see the application data section of this book.
7. The EPACT (Energy Policy Act of 1992) regulates energy requirements for specific types of indoor fan motors. Motors regulated by EPACT include any general purpose, T-frame (three-digit, 143 and larger), single-speed, foot mounted, polyphase, squirrel cage induction motors of NEMA (National Electrical Manufacturers Association) design A and B, manufactured for use in the United States. Ranging from 1 to 200 Hp, these continuous-duty motors operate on 230 and 460 volt, 60 Hz power. If a motor does not fit into these specifications, the motor does not have to be replaced by an EPACT compliant energy-efficient motor. Variable-speed motors are exempt from EPACT compliance requirements.

## 48HC 08, 09 TYPICAL POWER WIRING DIAGRAM, 208/230V AND 460V

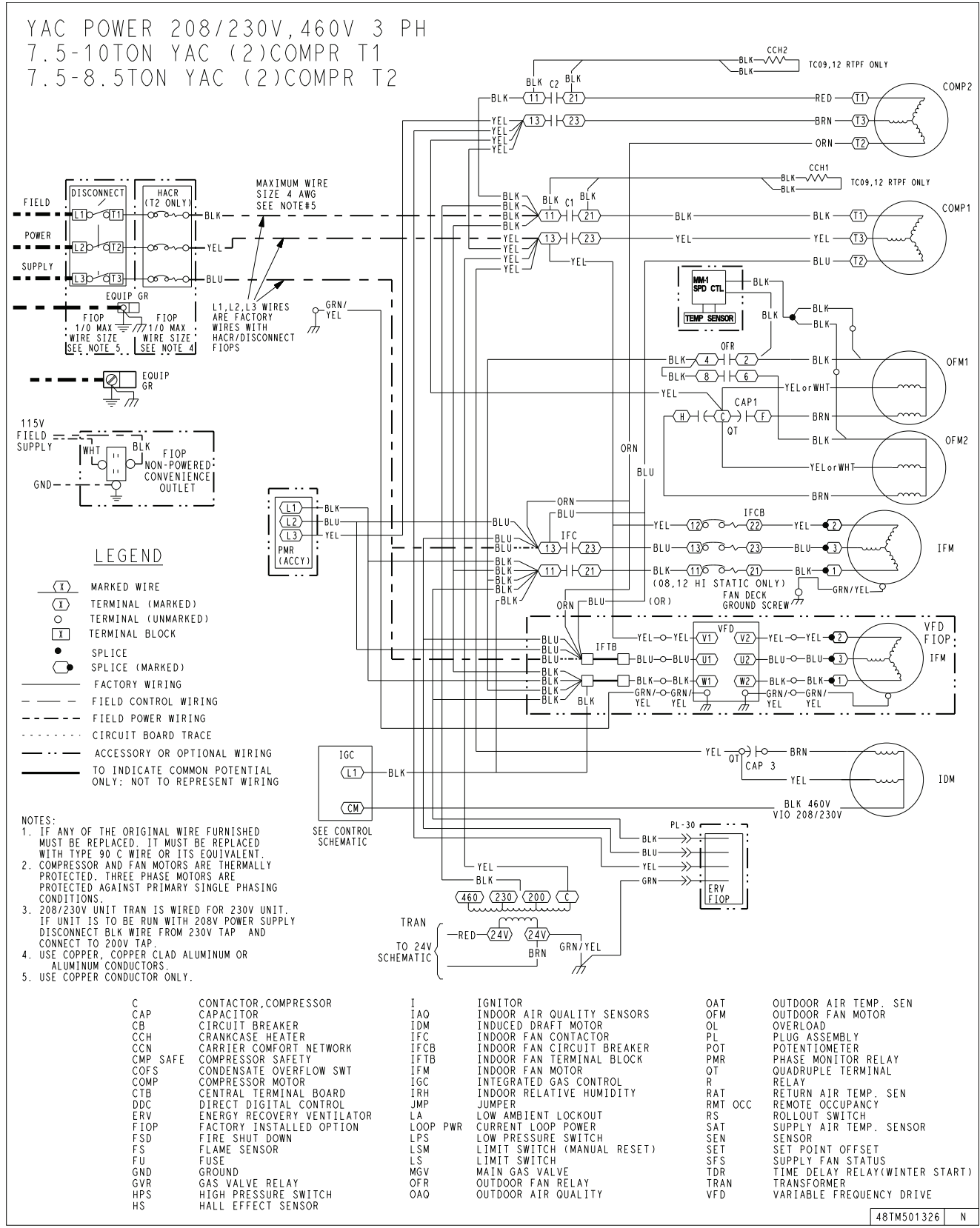

48HC 08, 09 TYPICAL CONTROL WIRING DIAGRAM

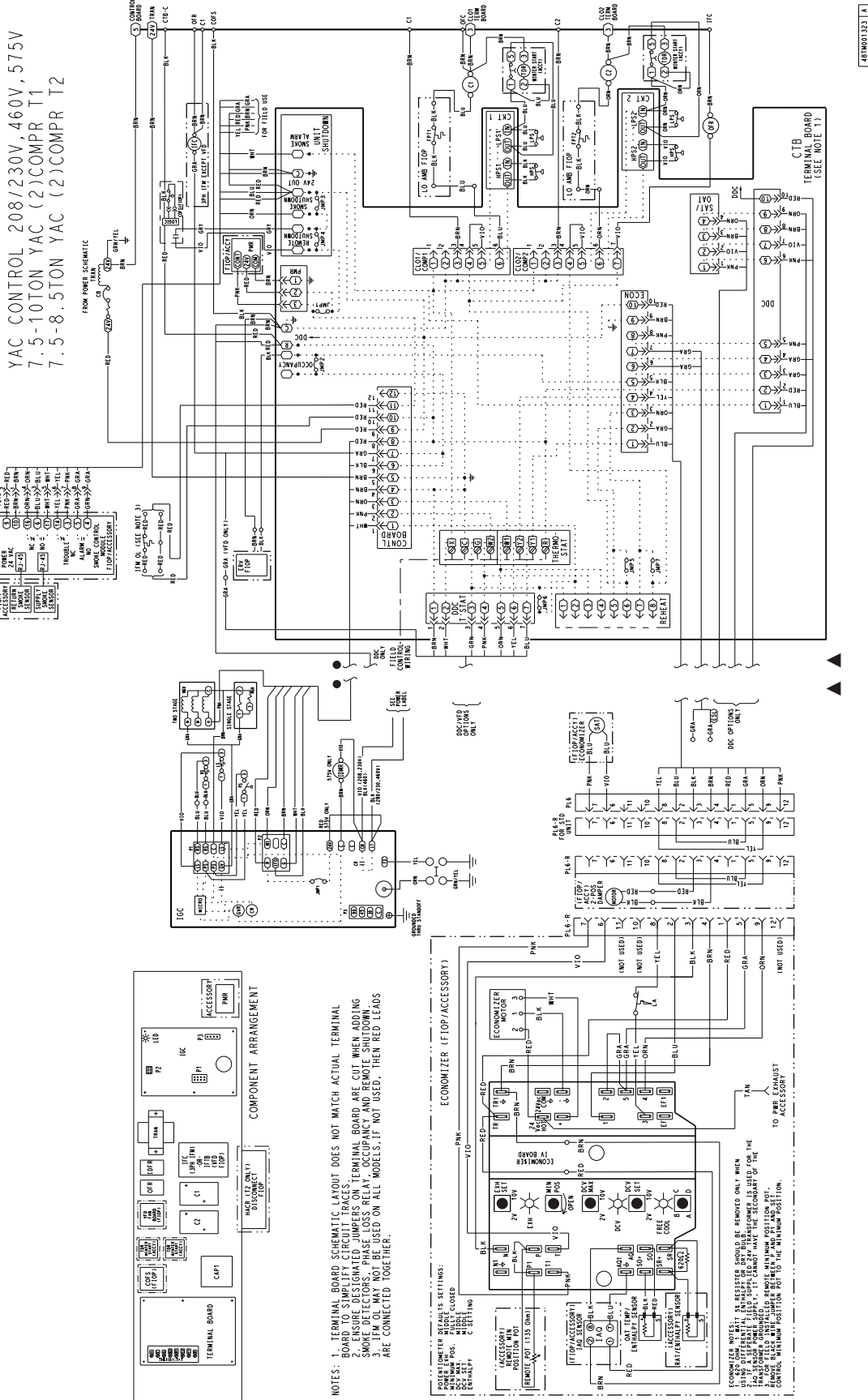



### 48HC 08, 09 TYPICAL POWER WIRING DIAGRAM, 208/230V AND 460V WITH OPTIONAL HUMIDI-MIZER® SYSTEM

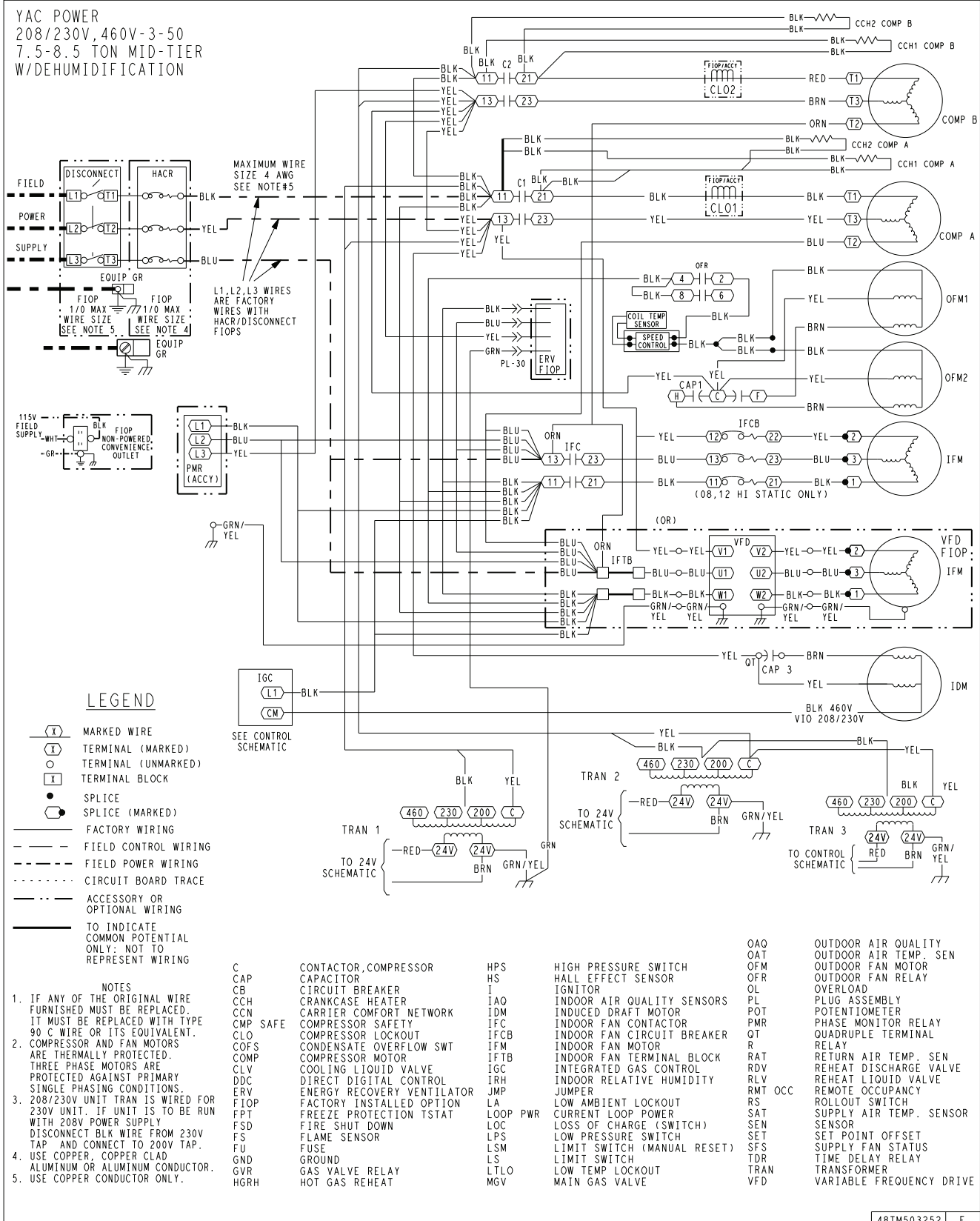

## 48HC 08, 09 CONTROL WIRING DIAGRAM WITH OPTIONAL HUMIDIFIER SYSTEM

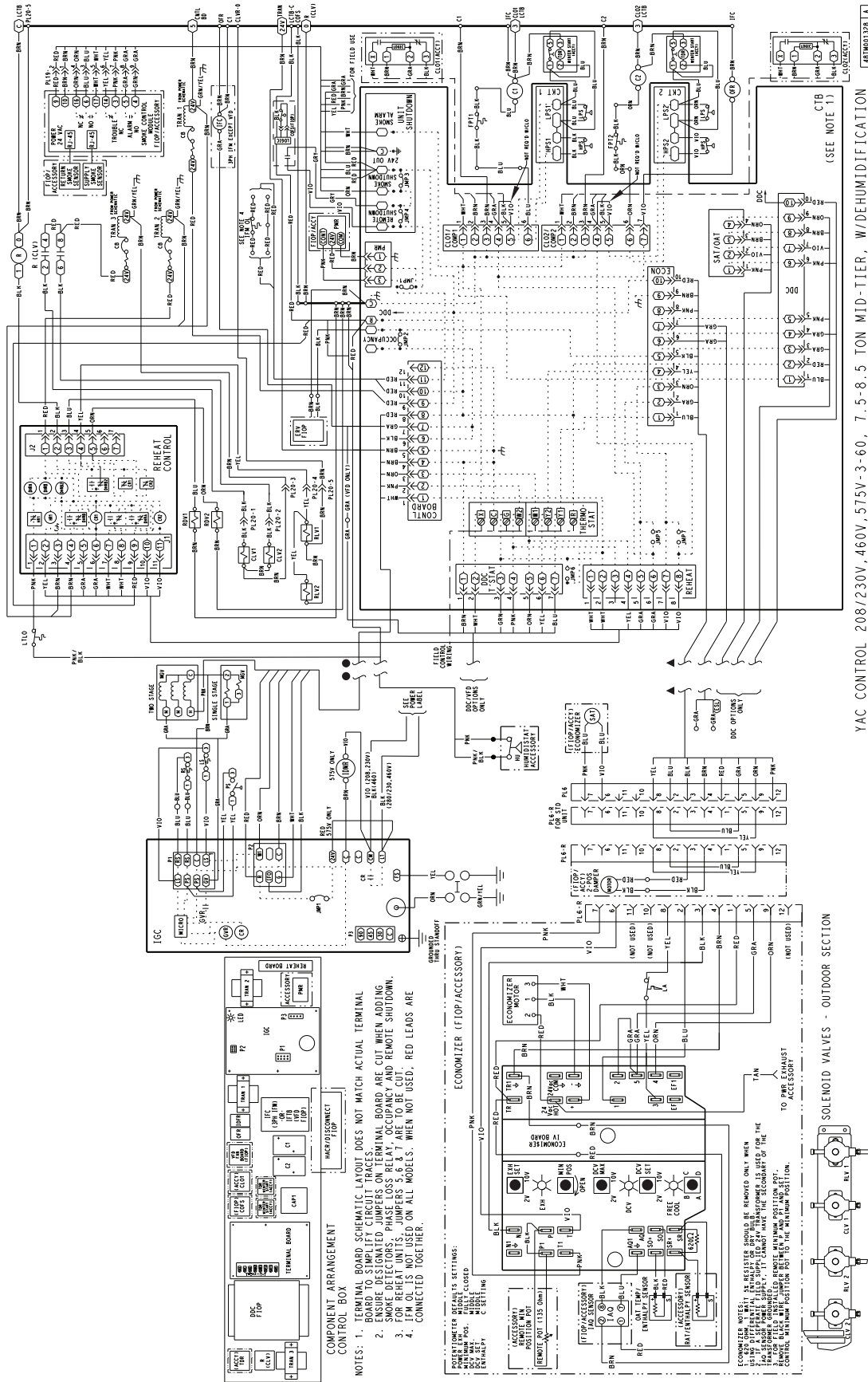

# 48HC MODULATING ERV WIRING SCHEMATIC

## ENERGY X HC

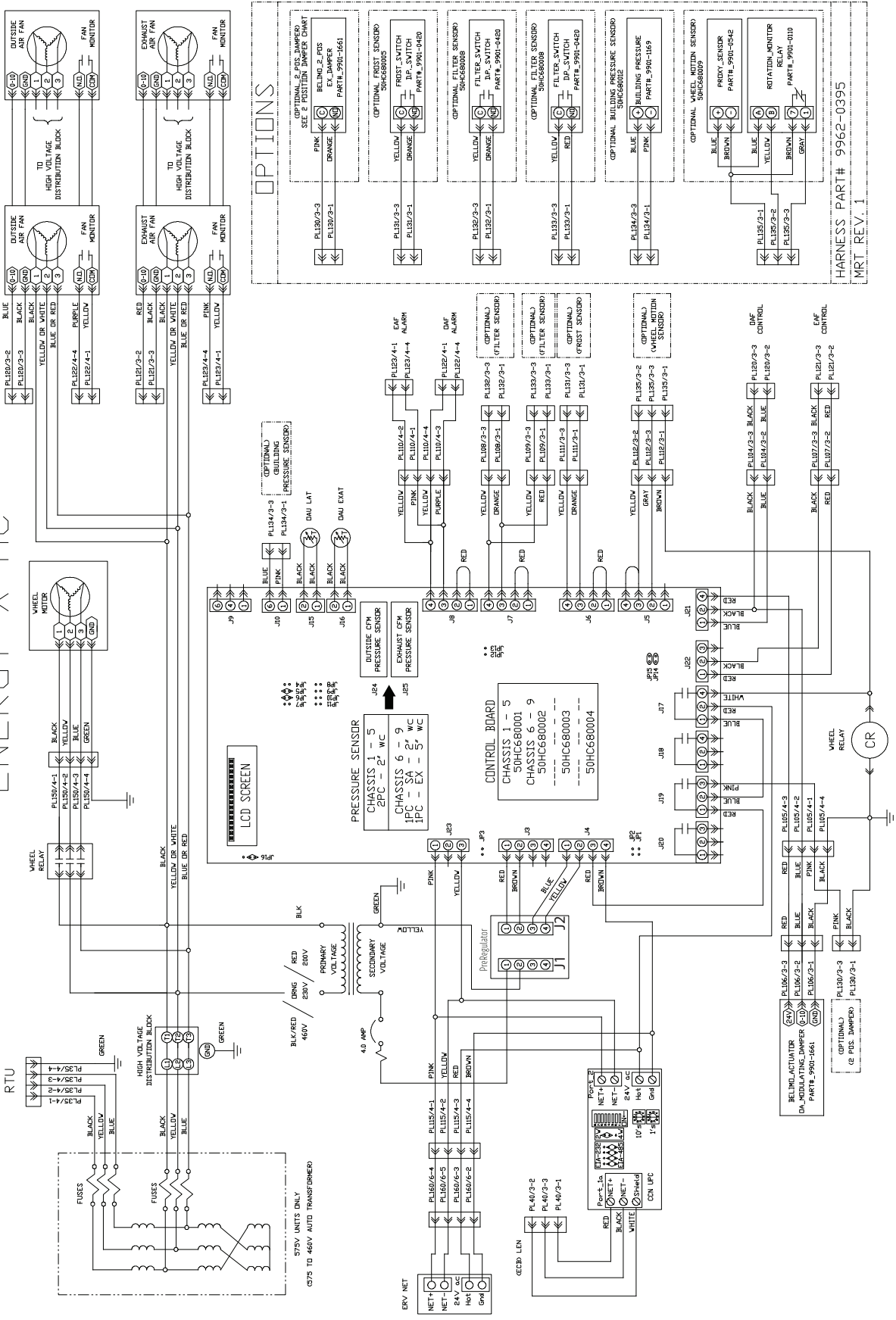

### OPTIONS

OPTIONAL FROST SENSOR  
 PLS10/4-3 PLS10/4-1  
 PLS10/4-3 PLS10/4-1

OPTIONAL FROST SENSOR  
 PLS10/4-3 PLS10/4-1  
 PLS10/4-3 PLS10/4-1

OPTIONAL FROST SENSOR  
 PLS10/4-3 PLS10/4-1  
 PLS10/4-3 PLS10/4-1

OPTIONAL BUILDING PRESSURE SENSOR  
 PLS10/4-3 PLS10/4-1  
 PLS10/4-3 PLS10/4-1

OPTIONAL WHEEL MOTOR SENSOR  
 PLS10/4-3 PLS10/4-1  
 PLS10/4-3 PLS10/4-1

HARNES PART# 9962-0395  
 MRT REV. 1

## 48HC\*A04-14 COOLING ELECTRICAL DATA

48HC UNIT*	V-PH-HZ	UNIT VOLTAGE		COMP 1		OFM (EA)		IFM			CMBST. FAN MOTOR	POWER EXHAUST	
		RANGE		RLA	LRA	WATTS	FLA	TYPE	EFFCY AT FULL LOAD	FLA		FLA	KIT QTY
		MIN	MAX										
04	208/230-1-60	187	253	16.6	79	190	1.0	DD-STD	78%	7.4	0.48	1	1.9
								STD	67%	4.9			
								MED	67%	4.9			
	208-3-60	187	253	10.4	73	190	1.0	DD-STD	78%	7.4	0.48	1	1.9
								STD	67%	4.9			
							MED	67%	4.9				
							HIGH	78%	7.4				
230-3-60	187	253	10.4	73	190	1.0	DD-STD	75%	5.2	0.48	1	1.9	
							STD	87%	5.2				
							MED	89%	8.4				
							HIGH	78%	7.4				
460-3-60	414	506	5.8	38	190	0.5	DD-STD	75%	5.2	0.25	1	1.0	
							STD	87%	4.9				
							MED	89%	8.3				
							HIGH	78%	4.0				
575-3-60	518	633	3.8	37	190	0.5	DD-STD	75%	2.6	0.24	1	1.9	
							STD	87%	2.5				
							MED	89%	4.2				
							HIGH	78%	4.0				
05	208/230-1-60	187	253	21.8	117	325	1.4	DD-STD	73%	1.2	0.48	1	1.9
								STD	73%	1.2			
								MED	78%	2.0			
	208-3-60	187	253	13.7	83	325	1.4	DD-STD	78%	7.4	0.48	1	1.9
								STD	67%	4.9			
							MED	67%	4.9				
							HIGH	78%	7.4				
230-3-60	187	253	13.7	83	325	1.4	DD-STD	67%	4.9	0.48	1	1.9	
							STD	67%	4.9				
							MED	78%	7.4				
							HIGH	75%	5.2				
460-3-60	414	506	6.2	41	325	0.9	DD-STD	87%	5.2	0.25	1	1.0	
							STD	89%	8.4				
							MED	78%	7.4				
							HIGH	75%	5.2				
575-3-60	518	633	4.8	33	325	0.9	DD-STD	87%	4.9	0.24	1	1.9	
							STD	89%	8.3				
							MED	78%	4.0				
							HIGH	75%	2.6				



**48HC\*A04-14 COOLING ELECTRICAL DATA (cont)**

48HC UNIT*	V-PH-HZ	UNIT VOLTAGE		COMP 1		OFM (EA)		IFM			CMBST. FAN MOTOR	POWER EXHAUST	
		RANGE		RLA	LRA	WATTS	FLA	TYPE	EFFCY AT FULL LOAD	FLA		FLA	KIT QTY
		MIN	MAX										
06	208/230-1-60	187	253	25.0	134	325	1.4	DD-STD	87%	2.5	0.48	1	1.9
								STD	89%	4.2			
								MED	78%	4.0			
	208-3-60	187	253	15.9	110	325	1.4	DD-STD	73%	1.2	0.48	1	1.9
								STD	72%	1.6			
							MED	77%	2.8				
							HIGH	78%	7.4				
230-3-60	187	253	15.9	110	325	1.4	DD-STD	67%	4.9	0.48	1	1.9	
							STD	76%	7.0				
							MED	78%	7.4				
							HIGH	67%	4.9				
460-3-60	414	506	7.0	52	325	0.9	DD-STD	76%	7.0	0.25	1	1.0	
							STD	78%	7.4				
							MED	75%	5.2				
							HIGH	89%	8.4				
575-3-60	518	633	5.1	40	325	0.9	DD-STD	89%	8.4	0.24	1	1.9	
							STD	78%	7.4				
							MED	75%	5.2				
							HIGH	89%	8.3				
A07	208-3-60	187	253	19.6	136	325	1.5	STD	75%	5.2	0.48	1	3.8
								MED	89%	8.4			
								HIGH	83%	13.6			
	208-3-60	187	253	19.6	136	325	1.5	STD	75%	5.2	0.48	1	3.8
							MED	89%	8.3				
							HIGH	83%	12.7				
460-3-60	414	506	8.2	66	325	0.8	STD	75%	2.6	0.25	1	1.8	
							MED	89%	4.2				
							HIGH	83%	6.4				
575-3-60	518	633	6.6	55	325	0.6	STD	72%	1.6	0.24	1	3.8	
							MED	77%	2.8				
							HIGH	81%	5.6				

## 48HC\*A04-14 COOLING ELECTRICAL DATA (cont)

48HC UNIT SIZE*	V-PH-HZ	UNIT VOLTAGE		COMP 1		COMP 2		OFM (EA)		IFM			CMBST FAN MOTOR	POWER EXHAUST	
		RANGE		RLA	LRA	RLA	LRA	WATTS	FLA	TYPE	EFFCY AT FULL LOAD	FLA		FLA	KIT QTY
		MIN	MAX												
D07	208-3-60	187	253	17.5	136	—	—	325	1.5	STD MED HIGH	75% 89% 83%	5.2 8.4 13.6	0.48	1	3.8
	230-3-60	187	253	17.5	136	—	—	325	1.5	STD MED HIGH	75% 89% 83%	5.2 8.3 12.7	0.48	1	3.8
	460-3-60	414	506	8.4	66	—	—	325	0.8	STD MED HIGH	75% 89% 83%	2.6 4.2 6.4	0.25	1	1.8
	575-3-60	518	633	6.3	55	—	—	325	0.6	STD MED HIGH	72% 77% 81%	1.6 2.8 5.6	0.24	1	3.8
08	208-3-60	187	253	13.6	83	13.6	83	325	1.5	STD MED HIGH	75% 87% 87%	5.2 6.9 10.6	0.48	1	3.8
	230-3-60	187	253	13.6	83	13.6	83	325	1.5	STD MED HIGH	75% 87% 87%	5.2 6.7 10.6	0.48	1	3.8
	460-3-60	414	506	6.1	41	6.1	41	325	0.8	STD MED HIGH	75% 87% 87%	2.6 3.4 5.3	0.25	1	1.8
	575-3-60	518	633	4.2	33	4.2	33	325	0.6	STD MED HIGH	72% 78% 77%	1.6 2.0 2.8	0.24	1	3.8
09	208-3-60	187	253	13.7	83	13.7	83	325	1.5	STD MED HIGH	75% 87% 87%	5.2 6.9 10.6	0.48	1	3.8
	230-3-60	187	253	13.7	83	13.7	83	325	1.5	STD MED HIGH	75% 87% 87%	5.2 6.7 10.6	0.48	1	3.8
	460-3-60	414	506	6.2	41	6.2	41	325	0.8	STD MED HIGH	75% 87% 87%	2.6 3.4 5.3	0.25	1	1.8
	575-3-60	518	633	4.8	33	4.8	33	325	0.6	STD MED HIGH	72% 78% 77%	1.6 2.0 2.8	0.24	1	3.8
11	208-3-60	187	253	15.9	110	15.9	110	610	7.4	STD MED HIGH	69% 87% 83%	5.2 10.6 13.6	0.48	1	3.8
	230-3-60	187	253	15.9	110	15.9	110	610	7.4	STD MED HIGH	69% 87% 83%	5.2 10.6 12.7	0.48	1	3.8
	460-3-60	414	506	7.0	52	7.0	52	610	3.6	STD MED HIGH	69% 87% 83%	2.6 5.3 6.4	0.25	1	1.8
	575-3-60	518	633	5.1	40	5.1	40	610	3.6	STD MED HIGH	78% 77% 81%	2.0 2.8 5.6	0.24	1	3.8



### 48HC\*A04-14 COOLING ELECTRICAL DATA (cont)

48HC UNIT SIZE*	V-PH-HZ	UNIT VOLTAGE		COMP 1		COMP 2		OFM (EA)		IFM			CMBST FAN MOTOR	POWER EXHAUST	
		RANGE		RLA	LRA	RLA	LRA	WATTS	FLA	TYPE	EFFCY AT FULL LOAD	FLA		FLA	KIT QTY
		MIN	MAX												
12	208-3-60	187	253	15.9	110	15.9	110	1070	6.2	STD MED HIGH	69% 87% 83%	5.2 10.6 13.6	0.48	1	3.8
	230-3-60	187	253	15.9	110	15.9	110	1070	6.2	STD MED HIGH	69% 87% 83%	5.2 10.6 12.7	0.48	1	3.8
	460-3-60	414	506	7.7	52	7.7	52	1070	3.1	STD MED HIGH	69% 87% 83%	2.6 5.3 6.4	0.25	1	1.8
	575-3-60	518	633	5.7	39	5.7	39	1070	2.5	STD MED HIGH	78% 77% 81%	2.0 2.8 5.6	0.24	1	3.8
14	208-3-60	187	253	19.6	136	19.6	136	280	1.5	STD MED HIGH HIGH-HE	79% 87% 87% 90%	7.5 10.6 17.0 20.4	0.48	1	3.8
	230-3-60	187	253	19.6	136	19.6	136	280	1.5	STD MED HIGH HIGH-HE	79% 87% 87% 90%	7.5 10.6 15.0 20.4	0.48	1	3.8
	460-3-60	414	506	8.2	66	8.2	66	280	0.8	STD MED HIGH HIGH-HE	79% 87% 87% 90%	3.4 5.3 7.6 10.2	0.25	1	1.8
	575-3-60	518	633	6.6	55	6.6	55	280	0.7	STD MED HIGH HIGH-HE	77% 77% 90% 94%	2.8 2.8 6.1 9.0	0.24	1	3.8

**LEGEND**

- COMP** — Compressor
- DD-STD** — Direct Drive Standard
- FLA** — Full Load Amps
- HIGH-HE** — High-High Efficiency
- IFM** — Indoor (Evaporator) Fan Motor
- LRA** — Locked Rotor Amps
- OFM** — Outdoor Fan Motor
- RLA** — Rated Load Amps

\* 48HC\*A04-48HC\*A07 — One-Stage Cooling  
 48HC\*D07-48HC\*D14 — Two-Stage Cooling

NOTE: Refer to Packaged Rooftop Builder (Selection Software) for additional electrical data.

## 48HC\*\*07-14 TWO-SPEED BLOWER COOLING ELECTRICAL DATA

48HC UNIT	V-PH-HZ	VOLTAGE		COMP 1		COMP 2		OFM (EA)		IFM			CMBST FAN MOTOR	PWR EXH		
		RANGE		RLA	LRA	RLA	LRA	WATTS	FLA	TYPE	EFF AT FULL LOAD	FLA		FLA	QTY	FLA
		MIN	MAX													
D07	208-3-60	187	253	17.5	136	—	—	325	1.5	STD	84%	5.8	0.48	1	3.8	
										MED	85%	8.6				
										HIGH	84%	13.6				
	230-3-60	187	253	17.5	136	—	—	325	1.5	STD	84%	5.6	0.48	1	3.8	
										MED	85%	7.8				
										HIGH	84%	12.7				
	460-3-60	414	506	8.4	66	—	—	325	0.8	STD	79%	2.9	0.25	1	1.8	
										MED	85%	3.8				
										HIGH	84%	6.4				
	575-3-60	518	633	6.3	55	—	—	325	0.6	STD	81%	2.8	0.24	1	3.8	
										MED	84%	4.5				
										HIGH	83%	6.2				
08	208-3-60	187	253	13.6	83	13.6	83	325	1.5	STD	84%	5.8	0.48	1	3.8	
										MED	77%	7.1				
										HIGH	82%	10.8				
	230-3-60	187	253	13.6	83	13.6	83	325	1.5	STD	84%	5.6	0.48	1	3.8	
										MED	77%	6.8				
										HIGH	82%	9.8				
	460-3-60	414	506	6.1	41	6.1	41	325	0.8	STD	79%	2.9	0.25	1	1.8	
										MED	77%	3.4				
										HIGH	82%	4.9				
	575-3-60	518	633	4.2	33	4.2	33	325	0.6	STD	81%	2.8	0.24	1	3.8	
										MED	80%	3.5				
										HIGH	84%	4.5				
09	208-3-60	187	253	13.7	83	13.7	83	325	1.5	STD	84%	5.8	0.48	1	3.8	
										MED	77%	7.1				
										HIGH	82%	10.8				
	230-3-60	187	253	13.7	83	13.7	83	325	1.5	STD	84%	5.6	0.48	1	3.8	
										MED	77%	6.8				
										HIGH	82%	9.8				
	460-3-60	414	506	6.2	41	6.2	41	325	0.8	STD	79%	2.9	0.25	1	1.8	
										MED	77%	3.4				
										HIGH	82%	4.9				
	575-3-60	518	633	4.8	33	4.8	33	325	0.6	STD	81%	2.8	0.24	1	3.8	
										MED	80%	3.5				
										HIGH	84%	4.5				





**48HC\*\*07-14 TWO-SPEED BLOWER COOLING ELECTRICAL DATA (cont)**

48HC UNIT	V-PH-HZ	VOLTAGE		COMP 1		COMP 2		OFM (EA)		IFM			CMBST FAN MOTOR	PWR EXH	
		RANGE		RLA	LRA	RLA	LRA	WATTS	FLA	TYPE	EFF AT FULL LOAD	FLA		FLA	QTY
		MIN	MAX												
11	208-3-60	187	253	15.9	110	15.9	110	610	7.4	STD	77%	7.1	0.48	1	3.8
										MED	82%	10.8			
										HIGH	84%	13.6			
	230-3-60	187	253	15.9	110	15.9	110	610	7.4	STD	77%	6.8	0.48	1	3.8
										MED	82%	9.8			
										HIGH	84%	12.7			
	460-3-60	414	506	7.0	52	7.0	52	610	3.6	STD	77%	3.4	0.25	1	1.8
										MED	82%	4.9			
										HIGH	84%	6.4			
	575-3-60	518	633	5.1	40	5.1	40	610	3.6	STD	80%	3.5	0.24	1	3.8
										MED	84%	4.5			
										HIGH	83%	6.2			
12	208-3-60	187	253	15.9	110	15.9	110	1070	6.2	STD	77%	7.1	0.48	1	3.8
										MED	82%	10.8			
										HIGH	84%	13.6			
	230-3-60	187	253	15.9	110	15.9	110	1070	6.2	STD	77%	6.8	0.48	1	3.8
										MED	82%	9.8			
										HIGH	84%	12.7			
	460-3-60	414	506	7.7	52	7.7	52	1070	3.1	STD	77%	3.4	0.25	1	1.8
										MED	82%	4.9			
										HIGH	84%	6.4			
	575-3-60	518	633	5.7	39	5.7	39	1070	2.5	STD	80%	3.5	0.24	1	3.8
										MED	84%	4.5			
										HIGH	83%	6.2			
14	208-3-60	187	253	19.6	136	19.6	136	280	1.5	STD	85%	8.6	0.48	1	3.8
										MED	82%	10.8			
										HIGH	90%	20.4			
	230-3-60	187	253	19.6	136	19.6	136	280	1.5	STD	85%	7.8	0.48	1	3.8
										MED	82%	9.8			
										HIGH	90%	20.4			
	460-3-60	414	506	8.2	66	8.2	66	280	0.8	STD	85%	3.8	0.25	1	1.8
										MED	82%	4.9			
										HIGH	90%	10.2			
	575-3-60	518	633	6.6	55	6.6	55	280	0.7	STD	84%	4.5	0.24	1	3.8
										MED	84%	4.5			
										HIGH	94%	9.0			

**LEGEND**

- FLA** — Full Load Amps
- IFM** — Indoor (Evaporator) Fan Motor
- LRA** — Locked Rotor Amps
- RLA** — Rated Load Amps

NOTE: Refer to Packaged Rooftop Builder (Selection Software) for additional electrical data.

## 48HC\*\*04-14 MCA MOCP ELECTRICAL DATA

48HC UNIT SIZE*	NOM. V-PH-HZ	IFM TYPE	NO CONVENIENCE OUTLET OR UNPOWERED CONVENIENCE OUTLET								WITH POWERED CONVENIENCE OUTLET							
			NO P.E.				WITH P.E. (PWRD FR/UNIT)				NO P.E.				WITH P.E. (PWRD FR/UNIT)			
			MCA	FUSE OR HACR BRKR	DISC. SIZE		MCA	FUSE OR HACR BRKR	DISC. SIZE		MCA	HACR BRKR	DISC. SIZE		MCA	HACR BRKR	DISC. SIZE	
					FLA	LRA			FLA	LRA			FLA	LRA			FLA	LRA
A04	208/230-1-60	DD-STD	30	45	29	88	32	45	31	90	34	50	34	93	36	50	36	95
		STD	27	40	26	93	29	45	28	95	32	45	31	98	34	45	34	100
		MED	27	40	26	93	29	45	28	95	32	45	31	98	34	45	34	100
	208/230-3-60	DD-STD	22	30	22	82	24	30	24	84	27	30	27	87	29	35	29	89
		STD	20	25	19	94	22	30	21	96	24	30	25	99	26	30	27	101
		MED	20/19	25/25	19/19	111	22/21	30/30	21/21	113	24/24	30/30	25/24	116	26/26	30/30	27/26	118
	460-3-60	HIGH	23/23	30/30	23/23	147	25/25	30/30	25/25	149	28/28	30/30	28/28	152	30/29	35/35	30/30	154
		DD-STD	12	15	12	43	13	15	13	44	14	20	14	45	15	20	16	46
		STD	11	15	10	48	12	15	11	49	13	15	13	50	14	20	14	51
		MED	11	15	10	57	12	15	11	58	13	15	13	59	14	15	14	60
	575-3-60	HIGH	12	15	12	75	13	15	13	76	15	20	15	77	16	20	16	78
		DD-STD	10	15	10	42	12	15	12	44	11	15	12	44	13	15	14	46
STD		7	15	6	45	9	15	9	47	9	15	8	47	11	15	10	49	
MED		7	15	6	45	9	15	9	47	9	15	8	47	11	15	10	49	
A05	208/230-1-60	HIGH	8	15	7	49	10	15	9	51	9	15	9	51	11	15	11	53
		DD-STD	37	50	35	127	38	50	37	129	41	60	41	132	43	60	43	134
		STD	34	50	32	132	36	50	35	134	39	60	38	137	41	60	40	139
	208/230-3-60	MED	34	50	32	132	36	50	35	134	39	60	38	137	41	60	40	139
		DD-STD	26	30	26	93	28	40	28	95	31	40	31	98	33	45	34	100
		STD	24	30	23	105	26	30	26	107	29	40	29	110	31	40	31	112
	460-3-60	MED	24/24	30/30	23/23	122	26/26	30/30	26/25	124	29/29	40/40	29/29	127	31/31	40/40	31/31	129
		HIGH	27/27	40/40	27/27	158	29/29	40/40	29/29	160	32/32	45/45	33/32	163	34/34	45/45	35/35	165
		DD-STD	13	15	13	47	14	20	14	48	15	20	15	49	16	20	16	50
		STD	12	15	11	52	13	15	12	53	14	20	14	54	15	20	15	55
	575-3-60	MED	12	15	11	61	13	15	12	62	14	15	14	63	15	20	15	64
		HIGH	13	15	13	79	14	20	14	80	16	20	16	81	17	20	17	82
DD-STD		11	15	11	39	13	15	13	41	13	15	13	41	15	20	15	43	
STD		9	15	8	42	10	15	10	44	10	15	10	44	12	15	12	46	
A06	208/230-1-60	MED	9	15	8	42	11	15	11	44	11	15	10	44	13	15	13	46
		HIGH	10	15	10	57	12	15	12	59	12	15	12	59	14	15	14	61
		DD-STD	41	60	39	144	42	60	41	146	45	60	44	149	47	60	47	151
	208/230-3-60	STD	38	60	36	149	40	60	38	151	43	60	42	154	45	60	44	156
		MED	40	60	38	174	42	60	41	176	45	60	44	179	47	60	46	181
		DD-STD	29	40	28	120	31	45	31	122	34	45	34	125	36	50	36	127
	460-3-60	STD	27	40	26	132	29	40	28	134	32	45	31	137	34	45	34	139
		MED	30/30	45/45	30/29	185	32/32	45/45	32/32	187	35/35	50/50	35/35	190	37/37	50/50	37/37	192
		HIGH	30/30	45/45	30/29	185	32/32	45/45	32/32	187	35/35	50/50	35/35	190	37/37	50/50	37/37	192
		DD-STD	14	20	14	58	15	20	15	59	16	20	16	60	17	20	17	61
	575-3-60	STD	13	15	12	63	14	20	13	64	15	20	15	65	16	20	16	66
		MED	14	20	14	90	15	20	15	91	17	20	16	92	18	20	18	93
HIGH		14	20	14	90	15	20	15	91	17	20	16	92	18	20	18	93	
DD-STD		12	15	12	46	14	15	14	48	13	15	13	48	15	20	16	50	
575-3-60	STD	9	15	8	49	11	15	10	51	11	15	10	51	13	15	12	53	
	MED	10	15	9	53	12	15	11	55	11	15	11	55	13	15	13	57	
	HIGH	11	15	10	64	12	15	12	66	12	15	12	66	14	15	14	68	

**48HC\*\*04-14 MCA MOCPE ELECTRICAL DATA (cont)**

48HC UNIT SIZE*	NOM. V-PH-HZ	IFM TYPE	NO CONVENIENCE OUTLET OR UNPOWERED CONVENIENCE OUTLET								WITH POWERED CONVENIENCE OUTLET							
			NO P.E.				WITH P.E. (PWRD FR/UNIT)				NO P.E.				WITH P.E. (PWRD FR/UNIT)			
			MCA	FUSE OR HACR BRKR	DISC. SIZE		MCA	FUSE OR HACR BRKR	DISC. SIZE		MCA	HACR BRKR	DISC. SIZE		MCA	HACR BRKR	DISC. SIZE	
					FLA	LRA			FLA	LRA			FLA	LRA			FLA	LRA
A07	208/230-3-60	STD	33	50	32	161	37	50	36	165	38	50	37	166	42	60	42	170
		MED	36/36	50/50	36/36	214	40/40	50/50	40/40	218	41/41	60/60	41/41	219	45/45	60/60	46/45	223
		HIGH	42/41	60/50	42/41	230	45/44	60/60	46/45	234	46/45	60/60	47/46	235	50/49	60/60	52/50	239
	460-3-60	STD	15	20	14	79	17	20	16	81	17	20	17	81	19	25	19	83
		MED	17	20	16	106	18	25	18	108	19	25	19	108	21	25	21	110
		HIGH	19	25	19	114	21	25	21	116	21	25	21	116	23	30	23	118
	575-3-60	STD	12	15	11	66	15	20	15	70	13	15	13	68	17	20	17	72
		MED	13	15	12	81	17	20	17	85	14	20	14	83	18	20	19	87
		HIGH	16	20	15	95	19	25	20	99	17	20	17	97	21	25	22	101
D07	208/230-3-60	STD	31	45	30	161	34	50	34	165	35	50	35	166	39	50	39	170
		MED	34/34	50/50	33/33	214	38/37	50/50	38/37	218	39/38	50/50	39/39	219	42/42	50/50	43/43	223
		HIGH	39/38	50/50	39/38	230	43/42	50/50	44/43	234	44/43	60/50	45/44	235	48/47	60/60	49/48	239
	460-3-60	STD	15	20	14	79	17	20	17	81	17	25	17	81	19	25	19	83
		MED	17	20	16	106	19	25	18	108	19	25	19	108	21	25	21	110
		HIGH	19	25	19	114	21	25	21	116	21	25	21	116	23	30	23	118
	575-3-60	STD	11	15	10	66	15	20	15	70	13	15	12	68	17	20	17	72
		MED	12	15	12	81	16	20	16	85	14	20	14	83	18	20	18	87
		HIGH	15	20	15	95	19	25	19	99	17	20	17	97	21	25	21	101
D08	208/230-3-60	STD	39	50	41	191	43	50	45	195	44	50	46	196	48	60	51	200
		MED	41/41	50/50	43/42	229	45/45	50/50	47/47	233	46/46	50/50	48/48	234	50/49	60/60	53/52	238
		HIGH	45	50	47	258	48	60	51	262	49	60	52	263	53	60	57	267
	460-3-60	STD	18	20	19	95	20	25	21	97	21	25	21	97	22	25	23	99
		MED	19	25	20	114	21	25	22	116	21	25	22	116	23	25	24	118
		HIGH	21	25	22	129	23	25	24	131	23	25	24	131	25	30	27	133
	575-3-60	STD	13	15	13	77	17	20	17	81	14	15	15	79	18	20	19	83
		MED	13	15	13	81	17	20	18	85	15	20	15	83	19	20	20	87
		HIGH	14	15	14	92	18	20	19	96	16	20	16	94	19	25	21	98
D09	208/230-3-60	STD	39	50	41	191	43	50	45	195	44	50	46	196	48	60	51	200
		MED	41/41	50/50	43/43	229	45/45	50/50	47/47	233	46/46	50/50	48/48	234	50/50	60/60	53/53	238
		HIGH	45	50	47	258	49	60	52	262	50	60	53	263	53	60	57	267
	460-3-60	STD	19	20	19	95	20	25	21	97	21	25	22	97	23	25	24	99
		MED	19	25	20	114	21	25	22	116	22	25	23	116	23	25	25	118
		HIGH	21	25	22	129	23	25	24	131	24	25	25	131	25	30	27	133
	575-3-60	STD	14	15	14	77	18	20	19	81	16	20	16	79	20	25	21	83
		MED	14	20	15	81	18	20	19	85	16	20	17	83	20	25	21	87
		HIGH	15	20	16	92	19	20	20	96	17	20	18	94	21	25	22	98
D11	208/230-3-60	STD	49	60	51	257	53	60	55	261	54	60	57	262	57	70	61	266
		MED	54	60	57	313	58	70	62	317	59	70	63	318	63	70	67	322
		HIGH	57/56	70/60	61/60	315	61/60	70/70	65/64	319	62/61	70/70	66/65	320	66/65	80/80	71/70	324
	460-3-60	STD	22	25	23	123	24	30	25	125	25	30	26	125	26	30	28	127
		MED	25	30	26	151	27	30	28	153	27	30	29	153	29	35	31	155
		HIGH	26	30	28	152	28	30	30	154	28	30	30	154	30	35	32	156
	575-3-60	STD	18	20	18	95	21	25	23	99	19	25	20	97	23	25	24	101
		MED	18	20	19	106	22	25	23	110	20	25	21	108	24	25	25	112
		HIGH	21	25	22	120	25	30	27	124	23	25	24	122	27	30	29	126

## 48HC\*\*04-14 MCA MOCP ELECTRICAL DATA (cont)

48HC UNIT SIZE*	NOM. V-PH-HZ	IFM TYPE	NO CONVENIENCE OUTLET OR UNPOWERED CONVENIENCE OUTLET								WITH POWERED CONVENIENCE OUTLET							
			NO P.E.				WITH P.E. (PWRD FR/UNIT)				NO P.E.				WITH P.E. (PWRD FR/UNIT)			
			MCA	FUSE OR HACR BRKR	DISC. SIZE		MCA	FUSE OR HACR BRKR	DISC. SIZE		MCA	HACR BRKR	DISC. SIZE		MCA	HACR BRKR	DISC. SIZE	
					FLA	LRA			FLA	LRA			FLA	LRA			FLA	LRA
D12	208/230-3-60	STD	48	60	50	282	51	60	54	286	52	60	55	287	56	60	60	291
		MED	53	60	56	338	57	70	60	342	58	70	61	343	62	70	66	347
		HIGH	56/55	60/60	59/58	340	60/59	70/70	64/63	344	61/60	70/70	65/64	345	65/64	80/70	69/68	349
	460-3-60	STD	23	30	24	135	25	30	26	137	26	30	27	137	27	30	29	139
		MED	26	30	27	163	28	30	29	165	28	30	30	165	30	35	32	167
		HIGH	27	30	29	164	29	35	31	166	29	35	31	166	31	35	33	168
	575-3-60	STD	18	20	18	105	22	25	23	109	19	25	20	107	23	25	25	111
		MED	19	20	19	116	22	25	24	120	20	25	21	118	24	30	26	122
		HIGH	21	25	22	130	25	30	27	134	23	25	24	132	27	30	29	136
D14	208/230-3-60	STD	57	70	59	340	60	70	63	344	61	80	64	345	65	80	69	349
		MED	60	70	62	370	63	80	67	374	64	80	68	375	68	80	72	379
		HIGH	66/64	80/80	70/68	368	70/68	80/80	74/72	372	71/69	80/80	75/73	373	75/73	80/80	80/77	377
		HIGH-HE	70	80	74	376	73	80	78	380	74	80	79	381	78	90	84	385
	460-3-60	STD	25	30	26	166	27	30	28	168	27	30	28	168	29	35	30	170
		MED	27	30	28	181	28	35	30	183	29	35	30	183	31	35	32	185
		HIGH	29	35	30	180	31	35	32	182	31	35	33	182	33	40	35	184
		HIGH-HE	32	40	33	184	34	40	35	186	34	40	36	186	36	45	38	188
	575-3-60	STD	20	25	21	138	24	30	25	142	22	25	23	140	26	30	27	144
		MED	20	25	21	138	24	30	25	142	22	25	23	140	26	30	27	144
		HIGH	24	25	25	141	27	30	29	145	25	30	27	143	29	35	31	147
		HIGH-HE	27	30	28	150	31	35	32	154	29	35	30	152	33	40	34	156

**LEGEND**

- FLA** — Full Load Amps
- IFM** — Indoor (Evaporator) Fan Motor
- HIGH-HE** — High-High Efficiency
- LRA** — Locked Rotor Amps
- MCA** — Minimum Circuit Amps

\* 48HC\*A04-48HC\*A07 — One-Stage Cooling  
 48HC\*D07-48HC\*D14 — Two-Stage Cooling

NOTE: Refer to Packaged Rooftop Builder (Selection Software) for additional electrical data.







# Electrical data (cont)



## 48HC\*\*04-14 WITH ERV AND FACTORY INSTALLED HACR BREAKER MCA MOCP ELECTRICAL DATA (cont)

48HC UNIT SIZE*	NOM. V-PH-HZ	IFM TYPE	NO C.O. OR UNPWR C.O.								W/ PWRD C.O.							
			W/ERV W/O ECONOMIZER				W/ERV W/ECONOMIZER				W/ERV W/O ECONOMIZER				W/ERV W/ECONOMIZER			
			MCA	HACR BRKR	DISC. SIZE		MCA	HACR BRKR	DISC. SIZE		MCA	HACR BRKR	DISC. SIZE		MCA	HACR BRKR	DISC. SIZE	
					FLA	LRA			FLA	LRA			FLA	LRA			FLA	LRA
D08	208/230-3-60	STD	51	60	54	203	51	60	54	203	56	60	60	208	56	60	60	208
		MED	53/53	60/60	56/56	241	53/53	60/60	56/56	241	58/58	70/70	62/62	246	58/58	70/70	62/62	246
		HIGH	57	60	61	270	57	60	61	270	61	70	66	275	61	70	66	275
	460-3-60	STD	24	25	25	101	24	25	25	101	26	30	28	103	26	30	28	103
		MED	25	30	26	120	25	30	26	120	27	30	29	122	27	30	29	122
		HIGH	27	30	28	135	27	30	28	135	29	30	31	137	29	30	31	137
	575-3-60	STD	18	20	19	83	18	20	19	83	20	25	21	85	20	25	21	85
		MED	19	20	20	87	19	20	20	87	20	25	22	89	20	25	22	89
		HIGH	19	20	21	98	19	20	21	98	21	25	22	100	21	25	22	100
D09	208/230-3-60	STD	51	60	55	203	51	60	55	203	56	60	60	208	56	60	60	208
		MED	53/53	60/60	57/56	241	53/53	60/60	57/56	241	58/58	70/70	62/62	246	58/58	70/70	62/62	246
		HIGH	57	60	61	270	57	60	61	270	62	70	66	275	62	70	66	275
	460-3-60	STD	24	30	25	101	24	30	25	101	26	30	28	103	26	30	28	103
		MED	25	30	26	120	25	30	26	120	27	30	29	122	27	30	29	122
		HIGH	27	30	28	135	27	30	28	135	29	35	31	137	29	35	31	137
	575-3-60	STD	20	25	21	83	20	25	21	83	21	25	22	85	21	25	22	85
		MED	20	25	21	87	20	25	21	87	22	25	23	89	22	25	23	89
		HIGH	21	25	22	98	21	25	22	98	22	25	24	100	22	25	24	100
D11	208/230-3-60	STD	61	70	65	269	61	70	65	269	66	80	70	274	66	80	70	274
		MED	66	80	71	325	66	80	71	325	71	80	77	330	71	80	77	330
		HIGH	69/69	80/80	74/73	327	69/69	80/80	74/73	327	74/74	80/80	80/79	332	74/74	80/80	80/79	332
	460-3-60	STD	28	30	29	129	28	30	29	129	30	35	32	131	30	35	32	131
		MED	31	35	33	157	31	35	33	157	33	35	35	159	33	35	35	159
		HIGH	32	35	34	158	32	35	34	158	34	40	36	160	34	40	36	160
	575-3-60	STD	23	25	24	101	23	25	24	101	25	30	26	103	25	30	26	103
		MED	24	25	25	112	24	25	25	112	25	30	27	114	25	30	27	114
		HIGH	27	30	29	126	27	30	29	126	28	30	31	128	28	30	31	128
D12	208/230-3-60	STD	60	70	63	294	60	70	63	294	64	70	69	299	64	70	69	299
		MED	65	80	70	350	65	80	70	350	70	80	75	355	70	80	75	355
		HIGH	68/68	80/80	73/72	352	68/68	80/80	73/72	352	73/73	80/80	79/78	357	73/73	80/80	79/78	357
	460-3-60	STD	29	35	31	141	29	35	31	141	31	35	33	143	31	35	33	143
		MED	32	35	34	169	32	35	34	169	34	40	36	171	34	40	36	171
		HIGH	33	35	35	170	33	35	35	170	35	40	37	172	35	40	37	172
	575-3-60	STD	23	25	25	111	23	25	25	111	25	30	27	113	25	30	27	113
		MED	24	30	25	122	24	30	25	122	26	30	27	124	26	30	27	124
		HIGH	27	30	29	136	27	30	29	136	29	30	31	138	29	30	31	138
D14	208/230-3-60	STD	73	80	77	356	73	80	77	356	78	90	83	361	78	90	83	361
		MED	76	90	81	386	76	90	81	386	81	90	87	391	81	90	87	391
		HIGH	82/82	100/100	88/86	384	82/82	100/100	88/86	384	87/87	100/100	94/92	389	87/87	100/100	94/92	389
	460-3-60	HIGH-HE	86	100	92	392	86	100	92	392	91	100	98	397	91	100	98	397
		STD	32	35	34	173	32	35	34	173	34	40	36	175	34	40	36	175
		MED	34	40	36	188	34	40	36	188	36	40	38	190	36	40	38	190
		HIGH	36	40	38	187	36	40	38	187	38	45	41	189	38	45	41	189
	575-3-60	HIGH-HE	39	45	41	191	39	45	41	191	41	50	44	193	41	50	44	193
		STD	27	30	29	145	27	30	29	145	29	35	31	147	29	35	31	147
MED		27	30	29	145	27	30	29	145	29	35	31	147	29	35	31	147	
HIGH		31	35	33	148	31	35	33	148	32	35	35	150	32	35	35	150	
HIGH-HE	34	40	36	157	34	40	36	157	36	40	38	159	36	40	38	159		





**48HC\*\*04-14 WITH ERV AND 2-SPEED INDOOR BLOWER OPTION MCA MOCP ELECTRICAL DATA**

48HC UNIT SIZE*	NOM. V-PH-HZ	IFM TYPE	NO C.O. OR UNPWR C.O.								W/ PWRD C.O.							
			W/ERV W/O ECONOMIZER				W/ERV W/ECONOMIZER				W/ERV W/O ECONOMIZER				W/ERV W/ECONOMIZER			
			MCA	FUSE OR HACR BRKR	DISC. SIZE		MCA	FUSE OR HACR BRKR	DISC. SIZE		MCA	FUSE OR HACR BRKR	DISC. SIZE		MCA	FUSE OR HACR BRKR	DISC. SIZE	
					FLA	LRA			FLA	LRA			FLA	LRA			FLA	LRA
D07	208/230-3-60	STD	39/39	50/50	40/39	173	39/39	50/50	40/39	173	44/44	60/60	45/45	178	44/44	60/60	45/45	178
		MED	42/41	50/50	43/42	203	42/41	50/50	43/42	203	47/46	60/60	48/47	208	47/46	60/60	48/47	208
		HIGH	47/46	60/60	49/47	238	47/46	60/60	49/47	238	52/51	60/60	54/53	243	52/51	60/60	54/53	243
	460-3-60	STD	19	25	19	85	19	25	19	85	21	25	22	87	21	25	22	87
		MED	20	25	20	101	20	25	20	101	22	30	23	103	22	30	23	103
		HIGH	23	30	23	118	23	30	23	118	25	30	26	120	25	30	26	120
	575-3-60	STD	16	20	16	72	16	20	16	72	18	20	18	74	18	20	18	74
		MED	18	20	18	85	18	20	18	85	20	25	20	87	20	25	20	87
		HIGH	20	25	20	99	20	25	20	99	21	25	22	101	21	25	22	101
D08	208/230-3-60	STD	52/52	60/60	55/55	207	52/52	60/60	55/55	207	57/56	60/60	61/60	212	57/56	60/60	61/60	212
		MED	53/53	60/60	57/56	211	53/53	60/60	57/56	211	58/58	70/70	62/62	216	58/58	70/70	62/62	216
		HIGH	57/56	60/60	61/60	261	57/56	60/60	61/60	261	62/61	70/70	66/65	266	62/61	70/70	66/65	266
	460-3-60	STD	24	30	25	103	24	30	25	103	26	30	28	105	26	30	28	105
		MED	25	30	26	106	25	30	26	106	27	30	29	108	27	30	29	108
		HIGH	26	30	28	131	26	30	28	131	28	30	30	133	28	30	30	133
	575-3-60	STD	19	20	21	85	19	20	21	85	21	25	22	87	21	25	22	87
		MED	20	25	21	89	20	25	21	89	22	25	23	91	22	25	23	91
		HIGH	21	25	22	98	21	25	22	98	23	25	24	100	23	25	24	100
D09	208/230-3-60	STD	52/52	60/60	55/55	207	52/52	60/60	55/55	207	57/57	60/60	61/61	212	57/57	60/60	61/61	212
		MED	53/53	60/60	57/57	211	53/53	60/60	57/57	211	58/58	70/70	62/62	216	58/58	70/70	62/62	216
		HIGH	57/56	70/60	61/60	261	57/56	70/60	61/60	261	62/61	70/70	67/66	266	62/61	70/70	67/66	266
	460-3-60	STD	24	30	26	103	24	30	26	103	27	30	28	105	27	30	28	105
		MED	25	30	26	106	25	30	26	106	27	30	29	108	27	30	29	108
		HIGH	26	30	28	131	26	30	28	131	29	30	31	133	29	30	31	133
	575-3-60	STD	21	25	22	85	21	25	22	85	22	25	24	87	22	25	24	87
		MED	21	25	23	89	21	25	23	89	23	25	25	91	23	25	25	91
		HIGH	22	25	24	98	22	25	24	98	24	25	26	100	24	25	26	100
D11	208/230-3-60	STD	63/62	70/70	67/67	266	63/62	70/70	67/67	266	67/67	80/80	73/72	271	67/67	80/80	73/72	271
		MED	66/65	80/80	71/70	316	66/65	80/80	71/70	316	71/70	80/80	77/76	321	71/70	80/80	77/76	321
		HIGH	69/68	80/80	74/73	327	69/68	80/80	74/73	327	74/73	80/80	80/79	332	74/73	80/80	80/79	332
	460-3-60	STD	29	30	30	128	29	30	30	128	31	35	33	130	31	35	33	130
		MED	30	35	32	153	30	35	32	153	32	35	35	155	32	35	35	155
		HIGH	32	35	34	158	32	35	34	158	34	40	36	160	34	40	36	160
	575-3-60	STD	24	30	26	103	24	30	26	103	26	30	28	105	26	30	28	105
		MED	25	30	27	112	25	30	27	112	27	30	29	114	27	30	29	114
		HIGH	27	30	29	126	27	30	29	126	29	35	31	128	29	35	31	128

# Electrical data (cont)



## 48HC\*\*04-14 WITH ERV AND 2-SPEED INDOOR BLOWER OPTION MCA MOCP ELECTRICAL DATA (cont)

48HC UNIT SIZE*	NOM. V-PH-HZ	IFM TYPE	NO C.O. OR UNPWR C.O.								W/ PWRD C.O.							
			W/ERV W/O ECONOMIZER				W/ERV W/ECONOMIZER				W/ERV W/O ECONOMIZER				W/ERV W/ECONOMIZER			
			MCA	FUSE OR HACR BRKR	DISC. SIZE		MCA	FUSE OR HACR BRKR	DISC. SIZE		MCA	FUSE OR HACR BRKR	DISC. SIZE		MCA	FUSE OR HACR BRKR	DISC. SIZE	
					FLA	LRA			FLA	LRA			FLA	LRA			FLA	LRA
D12	208/230-3-60	STD	61/61	70/70	66/65	291	61/61	70/70	66/65	291	66/66	80/80	71/71	296	66/66	80/80	71/71	296
		MED	65/64	80/70	70/69	341	65/64	80/70	70/69	341	70/69	80/80	75/74	346	70/69	80/80	75/74	346
		HIGH	68/67	80/80	73/72	352	68/67	80/80	73/72	352	73/72	80/80	79/78	357	73/72	80/80	79/78	357
	460-3-60	STD	30	35	31	140	30	35	31	140	32	35	34	142	32	35	34	142
		MED	31	35	33	165	31	35	33	165	33	40	36	167	33	40	36	167
		HIGH	33	35	35	170	33	35	35	170	35	40	37	172	35	40	37	172
	575-3-60	STD	25	30	26	113	25	30	26	113	26	30	28	115	26	30	28	115
		MED	26	30	27	122	26	30	27	122	27	30	29	124	27	30	29	124
		HIGH	28	30	29	136	28	30	29	136	29	35	31	138	29	35	31	138
D14	208/230-3-60	STD	74/73	80/80	79/78	353	74/73	80/80	79/78	353	79/78	90/90	84/83	358	79/78	90/90	84/83	358
		MED	76/75	90/80	81/80	377	76/75	90/80	81/80	377	81/80	90/90	87/86	382	81/80	90/90	87/86	382
		HIGH	86	100	92	392	86	100	92	392	91	100	98	397	91	100	98	397
	460-3-60	STD	32	35	34	172	32	35	34	172	34	40	37	174	34	40	37	174
		MED	33	40	35	184	33	40	35	184	35	40	38	186	35	40	38	186
		HIGH	39	45	41	191	39	45	41	191	41	50	44	193	41	50	44	193
	575-3-60	STD	29	35	31	145	29	35	31	145	31	35	33	147	31	35	33	147
		MED	29	35	31	145	29	35	31	145	31	35	33	147	31	35	33	147
		HIGH	34	40	36	157	34	40	36	157	36	40	38	159	36	40	38	159



**48HC\*\*04-14 WITH ERV, FACTORY INSTALLED HACR BREAKER, AND 2-SPEED INDOOR BLOWER OPTION MCA MOCP ELECTRICAL DATA**

48HC UNIT SIZE*	NOM. V-PH-HZ	IFM TYPE	NO C.O. OR UNPWR C.O.								W/ PWRD C.O.							
			W/ERV W/O ECONOMIZER				W/ERV W/ECONOMIZER				W/ERV W/O ECONOMIZER				W/ERV W/ECONOMIZER			
			MCA	HACR BRKR	DISC. SIZE		MCA	HACR BRKR	DISC. SIZE		MCA	HACR BRKR	DISC. SIZE		MCA	HACR BRKR	DISC. SIZE	
					FLA	LRA			FLA	LRA			FLA	LRA			FLA	LRA
D07	208/230-3-60	STD	39/39	50/50	40/39	173	39/39	50/50	40/39	173	44/44	60/60	45/45	178	44/44	60/60	45/45	178
		MED	42/42	50/50	43/42	203	42/42	50/50	43/42	203	47/47	60/60	48/47	208	47/47	60/60	48/47	208
		HIGH	47/47	60/60	49/47	238	47/47	60/60	49/47	238	52/52	60/60	54/53	243	52/52	60/60	54/53	243
	460-3-60	STD	19	25	19	85	19	25	19	85	21	25	22	87	21	25	22	87
		MED	20	25	20	101	20	25	20	101	22	30	23	103	22	30	23	103
		HIGH	23	30	23	118	23	30	23	118	25	30	26	120	25	30	26	120
	575-3-60	STD	16	20	16	72	16	20	16	72	18	20	18	74	18	20	18	74
		MED	18	20	18	85	18	20	18	85	20	25	20	87	20	25	20	87
		HIGH	20	25	20	99	20	25	20	99	21	25	22	101	21	25	22	101
D08	208/230-3-60	STD	52/52	60/60	55/55	207	52/52	60/60	55/55	207	57/57	60/60	61/60	212	57/57	60/60	61/60	212
		MED	53/53	60/60	57/56	211	53/53	60/60	57/56	211	58/58	70/70	62/62	216	58/58	70/70	62/62	216
		HIGH	57/57	60/60	61/60	261	57/57	60/60	61/60	261	62/62	70/70	66/65	266	62/62	70/70	66/65	266
	460-3-60	STD	24	30	25	103	24	30	25	103	26	30	28	105	26	30	28	105
		MED	25	30	26	106	25	30	26	106	27	30	29	108	27	30	29	108
		HIGH	26	30	28	131	26	30	28	131	28	30	30	133	28	30	30	133
	575-3-60	STD	19	20	21	85	19	20	21	85	21	25	22	87	21	25	22	87
		MED	20	25	21	89	20	25	21	89	22	25	23	91	22	25	23	91
		HIGH	21	25	22	98	21	25	22	98	23	25	24	100	23	25	24	100
D09	208/230-3-60	STD	52/52	60/60	55/55	207	52/52	60/60	55/55	207	57/57	60/60	61/61	212	57/57	60/60	61/61	212
		MED	53/53	60/60	57/57	211	53/53	60/60	57/57	211	58/58	70/70	62/62	216	58/58	70/70	62/62	216
		HIGH	57/57	70/70	61/60	261	57/57	70/70	61/60	261	62/62	70/70	67/66	266	62/62	70/70	67/66	266
	460-3-60	STD	24	30	26	103	24	30	26	103	27	30	28	105	27	30	28	105
		MED	25	30	26	106	25	30	26	106	27	30	29	108	27	30	29	108
		HIGH	26	30	28	131	26	30	28	131	29	30	31	133	29	30	31	133
	575-3-60	STD	21	25	22	85	21	25	22	85	22	25	24	87	22	25	24	87
		MED	21	25	23	89	21	25	23	89	23	25	25	91	23	25	25	91
		HIGH	22	25	24	98	22	25	24	98	24	25	26	100	24	25	26	100
D11	208/230-3-60	STD	63/63	70/70	67/67	266	63/63	70/70	67/67	266	67/67	80/80	73/72	271	67/67	80/80	73/72	271
		MED	66/66	80/80	71/70	316	66/66	80/80	71/70	316	71/71	80/80	77/76	321	71/71	80/80	77/76	321
		HIGH	69/69	80/80	74/73	327	69/69	80/80	74/73	327	74/74	80/80	80/79	332	74/74	80/80	80/79	332
	460-3-60	STD	29	30	30	128	29	30	30	128	31	35	33	130	31	35	33	130
		MED	30	35	32	153	30	35	32	153	32	35	35	155	32	35	35	155
		HIGH	32	35	34	158	32	35	34	158	34	40	36	160	34	40	36	160
	575-3-60	STD	24	30	26	103	24	30	26	103	26	30	28	105	26	30	28	105
		MED	25	30	27	112	25	30	27	112	27	30	29	114	27	30	29	114
		HIGH	27	30	29	126	27	30	29	126	29	35	31	128	29	35	31	128
D12	208/230-3-60	STD	61/61	70/70	66/65	291	61/61	70/70	66/65	291	66/66	80/80	71/71	296	66/66	80/80	71/71	296
		MED	65/65	80/80	70/69	341	65/65	80/80	70/69	341	70/70	80/80	75/74	346	70/70	80/80	75/74	346
		HIGH	68/68	80/80	73/72	352	68/68	80/80	73/72	352	73/73	80/80	79/78	357	73/73	80/80	79/78	357
	460-3-60	STD	30	35	31	140	30	35	31	140	32	35	34	142	32	35	34	142
		MED	31	35	33	165	31	35	33	165	33	40	36	167	33	40	36	167
		HIGH	33	35	35	170	33	35	35	170	35	40	37	172	35	40	37	172
	575-3-60	STD	25	30	26	113	25	30	26	113	26	30	28	115	26	30	28	115
		MED	26	30	27	122	26	30	27	122	27	30	29	124	27	30	29	124
		HIGH	28	30	29	136	28	30	29	136	29	35	31	138	29	35	31	138
D14	208/230-3-60	STD	74/74	80/80	79/78	353	74/74	80/80	79/78	353	79/79	90/90	84/83	358	79/79	90/90	84/83	358
		MED	76/76	90/90	81/80	377	76/76	90/90	81/80	377	81/81	90/90	87/86	382	81/81	90/90	87/86	382
		HIGH	86	100	92	392	86	100	92	392	91	100	98	397	91	100	98	397
	460-3-60	STD	32	35	34	172	32	35	34	172	34	40	37	174	34	40	37	174
		MED	33	40	35	184	33	40	35	184	35	40	38	186	35	40	38	186
		HIGH	39	45	41	191	39	45	41	191	41	50	44	193	41	50	44	193
	575-3-60	STD	29	35	31	145	29	35	31	145	31	35	33	147	31	35	33	147
		MED	29	35	31	145	29	35	31	145	31	35	33	147	31	35	33	147
		HIGH	34	40	36	157	34	40	36	157	36	40	38	159	36	40	38	159

# Electrical data (cont)

Legend and Notes for Electrical Data tables

**LEGEND**

- BRKR** — Circuit Breaker
- CO** — Convenience Outlet
- DISC** — Disconnect
- FLA** — Full Load Amps
- IFM** — Indoor Fan Motor
- LRA** — Locked Rotor Amps
- MCA** — Minimum Circuit Amps
- PE** — Power Exhaust
- PWRD CO** — Powered Convenient Outlet
- UNPWR CO** — Unpowered Convenient Outlet

**NOTES:**

1. In compliance with NEC requirements for multimotor and combination load equipment (refer to NEC Articles 430 and 440), the overcurrent protective device for the unit shall be fuse or HACR breaker. Canadian units may be fuse or circuit breaker.
2. Unbalanced 3-Phase Supply Voltage  
Never operate a motor where a phase imbalance in supply voltage is greater than 2%. Use the following formula to determine the percentage of voltage imbalance.

$$\% \text{ Voltage Imbalance} = 100 \times \frac{\text{max voltage deviation from average voltage}}{\text{average voltage}}$$

Example: Supply voltage is 230-3-60



- AB = 224 v
- BC = 231 v
- AC = 226 v

$$\text{Average Voltage} = \frac{(224 + 231 + 226)}{3} = \frac{681}{3} = 227$$

Determine maximum deviation from average voltage.

(AB) 227-224 = 3 v

(BC) 231-227 = 4 v

(AC) 227-226 = 1 v

Maximum deviation is 4 v.

Determine percent of voltage imbalance.

$$\% \text{ Voltage Imbalance} = 100 \times \frac{4}{227} = 1.78\%$$

This amount of phase imbalance is satisfactory as it is below the maximum allowable 2%.

**IMPORTANT:** If the supply voltage phase imbalance is more than 2%, contact your local electric utility company immediately.

## General

The sequence below describes the sequence of operation for an electro-mechanical unit with and without a factory-installed EconoMi\$er® IV and X (called “economizer” in this sequence). For information regarding a direct digital controller, see the start-up, operations, and troubleshooting manual for the applicable controller.

### Electro-Mechanical Units with No Economizer Cooling (Single Speed Indoor Fan Motor)

When the thermostat calls for cooling, terminals G and Y1 are energized. As a result, the indoor-fan contactor (IFC) and the compressor contactor (C1) are energized, causing the indoor-fan motor (IFM), compressor no. 1, and outdoor fan to start. If the unit has 2 stages of cooling, the thermostat will additionally energize Y2. On two compressor units, the Y2 signal will energize compressor contactor no. 2 (C2), causing compressor no. 2 to start. On 2-Stage 07 units, the Y1 signal energizes the IFC and C1 contactor, causing the indoor fan and outdoor fan to start and the compressor to operate at 66% capacity. The Y2 signal will energize the compressor loader plug, allowing compressor to operate at 100% capacity. Regardless of the number of stages, the outdoor fan motor runs continuously while unit is cooling.

**Cooling (2-speed indoor fan motor)** — Per ASHRAE 90.1-2016 and IECC-2015 standards during the first stage of cooling operation the VFD will adjust the fan motor to provide 66% of the total cfm established for the unit. When a call for the second stage of cooling is required, the VFD will allow the total cfm established for the unit (100%).

### Heating

NOTE: WeatherMaster® units have either 1 or 2 stages of gas heat.

When the thermostat calls for heating, power is sent to W on the Integrated Gas Controller (IGC) board. An LED (light-emitting diode) on the IGC board turns on and remains on during normal operation. A check is made to ensure that the roll-out switch and limit switch are closed. If the check was successful, the induced-draft motor is energized, and when its speed is satisfactory, as proven by the flue gas pressure switch, the ignition activation period begins. The burners will ignite within 5 seconds. If the burners do not light, there is a 22-second delay before another 5-second attempt. This sequence is repeated for 15 minutes or until the burners light. If, after the 15 minutes, the burners still have not lit, heating is locked out. To reset the control, break 24 V power to the thermostat.

When ignition occurs, the IGC board will continue to monitor the condition of the roll-out switch, the limit switches, the flue gas pressure switch, as well as the flame sensor. 45 seconds after ignition occurs, assuming the unit is controlled through a room thermostat set for fan auto, the indoor-fan motor will energize (and the outdoor-air dampers will open to their minimum position). If, for some reason, the over-temperature limit opens prior to the start of the indoor fan blower, the unit will shorten the 45-second delay to 5 seconds less than the time from initiation of heat to when the limit tripped. Gas will not be interrupted to the

burners and heating will continue. Once the fan-on delay has been modified, it will not change back to 45 seconds until power is reset to the control. On units with 2 stages of heat, when additional heat is required, W2 closes and initiates power to the second stage of the main gas valve. When the thermostat is satisfied, W1 and W2 open and the gas valve closes, interrupting the flow of gas to the main burners. If the call for W1 lasted less than 1 minute, the heating cycle will not terminate until 1 minute after W1 became active. If the unit is controlled through a room thermostat set for fan auto, the indoor-fan motor will continue to operate for an additional 45 seconds then stop. If the over-temperature limit opens after the indoor motor is stopped, but within 10 minutes of W1 becoming inactive, on the next cycle the time will be extended by 15 seconds. The maximum delay is 3 minutes. Once modified, the fan off delay will not change back to 45 seconds unless power is reset to the control. A LED indicator is provided on the IGC to monitor operation.

### Electro-mechanical Units with Factory-Installed EconoMi\$er Cooling (Single Speed Indoor Fan Motor, Non-EnergyX units)

**Cooling** — When free cooling is not available, the compressors will be controlled by the zone thermostat. When free cooling is available, the outdoor-air damper is modulated by the EconoMi\$er IV and X control to provide a 50°F (10°C) to 55°F (13°C) mixed-air temperature into the zone. As the mixed air temperature fluctuates above 55°F (13°C) or below 50°F (10°C) dampers will be modulated (open or close) to bring the mixed-air temperature back within control. If mechanical cooling is utilized with free cooling, the outdoor-air damper will maintain its current position at the time the compressor is started. If the increase in cooling capacity causes the mixed-air temperature to drop below 45°F (7°C), then the outdoor-air damper position will be decreased to the minimum position. If the mixed-air temperature continues to fall, the outdoor-air damper will close. Control returns to normal once the mixed-air temperature rises above 48°F (9°C). The power exhaust fans will be energized and de-energized, if installed, as the outdoor-air damper opens and closes.

If field-installed accessory CO<sub>2</sub> sensors are connected to the EconoMi\$er IV and X control, a demand controlled ventilation strategy will begin to operate. As the CO<sub>2</sub> level in the zone increases above the CO<sub>2</sub> set-point, the minimum position of the damper will be increased proportionally. As the CO<sub>2</sub> level decreases because of the increase in fresh air, the outdoor-air damper will be proportionally closed. For EconoMi\$er IV and X operation, there must be a thermostat call for the fan (G). If the unit is occupied and the fan is on, the damper will operate at minimum position. Otherwise, the damper will be closed.

When the EconoMi\$er IV and X control is in the occupied mode and a call for cooling exists (Y1 on the thermostat), the control will first check for indoor fan operation. If the fan is not on, then cooling will not be activated. If the fan is on, then the control will open the EconoMi\$er IV and X damper to the minimum position.

On the initial power to the EconoMi\$er IV and X control, it will take the damper up to 2 1/2 minutes before it begins to position itself. After the initial power-up, further changes in damper position can take up to 30 seconds to initiate. Damper movement from full closed to full open (or vice versa) will take between 1 1/2 and 2 1/2 minutes. If free cooling can be used as determined from the appropriate changeover command (switch, dry bulb, enthalpy curve, differential dry bulb, or differential enthalpy), then the control will modulate the dampers open to maintain the mixed-air temperature set-point at 50°F (10°C) to 55°F (13°C). If there is a further demand for cooling (cooling second stage — Y2 is energized), then the control will bring on compressor stage 1 to maintain the mixed-air temperature set-point. The EconoMi\$er IV and X damper will be open at maximum position.

**2-Speed Note:** When operating in ventilation mode only, the indoor fan motor will automatically adjust to 66% of the total cfm established.

**Heating** — The sequence of operation for the heating is the same as an electro-mechanical unit with no economizer. The only difference is how the economizer acts. The economizer will stay at the Economizer Minimum Position while the evaporator fan is operating. The outdoor-air damper is closed when the indoor fan is not operating. Refer to Service and Maintenance Manual for further details.

**Optional Humidi-MiZer® dehumidification system —**

Units with the factory equipped Humidi-MiZer system option are capable of providing multiple modes of improved dehumidification as a variation of the normal cooling cycle. The Humidi-MiZer system option includes additional valves in the liquid line and discharge line of each refrigerant circuit, a small reheat condenser coil downstream of the evaporator, and Motormaster® variable-speed control of some or all outdoor fans. Operation of the revised refrigerant circuit for each mode is described below.

The Humidi-MiZer system provides three sub-modes of operation: Cool, Reheat1, and Reheat2.

**Cool mode** — Provides a normal ratio of Sensible and Latent Cooling effect from the evaporator coil.

**Reheat1** — Provides increased Latent Cooling while slightly reducing the Sensible Cooling effect.

**Reheat2** — Provides normal Latent Cooling but with null or minimum Sensible Cooling effect delivered to the space.

The Reheat1 and Reheat2 modes are available when the unit is not in a Heating mode and when the Low Ambient Lockout switch is closed.

The figures on this page depict piping for single stage cooling units.

**RTU Open controller (factory option)** — For details on operating 48HC units equipped with the factory-installed RTU Open controller option refer to Factory Installed RTU Open Multi-Protocol Controller Controls, Start-Up, Operation and Troubleshooting manual.

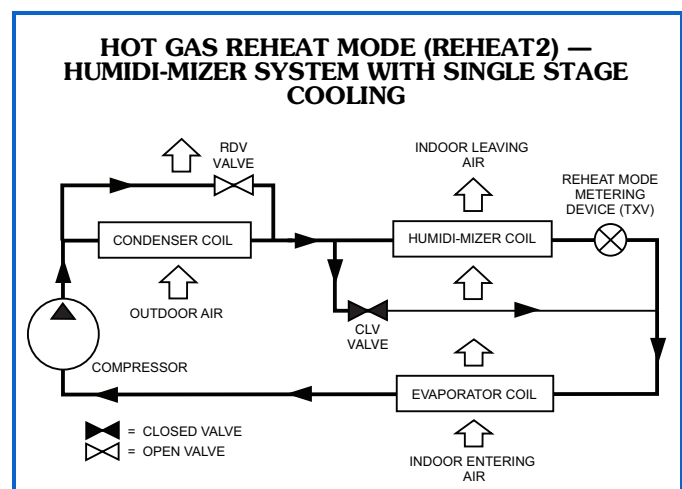
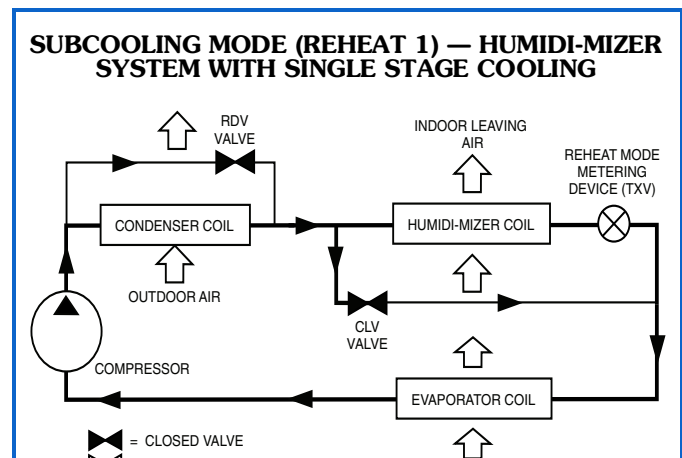
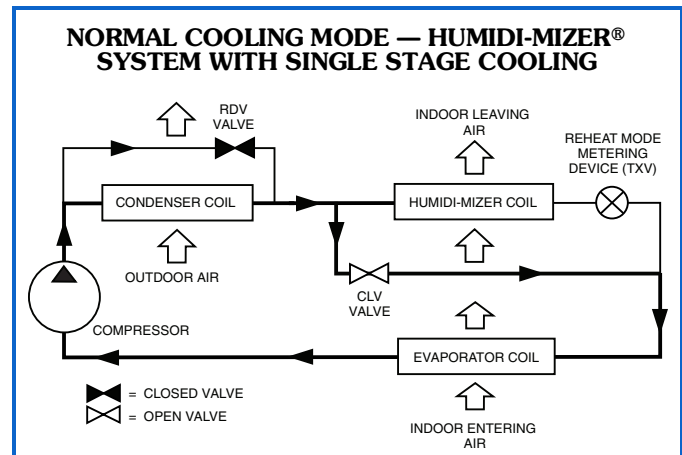

## Optional EnergyX® ERV (Energy Recovery Ventilator) System

The sequence below describes the sequence of operation for a WeatherMaster unit with *ComfortLink* controls and EnergyX system. For more information regarding controller operation, see the EnergyX Start-Up, Operations, and Troubleshooting supplement manual.

The EnergyX system will not activate unless the RTU fan is on. The EnergyX system default condition is to remain off in the unoccupied mode, however, this can be overridden via the control set points.

**Cooling operation** — When the *ComfortLink* controller recognizes that the conditioned zone requires cooling (via the space temperature sensor or space thermostat) the EnergyX module is activated. The EnergyX control module follows the sequence of operation logic as listed below.

**Step 1 — economizer operation** — First, the EnergyX module checks if the outside air is suitable for free cooling via the outside air enthalpy sensor. If the outside air is suitable for free cooling and the unit has an economizer, the EnergyX will operate in “ventilation mode” where the wheel will remain off but the ERV economizer will modulate in free-cooling. If the unit is in Unoccupied mode, then the unit will not operate in economizer mode and will proceed to Step 2.

**Step 2 — wheel operation** — If the outside air is not suitable for free cooling, then the EnergyX system will operate in either cooling or heating mode as called for by the rooftop unit *ComfortLink* controller.

NOTE: If the unit is in Unoccupied mode, the default configuration is that the EnergyX module will not operate. This can be overridden by an adjustable setpoint in the EnergyX controller.

If the outside air is not suitable for free cooling then the EnergyX wheel will activate and the supply fan will activate per the CFM setpoint.

If a CO<sub>2</sub> sensor is used (connected to the RTU Open or *ComfortLink* controller) the supply fan will modulate between the DCV (Demand Controlled Ventilation) minimum and DCV maximum setpoints. The exhaust fan will modulate to follow the supply fan operation per the Exhaust CFM-offset value. If the economizer opens more than 5%, the wheel utilizes a “stop-jog” operation to periodically rotate the wheel and minimize potential dirt build-up and excess wear on one section of the wheel.

NOTE: CO<sub>2</sub> sensor requires a factory-installed economizer.

**Heating operation** — When the *ComfortLink* controller sees that the space requires heating via the space temperature sensor or when the thermostat or calls for heating, the EnergyX module is activated. The ERV wheel will rotate and the supply fan will activate per the CFM setpoint.

If a CO<sub>2</sub> sensor is used (connected to the RTU Open or *ComfortLink* controller) the supply fan will modulate between the DCV minimum and DCV maximum setpoints. The exhaust fan will modulate to follow the supply fan operation per the Exhaust CFM-offset value, via the Economizer Control Board (ECB).

**Supply and exhaust air frost control operation** —

When the factory-installed frost protection option is used, the EnergyX module will sense pressure differential across the energy recovery cassette. The supply blower will be shut off if the pressure differential across the energy recovery cassette exceeds the adjustable setpoint value. The blower will remain off for 5 minutes. The exhaust blower and wheel will remain on, in order to remove any frost build-up on the wheel.

**EnergyX filter maintenance indicator operation** —

When the optional factory-installed filter maintenance indicator is used, a factory-installed differential pressure switch measures pressure drop across the outside air filter and activates a field-supplied dry contact indicator when the pressure differential exceeds the adjustable switch setpoint. EnergyX operation is not interrupted.

## BASE UNIT APPLICATION DATA

**Minimum operating ambient temperature (cooling)** — In mechanical cooling mode, your Carrier rooftop unit can safely operate down to an outdoor ambient temperature of 35°F (-2°C). It is possible to provide cooling at lower outdoor ambient temperatures by using less outside air, economizers, and/or accessory low ambient kits.

**Maximum operating ambient temp (cooling)** — The maximum operating ambient temperature for cooling mode is 125°F (52°C). While cooling operation above 125°F (52°C) may be possible, it could cause either a reduction in performance, reliability, or a protective action by the unit's internal safety devices.

**Multiple motor and drive packages** — Some applications need larger horsepower motors, some need more airflow, and some need both. Regardless of the case, your Carrier expert has a factory installed combination to meet your application. A wide selection of motors and pulleys (drives) are available, factory installed, to handle nearly any application.

**Stainless steel heat exchanger** — The stainless steel heat exchanger option provides the tubular heat exchanger be made out of a minimum 20 gage type 409 stainless steel for applications where the mixed air to the heat exchanger is expected to drop below 45°F (7°C). Stainless steel may be specified on applications where the presence of airborne contaminants require its use (applications such as paper mills) or in area with very high outdoor humidity that may result in severe in the heat exchanger during cooling operation.

**Minimum mixed air temperature (heating)** — Using the factory settings, the minimum temperatures for the mixed air (the combined temperature of the warm return air and the cold outdoor air) entering the dimpled, gas heat exchangers are shown in the table below.

**MINIMUM TEMPERATURE FOR MIXED AIR TEMPERATURE**

ALUMINIZED	STAINLESS STEEL
50°F (10°C) Continuous	40°F (4°C) Continuous
45°F (7°C) Intermittent	35°F (2°C) Intermittent

Operating at lower mixed-air temperatures may be possible, if a field-supplied, outdoor air thermostat initiates both heat stages when the temperature is less than the minimum temperatures listed above. Please contact your local Carrier representative for assistance.

**Minimum and maximum airflow (heating and cooling)** — To maintain safe and reliable operation of your rooftop, operate within the heating airflow limits during heating mode and cooling airflow limits during cooling mode. Operating above the max may cause blow-off, undesired airflow noise, or airflow related problems with the rooftop unit. Operating below the min may cause problems with coil freeze-up and unsafe heating operation. Heating and cooling limitations differ when evaluating operating CFM, the minimum value is the HIGHER of the cooling and heating minimum CFM values published on

page 7 and the maximum value is the LOWER of the cooling and heating minimum values published on page 7.

**Heating-to-cooling changeover** — Your unit will automatically change from heating to cooling mode when using a thermostat with an auto-changeover feature.

**Airflow** — All units are draw-through in cooling mode and blow-through in heating mode.

**Outdoor air application strategies** — Economizers reduce operating expenses and compressor run time by providing a free source of cooling and a means of ventilation to match application changing needs. In fact, they should be considered for most applications. Also, consider the various economizer control methods and their benefits, as well as sensors required to accomplish your application goals. Please contact your local Carrier representative for assistance.

**Motor limits, break horsepower (BHP)** — Due to internal design of Carrier units, the air path, and specially designed motors, the full horsepower (maximum continuous BHP) band, as listed in the Fan Performance tables, can be used with the utmost confidence. There is no need for extra safety factors, as Carrier motors are designed and rigorously tested to use the entire, listed BHP range without either nuisance tripping or premature motor failure.

**Propane heating** — Propane has different physical qualities than natural gas. As a result, propane requires different fuel to air mixture. To optimize the fuel/air mixture for propane, Carrier sells different burner orifices in an easy to install accessory kit. To select the correct burner orifices or determine the heat capacity for a propane application, use either the selection software, or the unit's service manual.

**High altitude heating** — High altitudes have less oxygen, which affects the fuel/air mixture in heat exchangers. In order to maintain a proper fuel/air mixture, heat exchangers operating in altitudes above 2000 ft (610 m) require different orifices. To select the correct burner orifices or determine the heat capacity for a high altitude application, use either the selection software, or the unit's service manual.

High altitudes have less oxygen, which means heat exchangers need less fuel. The new gas orifices in this field-installed kit make the necessary adjustment for high altitude applications. They restore the optimal fuel to air mixture and maintain healthy combustion on altitudes above 2000 ft (610 m).

NOTE: Typical natural gas heating value ranges from 975 to 1050 Btu/ft<sup>3</sup> at sea level nationally. The heating value goes down approximately 1.7% per every thousand feet elevation. Standard factory orifices can typically be used up to 2000 ft (610 m) elevation without any operational issues.

**Sizing a rooftop** — Bigger is not necessarily better. While an air conditioner needs to have enough capacity to meet the design loads, it does not need excess capacity. In fact, excess capacity typically results in very poor part load performance and humidity control.



Using higher design temperatures than ASHRAE recommends for your location, adding “safety factors” to the calculated load, are all signs of oversizing air conditioners. Oversizing the air conditioner leads to poor humidity control, reduced efficiency, higher utility bills, larger indoor temperature swings, excessive noise, and increased wear and tear on the air conditioner.

Rather than oversizing an air conditioner, engineers should “right-size” or even slightly “under-size” air conditioners. Correctly sizing an air conditioner controls humidity better; promotes efficiency; reduces utility bills; extends equipment life, and maintains even, comfortable temperatures. Please contact your local Carrier representative for assistance.

**Low ambient applications** — The optional Carrier economizer can adequately cool your space by bringing in fresh, cool outside air. In fact, when so equipped, accessory low-ambient kit may not be necessary. In low ambient conditions, unless the outdoor air is excessively humid or contaminated, economizer-based “free cooling” is the preferred less costly and energy conscious method. In low ambient applications where outside air might not be desired (such as contaminated or excessively humid outdoor environments), your Carrier rooftop can operate to ambient temperatures down to -20°F (-29°C) using the recommended accessory Motormaster® low ambient controller.

**Staged air volume (SAV™) system with VFD controller (2-stage cooling models only)** — Carrier’s staged air volume (SAV) system saves energy and installation time by utilizing a variable frequency drive (VFD) to automatically adjust the indoor fan motor speed in sequence with the units cooling operation. Per ASHRAE 90.1-2016 and IECC-2015, during the first stage of cooling operation the VFD will adjust the fan motor to provide two-thirds of the total cfm established for the unit. When a call for the second stage of cooling is required, the VFD will allow the total cfm for the unit established (100%). During the heating mode the VFD will allow total design cfm (100%) operation and during the ventilation mode the VFD will allow operation to two-thirds of total cfm.

Compared to single speed indoor fan motor systems, Carrier’s SAV system can save substantial energy, 25%+, versus single speed indoor fan motor systems.

**IMPORTANT:** Data based on .10 (\$/kWh) in an office application utilizing Carrier’s HAP 4.6 simulation software program.

The VFD used in Carrier’s SAV system has soft start capabilities to slowly ramp up the speeds, thus eliminating any high inrush air volume during initial start-up. It also has internal over current protection for the fan motor and a field installed display kit that allows adjustment and in depth diagnostics of the VFD.

This SAV system is available on models with 2-stage cooling operation.

The SAV system is very flexible for initial fan performance set up and adjustment. The standard factory shipped VFD is pre-programmed to automatically stage the fan speed between the first and second stage of cooling. The unit fan performance static pressure and cfm can be easily adjusted using the traditional means of pulley adjustments. The other means to adjust the unit static and cfm performance is to utilize the field-installed display kit and adjust the frequency and voltage in the VFD to required performance requirements. In either case, once set up, the VFD will automatically adjust the speed between the cooling stage operations.

**48HC STAGED AIR VOLUME (SAV) — VARIABLE FREQUENCY DRIVE (VFD) HP RATING**

48HC UNIT	VOLTAGE	STATIC OPTION	VFD HP RATING
07	208/230, 460, 575	STD	3.0
	208/230, 460	MED	3.0
	575	MED	5.0
08	208/230, 460, 575	HIGH	7.5
	208/230, 460, 575	STD	3.0
	208/230, 460, 575	MED	3.0
09	208/230, 460, 575	HIGH	5.0
	208/230, 460, 575	STD	3.0
	208/230, 460, 575	MED	5.0
11	208/230, 460, 575	HIGH	3.0
	208/230, 460, 575	STD	3.0
	208/230, 460, 575	MED	5.0
12	208/230, 460, 575	HIGH	7.5
	208/230, 460, 575	STD	3.0
	208/230, 460, 575	MED	5.0
14	208/230, 460, 575	HIGH	7.5
	208/230, 460, 575	STD	3.0
	575	STD	5.0
	208/230, 460, 575	MED	5.0

## ENERGYX APPLICATION DATA

### ASHRAE 62.1 air classification requirements —

The EnergyX<sup>®</sup> system allows for easy compliance with the current ASHRAE Standard 62.1 air classification requirements. Pollutant transfer via Desiccant is a 'non issue' since by virtue of the ASHRAE "classes of air" the main determinant is EATR or cross transfer of air by leakage from exhaust to supply. Since the EATR is an AHRI Certified measurement of an AHRI certified wheel device, the user can be assured of meeting the air dilution requirements of ASHRAE 62.1 and therefore the air classification requirements.

Industrial applications are by definition those that are Class 4 air (or worse). Most wheel manufacturers do not encourage application of wheels to these types of applications. When required, many wheel manufacturers make specialty wheels with specific mechanical purge construction for industrial applications, that can be used to field-replace the factory provided wheels. Contact the applicable wheel manufacture for specific application details.

Choosing the proper airflow is essential. Unit selection guidance for the EnergyX system is in definite contrast to typical unit sizing and selections. Typical unit sizing methods are to select the energy recovery device per the desired amount of outdoor air and then calculate the total capacity of the resulting energy recovery unit. This capacity is then subtracted from the desired total capacity for the conditioned zone. The remaining value is the necessary capacity of the rooftop unit. By conventional cooling and heating capacity guidance, the effort is to reduce the amount of outside (ventilation air) as much as possible since this additional ventilation air results in increased load on the rooftop unit compressor and heating sections.

NOTE: All units can be used in applications that require more or less airflow than the published CFM operating range as long as the airflow range is within the capabilities of the EnergyX fan system. This option can be used for high-static applications.

Although performance is optimized at equal exhaust and supply airflow rates, the selection program and the EnergyX unit can be used with unequal airflow amounts. The unit must be sized for the largest airflow amount. The smaller airflow used cannot be less than 50% of the larger airflow in the published range.

**Energy recovery wheels** — Carrier's EnergyX energy recovery wheels consist of a welded stainless steel hub, spoke and rim assembly, which is independent of the heat transfer matrix. The heat transfer matrix is contained in patented energy transfer segments, removable from the wheel without requiring tools. The energy wheel uses a unique parallel plate geometry and polymer film substrate to provide an optimized heat exchanger design. The polymer film construction is not subject to corrosion in coastal locations or swimming pool areas.

**Silica gel technology** — The EnergyX energy recovery wheels use the desiccant material known as silica gel, which is a highly porous solid adsorbent material that structurally resembles a rigid sponge. It has a very large internal surface composed of myriad microscopic cavities and a vast system of

capillary channels that provide pathways connecting the internal microscopic cavities to the outside surface of the sponge. Silica gel enthalpy wheels transfer water by rotating between two air streams of different vapor pressures. The vapor pressure differential drives molecules into/from these cavities to transfer moisture from the more humid airstream to the drier airstream.

MICROSCOPIC IMAGE OF SILICA GEL

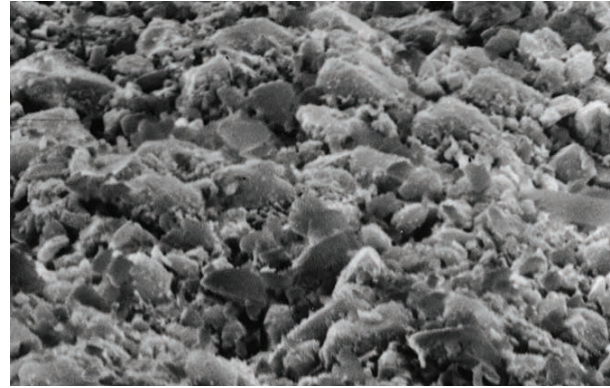

**Adsorption: silica gel vs. molecular sieve** — The graph on page 123 shows the effect of Relative Humidity on Desiccant Capacity characteristic curve for adsorption of water on silica gel. It shows the percent weight adsorbed versus relative humidity of the airstream in contact with the silica gel. The amount of water adsorbed rises linearly with increasing relative humidity (RH) until RH reaches near 60%. It then plateaus at above 40% adsorbed as relative humidity approaches 100%. For contrast, the curve for molecular sieves rises rapidly to plateau at about 20% adsorbed at 20% RH.

The Effect of Relative Humidity on Desiccant Capacity graph explains the following application considerations:

- Molecular sieves are preferred for regenerated applications such as desiccant cooling and dehumidification systems that must reduce the processed air streams to very low relative humidities.
- Silica gel has superior characteristics for recovering space conditioning energy from exhaust air and handling high relative humidity outside conditions.

The transfer of water by adsorption/desorption is not dependent on temperature. Therefore, the silica gel enthalpy wheel works to reduce latent load at difficult part-load conditions.

**Fungal growth and moisture transfer** — Carrier EnergyX units have silica gel-based desiccant wheels. The water molecules are individually transferred by desorption/adsorption to and from the silica gel surfaces. Water is present on the wheel in a molecular layer only, and condensation does not occur. Therefore, Carrier's energy recovery wheels experience dry moisture transfer; there is no bulk liquid water present that could support fungal growth. Water transfer to and from the wheel's desiccant surfaces occurs in the vapor phase; there are no wet surfaces and liquid water does not enter the airstream. Silica gel is also highly selective for water, based on the strong preference of the gel surface for the dipolar water molecule over other compounds.

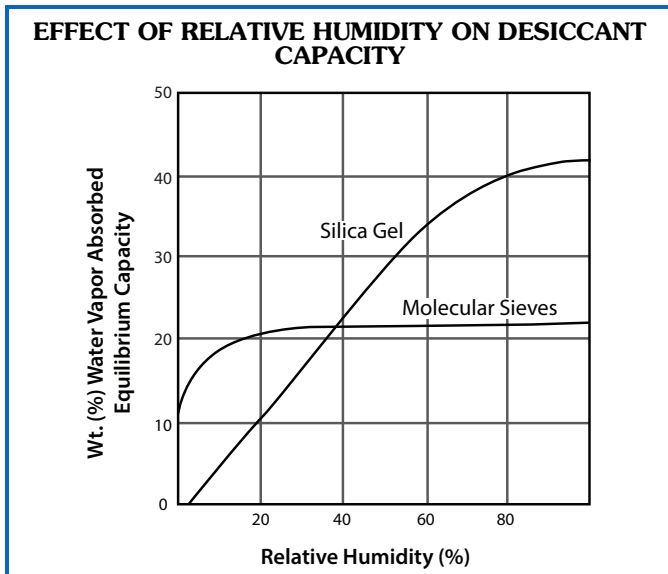

**Frost control requirements** — Energy recovery systems require frost protection or a means of defrosting in climates that experience severe winter conditions. Frost formation results in a reduction and eventual blockage of air-flow through the energy wheel.

Frost formation causes reduced airflow through the heat exchanger. Without frost control, energy recovery and airflow may be significantly reduced. The frost threshold temperature is the point at which frost begins to accumulate on heat exchanger surfaces. It is a function of both outside temperature and indoor relative humidity.

The Frost Threshold Comparison figure compares the frost threshold of a plate-type sensible heat exchanger with that of an enthalpy wheel. Note that frost forms at temperatures between 22°F and 30°F in a plate-type heat exchanger, frost threshold temperatures for enthalpy wheels are generally 20°F to 30°F degrees lower, approximately 0°F to 20°F. This is because the enthalpy wheel removes water from the exhaust air-stream, effectively lowering the exhaust's dew point. The water removed is subsequently picked up through desorption by the entering outdoor air. Depending on the indoor relative humidity in areas where winter outside temperatures are between -5°F and 22°F, enthalpy wheel based recovery systems have a significant advantage over sensible plate type units because there is no additional cost for frost control. Even in cold areas, in most cases, enthalpy wheel based systems for schools and office buildings can be designed without frost control because most of the frosting hours are at night when the building is unoccupied. Consult bin data, such as that provided by ASHRAE, to qualify daytime applications in cold climates for frost-free operation.

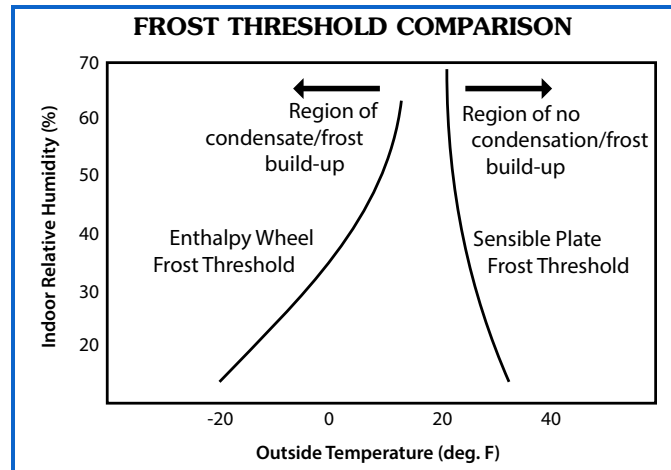

The Frost Thresholds Temperatures table lists typical frost threshold temperatures for Carrier's EnergyX® energy recovery wheels over a wide range of indoor-air temperatures and relative humidity. Frost control is not required until outdoor air temperatures are below the threshold.

#### FROST THRESHOLD TEMPERATURE (°F)

INDOOR AIR RELATIVE HUMIDITY (%)	INDOOR AIR DRY BULB TEMPERATURE (F)			
	70°F	72°F	75°F	80°F
20	-14	-13	-11	-8
30	-3	-2	-1	3
40	5	7	9	11
50	12	13	15	18
60	18	19	21	26

In regions where winter temperatures are extreme, Carrier's energy recovery wheels can be used effectively with the frost protection factory-installed option (FIOP).

NOTE: Refer to ASHRAE for bin data in cold climates where the threat of wheel frosting is frequent. Consult this information to ensure appropriate preheat techniques are used during occupied times.

Frost prevention for frost control is required in extremely cold climates to preserve performance and assure the continuous supply of outdoor air. Enthalpy wheel frost control strategies take advantage of inherently low frosting thresholds. This results in minimized energy use and maximized design load reductions. In regions that experience extreme winter conditions, the frost protection FIOP allows the exhaust fan to operate below the frost threshold temperature; however, a temperature sensor would disable the supply fan when the outdoor-air temperatures reach the frost control set-point. The outdoor-air temperature sensor is located in the outdoor air intake of the ERV section. To avoid depressurization of the space, fresh air dampers may be required as part of the building's ventilation system.

**Economizers** — As promulgated by ASHRAE, economizers reduce operating expenses and compressor run time by providing a source of free cooling and a means of ventilation to match changing application needs. When properly designed (per ASHRAE standards), the economizer will control the amount of outdoor air allowed into the building and is integrated with the operation of the compressors. Carrier economizers are properly designed and allow free cooling to occur when the outdoor air is suitable depending upon the control strategy chosen.

It has also been proven (by multiple independent sources) that using a demand controlled ventilation (CO<sub>2</sub>) strategy will result in considerable energy savings over a constant outdoor air volume strategy. This is because air to be brought in at a fixed rate has no variability as the outside air conditions change. Modulating EnergyX systems with DCV control allows the outside ventilation air to be reduced to the minimum building ventilation requirements as required by the actual occupancy load, which in turn reduces the load on the unit compressors or heating system.

It is recommended that an economizer option always be used with the EnergyX system. This allows for true free cooling operation when the outside air conditions allow for it.

**Wheel cleaning** — The EnergyX system includes a 5-year wheel warranty as a standard product feature. Wheels are self cleaning from dry dust and dirt due to laminar airflow through the wheel. If volatile organic compounds (VOCs) are present, wheels need to be 'deep' cleaned just like evaporator coils must be in order to maintain latent recovery performance. Since it is easier and less risky to clean a wheel

outside of the HVAC unit than within, EnergyX unit construction allows for easy wheel segment removal.

It is recommended that a different wheel segment be cleaned each time the unit air filters are changed in order to ensure periodic entire wheel cleaning. Wheel cleaning can be done simply and easily by hand. Proper wheel cleaning does not remove wheel desiccant. See the EnergyX Controls and Troubleshooting Supplement Instructions for additional wheel cleaning and service information.

**Exhaust fan performance** — Many applications that utilize energy recovery incorporate ducted return/exhaust air paths. In these applications, it is important to consider the duct pressure of the return/exhaust just as a designer would consider the effects of the supply duct static pressure on the airflow of the rooftop unit itself.

EnergyX modulating volume 3 to 12.5 ton units — The exhaust fan in the Modulating Volume EnergyX unit will assist the rooftop unit fan in pulling air through the exhaust/return duct. These exhaust fans are backwards curved impeller designs which are capable of significant more static pressure operation than typical forward curved fan designs.

NOTE: If application designs require two separate ducts (one for exhaust air, one for return air) contact your Carrier Sales Engineer for additional guidance prior to specification or ordering.

“Masterformat” as published by the Construction Specification Institute. Please feel free to copy this specification directly into your building spec.



## WeatherMaster® Gas Heat/Electric Cooling Packaged Rooftop

### HVAC guide specifications

Size range: **3 to 12.5 Nominal Tons**

Carrier Model Number: **48HC\*04-14**

#### Part 1 — (23 06 80) Schedules for decentralized HVAC equipment

1.01 (23 06 80.13) Decentralized Unitary HVAC Equipment Schedule

- A. (23 06 80.13.A.) Rooftop unit (RTU) schedule
1. Schedule is per the project specification requirements.

#### Part 2 — (23 07 16) HVAC equipment insulation

2.01 (23 07 16.13) Decentralized, Rooftop Units:

- A. (23 07 16.13.A.) Evaporator fan compartment:
1. Interior cabinet surfaces shall be insulated with a minimum 1/2-in. thick, minimum 1 1/2-lb density, flexible fiberglass insulation bonded with a phenolic binder, neoprene coated on the air side.
  2. Insulation and adhesive shall meet NFPA 90A requirements for flame spread and smoke generation.
  3. Unit internal insulation linings shall be resistant to mold growth in accordance with “mold growth and humidity” test in ASTM C1338, G21, and UL 181 or comparable test method. Air stream surfaces shall be evaluated in accordance with the “Erosion Test” in UL 181, as part of ASTM C1071.
- B. (23 07 16.13.B.) Gas Heat Compartment:
1. Aluminum foil-faced fiberglass insulation shall be used.
  2. Insulation and adhesive shall meet NFPA 90A requirements for flame spread and smoke generation.

#### Part 3 — (23 09 13) Instrumentation and control devices for HVAC

3.01 (23 09 13.23) Sensors and Transmitters

- A. (23 09 13.23.A.) Thermostats
1. Thermostat must
    - a. energize both “W” and “G” when calling for heat.
    - b. have capability to energize 2 different stages of cooling, and 2 different stages of heating.
    - c. include capability for occupancy scheduling.

#### Part 4 — (23 09 23) Direct-digital control system for HVAC

4.01 (23 09 23.13) Decentralized, Rooftop Units:

- A. (23 09 23.13.A.) PremierLink™ Controller
1. Shall be ASHRAE 62 compliant.
  2. Shall accept 18-32 VAC input power.
  3. Shall have an operating temperature range from -40°F (-40°C) to 158°F (70°C), 10% to 95% RH (non-condensing).
  4. Shall include an integrated economizer controller to support an economizer with 4 to 20 mA actuator input and no microprocessor controller.
  5. Controller shall accept the following inputs: space temperature, setpoint adjustment, outdoor air temperature, indoor air quality, outdoor air quality, indoor relative humidity, compressor lock-out, fire shutdown, enthalpy, fan status, remote time clock/door switch.
  6. Shall accept a CO<sub>2</sub> sensor in the conditioned space, and be Demand Controlled Ventilation (DCV) ready.
  7. Shall provide the following outputs: economizer, fan, cooling stage 1, cooling stage 2, heat stage 1, heat stage 2, heat stage 3/exhaust/ reversing valve/ dehumidify/ occupied.
  8. Unit shall provide surge protection for the controller through a circuit breaker.
  9. Shall be Internet capable, and communicate at a Baud rate of 38.4K or faster.
  10. Shall have an LED display independently showing the status of activity on the communication bus, and processor operation.
  11. Shall include an EIA-485 protocol communication port, an access port for connection of either a computer or a Carrier technician tool, an EIA-485 port for network communication to intelligent space sensors and displays, and a port to connect an optional LonWorks<sup>1</sup> plug-in communications card.
  12. Shall have built-in Carrier Comfort Network® (CCN) protocol, and be compatible with other CCN devices, including ComfortLink and ComfortVIEW™ controllers.
  13. Shall have built-in support for Carrier technician tool.
  14. Software upgrades will be accomplished by local download. Software upgrades through chip replacements are not allowed.
  15. Shall be shock resistant in all planes to 5G peak, 11ms during operation, and 100G peak, 11ms during storage.
  16. Shall be vibration resistant in all planes to 1.5G at 20-300 Hz.

1. LonWorks is a registered trademark of Echelon Corporation.

17. Shall support a bus length of 4000 ft (1219 m) max, 60 devices per 1000 ft (305 m) section, and 1 RS-485 repeater per 1000 ft (305 m) sections.
- B. (23 09 23.13.B.) RTU Open Protocol, Direct Digital Controller:
1. Shall be ASHRAE 62 compliant.
  2. Shall accept 18-30VAC, 50-60Hz, and consume 15VA or less power.
  3. Shall have an operating temperature range from -40°F (-40°C) to 130°F (54°C), 10% to 90% RH (non-condensing).
  4. Shall include built-in protocol for BACnet<sup>1</sup> (MS/TP and PTP modes), Modbus<sup>2</sup> (RTU and ASCII), Johnson N2 and LonWorks. LonWorks Echelon processor required for all Lon applications shall be contained in separate communication board.
  5. Shall allow access of up to 62 network variables (SNVT). Shall be compatible with all open controllers.
  6. Baud rate Controller shall be selectable using a dip switch.
  7. Shall have an LED display independently showing the status of serial communication, running, errors, power, all digital outputs, and all analog inputs.
  8. Shall accept the following inputs: space temperature, setpoint adjustment, outdoor air temperature, indoor air quality, outdoor air quality, compressor lock-out, fire shutdown, enthalpy switch, and fan status / filter status / humidity / remote occupancy.
  9. Shall provide the following outputs: economizer, variable frequency drive, fan, cooling stage 1, cooling stage 2, heat stage 1, heat stage 2, exhaust reversing valve/high fan speed.
  10. Shall have built-in surge protection circuitry through solid-state polyswitches. Polyswitches shall be used on incoming power and network connections. Polyswitches will return to normal when the “trip” condition clears.
  11. Shall have a battery backup capable of a minimum of 10,000 hours of data and time clock retention during power outages.
  12. Shall have built-in support for Carrier technician tool.
  13. Shall include an RS-485 protocol communication port, an access port for connection of either a computer or a Carrier technician tool, an RS-485 port for network communication to intelligent space sensors and displays, and a port to connect an optional LonWorks communications card.
14. Software upgrades will be accomplished by either local or remote download. No software upgrades through chip replacements are allowed.
- C. (23 09 23.13.C.) ComfortLink Unit Controls shall contain:
1. Four button detailed English scrolling marquee display.
  2. CCN (Carrier Comfort Network) capable.
  3. Unit control with standard suction pressure transducers and condensing temperature thermistors.
  4. Shall provide a 5°F temperature difference between cooling and heating set points to meet ASHRAE 90.1-2016 Energy Standard.
  5. Shall provide and display a current alarm list and an alarm history list.
  6. Service run test capability.
  7. Shall accept input from a CO<sub>2</sub> sensor (both indoor and outdoor).
  8. Configurable alarm light shall be provided which activates when certain types of alarms occur.
  9. Compressor minimum run time (3 minutes) and minimum off time (5 minutes) are provided.
  10. Service diagnostic mode.
  11. Economizer control (optional).
  12. Control multiple capacity stages.
  13. Unit shall be complete with self-contained low voltage control circuit.
  14. Unit shall have 0°F low ambient cooling operation.

## Part 5 — (23 09 33) Electric and electronic control system for HVAC

### 5.01 (23 09 33.13) Decentralized, Rooftop Units

#### A. (23 09 33.13.A) General:

1. Shall be complete with self-contained low-voltage control circuit protected by a resettable circuit breaker on the 24-v transformer side. Transformer shall have 75VA capability.
2. Shall utilize color-coded wiring.
3. Shall include a central control terminal board to conveniently and safely provide connection points for vital control functions such as: smoke detectors, phase monitor, economizer, thermostat, DDC control options, loss of charge, freeze switch, high pressure switches.
4. The heat exchanger shall be controlled by an integrated gas controller (IGC) microprocessor. See heat exchanger section of this specification.
5. Unit shall include a minimum of one 8-pin screw terminal connection board for connection of control wiring.

1. BACnet is a registered trademark of ASHRAE (American Society of Heating, Refrigerating and Air-Conditioning Engineers).

2. Modbus is a registered trademark of Schneider Electric.

B. (23 09 33.23.B) Safeties:

1. Compressor over-temperature, over-current.
2. Low-pressure switch.
  - a. Units with 2 compressors shall have different sized connectors for the circuit 1 and circuit 2 loss of charge switches. They shall physically prevent the cross-wiring of the safety switches between circuits 1 and 2.
  - b. Loss of charge switch shall use different color wire than the high pressure switch. The purpose is to assist the installer and service technician to correctly wire and/or troubleshoot the rooftop unit.
3. High-pressure switch.
  - a. Units with 2 compressors shall have different sized connectors for the circuit 1 and circuit 2 high pressure switches. They shall physically prevent the cross-wiring of the safety switches between circuits 1 and 2.
  - b. High-pressure switch shall use different color wire than the low-pressure switch. The purpose is to assist the installer and service technician to correctly wire and/or troubleshoot the rooftop unit.
4. Automatic reset, motor thermal overload protector.
5. Heating section shall be provided with the following minimum protections.
  - a. High-temperature limit switches.
  - b. Induced draft motor speed sensor.
  - c. Flame rollout switch.
  - d. Flame proving controls.

**Part 6 — (23 09 93) Sequence of operations for HVAC controls**

6.01 (23 09 93.13) Decentralized, Rooftop Units:

- A. (23 09 93.13.A) INSERT SEQUENCE OF OPERATION

**Part 7 — (23 40 13) Panel air filters**

7.01 (23 40 13 13) Decentralized Rooftop Units:

- A. (23 40 13 13.A) Standard Filter Section
1. Shall consist of factory-installed, low velocity, throwaway 2-in. thick fiberglass filters of commercially available sizes.
  2. Unit shall use only one filter size. Multiple sizes are not acceptable.
  3. Filters shall be accessible through an access panel with “no-tool” removal as described in the unit cabinet section of this specification (23 81 19.13.G).

**Part 8 — (23 81 19) Self-contained air conditioners**

8.01 (23 81 19.13) Small-Capacity Self-Contained Air Conditioners (48HC\*\*04-14)

A. (23 81 19.13.A) General

1. Outdoor, rooftop mounted, electrically controlled, heating and cooling unit utilizing hermetic scroll compressor(s) for cooling duty and gas combustion for heating duty.
2. Factory assembled, single piece heating and cooling rooftop unit. Contained within the unit enclosure shall be all factory wiring, piping, controls, and special features required prior to field start-up.
3. Unit shall use Puron® refrigerant.
4. Unit shall be installed in accordance with the manufacturer’s instructions.
5. Unit must be selected and installed in compliance with local, state, and federal codes.

B. (23 81 19.13.B.) Quality Assurance

1. Unit meets ASHRAE 90.1-2016 and IECC-2015 minimum efficiency requirements.
2. 3-phase units are ENERGY STAR<sup>1</sup> qualified.
3. Unit shall be rated in accordance with AHRI Standards 210/240 and 340/360.
4. Unit shall be designed to conform to ASHRAE 15.
5. Unit shall be UL-tested and certified in accordance with ANSI Z21.47 Standards and UL or ETL-listed and certified under Canadian standards as a total package for safety requirements.
6. Insulation and adhesive shall meet NFPA 90A requirements for flame spread and smoke generation.
7. Unit internal insulation linings shall be resistant to mold growth in accordance with “mold growth and humidity” test in ASTM C1338, G21, and UL 181 or comparable test method. Air stream surfaces shall be evaluated in accordance with the “Erosion Test” in UL 181, as part of ASTM C1071.
8. Unit casing shall be capable of withstanding 500-hour salt spray exposure per ASTM B117 (scribed specimen).
9. Roof curb shall be designed to conform to NRCA Standards.
10. Unit shall be subjected to a completely automated run test on the assembly line. The data for each unit will be stored at the factory, and must be available upon request.
11. Unit shall be designed in accordance with UL Standard 1995, including tested to withstand rain.

---

1. ENERGY STAR is a registered trademark of the U.S. Environmental Protection Agency.

12. Unit shall be constructed to prevent intrusion of snow and tested to prevent snow intrusion into the control box up to 40 mph.
  13. Unit shake tested to assurance level 1, ASTM D4169 to ensure shipping reliability.
  14. High Efficiency Motors listed shall meet section 313 of the Energy Independence and Security Act of 2007 (EISA 2007).
- C. (23 81 19.13.C) Delivery, Storage, and Handling
1. Unit shall be stored and handled per manufacturer's recommendations.
  2. Lifted by crane requires either shipping top panel or spreader bars.
  3. Unit shall only be stored or positioned in the upright position.
- D. (23 81 19.13.D) Project Conditions
1. As specified in the contract.
- E. (23 81 19.13.E) Operating Characteristics
1. Unit shall be capable of starting and running at 125°F (52°C) ambient outdoor temperature, meeting maximum load criteria of AHRI Standard 340/360 at ± 10% voltage.
  2. Compressor with standard controls shall be capable of operation from 35°F (2°C), ambient outdoor temperatures. Accessory kits are necessary if mechanically cooling at ambient temperatures below 35°F (2°C).
  3. Unit shall discharge supply air vertically as shown on contract drawings.
  4. Unit shall be factory configured and ordered for vertical supply and return configurations.
  5. Unit shall be factory furnished in vertical configurations.
  6. Unit shall be capable of mixed operation: vertical supply with horizontal return or horizontal supply with vertical return.
- F. (23 81 19.13.F) Electrical Requirements
1. Main power supply voltage, phase, and frequency must match those required by the manufacturer.
  2. Control Panel SCCR (short circuit current rating): 5kA RMS at Rated Symmetrical Voltage.
- G. (23 81 19.13.G) Unit Cabinet
1. Unit cabinet shall be constructed of galvanized steel, and shall be bonderized and coated with a pre-painted baked enamel finish on all externally exposed surfaces.
  2. Unit cabinet exterior paint shall be: film thickness, (dry) 0.003 inches minimum, gloss (per ASTM D523, 60°): 60, Hardness: H-2H Pencil hardness.
  3. Evaporator fan compartment interior cabinet insulation shall conform to AHRI Standards 340/360 minimum exterior sweat criteria. Interior surfaces shall be insulated with a minimum 1/2-in. thick, 1 lb density, flexible fiberglass insulation, neoprene coated on the air side. Aluminum foil-faced fiberglass insulation shall be used in the heat compartment.
4. Unit internal insulation linings shall be resistant to mold growth in accordance with "mold growth and humidity" test in ASTM C1338, G21, and UL 181 or comparable test method. Air stream surfaces shall be evaluated in accordance with the "Erosion Test" in UL 181, as part of ASTM C1071.
  5. Base of unit shall have a minimum of four locations for factory thru-the-base gas and electrical connections (factory-installed or field-installed) standard. Connections shall be internal to the cabinet to protect from environmental issues.
  6. Base Rail:
    - a. Unit shall have base rails on a minimum of 2 sides.
    - b. Holes shall be provided in the base rails for rigging shackles to facilitate maneuvering and overhead rigging.
    - c. Holes shall be provided in the base rail for moving the rooftop by fork truck.
    - d. Base rail shall be a minimum of 16 gauge thickness.
  7. Condensate Pan and Connections:
    - a. Shall be a sloped condensate drain pan made of a non-corrosive material.
    - b. Shall comply with ASHRAE Standard 62.
    - c. Shall use a 3/4-in. 14 NPT drain connection at the end of the drain pan. Connection shall be made per manufacturer's recommendations.
  8. Top Panel:
    - a. Shall be a multi-piece top panel linked with water tight flanges and interlocking systems.
  9. Gas Connections:
    - a. All gas piping connecting to unit gas valve shall enter the unit cabinet at a single location on side of unit (horizontal plane).
    - b. Thru-the-base capability
      - 1) Standard unit shall have a thru-the-base gas-line location using a raised, embossed portion of the unit basepan.
      - 2) Optional, factory-approved, water-tight connection method must be used for thru-the-base gas connections.
      - 3) No basepan penetration, other than those authorized by the manufacturer, is permitted.
  10. Electrical Connections:
    - a. All unit power wiring shall enter unit cabinet at a single, factory-prepared, knockout location.



- b. Thru-the-base capability
  - 1) Standard unit shall have a thru-the-base electrical location(s) using a raised, embossed portion of the unit basepan.
  - 2) Optional, factory-approved, water-tight connection method must be used for thru-the-base electrical connections.
  - 3) No basepan penetration, other than those authorized by the manufacturer, is permitted.

11. Component Access Panels (standard):

- a. Cabinet panels shall be easily removable for servicing.
- b. Unit shall have one factory installed, tool-less, removable, filter access panel.
- c. Panels covering control box and filters shall have molded composite handles while the blower access door shall have an integrated flange for easy removal.
- d. Handles shall be UV modified, composite, permanently attached, and recessed into the panel.
- e. Screws on the vertical portion of all removable access panel shall engage into heat resistant, molded composite collars.
- f. Collars shall be removable and easily replaceable using manufacturer recommended parts.

H. (23 81 19.13.H.) Gas Heat

1. General:

- a. Heat exchanger shall be an induced draft design. Positive pressure heat exchanger designs shall not be allowed.
- b. Shall incorporate a direct-spark ignition system and redundant main gas valve.
- c. Gas supply pressure at the inlet to the rooftop unit gas valve must match that required by the manufacturer.

2. The heat exchanger shall be controlled by an integrated gas controller (IGC) microprocessor.

- a. IGC board shall notify users of fault using an LED (light-emitting diode).
- b. The LED shall be visible without removing the control box access panel.
- c. IGC board shall contain algorithms that modify evaporator-fan operation to prevent future cycling on high temperature limit switch.
- d. Unit shall be equipped with anti-cycle protection with one short cycle on unit flame roll-out switch or 4 continuous short cycles on the high temperature limit switch. Fault indication shall be made using an LED.

3. Standard Heat Exchanger Construction:

- a. Heat exchanger shall be of the tubular-section type constructed of a minimum of 20-gauge

steel coated with a nominal 1.2 mil aluminum-silicone alloy for corrosion resistance.

- b. Burners shall be of the in-shot type constructed of aluminum-coated steel.
- c. Burners shall incorporate orifices for rated heat output up to 2000 ft (610m) elevation. Additional accessory kits may be required for applications above 2000 ft (610m) elevation, depending on local gas supply conditions.
- d. Each heat exchanger tube shall contain multiple dimples for increased heating effectiveness.

4. Optional Stainless Steel Heat Exchanger Construction:

- a. Use energy saving, direct-spark ignition system.
- b. Use a redundant main gas valve.
- c. Burners shall be of the in-shot type constructed of aluminum-coated steel.
- d. All gas piping shall enter the unit cabinet at a single location on side of unit (horizontal plane).
- e. The optional stainless steel heat exchanger shall be of the tubular-section type, constructed of a minimum of 20-gauge type 409 stainless steel.
- f. Type 409 stainless steel shall be used in heat exchanger tubes and vestibule plate.
- g. Complete stainless steel heat exchanger allows for greater application flexibility.

5. Optional Low NO<sub>x</sub> Heat Exchanger Construction:

- a. Low NO<sub>x</sub> reduction shall be provided to reduce nitrous oxide emissions to meet California's Air Quality Management District (SCAQMD) low-NO<sub>x</sub> emissions requirement of 40 nanograms per joule or less.
- b. Primary tubes and vestibule plates on low NO<sub>x</sub> units shall be 409 stainless steel. Other components shall be aluminized steel.

6. Induced Draft Combustion Motor and Blower:

- a. Shall be a direct-drive, single inlet, forward-curved centrifugal type.
- b. Shall be made from steel with a corrosion-resistant finish.
- c. Shall have permanently lubricated sealed bearings.
- d. Shall have inherent thermal overload protection.
- e. Shall have an automatic reset feature.

I. (23 81 19.13.I.) Coils

1. Standard Aluminum Fin/Copper Tube Coils:

- a. Standard evaporator and condenser coils shall have aluminum lanced plate fins mechanically bonded to seamless internally grooved copper tubes with all joints brazed.

- b. Evaporator coils shall be leak tested to 150 psig, pressure tested to 450 psig, and qualified to UL 1995 burst test at 1775 psig.
  - c. Condenser coils shall be leak tested to 150 psig, pressure tested to 650 psig, and qualified to UL 1995 burst test at 1980 psig.
2. Optional Pre-Coated Aluminum-Fin Condenser Coils (3-phase models only):
- a. Shall have a durable epoxy-phenolic coating to provide protection in mildly corrosive coastal environments.
  - b. Coating shall be applied to the aluminum fin stock prior to the fin stamping process to create an inert barrier between the aluminum fin and copper tube.
  - c. Epoxy-phenolic barrier shall minimize galvanic action between dissimilar metals.
  - d. Corrosion durability of fin stock shall be confirmed through testing to be no less than 1000 hours salt spray per ASTM B117-90.
  - e. Corrosion durability of fin stock shall be confirmed through testing to have no visible corrosion after 48 hour immersion in a room temperature solution of 5% salt, 1% acetic acid.
  - f. Fin stock coating shall pass 2000 hours of the following: one week exposure in the prohesion chamber followed by one week of accelerated ultraviolet light testing. Prohesion chamber: the solution shall contain 3.5% sodium chloride and 0.35% ammonium sulfate. The exposure cycle is one hour of salt fog application at ambient followed by one hour drying at 95°F (35°C).
3. Optional Copper-Fin Evaporator and Condenser Coils (3-phase models only):
- a. Shall be constructed of copper fins mechanically bonded to copper tubes and copper tube sheets.
  - b. Galvanized steel tube sheets shall not be acceptable.
  - c. A polymer strip shall prevent coil assembly from contacting the sheet metal coil pan to minimize potential for galvanic corrosion between coil and pan.
4. Optional E-Coated Aluminum-Fin Evaporator and Condenser Coils (3-phase models only):
- a. Shall have a flexible epoxy polymer coating uniformly applied to all coil surface areas without material bridging between fins.
  - b. Coating process shall ensure complete coil encapsulation of tubes, fins and headers.
  - c. Color shall be high gloss black with gloss per ASTM D523-89.
  - d. Uniform dry film thickness from 0.8 to 1.2 mil on all surface areas including fin edges.
- e. Superior hardness characteristics of 2H per ASTM D3363-92A and cross-hatch adhesion of 4B-5B per ASTM D3359-93.
  - f. Impact resistance shall be up to 160 in.-lb (ASTM D2794-93).
  - g. Humidity and water immersion resistance shall be up to minimum 1000 and 250 hours respectively (ASTM D224-92 and ASTM D870-92).
  - h. Corrosion durability shall be confirmed through testing to be no less than 6000 hours salt spray per ASTM B117-90.
5. Optional E-Coated Aluminum-Fin, Aluminum Tube Condenser Coils:
- a. Shall have a flexible epoxy polymer coating uniformly applied to all coil external surface areas without material bridging between fins or louvers.
  - b. Coating process shall ensure complete coil encapsulation, including all exposed fin edges.
  - c. E-coat thickness of 0.8 to 1.2 mil with top coat having a uniform dry film thickness from 1.0 to 2.0 mil on all external coil surface areas, including fin edges, shall be provided.
  - d. Shall have superior hardness characteristics of 2H per ASTM D3363-00 and cross-hatch adhesion of 4B-5B per ASTM D3359-02.
  - e. Shall have superior impact resistance with no cracking, chipping or peeling per NSF/ANSI 51-2002 Method 10.2.
- J. (23 81 19.13.J) Refrigerant Components
1. Refrigerant circuit shall include the following control, safety, and maintenance features:
    - a. Thermostatic Expansion Valve (TXV) shall help provide optimum performance across the entire operating range. Shall contain removable power element to allow change out of power element and bulb without removing the valve body.
    - b. Refrigerant filter drier.
    - c. Service gauge connections on suction and discharge lines.
    - d. Pressure gauge access through a specially designed access port in the top panel of the unit.
  2. There shall be gauge line access port in the skin of the rooftop, covered by a black, removable plug.
    - a. The plug shall be easy to remove and replace.
    - b. When the plug is removed, the gauge access port shall enable maintenance personnel to route their pressure gauge lines.

- c. This gauge access port shall facilitate correct and accurate condenser pressure readings by enabling the reading with the compressor access panel on.
  - d. The plug shall be made of a leak proof, UV-resistant, composite material.
3. Compressors:
- a. Unit shall use one fully hermetic, scroll compressor for each independent refrigeration circuit.
  - b. Models shall be available with single compressor/single stage cooling designs on 04-07 models, single compressor/2-stage cooling on 07 size, and 2 compressor/2-stage cooling models on 08-12 sizes.
  - c. Compressor motors shall be cooled by refrigerant gas passing through motor windings.
  - d. Compressors shall be internally protected from high discharge temperature conditions.
  - e. Compressors shall be protected from an over-temperature and over-amperage conditions by an internal, motor overload device.
  - f. Compressor shall be factory mounted on rubber grommets.
  - g. Compressor motors shall have internal line break thermal, current overload and high pressure differential protection.
  - h. Crankcase heaters shall be utilized on all models to protect compressor with specific refrigerant charge.
- K. (23 81 19.13.K) Filter Section
- 1. Filters access is specified in the unit cabinet section of this specification.
  - 2. Filters shall be held in place by a preformed slide out filter tray, facilitating easy removal and installation.
  - 3. Shall consist of factory-installed, low velocity, throw-away 2-in. thick fiberglass filters.
  - 4. Filters shall be standard, commercially available sizes.
  - 5. Only one size filter per unit is allowed.
- L. (23 81 19.13.L) Evaporator Fan and Motor
- 1. Evaporator fan motor:
    - a. Shall have permanently lubricated bearings.
    - b. Shall have inherent automatic-reset thermal overload protection or circuit breaker.
    - c. Shall have a maximum continuous bhp rating for continuous duty operation; no safety factors above that rating shall be required.
  - 2. Belt-driven evaporator fan:
    - a. Belt drive shall include an adjustable-pitch motor pulley and belt break protection system.
    - b. Shall use rigid pillow block bearing system with lubricate fittings at are accessible or lubrication line.
- c. Blower fan shall be double-inlet type with forward-curved blades.
  - d. Shall be constructed from steel with a corrosion resistant finish and dynamically balanced.
  - e. Standard on all 04-14 size models with Humidi-MiZer option.
- M. (23 81 19.13.M) Condenser Fans and Motors
- 1. Condenser fan motors:
    - a. Shall be a totally enclosed motor.
    - b. Shall use permanently lubricated bearings.
    - c. Shall have inherent thermal overload protection with an automatic reset feature.
    - d. Shall use a shaft down design on all sizes.
  - 2. Condenser fans:
    - a. Shall be a direct driven propeller type fan.
    - b. Shall have aluminum blades riveted to corrosion resistant steel spiders and shall be dynamically balanced.
- N. (23 81 19.13.N) Special Features Options and Accessories
- 1. EnergyX<sup>®</sup> and Economizer:
    - a. System Description:
      - 1) One-piece EnergyX (Energy Recovery Ventilation) unit is an electrically controlled ventilation air pre-conditioner utilizing an AHRI 1060 certified Energy Recovery Cassette to reduce the cooling and heating loads placed on the primary HVAC unit by untreated outdoor air. Building exhaust air shall be introduced to the EnergyX unit through ductwork. Unit shall be designed as a factory-installed option to be used with WeatherMaster 48HC units for use in vertical return applications only.
    - b. Quality Assurance:
      - 1) Unit shall be designed in accordance with UL Standard 1995.
      - 2) Energy Recovery unit shall be ETL tested and certified.
      - 3) Rooftop unit and Energy Recovery unit shall be ETL certified as one single system.
      - 4) Roof curb or curb extension shall be designed to conform to NRCA Standards.
      - 5) Insulation and adhesive shall meet NFPA 90A requirements for flame spread and smoke generation.
      - 6) Unit casing shall be capable of withstanding ASTM No. 141 (Method 6061) 500-hour salt spray test.
      - 7) Unit shall contain AHRI 1060 certified Energy Recovery Cassette.
      - 8) Unit leakage rates shall be capable of meeting ASHRAE Standard 62.1 requirements for use of class-2 exhaust with class-1 ventilation air.

c. Products:

- 1) Equipment (Standard): The EnergyX unit shall be a factory assembled, single piece unit. Contained within the unit enclosure shall be all factory wiring with a single, pre-determined point of power input and a single point of 24-volt control wiring.

d. Unit Cabinet:

- 1) Unit cabinet shall be constructed of galvanized steel coated with a pre-painted baked enamel finish.
- 2) All models shall have hoods installed over outside air intake and exhaust openings. Outside air hood shall have aluminum water entrainment filters.
- 3) All models have 1-in., 2 pound density fiberglass insulation.
- 4) Hinged access doors with compression latches shall be provided on all units for access to fans and filters. Hinged doors shall be provided with at least one handle capable of being locked.
- 5) Exhaust air stream shall have back-draft dampers to prevent air penetration during off cycles.
- 6) Holes shall be provided in the base rails for rigging shackles to facilitate overhead rigging.

e. Blowers:

- 1) Blowers shall be direct drive with variable speed motors.
- 2) Blower wheel shall be made of steel with a corrosion resistant finish. It shall be dynamically balanced, double-inlet type with backward-curved blades.
- 3) Blower shall be mounted on neoprene vibration isolation pads.
- 4) Motor shall be high efficiency and have thermal overload protection.

f. Filter Section:

- 1) Standard filter section shall accept commercially available, 2-in. pleated filter(s).

g. Controls and Safeties:

- 1) The EnergyX unit shall operate in conjunction with rooftop unit fan.

h. Electrical Requirements:

- 1) All unit power wiring shall enter unit cabinet at a single location.

i. Energy Recovery Cassette:

- 1) The energy recovery media shall have a minimum of 70% effectiveness at nominal unit airflow.
- 2) Energy wheel performance shall be AHRI Standard 1060 Certified and bear the AHRI Certified Product Seal.
- 3) The energy recovery cassette shall be an UL Recognized component for electrical and fire safety.

- 4) The wheel shall be coated with silica gel desiccant, permanently bonded without the use of binders or adhesives.

- 5) Coated wheels shall be washable with detergent or alkaline coil cleaner and water.

- 6) The silica gel shall not dissolve or deliquesce in the presence of water or high humidity.

- 7) The substrate shall be made of a light-weight polymer and shall not degrade or require additional coatings for application in coastal environments.

- 8) The wheel polymer layers shall be wound continuously with one flat and one structured layer in an ideal parallel plate geometry providing laminar flow and minimum pressure drop.

- 9) The polymer layers shall be captured in a stainless steel wheel frame or aluminum and stainless steel segment frames that provide a rigid and self-supporting matrix.

- 10) Energy recovery wheels greater than 19 inches in diameter shall be provided with removable wheel segments.

- 11) Wheel frame shall be a welded hub, spoke and rim assembly of stainless, plated, and or coated steel and shall be self supporting without the wheel segments in place.

- 12) Wheel segments shall be removable without the use of tools to facilitate maintenance and cleaning.

- 13) Wheel rim shall be continuous rolled stainless steel and the wheel shall be connected to the shaft by means of taper locks.

- 14) Wheel bearings shall provide an L-10 life of 400,000 hours.

- 15) Drive belts of stretch urethane shall be provided for wheel rim drive without the need for external tensioners or adjustment.

j. Supply and Exhaust Air Frost Control Option:

- 1) Factory-installed frost protection module shall sense pressure differential across the energy recovery cassette.

- 2) Supply blower shall be shut-off if the pressure differential across the energy recovery cassette exceeds an adjustable set point. Blower shall remain off for an adjustable time period.

- 3) Exhaust blower and wheel shall remain in operation in order to remove any frost build-up on the wheel.

k. EnergyX Maintenance Indicator Package:

- 1) A factory-installed switch shall monitor EnergyX blowers and wheel motor amp

- draw and send a signal to field-supplied 24-v indicator upon amperage surge that maintenance required.
- l. Filter Maintenance Indicator:
    - 1) A factory-installed differential pressure switch shall measure pressure drop across the outside air filter and activate a field-supplied 24-v indicator when airflow is restricted. It shall not interrupt EnergyX operation. Switch set point shall be adjustable.
  - m. EnergyX Free Cooling with Enthalpy and Stop/Jog Control:
    - 1) An enthalpy sensor shall prevent the wheel from rotating if the outside air conditions are acceptable for free cooling. Both exhaust and supply blowers will remain on.
    - 2) Stop-Jog-Control shall energize the wheel periodically during the free cooling operation of the EnergyX unit to prevent dirt build-up on the wheel.
  - n. Economizer Option:
    - 1) The economizer shall be integrated in the energy recovery module and shall allow air to bypass the energy recovery wheel for free cooling and fail safe operation. Tilting wheel mechanisms shall not be allowed.
    - 2) The economizer damper shall be motorized with factory installed, 24-volt Belimo actuator.
    - 3) The EnergyX unit shall be capable of using the economizer in a free cooling operation.
    - 4) The economizer shall utilize enthalpy sensor controls when in the economizer mode.
  - o. CO<sub>2</sub> Sensor:
    - 1) The modulating airflow energy recovery unit shall be capable of incorporating a CO<sub>2</sub> sensor for use with Demand Controlled Ventilation.
    - 2) The CO<sub>2</sub> sensor shall connect to the base rooftop unit's digital controller.
    - 3) The modulating airflow energy recovery unit shall use at a minimum, a high and low CFM airflow set point when a CO<sub>2</sub> sensor is used.
  - p. Roof Curb Extension (HC04-14 sizes with EnergyX) Accessory for use with EnergyX units:
    - 1) The energy recovery module shall use the standard rooftop unit rooftop curb.
    - 2) Rooftop extensions, support rails or other devices that come in contact with the roof surface to support the energy recovery module shall not be allowed.
    - 3) A horizontal adapter curb shall be used to convert vertical return air applications into horizontal return air applications. The supply airflow shall be convertible via the base rooftop unit operation and restrictions.
  2. Staged Air Volume System (SAV™) for 2-stage cooling models only:
    - a. Evaporator fan motor:
      - 1) Shall have permanently lubricated bearings.
      - 2) Shall have a maximum continuous bhp rating for continuous duty operation; no safety factors above that rating.
      - 3) Shall be Variable Frequency duty and 2-speed control.
      - 4) Shall contain motor shaft grounding ring to prevent electrical bearing fluting damage by safely diverting harmful shaft voltages and bearing currents to ground.
    3. Variable Frequency Drive (VFD). Only available on 2-speed indoor fan motor option (SAV):
      - a. Factory-supplied VFDs qualify, through ABB for a 12-month warranty from date of commissioning or 18 months from date of sale, whichever occurs first.
      - b. Shall be installed inside the unit cabinet, mounted, wired and tested.
      - c. Shall contain Electromagnetic Interference (EMI) frequency protection.
      - d. Insulated Gate Bi-Polar Transistors (IGBT) used to produce the output pulse width modulated (PWM) waveform, allowing for quiet motor operation.
      - e. Self diagnostics with fault and power code LED indicator. Field accessory Display Kit available for further diagnostics and special setup applications.
      - f. RS485 capability standard.
      - g. Electronic thermal overload protection.
      - h. 5% swinging chokes for harmonic reduction and improved power factor.
      - i. All printed circuit boards shall be conformal coated.
    4. Integrated EconoMi\$er® IV, EconoMi\$er 2, and EconoMi\$er X Low Leak Rate Models. (Factory-installed on 3-phase models only. Field installed on all 3 and 1-phase models.)
      - a. Integrated, gear driven opposing modulating blade design type capable of simultaneous economizer and compressor operation.
      - b. Independent modules for vertical or horizontal return configuration shall be available. Vertical return modules shall be available as a factory-installed option.

- c. Damper blades shall be galvanized steel with composite gears. Plastic or composite blades on intake or return shall not be acceptable.
  - d. Shall include all hardware and controls to provide free cooling with outdoor air when temperature and/or humidity are below set-points.
  - e. Shall be equipped with gear driven dampers for both the outdoor ventilation air and the return air for positive air stream control.
  - f. Low leak rate models shall be equipped with dampers not to exceed 2% leakage at 1 in. wg pressure differential.
  - g. Economizer controller on EconoMi\$er IV models shall be Honeywell W7212 that provides:
    - 1) Combined minimum and DCV maximum damper position potentiometers with compressor staging relay.
    - 2) Functions with solid state analog enthalpy or dry bulb changeover control sensing.
    - 3) LED indicators for: when free cooling is available, when module is in DCV mode, when exhaust fan contact is closed.
  - h. Economizer controller on EconoMi\$er X models shall be the Honeywell W7220 that provides:
    - 1) 2-line LCD interface screen for setup, configuration and troubleshooting.
    - 2) On-board Fault Detection and Diagnostics (FDD) that senses and alerts when the economizer is not operating properly, per California Title 24.
    - 3) Sensor failure loss of communication identification.
    - 4) Automatic sensor detection.
    - 5) Capabilities for use with multiple-speed indoor fan systems.
    - 6) Utilize digital sensors: Dry bulb and Enthalpy.
  - i. Economizer controller on EconoMi\$er 2 models with PremierLink™ controller shall be 4-20mA design and controlled by the PremierLink controller. PremierLink controller does not comply with California Title 24 Fault Detection and Diagnostic (FDD) requirements.
  - j. Economizer controller on EconoMi\$er 2 models with RTU Open controller shall be a 4-20mA design controlled directly by the RTU Open controller. RTU Open controller meets California Title 24 Fault Detection and Diagnostic (FDD) requirements.
  - k. Shall be capable of introducing up to 100% outdoor air.
  - l. Shall be equipped with a barometric relief damper capable of relieving up to 100% return air and contain seals that meet ASHRAE 90.1-2016 and IECC-2015 requirements.
  - m. Shall be designed to close damper(s) during loss-of-power situations with spring return built into motor.
  - n. Dry bulb outdoor air temperature sensor shall be provided as standard. Enthalpy sensor is also available on factory-installed only. Outdoor air sensor setpoint shall be adjustable and shall range from 40 to 100°F (4 to 38°C). Additional sensor options shall be available as accessories.
  - o. The economizer controller shall also provide control of an accessory power exhaust unit function. Factory set at 100%, with a range of 0% to 100%.
  - p. The economizer shall maintain minimum airflow into the building during occupied period and provide design ventilation rate for full occupancy.
  - q. Dampers shall be completely closed when the unit is in the unoccupied mode.
  - r. Economizer controller shall accept a 2 to 10 Vdc CO<sub>2</sub> sensor input for IAQ/DCV control. In this mode, dampers shall modulate the outdoor air damper to provide ventilation based on the sensor input.
  - s. Compressor lockout temperature on W7220 is adjustable from -45°F to 80°F, set at a factory default of 32°F. Others shall open at 35°F (2°C) and close at 50°F (10°C).
  - t. Actuator shall be direct coupled to economizer gear. No linkage arms or control rods shall be acceptable.
  - u. Economizer controller shall provide indications when in free cooling mode, in the DCV mode, or the exhaust fan contact is closed.
5. Integrated EconoMi\$er2, and EconoMi\$er X Ultra Low Leak Rate Models. (Factory-installed on 3 phase models only. Field-installed on all 3 and 1 phase models):
- a. Integrated, gear driven opposing modulating blade design type capable of simultaneous economizer and compressor operation.
  - b. Independent modules for vertical or horizontal return configuration shall be available. Vertical return modules shall be available as a factory-installed option.
  - c. Damper blades shall be galvanized steel with composite gears. Plastic or composite blades on intake or return shall not be acceptable.
  - d. Shall include all hardware and controls to provide free cooling with outdoor air when temperature and/or humidity are below set-points.

- e. Shall be equipped with gear driven dampers for both the outdoor ventilation air and the return air for positive air stream control.
  - f. Ultra low leak design meets California Title 24 section 140.4 and, ASHRAE 90.1-2016 and IECC-2015 requirements for 4 cfm per sq. ft. on the outside air dampers and 10 cfm per sq. ft. on the return dampers.
  - g. Economizer controller on EconoMi\$er X models shall be the Honeywell W7220 that provides:
    - 1) 2-line LCD interface screen for setup, configuration and troubleshooting.
    - 2) On-board Fault Detection and Diagnostics (FDD) that senses and alerts when the economizer is not operating properly, per California Title 24.
    - 3) Sensor failure loss of communication identification.
    - 4) Automatic sensor detection.
    - 5) Capabilities for use with multiple-speed indoor fan systems.
    - 6) Utilize digital sensors: Dry bulb and Enthalpy.
  - h. Economizer controller on EconoMi\$er 2 models with RTU Open controller shall be a 4-20mA design controlled directly by the RTU Open controller. RTU Open controller meets California Title 24 Fault Detection and Diagnostic (FDD) requirements.
  - i. Shall be capable of introducing up to 100% outdoor air.
  - j. Shall be equipped with a barometric relief damper capable of relieving up to 100% return air and contain seals that meet ASHRAE 90.1-2016 and IECC-2015 requirements.
  - k. Shall be designed to close damper(s) during loss-of-power situations with spring return built into motor.
  - l. Dry bulb outdoor air temperature sensor shall be provided as standard. Enthalpy sensor is also available on factory-installed only. Outdoor air sensor setpoint shall be adjustable and shall range from 40°F to 100°F (4°C to 38°C). Additional sensor options shall be available as accessories.
  - m. The economizer controller shall also provide control of an accessory power exhaust unit function. Factory set at 100%, with a range of 0% to 100%.
  - n. The economizer shall maintain minimum air-flow into the building during occupied period and provide design ventilation rate for full occupancy.
  - o. Dampers shall be completely closed when the unit is in the unoccupied mode.
  - p. Economizer controller shall accept a 2-10 Vdc CO<sub>2</sub> sensor input for IAQ/DCV control. In this mode, dampers shall modulate the outdoor air damper to provide ventilation based on the sensor input.
  - q. Compressor lockout temperature on W7220 is adjustable from -45°F to 80°F, set at a factory default of 32°F. Others shall open at 35°F (2°C) and closes at 50°F (10°C).
  - r. Actuator shall be direct coupled to economizer gear. No linkage arms or control rods shall be acceptable.
  - s. Economizer controller shall provide indications when in free cooling mode, in the DCV mode, or the exhaust fan contact is closed.
6. Two-Position Damper (Factory-installed on 3 Phase Models Only. Field-installed on all 3 and 1 Phase Models)
- a. Damper shall be a Two-Position Damper. Damper travel shall be from the full closed position to the field adjustable %-open setpoint.
  - b. Damper shall include adjustable damper travel from 25% to 100% (full open).
  - c. Damper shall include single or dual blade, gear driven dampers and actuator motor.
  - d. Actuator shall be direct coupled to damper gear. No linkage arms or control rods shall be acceptable.
  - e. Damper will admit up to 100% outdoor air for applicable rooftop units.
  - f. Damper shall close upon indoor (evaporator) fan shutoff and/or loss of power.
  - g. The damper actuator shall plug into the rooftop unit's wiring harness plug. No hard wiring shall be required.
  - h. Outside air hood shall include aluminum water entrainment filter.
  - i. Not available with Staged Air Volume (SAV) models.
7. Manual Damper:
- a. Manual damper package shall consist of damper, air inlet screen, and rain hood which can be preset to admit up to 25 or 50% outdoor air for year round ventilation.
  - b. Not available with Staged Air Volume (SAV) models.
8. Humidi-MiZer® Adaptive Dehumidification System (3-phase models only):
- a. The Humidi-MiZer adaptive dehumidification system shall be factory-installed and shall provide greater dehumidification of the occupied space by two modes of

dehumidification operations in addition to its normal design cooling mode:

- 1) Subcooling mode further sub cools the hot liquid refrigerant leaving the condenser coil when both temperature and humidity in the space are not satisfied.
  - 2) Hot gas reheat mode shall mix a portion of the hot gas from the discharge of the compressor with the hot liquid refrigerant leaving the condenser coil to create a two-phase heat transfer in the system, resulting in a neutral leaving air temperature when only humidity in the space is not satisfied.
  - 3) Includes head pressure controller.
9. Head Pressure Control Package (Motormaster®):
- a. Controller shall control coil head pressure by condenser-fan speed modulation or condenser-fan cycling and wind baffles.
  - b. Shall consist of solid-state control and condenser-coil temperature sensor to maintain condensing temperature at outdoor ambient temperatures down to -20°F (-29°C).
10. Low Ambient Controller (Factory-installed only):
- a. Controller shall control coil head pressure by condenser-fan speed modulation or condenser-fan cycling and wind baffles.
  - b. Shall consist of solid-state control and condenser-coil temperature sensor to maintain condensing temperature at outdoor ambient temperatures down to 0°F (-18°C). (Not available on 11 size models as standard unit cooling operation down to 0°F /-18°C).
11. Propane Conversion Kit:
- a. Package shall contain all the necessary hardware and instructions to convert a standard natural gas unit for use with liquefied propane, up to 2000 ft (610m) elevation.
  - b. Additional accessory kits may be required for applications above 2000 ft (610m) elevation.
12. Flue Shield (04-12 models only):
- a. Flue shield shall provide protection from the hot sides of the gas flue hood.
13. Condenser Coil Hail Guard Assembly (Factory-installed option on 3-phase models. Field-installed on all 3 and 1 phase models):
- a. Shall protect against damage from hail.
  - b. Shall be of louvered style.
14. Unit-Mounted, Non-Fused Disconnect Switch:
- a. Switch shall be factory-installed, internally mounted.
  - b. National Electric Code (NEC) and UL or ETL approved non-fused switch shall provide unit power shutoff.
- c. Shall be accessible from outside the unit.
  - d. Shall provide local shutdown and lockout capability.
  - e. Sized only for the unit as ordered from the factory. Does not accommodate field-installed devices.
15. HACR Breaker:
- a. These manual reset devices provide overload and short circuit protection for the unit. Factory wired and mounted with the units, with access cover to help provide environmental protection. On 575V applications, HACR breaker can only be used with WYE power distribution systems. Use on Delta power distribution systems is prohibited.
  - b. Sized only for the unit as ordered from the factory. Does not accommodate field-installed devices.
16. Convenience Outlet:
- a. Powered convenience outlet. (Not available on single phase models):
    - 1) Outlet shall be powered from main line power to the rooftop unit.
    - 2) Outlet shall be powered from line side or load side of disconnect by installing contractor, as required by code. If outlet is powered from load side of disconnect, unit electrical ratings shall be UL certified and rated for additional outlet amperage.
    - 3) Outlet shall be factory-installed and internally mounted with easily accessible 115-v female receptacle.
    - 4) Outlet shall include 15 amp GFI receptacles with independent fuse protection.
    - 5) Voltage required to operate convenience outlet shall be provided by a factory-installed step down transformer.
    - 6) Outlet shall be accessible from outside the unit.
    - 7) Outlet shall include a field-installed "Wet in Use" cover.
  - b. Factory-installed non-powered convenience outlet:
    - 1) Outlet shall be powered from a separate 115-120v power source.
    - 2) A transformer shall not be included.
    - 3) Outlet shall be factory-installed and internally mounted with easily accessible 115-v female receptacle.
    - 4) Outlet shall include 15 amp GFI receptacles.
    - 5) Outlet shall be accessible from outside the unit.
    - 6) Outlet shall include a field-installed "Wet in Use" cover.



- c. Field-installed non-powered convenience outlet:
  - 1) Outlet shall be powered from a separate 115-120v power source.
  - 2) A transformer shall not be included.
  - 3) Outlet shall be field-installed and internally mounted with easily accessible 115-v female receptacle.
  - 4) Outlet shall include 20 amp GFI receptacles. This kit provides a flexible installation method which allows code compliance for height requirements of the GFCI outlet from the finished roof surface as well as the capability to relocate the outlet to a more convenient location.
  - 5) Outlet shall be accessible from outside the unit.
- d. Outlet shall include a field-installed "Wet in Use" cover.
- 17. Flue Discharge Deflector:
  - a. Flue discharge deflector shall direct unit exhaust vertically instead of horizontally.
  - b. Deflector shall be defined as a "natural draft" device by the National Fuel and Gas (NFG) code.
- 18. Thru-the-Base Connectors:
  - a. Kits shall provide connectors to permit gas and electrical connections to be brought to the unit through the unit basepan.
  - b. Minimum of four connection locations per unit.
- 19. Propeller Power Exhaust:
  - a. Power exhaust shall be used in conjunction with an integrated economizer.
  - b. Independent modules for vertical or horizontal return configurations shall be available.
  - c. Horizontal power exhaust shall be mounted in return ductwork.
  - d. Power exhaust shall be controlled by economizer controller operation. Exhaust fans shall be energized when dampers open past the 0 to 100% adjustable setpoint on the economizer control.
- 20. Roof Curbs (Vertical):
  - a. Full perimeter roof curb with exhaust capability providing separate air streams for energy recovery from the exhaust air without supply air contamination.
  - b. Formed galvanized steel with wood nailer strip and shall be capable of supporting entire unit weight.
  - c. Permits installation and securing of ductwork to curb prior to mounting unit on the curb.
- 21. High Altitude Gas Conversion Kit:

Package shall contain all the necessary hardware and instructions to convert a standard natural gas unit to operate from 2000 to 7000 ft (610 to 2134m) elevation with natural gas or from 0 to 7000 ft (900 to 2134m) elevation with liquefied propane.
- 22. Outdoor Air Enthalpy Sensor:

The outdoor air enthalpy sensor shall be used to provide single enthalpy control. When used in conjunction with a return air enthalpy sensor, the unit will provide differential enthalpy control. The sensor allows the unit to determine if outside air is suitable for free cooling.
- 23. Return Air Enthalpy Sensor:

The return air enthalpy sensor shall be used in conjunction with an outdoor air enthalpy sensor to provide differential enthalpy control.
- 24. Indoor Air Quality (CO<sub>2</sub>) Sensor:
  - a. Shall be able to provide demand ventilation indoor air quality (IAQ) control.
  - b. The IAQ sensor shall be available in duct mount, wall mount, or wall mount with LED display. The setpoint shall have adjustment capability.
- 25. Smoke Detectors (factory-installed only):
  - a. Shall be a four-wire controller and detector.
  - b. Shall be environmental compensated with differential sensing for reliable, stable, and drift-free sensitivity.
  - c. Shall use magnet-activated test/reset sensor switches.
  - d. Shall have tool-less connection terminal access.
  - e. Shall have a recessed momentary switch for testing and resetting the detector.
  - f. Controller shall include:
    - 1) One set of normally open alarm initiation contacts for connection to an initiating device circuit on a fire alarm control panel.
    - 2) Two Form-C auxiliary alarm relays for interface with rooftop unit or other equipment.
    - 3) One Form-C supervision (trouble) relay to control the operation of the Trouble LED on a remote test/reset station.
    - 4) Capable of direct connection to two individual detector modules.
    - 5) Can be wired to up to 14 other duct smoke detectors for multiple fan shut-down applications
- 26. Horn/Strobe Annunciator:
  - a. Provides an audible/visual signaling device for use with factory-installed option or field-installed accessory smoke detectors.

## Guide specifications (cont)

- 1) Requires installation of a field-supplied 24-v transformer suitable for 4.2 VA (AC) or 3.0 VA (DC) per horn/strobe accessory.
  - 2) Requires field-supplied electrical box, North American 1-gang box, 2-in. (51 mm) x 4-in. (102 mm).
  - 3) Shall have a clear colored lens.
27. Winter Start Kit:
- a. Shall contain a bypass device around the low pressure switch.
  - b. Shall be required when mechanical cooling is required down to 25°F (-4°C).
  - c. Shall not be required to operate on an economizer when below an outdoor ambient of 40°F (4°C).
28. Time Guard:
- a. Shall prevent compressor short cycling by providing a 5-minute delay ( $\pm 2$  minutes) before restarting a compressor after shut-down for any reason.
  - b. One device shall be required per compressor.
29. Condensate Overflow Switch (for units with electro-mechanical controls only):
- This sensor and related controller monitors the condensate level in the drain pan and shuts down compression operation when overflow conditions occur. It includes:
- a. Indicator light — solid red (more than 10 seconds on water contact — compressors disabled), blinking red (sensor disconnected).
  - b. 10 second delay to break — eliminates nuisance trips from splashing or waves in pan (sensor needs 10 seconds of constant water contact before tripping).
- c. Disables the compressor(s) operation when condensate plug is detected, but still allows fans to run for economizer.
30. Hinged Access Panels:
- a. Shall provide easy access through integrated quarter turn latches.
  - b. Shall be on major panels of — filter, control box, fan motor and compressor
31. Display Kit for Variable Frequency Drive:
- a. Kit allows the ability to access the VFD controller programs to provide special setup capabilities and diagnostics.
  - b. Kit contains display module and communication cable.
  - c. Display Kit can be permanently installed in the unit or used on any SAV™ system VFD controller as needed.
32. Foil faced insulation:
- a. Throughout unit cabinet air stream, non-fibrous and cleanable foil faced insulation is used.
33. California OSHPD Seismic Certification Label:
- a. Units meet the seismic capacity requirements of the International Code Council Evaluation Service (ICC-ES) document AC156 (Acceptance Criteria for Seismic Qualification by Shake-Table Testing of Nonstructural Components and Systems) and per International Building Code (IBC 2009) at an SDS (g) value of 2.00 z/h=1.0, Ip=1.5 and certified by independent structural engineers.
  - b. Units shall include a certification label that meets the CA OSHPD Special Seismic Certification pre-approval labeling requirements on the external chassis of the unit.