

VelociRAX

Rack'em Fast

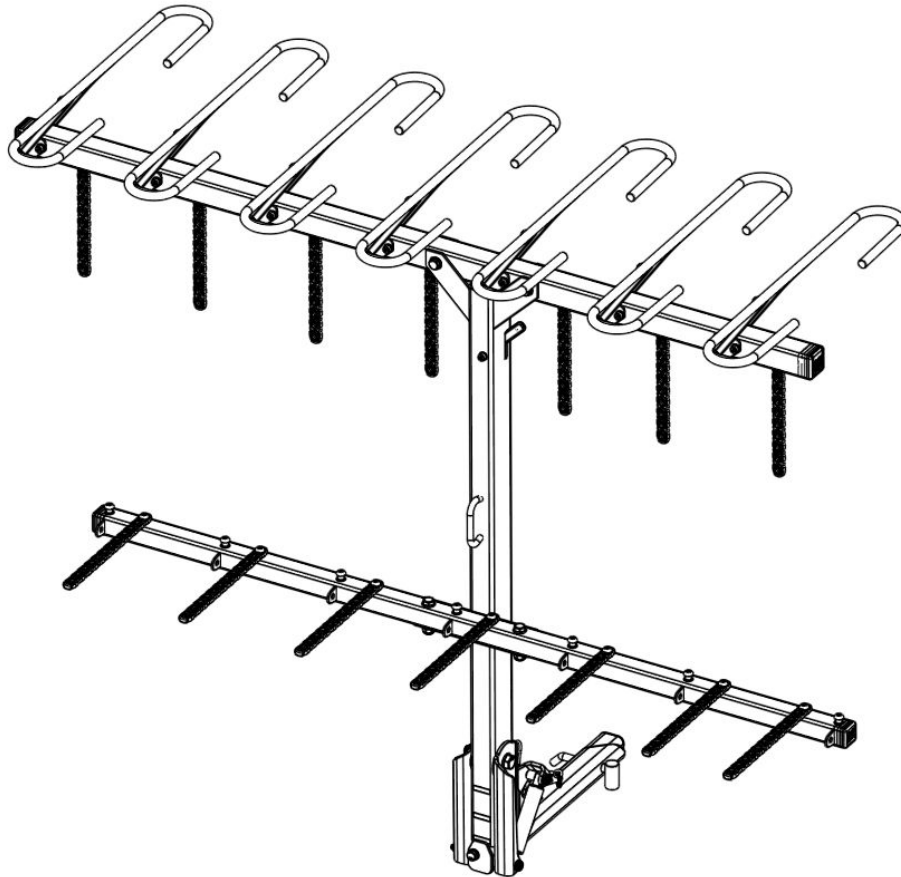

Latest instructions
and videos:

[www.velocirax.com/
pages/assembly](http://www.velocirax.com/pages/assembly)

Assembly and Instruction Manual

READ ALL INSTRUCTIONS BEFORE ASSEMBLY OR USE

Rack'em on your vehicle AND Rack'em in the garage



WARNINGS AND PRECAUTIONS



READ ALL INSTRUCTIONS BEFORE ASSEMBLY OR USE

- **RACK CAPACITY - 230 lbs / 104 kg TOTAL BIKE CAPACITY, 55 lbs / 25 kg MAX CAPACITY PER BIKE SLOT**
- **USE CLASS III 2" (50 MM) HITCH WITH TONGUE CAPACITY OF 500 lbs (227KG)**
- **DO NOT USE WITHOUT A PROPERLY INSTALLED HITCH PIN AND SECURED ANTI-RATTLE WEDGE.**
- **DO NOT HINGE A LOADED VELOCIRAX WITHOUT HINGE DAMPERS ENGAGED.**
- **DO NOT DRIVE VEHICLE WHILE THE VELOCIRAX IS IN THE HINGED OR LOADING POSITION.**
- **DO NOT TAKE VEHICLE THROUGH AUTOMATIC CAR WASH WITH RACK ON VEHICLE**
- **CONFIRM BOTH FRONT AND BACK TIRES ARE SECURED TIGHTLY WITH VELOCIRAX STRAPS FOR TRANSPORTING.**
- **PLACE THE STOP PIN IN THE NO HINGE POSITION (POSITION A) WHILE TRANSPORTING BICYCLES.**
- **KNOW YOUR VEHICLE / LOADED BIKE HEIGHT BEFORE YOU DRIVE INTO A PARKING GARAGE OR YOUR OWN GARAGE. FRONT TIRES EXTEND ABOVE MANY VEHICLES.**
- **RVs/TRAILERS REQUIRE A CLASS III 2-INCH HITCH RECEIVER WITH CAPACITY OF 500 lbs MINIMUM. BUMPER HITCHES, EXTENSION HITCHES AND CANTILEVERED HITCHES ARE INADEQUATE.**

*Veloci***RAX**

RACK DIAGRAM

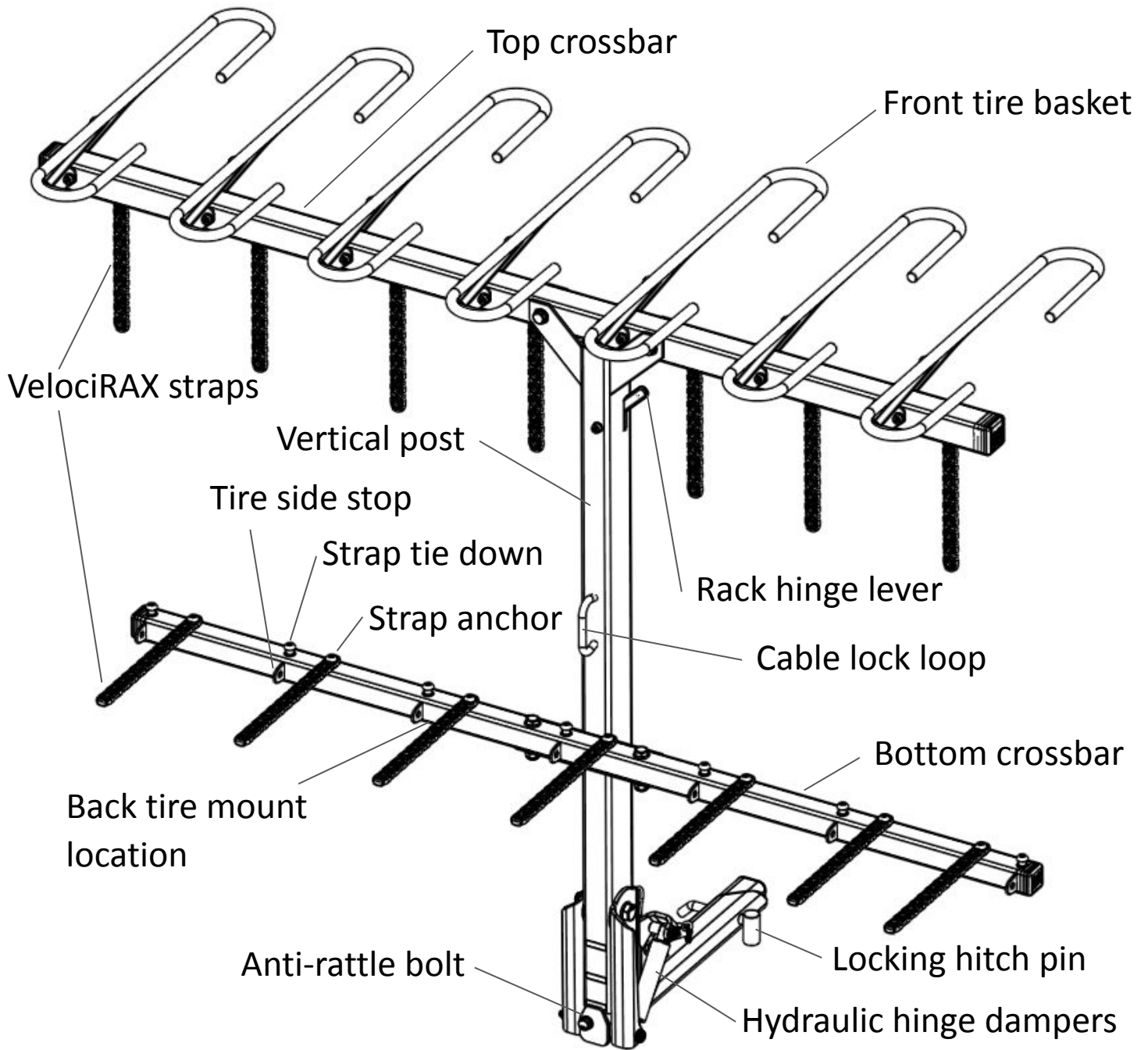

Hinge Assembly

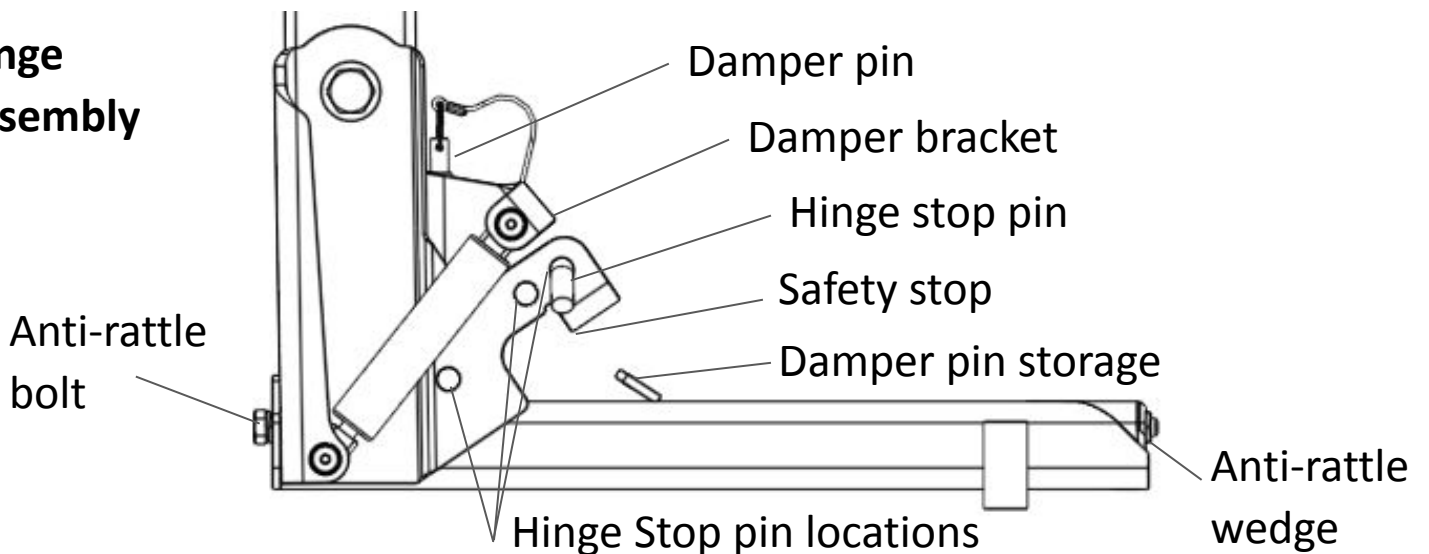

PACKAGE CONTENTS

Box 1. Top and Bottom Crossbars and Garage Mount

1. (1) Top Crossbar
2. (1) Bottom Crossbar
3. Assembly hardware
 - a. (2) 3-1/8" (79 mm) bolts
 - b. (2) 2-9/16" (65 mm) bolts
 - c. (8) washers
 - d. (4) nylock nuts
4. Garage mount bar
5. Garage mount hardware

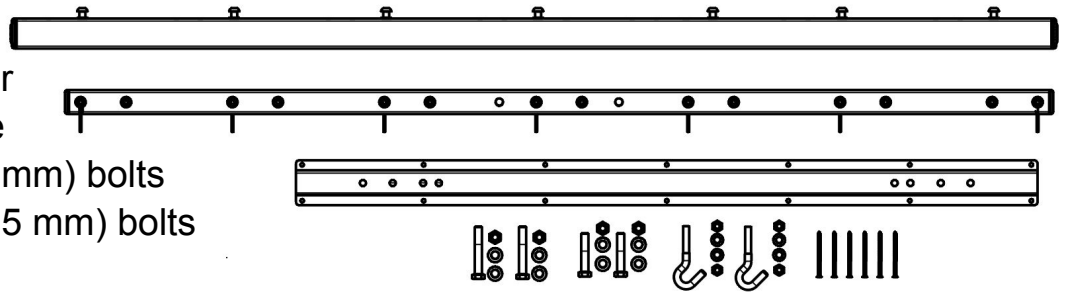

Box 2. Tire Baskets and VelociRAX Straps

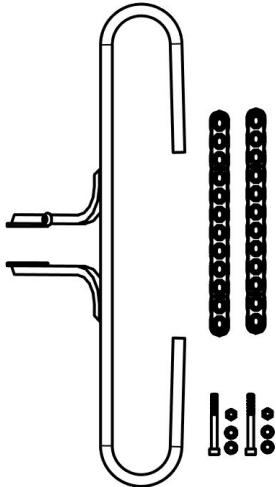

- 1) Tire Baskets
- 2) VelociRAX Straps
- 3) Assembly hardware
 - a. 3" (75 mm) hex bolts
 - b. hex bolt washers
 - c. hex bolt nylock nuts

(Quantities depend on model ordered)

Box 3. Hinge Assembly and Vertical Post

- 1) Hinge Assembly
- 2) Vertical post
- 3) 1/2 inch keyed hitch lock
- 4) Assembly hardware
 - a. 3.5" (89 mm) hinge bolt and nylock nut
 - b. (2) 3 inch washers
 - c. (2) washers

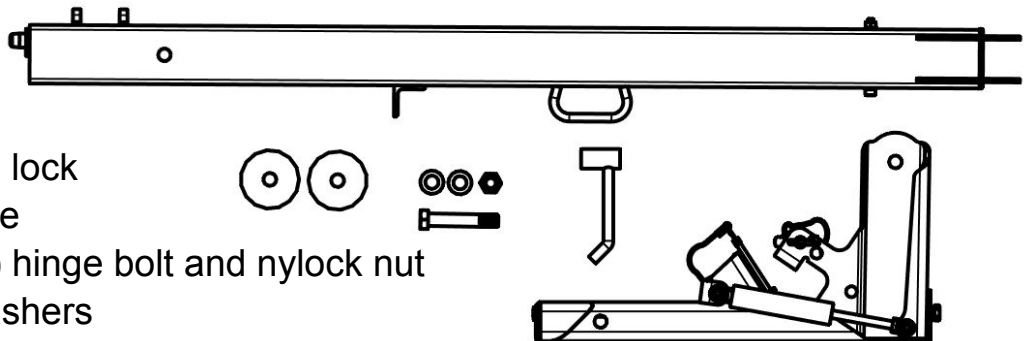

Latest instructions and videos: www.velocirax.com/pages/assembly



TOOLS REQUIRED FOR ASSEMBLY

- Wrench
or socket
- 2 X 24mm
 - 1 X 19mm
 - 1 X 18mm
 - 1 X 17mm
 - 1 X 16MM
 - 1 X 13mm

Alternate
• 2 X

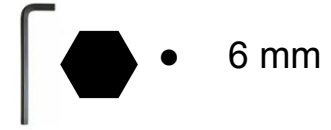

ASSEMBLY INSTRUCTIONS

Latest instructions and videos: www.velocirax.com/pages/assembly

1. Insert Hinge Assembly into Hitch and Lock in Place

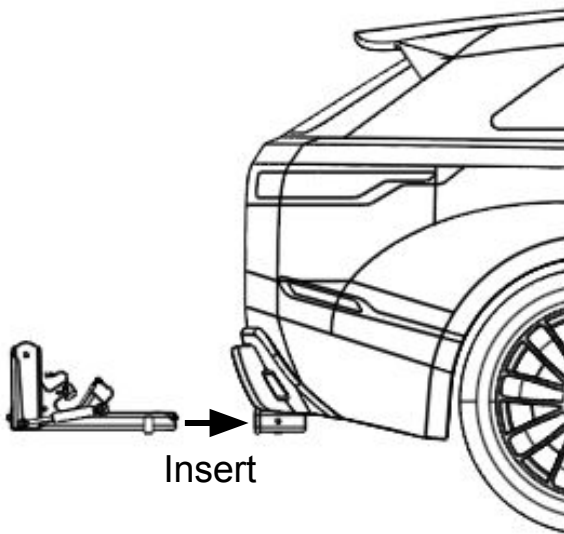

Unlock the pin with Key
Align hole & insert

Tighten  17 mm
(25 ft-lbs / 34Nm)

Move rack while tightening

Bolt eliminates motion between receiver and rack

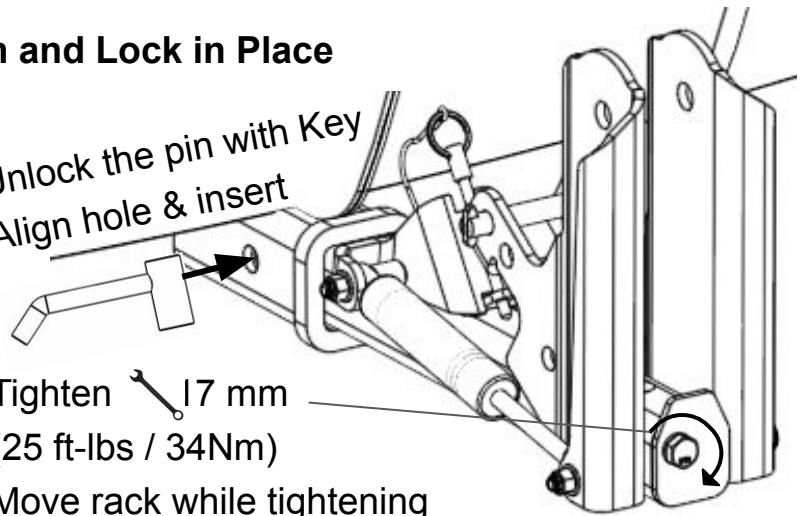

2. Install Vertical Post and Tighten in Place

Tip: See assembly video

www.velocirax.com/pages/assembly



3 inch washer

3.5 inch long hinge
bolt washers and nut

Tighten

 24mm
(45 ft-lbs / 61 Nm)

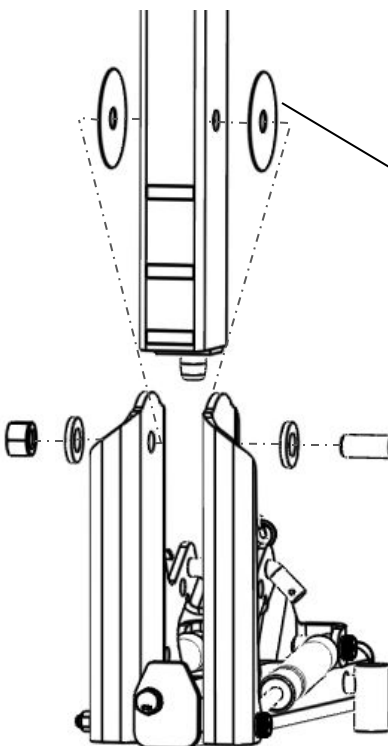

**Not tightening to 45 ft-lbs will
increase unwanted rack motion**

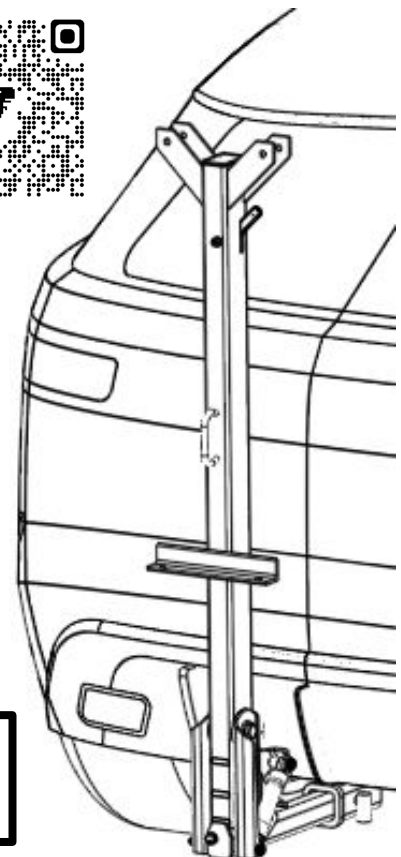

3. Install Top Crossbar and Tighten in Place

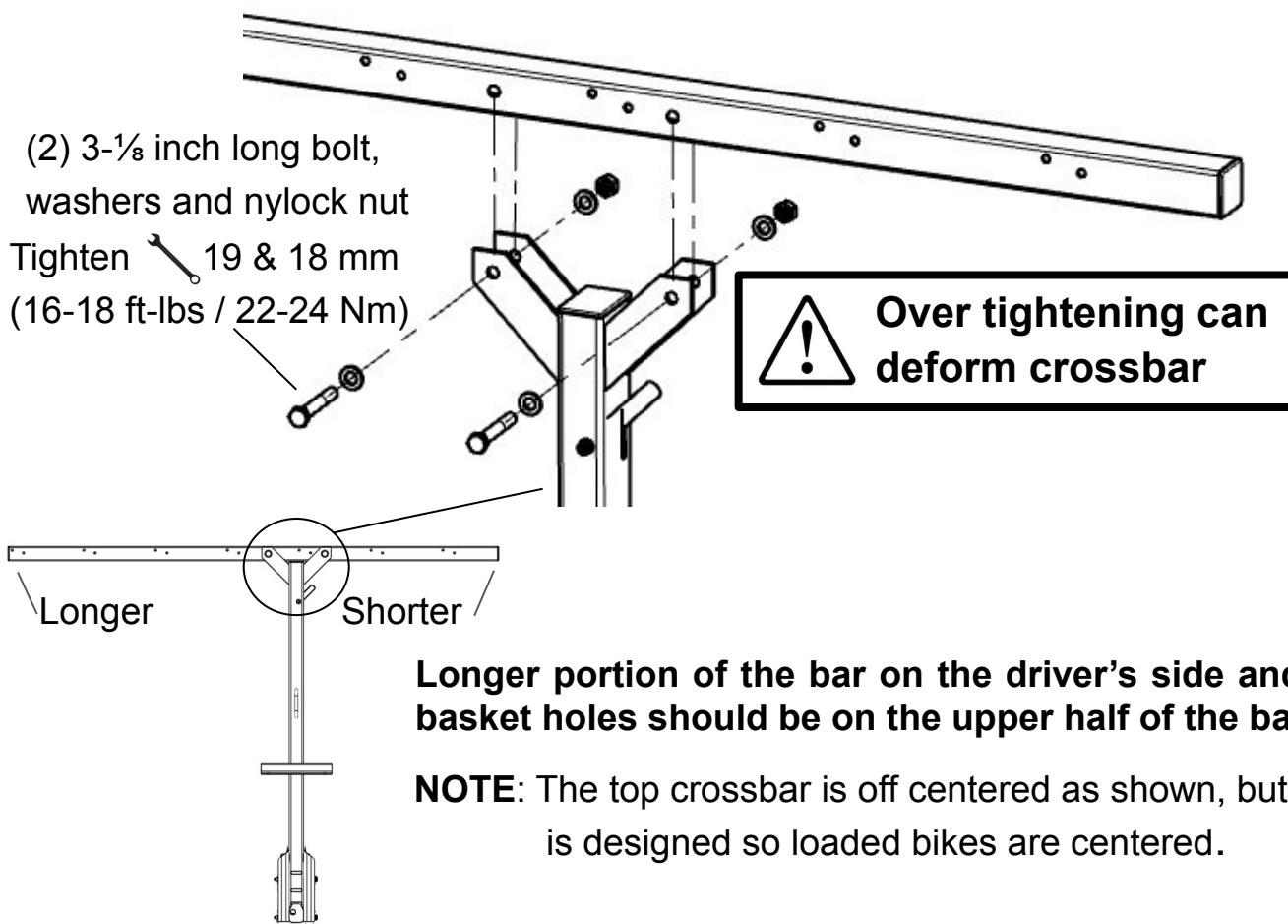

4. Install Tire Baskets and Tighten in Place

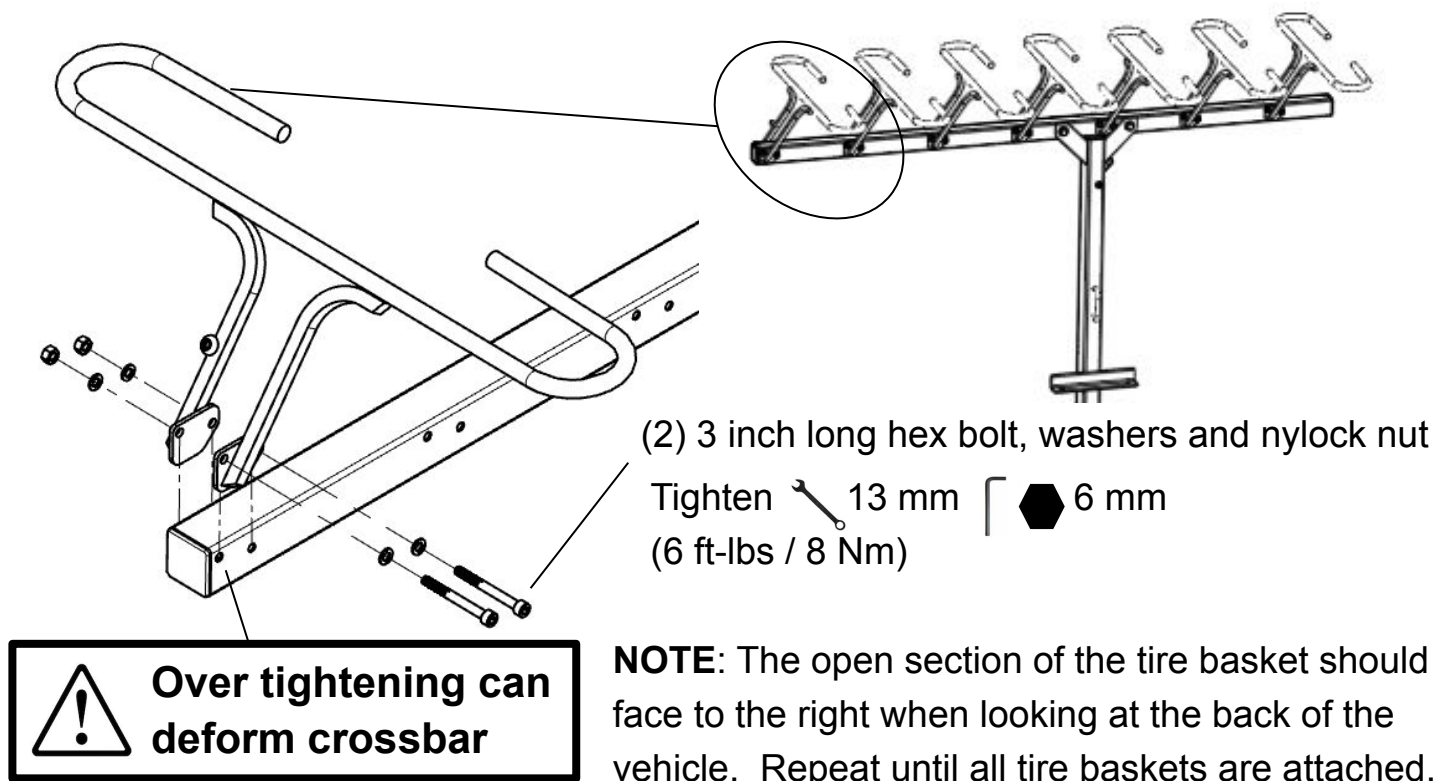

5. Install Bottom Crossbar and Tighten in Place

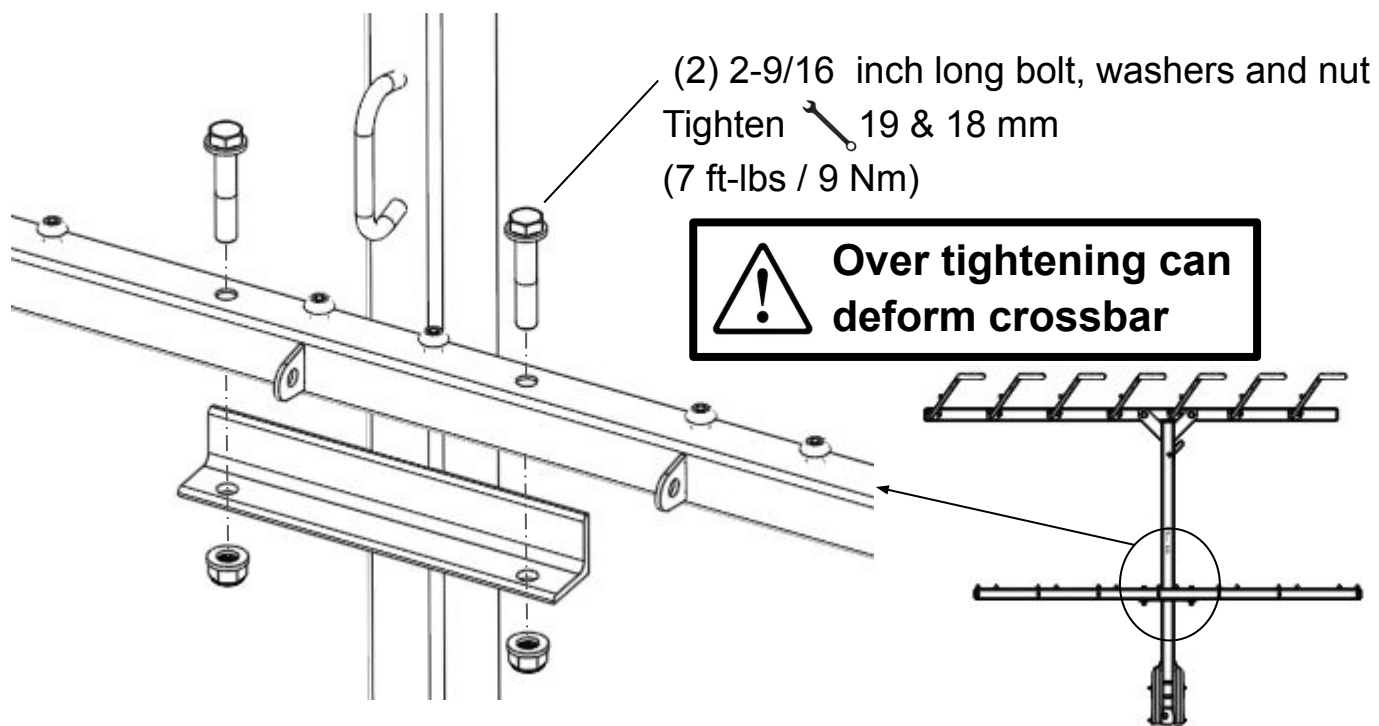

6. Stretch VelociRAX straps onto the Anchors

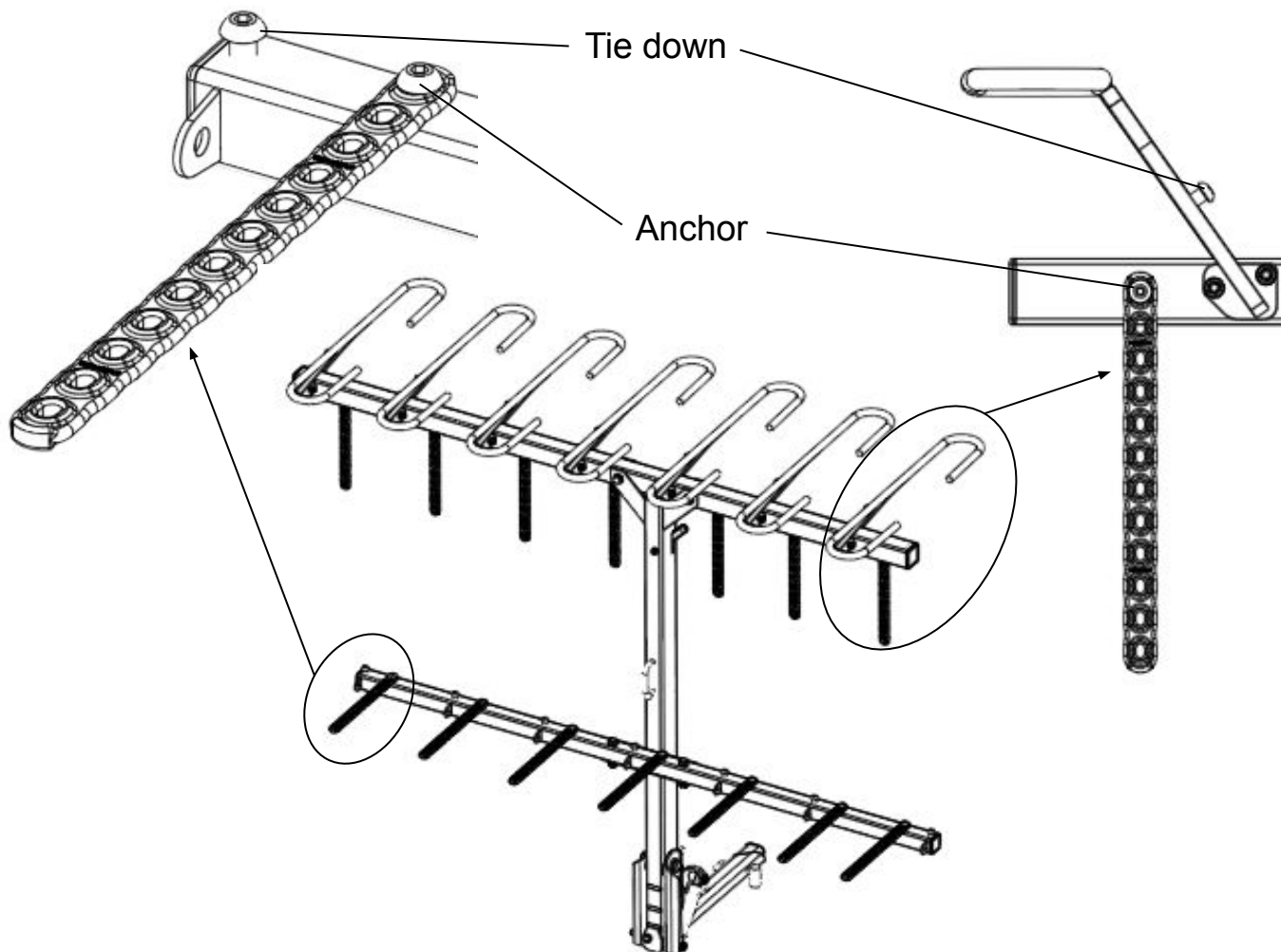

7. Activate Hydraulic Hinge Dampers

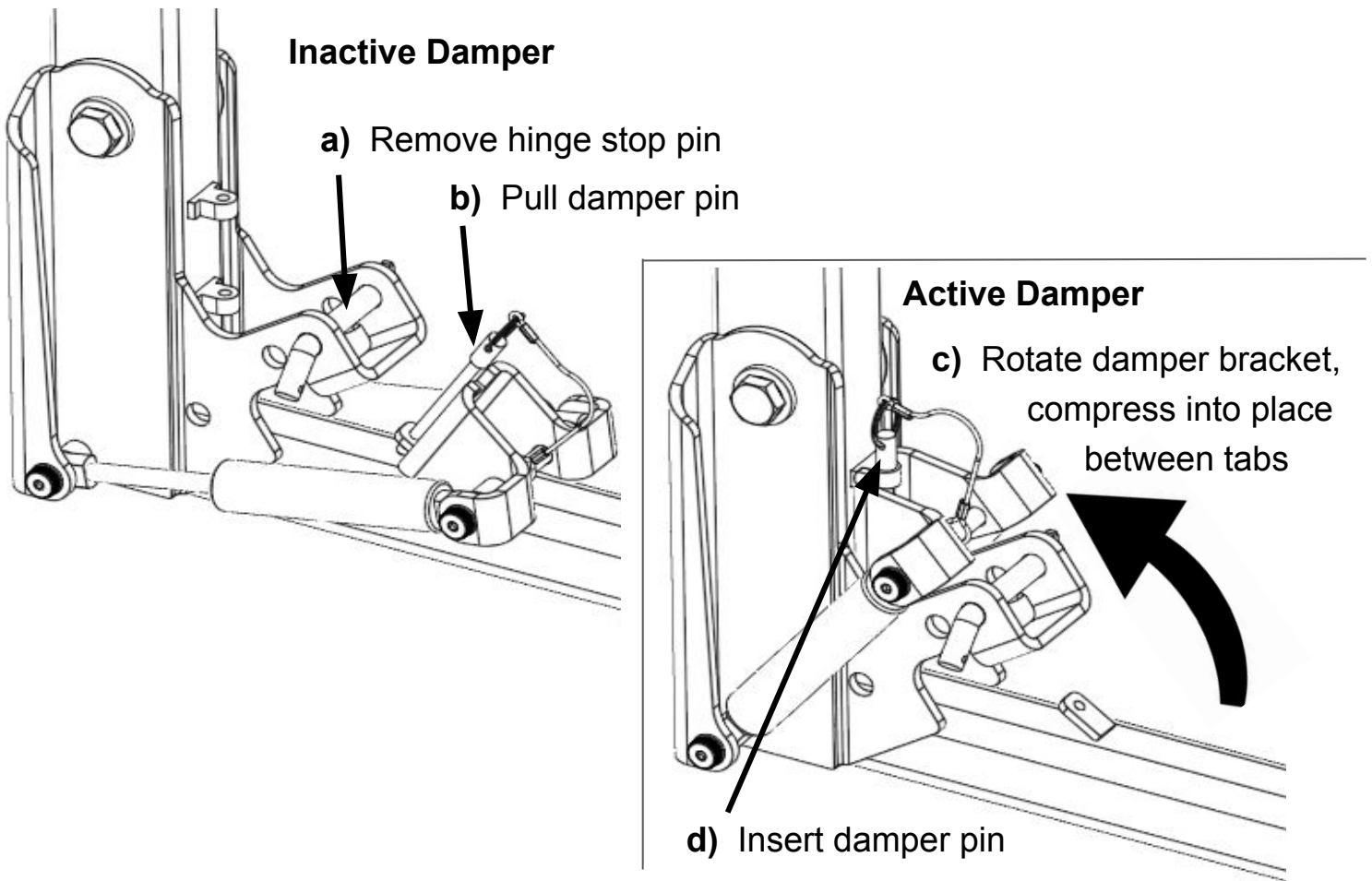

8. Insert the Stop Pin in Desired Position

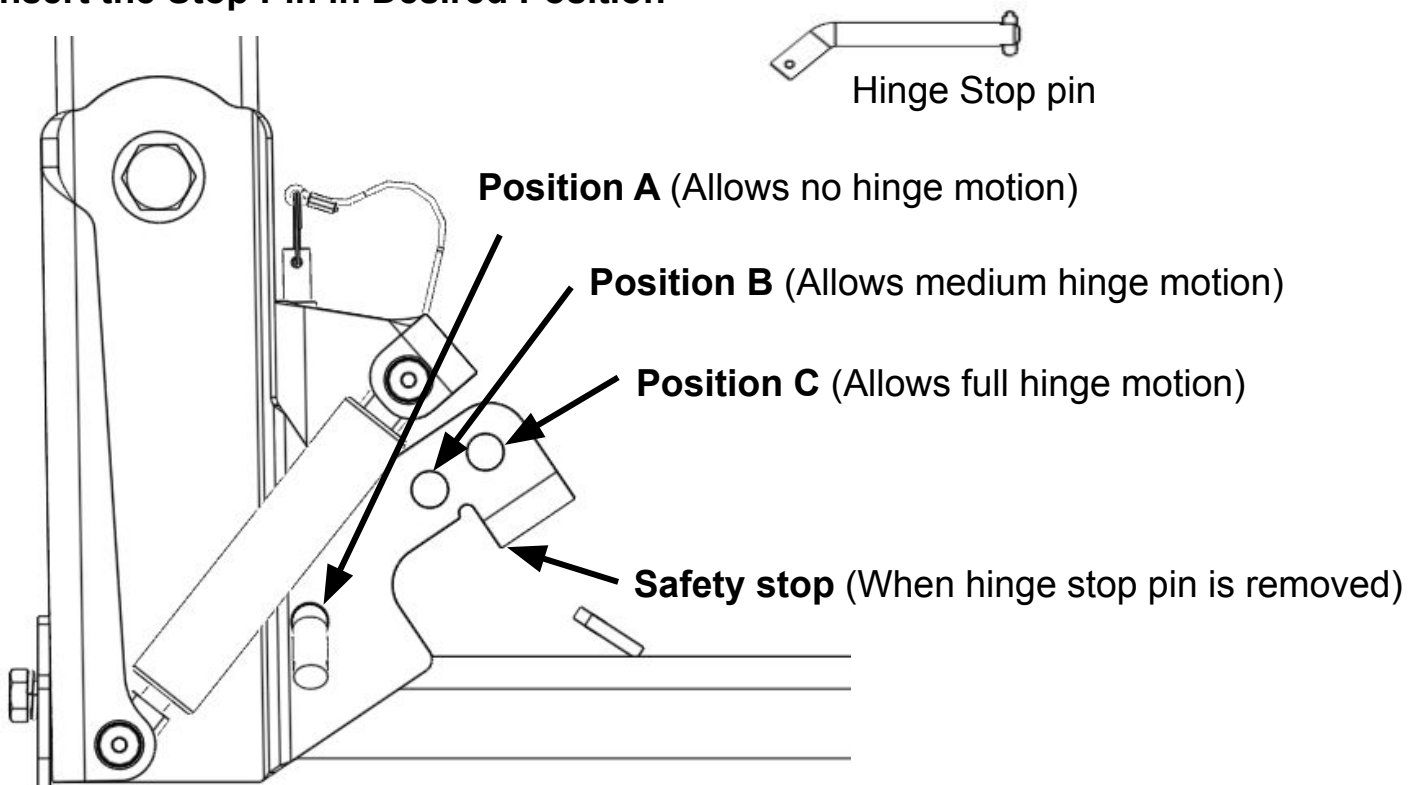

LOADING BIKES FOR TRANSPORT

1. Hinge Rack to Loading Position

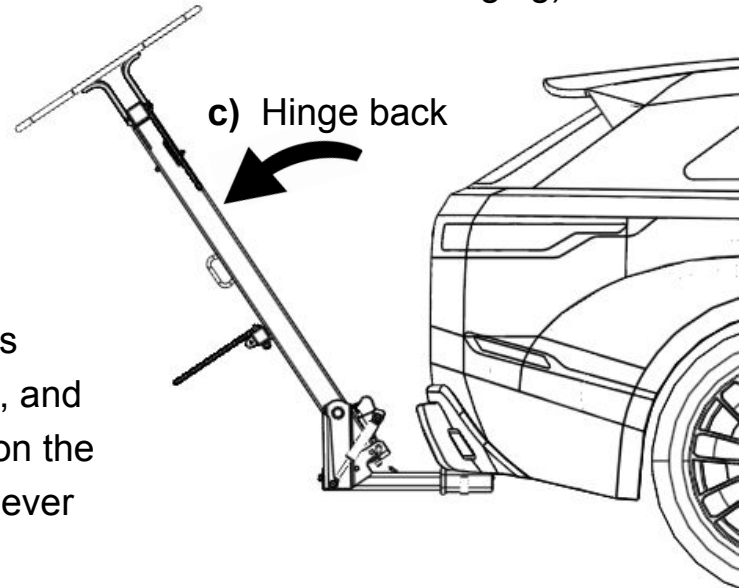
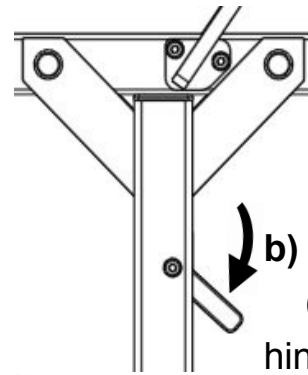
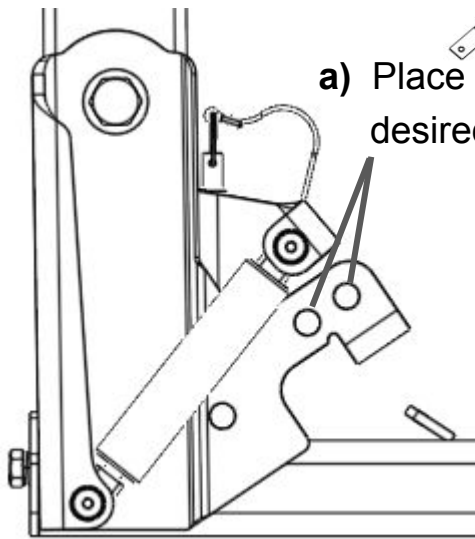

NOTE: Hinging is not required but eases loading, gives access for strapping tires, and allows rear lift gate access. A quick pull on the top bar toward the vehicle will allow the lever to release easily when lowering bikes.

2. Load Bikes

- a) Place front tires in tire baskets

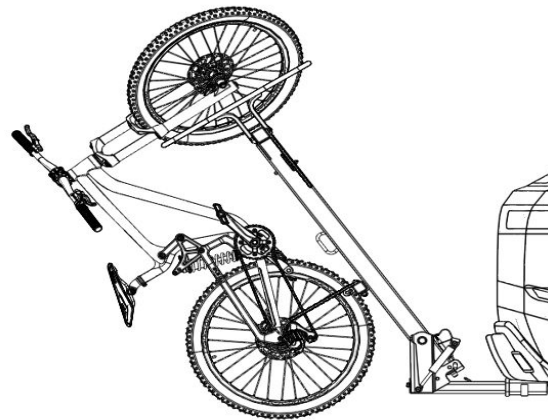
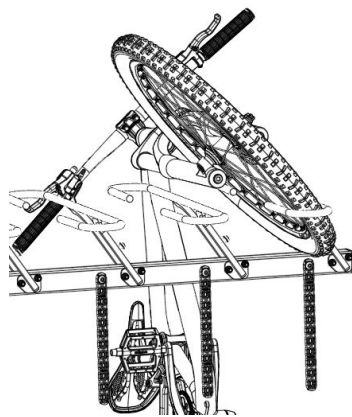

Loading Tips:

Generally VelociRAX loading is dependent on bike geometry. Load the rack left to right starting with DH -> Enduro -> All mountain-> XC. If bike geometries are the same, load the rack, largest to smallest, left to right, based on wheelbase. If bikes touch, switch load order until clearance is found between all bikes. With many bike types available it's hard to prescribe the perfect loading order for all situations. It will take a few minutes the first time, but loading will go quick as you get the hang of it.

3. Secure All Tire Straps

- a) Route VelociRAX Straps through tire/wheel. Straps should be **stretched tight** to fully secure on the tie down. Both tires should always be secured.

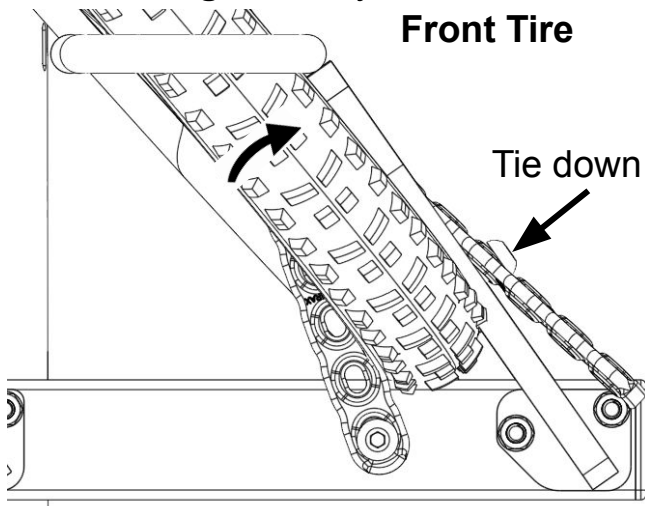

Back Tire

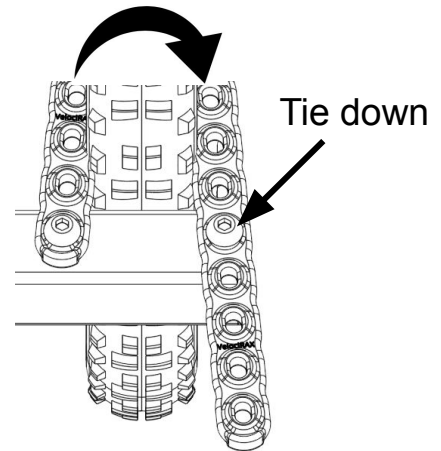

Tip: Have a second person double check all straps are secure

Lock Brake Levers with rubber bands

Place bands on front and rear bike brake levers to lock brakes and decrease motion between the rack and bikes. Especially use with e-bikes, RV/trailer setups, long road trips, or rough roads to minimize relative motion.

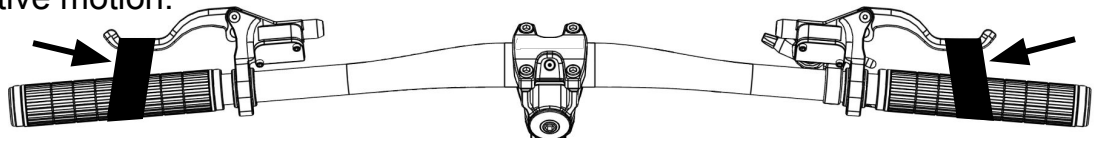

4. Raise Rack to Upright Position

- a) Push up on bike frames or tire baskets

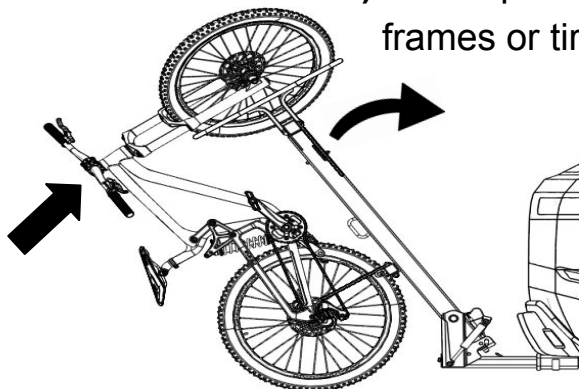

Tip: Two people pushing on bike frames makes this easier with a fully loaded rack.

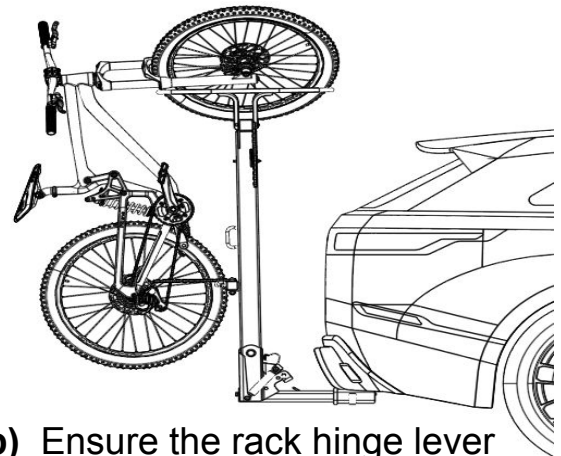

- b) Ensure the rack hinge lever is engaged
c) Move hinge stop pin to position A

DO NOT DRIVE VEHICLE WHILE THE RACK IS IN THE HINGED/LOADING POSITION

GARAGE Use FIRST TIME SETUP

1. Assembly Garage Bracket

(2) 3.5 inch hook washers and nuts

Install hooks into holes based on the rack size

Tighten  16mm
(16 ft-lbs / 21 Nm)

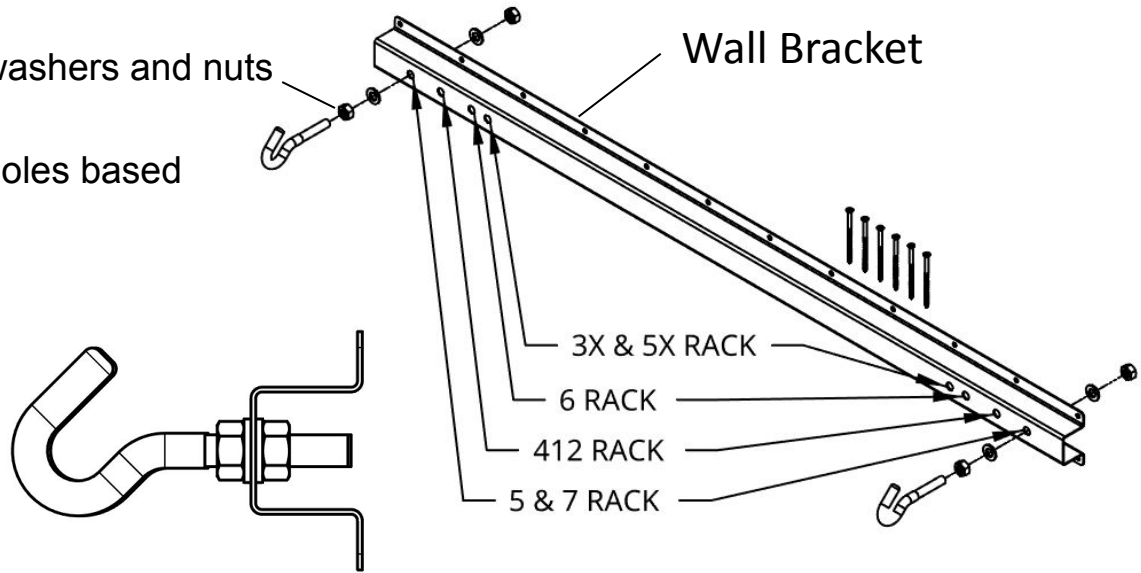

2. Secure Garage Bracket to Wall

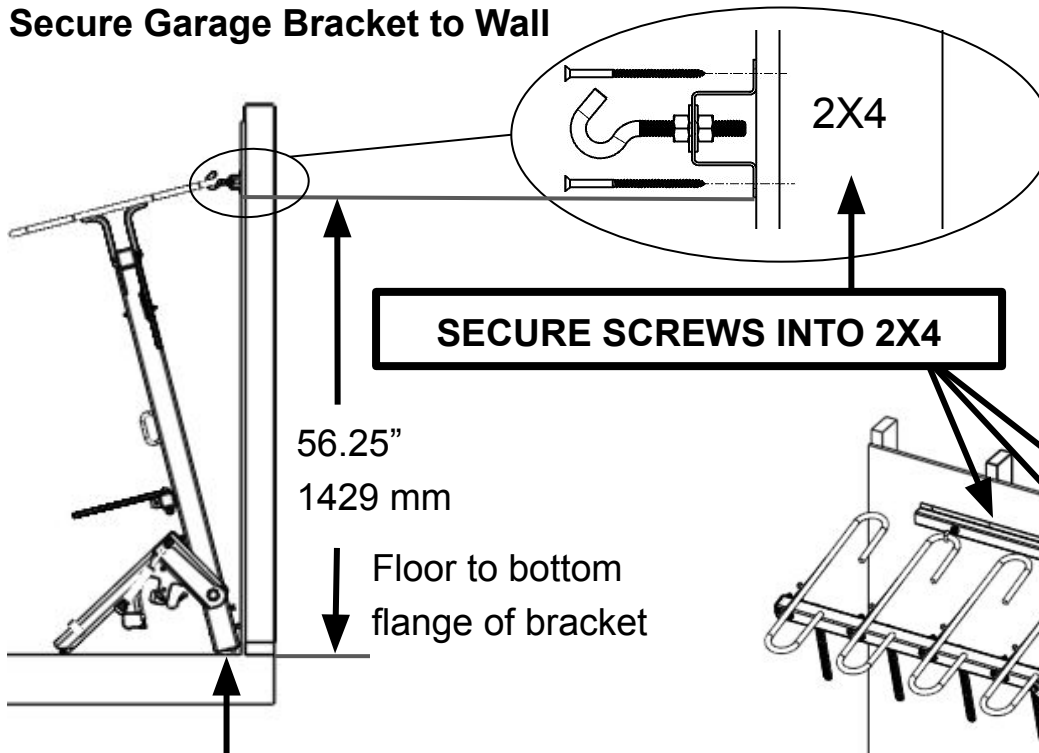

Tip: Bracket height is the same for both the solo mounting and standard mounting (as seen on the next page.)

Tip: To make sure long wheelbase bike's don't rest (back tire) on the floor raise the wall bracket 1" for every inch the wheelbase (axel to axel) is longer than 46". Place a block under the post equal to the height raised so the rack is fully supported on the wood block/floor.

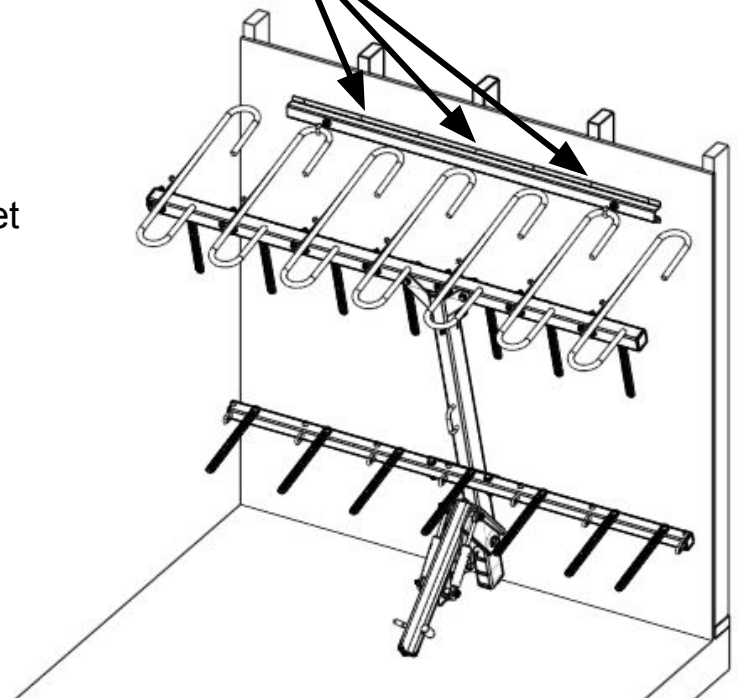

GARAGE MODE COMPARISON

Solo Mode

Easier setup,
Harder Bike Roll in/out

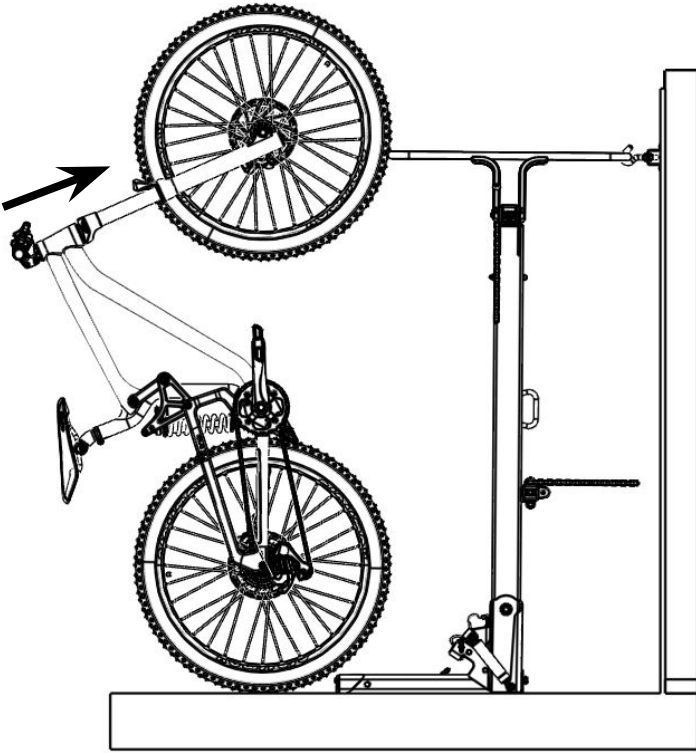

Standard Mode

Slightly Harder setup,
Easier Bike Roll in/out

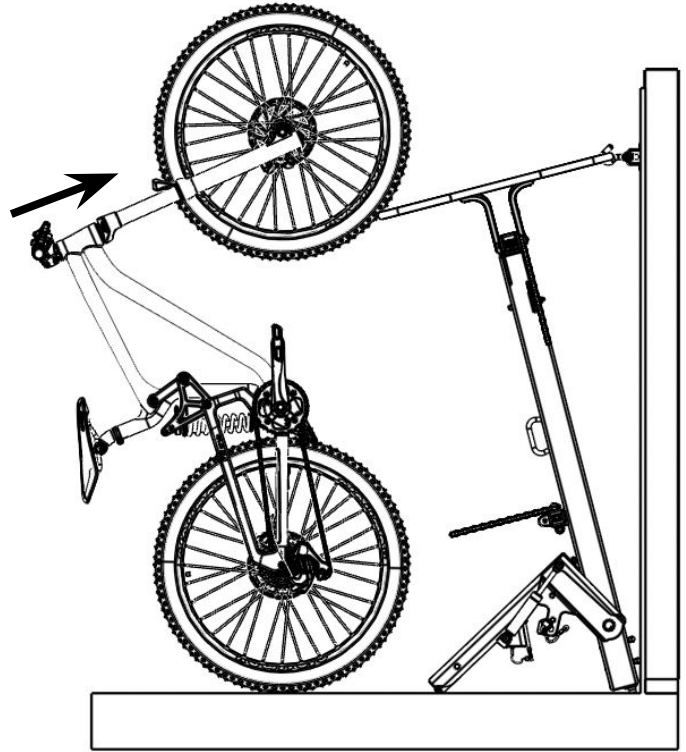

SOLO GARAGE MODE - AFTER USE ON VEHICLE

1. Remove Hitch Pin, Loosen Anti-rattle, and Hook on Garage Mount

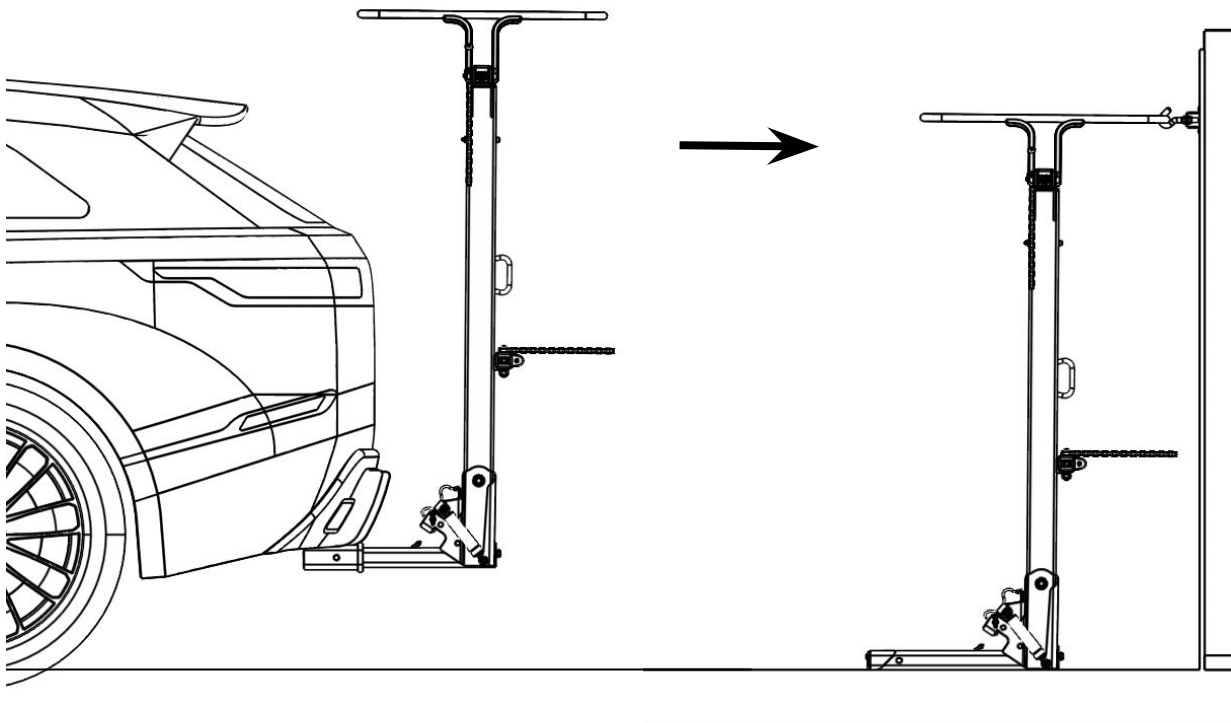

STANDARD GARAGE MODE - AFTER USE ON VEHICLE

1. Remove Hitch Pin and Loosen Anti-rattle

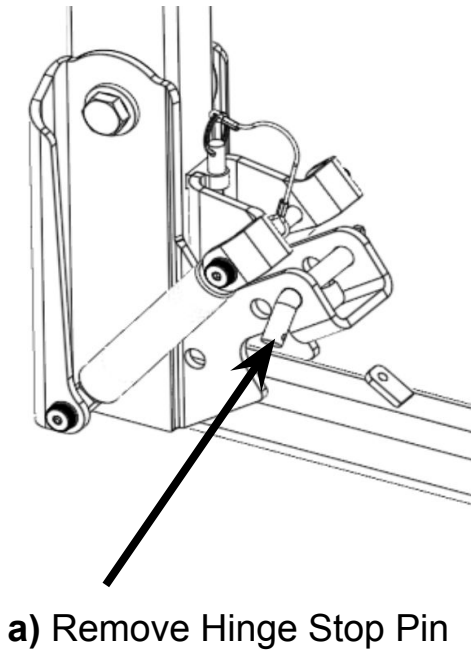

b) Hinge rack back
NOTE: Rack release pin stops rack
c) Pull Damper Pin

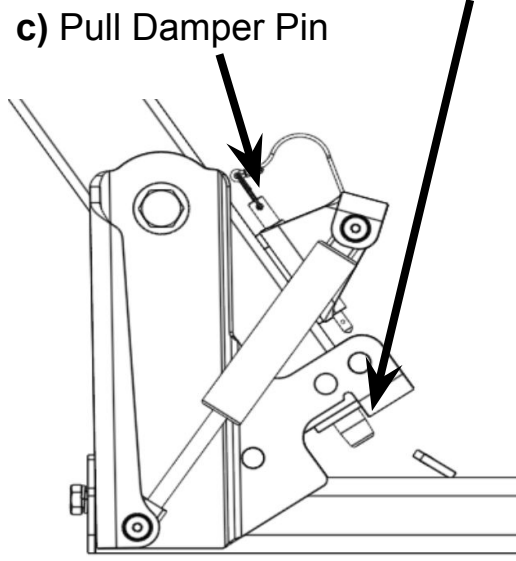

d) Roll Damper plate to hitch bar

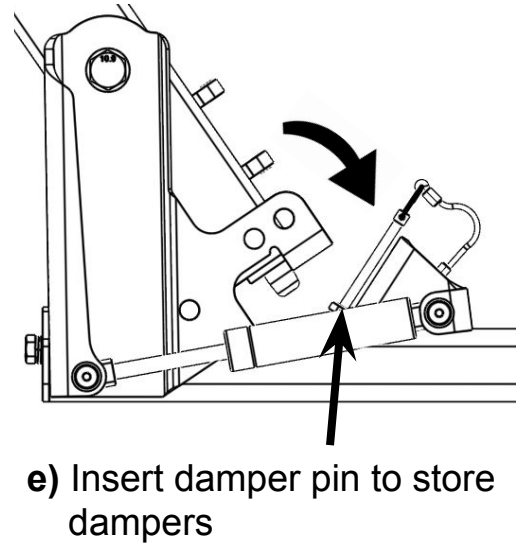

2. Remove Rack From Vehicle

a) Lower rack

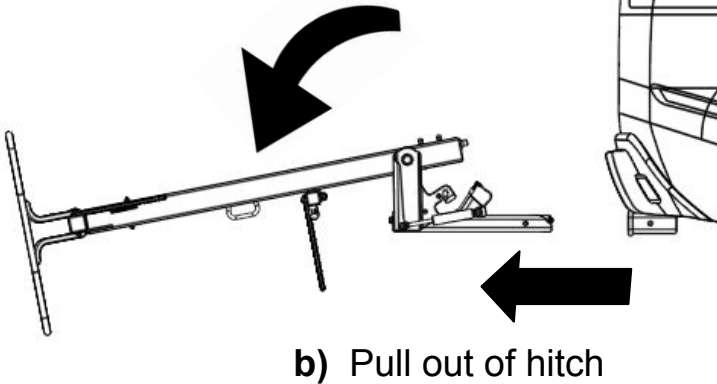

TIP: 2 person carry

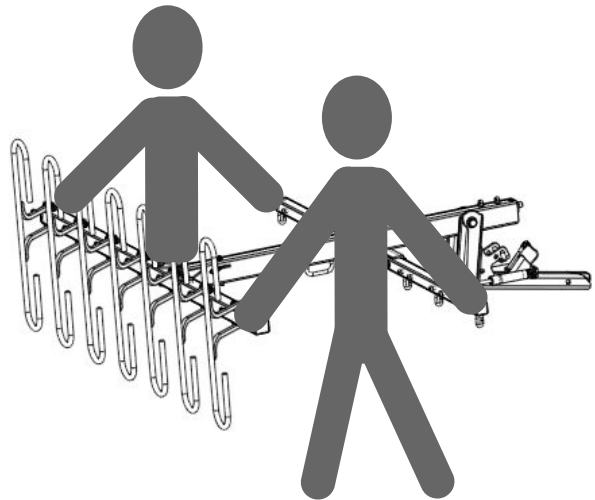

3. Rotate Hitch and Hook into Garage Bracket and Store Bikes

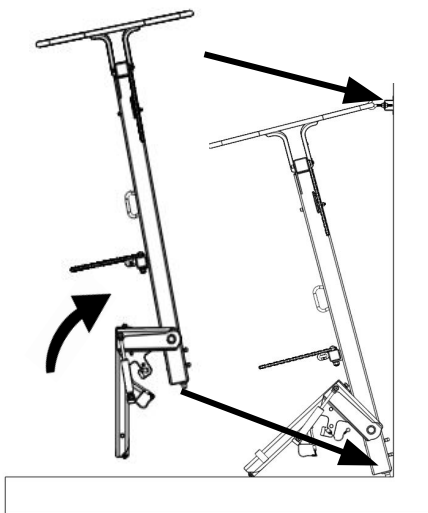

a) Roll bike into tire basket

Tip: For extra long bikes raise the garage bracket and place a wood block under the post as the rack and bike weight is transferred to the floor via the post.

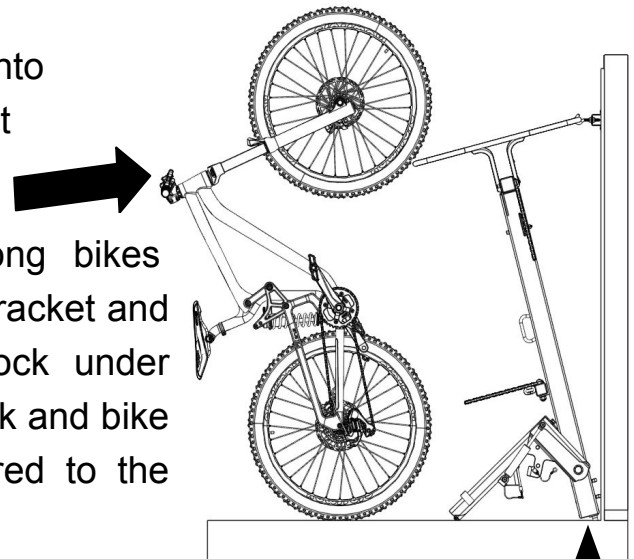

Release lever and Pin

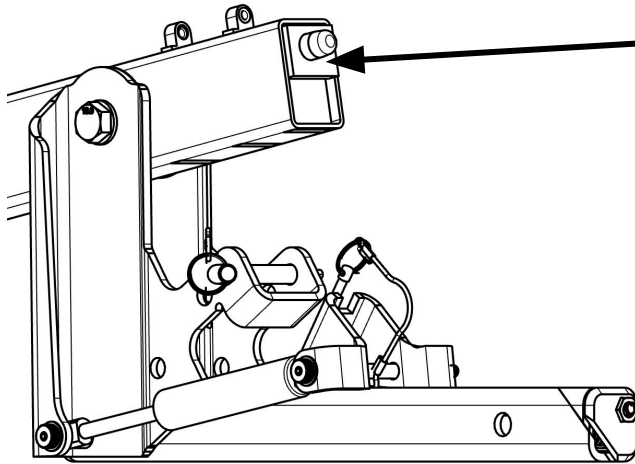

Wipe/clean any dirt/grime off the exposed pin. Use compressed air to make sure any debris around the pin is removed. Retract the pin and apply **graphite** (non liquid lubrication only) to pin and into gap around pin to keep the release lever and pin moving smoothly.



Squeak Prevention

If the above step doesn't increase performance and stop any squeaks you can wipe graphite, or add chain lube, or grease to top of bar to prevent hinging squeaks (between the pin and bar)

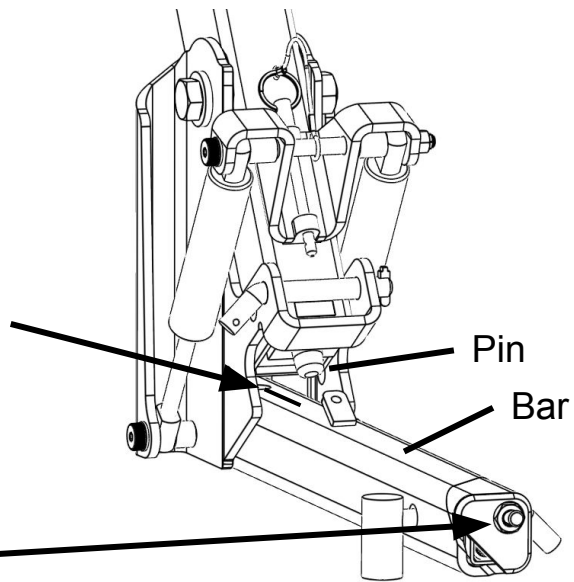

Anti-seize



Add anti-seize to the anti-rattle bolt to ensure the best long term operation of the anti-rattle mechanism.

TIPS

Bike Loading

Generally VelociRAX loading is dependent on bike geometry. Load the rack left to right starting with DH -> Enduro -> All mountain-> XC. If bike geometries are the same, load the rack, largest to smallest, left to right, based on wheelbase. If bikes touch, switch load order until clearance is found between all bikes. With many bike types available it's hard to prescribe the perfect loading order for all situations. It will take a few minutes the first time, but loading will go quick as you get the hang of it.

Lock Brakes with provided Rubber bands

Some natural motion will be seen in loaded bikes while transporting. This motion is allowed by small rotations back and forth in the axles, shocks, and tire pressure. To reduce this motion (especially with e-bikes, RV/trailer setups, long road trips, or rough roads) use rubber bands or bike tubes cut in ~1 inch sections placed on both brake levers to lock the brakes and minimize motion between rack and bikes.

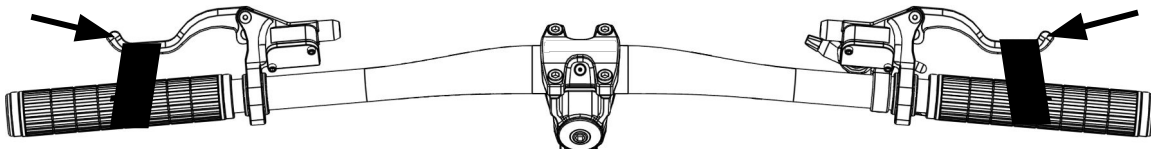

Anti-Rattle Bolt Tightening

Tighten anti-rattle bolt while slightly shaking rack. As it tightens movement will stop and the bolt will get tight. Add ¼ turn to fully lock anti-rattle.

Swing Aways can add unwanted vibration/motion; use at your own risk.

Hitch Lock

Add graphite to the keyhole and moving parts in the hitch lock at least yearly for best long term operation. Test to ensure the assembly is fully locked before each use.

Large Pedals

Occasionally wind can rotate large pedals, if this causes concern it can be helpful to hook the pedal to the lower cross bar with a bungee ball strap to prevent the pedal from rotating.

Lever Release to Lower Bikes

When standing between the vehicle and rack, a quick pull on the top bar toward the vehicle will allow the lever to release easily when lowering bikes.



Congratulations on your VelociRAX purchase! It will take you and your bikes to epic trails for years to come.

For support contact us at: Support@velocirax.com

For the latest version of these instructions, along with helpful instructional videos, please go to:

<https://www.velocirax.com/pages/assembly>

WARRANTY INFORMATION

2 Year Limited Warranty for defects in materials and/or workmanship for the original retail purchaser. This warranty does not cover normal wear and tear, scratches, accidents, misuse, or overloading.

PRODUCT REGISTRATION

Register your product for support and warranty coverage at:

<https://www.velocirax.com/pages/warranty-registration>

CONTACT INFORMATION

VELOCIRAX

Email: support@velocirax.com

Web address: www.VelociRAX.com

Phone: 435.344.4446