

PURE SINE WAVE INVERTER USER MANUAL



PS1001-NP



PS1002-NP



PS1003-NP



PS1004-NP



PS1005-NP



PS1006-NP

⚠ IMPORTANT SAFETY INFORMATION. SAVE THESE INSTRUCTIONS.

TO REDUCE THE RISK OF INJURY, USER MUST READ AND UNDERSTAND THIS INSTRUCTIONAL MANUAL. THIS MANUAL CONTAINS IMPORTANT INFORMATION REGARDING THE OPERATION AND INSTALLATION OF PRODUCT. PLEASE RETAIN FOR FUTURE REFERENCE.

THANK YOU FOR YOUR PURCHASE!

UNPACKING & INSPECTION

Thoroughly inspect the products. The package should contain the following:

1. Inverter
2. 2 Ft. + (Red) and - (Black) DC Cable
3. Remote
4. 15 Ft. Cable
5. User Manual

Contact Our Customer Care Team

855-233-9199

support@gowiseusa.com

Live Chat at gowisepower.com

M-F 8:30am - 4:00pm MST



TABLE OF CONTENTS

Unpacking & Inspection.....	2
Introduction.....	4
Standard Features.....	4
Protection Features.....	5
Remote.....	6
Safety Instructions.....	7
General Safety Instructions.....	7
Battery Precautions.....	8
DC Connection Precautions	8
Personal Safety Precautions	8
General Overview.....	10
Display Overview.....	11
Installation.....	12
Preparing for Installation.....	12
Inverter Unit Location.....	13
Installation Guide.....	14
Installation Materials.....	15
Operation.....	16
Maintenance.....	17
Battery Maintenance.....	17
Inverter Maintenance.....	17
Troubleshooting.....	18
Specifications.....	20
Warranty.....	22

INTRODUCTION

GoWISE Power Pure Sine Wave Inverters provide the convenience of household type power to run a wide variety of appliances, with low THD <3%. GoWISE Power Inverters converts 12.5 VDC to 115 VAC household power.

- This unit uses the latest in soft start technology. The output voltage gradually increases to the normal value from low value after the inverter is turned on. It can reduce a transient large current attack and help to start the hard start load. Large power inductive loads, such as electrical motors or capacitive loads (large power SMPS), adopt soft start.
- LED indicators are used for power input type and service notification.
- During normal operation, display and gauges are blue and green.
- This innovative design takes the stress and mystery out of using an inverter for RV's, and specialty vehicles.
- Design includes 2x surge capability for demanding loads, convenient outlets and a USB charging port.

STANDARD FEATURES

- Dual color gauges for AC power output and battery DC input
- 5V/ 2.4A USB power port and convenient outlets
- Compact and lightweight design
- Soft start noise filtered technology with 2x surge capability
- On/Off remote with 15 foot cable included
- Built-in safety with overload, over temperature, short circuit and reverse polarity protection. Audible alarm and shut down for low and high DC voltage, overload and over temperature conditions.

INTRODUCTION

GoWISE Power Pure Sine Wave Inverters are protected by a variety of features including:

Reverse Polarity Protection

The fuses will burn out when the positive and negative cables are reverse connected to protect the inverter.

Low Battery Shutdown

When the inverter is in low voltage, an alarm will go off first and if the voltage continues to reduce, the LED will turn red and the inverter will shut down. If the voltage rises to 12V +/- 0.5V, the inverter will automatically restart and the LED will turn from blue to green.

Over Temperature Protection

The inverter will automatically protect itself when it reaches a high temperature. An alarm will go off first then the LED will be red. The inverter will shut down and auto-restart.

Overload Protection

The inverter will automatically protect itself when the load is too high. An alarm will go off first then the LED will be red. The inverter will automatically shut down. The inverter will need to be restarted manually.

Over Voltage Protection

The inverter will automatically protect itself when it is in high voltage. The LED will be red and the inverter will automatically shut down. When the voltage drops to 15.5V +/- 0.5V, the inverter will auto restart.

Output Short Circuit Protection

The inverter will automatically self protect the unit by shutting down in the event of a short circuit. It will auto restart after shutting down when the short circuit is removed.

INTRODUCTION

GoWISE Power Pure Sine Wave Inverter Remote



1. The Inverter Includes a remote, mounting screws, and 15 Ft. cable.
2. The remote is designed to be mounted on a dash or other flat surface.
3. The remote cable should be plugged into inverter and the remote before being mounted.

NOTE: The remote is optional and not required for inverter operation. There is an ON/OFF switch located on the inverter itself. When powering the inverter ON, a normal indicator will be a green LED light. If the inverter short circuits, the LED indicator will turn red.

SAFETY INSTRUCTIONS

GENERAL SAFETY INSTRUCTIONS

IMPORTANT: READ AND SAVE THESE INSTRUCTIONS!

This user manual contains important safety instructions for the GoWISE Power Pure Sine Wave Inverters that must be adhered to during installation, operation and troubleshooting. Read and save this user manual for future reference.

Read these instructions carefully and become visually familiar with the equipment before installation, operation, servicing, or maintenance. The following precautionary messages may appear throughout this manual or equipment to warn of potential hazards or to call attention to information that clarifies or simplifies a procedure.

Before installing and using your new inverter, read all appropriate sections of this guide and any cautionary markings on the inverter, batteries and on your appliances.

CAUTION!

- **DO NOT** expose this unit to rain or snow.
- Use of attachments not recommended or sold by GoWISE Power will void warranty and may result in the risk of fire, electrical shock or personal injury.
- To reduce the risk of electrical shock, remove connection to AC power and DC connections prior to maintenance or cleaning. **Turning off controls WILL NOT reduce this risk.**
- HELP - Someone should be within the range of your voice or close enough to come to your aid when working with a lead-acid battery.
- **DO NOT** operate the inverter if the carton or unit has significant damage from being dropped or crushed, received a direct hit of force or is otherwise damaged.
- **DO NOT** dismantle the inverter. Call the factory directly when service or repair is required. Incorrect assembly may result in risk of electrical shock or fire. No user serviceable parts.
- **As a precaution - Keep children away from the inverter and its components!** The same potentially hazardous or lethal AC power that is found in a normal household 115 AC power outlet can be found in the power inverter.

SAFETY INSTRUCTIONS

BATTERY PRECAUTIONS

To reduce risk of battery explosion, follow these instructions and those published by battery manufacturer and manufacturer of any unit you intend to use in vicinity of battery. Review cautionary marking on these products and on engine.

⚠ SPARK - Be very cautious about dropping metal objects such as screwdrivers and wrenches onto a battery. This could short-circuit the battery and immediately cause a spark that may result in a fire or explosion.

DC CONNECTION PRECAUTIONS

Connect and disconnect DC output connections only after setting all inverter switches to OFF and removing AC cords from electric power.

PERSONAL SAFETY PRECAUTIONS

- 1.** WORKING IN VICINITY OF A LEAD-ACID BATTERY IS DANGEROUS. BATTERIES GENERATE EXPLOSIVE GASES DURING NORMAL BATTERY OPERATION. FOR THIS REASON, IT IS OF UTMOST IMPORTANCE THAT EACH TIME BEFORE SERVICING THE UNIT IN THE VICINITY OF THE BATTERY, YOU READ THIS MANUAL AND FOLLOW THE INSTRUCTIONS EXACTLY.
- 2.** NEVER charge or invert power from a frozen battery.
- 3.** If necessary to remove a battery from a vehicle or RV, always remove grounded terminal from battery first. Make sure all accessories are off, as not to cause an arc.
- 4.** Be sure area around battery is well ventilated.
- 5.** Clean battery terminals. Be careful to keep corrosion from coming in contact with eyes.
- 6.** Study all battery manufacturer's specific precautions such as removing or not removing cell caps while charging and recommended rates of charge.

WEAR - Complete eye protection and protective clothing. Avoid touching eyes while working near battery(s).

NEVER - Smoke or allow a spark or flame within the vicinity of the battery work area.

REMOVE - All personal metal items such as rings, watches, bracelets, etc. when working near a battery. A battery can produce a short circuit current high enough to weld a ring or any other metal causing serious burns.

SAFETY INSTRUCTIONS

PERSONAL SAFETY PRECAUTIONS (cont.)

⚠ WARNING: Restrictions on Use - The Power Inverter shall not be used in connection with life support systems or other medical equipment devices.

DANGER

- **HIGH VOLTAGE**
AVOID SERIOUS INJURY OR DEATH FROM ELECTRICAL SHOCK.
BEFORE PERFORMING ANY ELECTRICAL WORK TURN OFF AC POWER SUPPLY.
- **EXPLOSION HAZARD**
AVOID SERIOUS INJURY OR DEATH.
MAKE CONNECTIONS IN AN ATMOSPHERE FREE OF EXPLOSIVE FUMES.
- **LOW VOLTAGE**
AVOID SERIOUS INJURY FROM ELECTRICAL BURNS AND SPARKS.
BEFORE PERFORMING ANY ELECTRICAL WORK DISCONNECT ANY DC POWER SUPPLY FROM UNIT

CAUTION

- **HOT SURFACES** – TO REDUCE RISK OF BURNS DO NOT TOUCH WHILE IN SERVICE.
- Polarity and wire color must be observed when making the installation connection to a 12 volt battery.

Red DC input bar = + (positive) red cable battery connection only.

Black DC input bar = - (negative) black cable battery connection only.

NOTE: REVERSE POLARITY CONNECTION WILL DAMAGE UNIT AND VOID WARRANTY.

**SAVE THESE
INSTRUCTIONS**

GENERAL OVERVIEW

PS1 001-NP

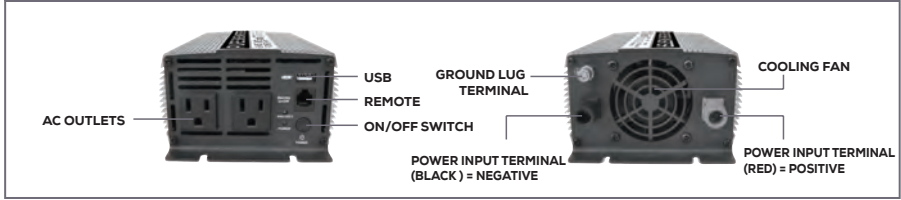

PS1 002-NP

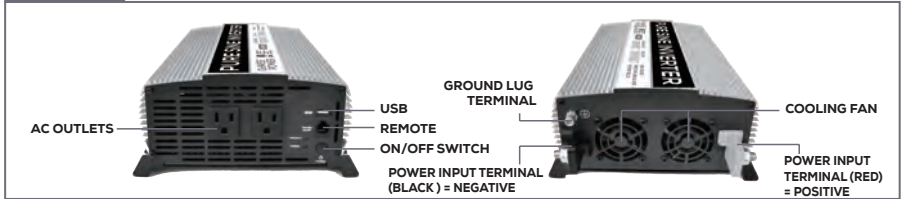

PS1 005-NP

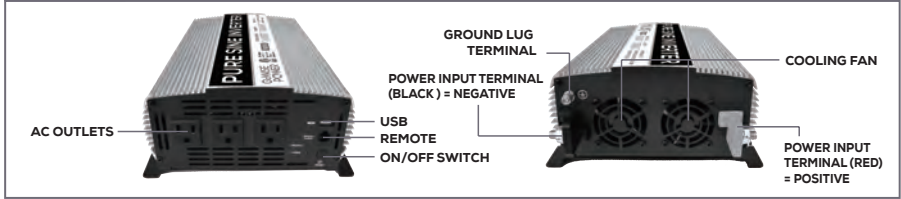

PS1 003-NP

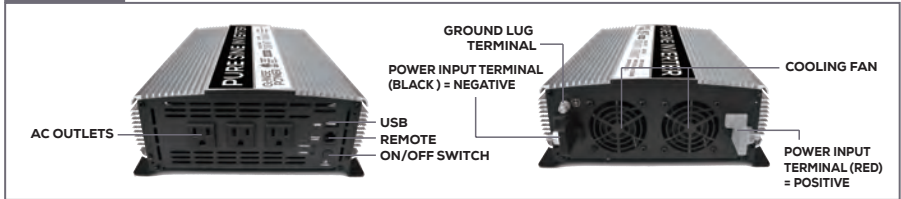

PS1 004-NP

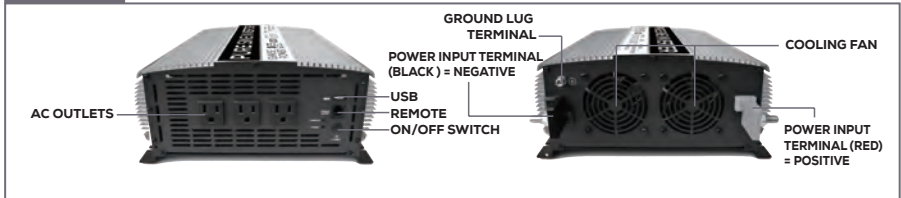

PS1 006-NP

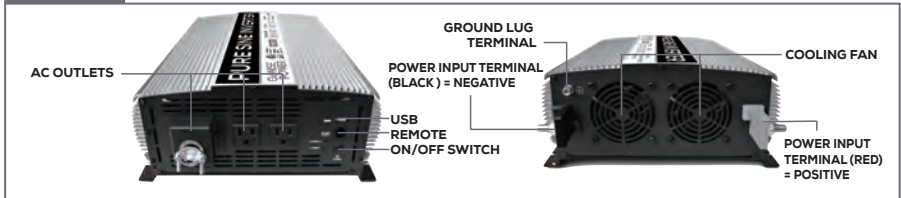

GENERAL OVERVIEW

DISPLAY OVERVIEW

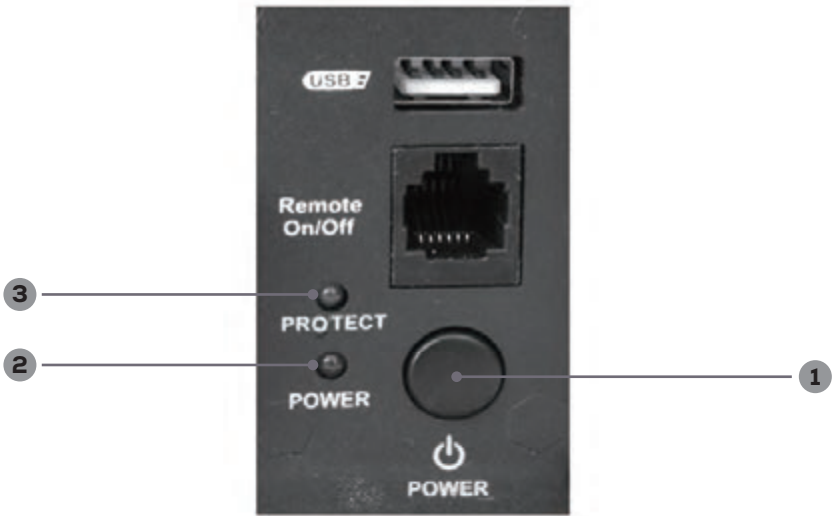

No.	Description	Details
1	Power Button	Turns on/off the inverter
2	Power Indicator	Green LED for 12.5V DC Input
3	Protect Indicator	Illuminates red when the Off inverter is in fault condition

System Status Fault Modes

All faults conditions are accompanied by a 2-second alarm (On/Off tone).

INSTALLATION

PREPARING FOR INSTALLATION

WARNING

- This device is not ignition protected, risk of fire or explosion.
- This equipment contains components that could produce arcs or sparks. To reduce the risk of fire or explosion, **DO NOT** install this equipment in compartments containing batteries, flammable materials or fumes, or in a location containing gasoline-powered machinery, or joints, fittings, or other connections between components of the fuel system.
- **DO NOT** mount the inverter above or below your batteries.
- **Electrical Shock and Fire Hazard**
We recommends all wiring be done by qualified personnel. Disconnect all AC and DC power sources to prevent accidental shock. Disable and secure all AC and DC disconnect devices and automatic generator starting devices. It is the installer's responsibility to ensure compliance with all the applicable installation codes and regulations
- **Installation Precaution**
The power inverter should be mounted on a flat horizontal surface or a vertical surface. In no case should the front or rear end caps be facing in an upward or downward position. This allows proper ventilation and product safety of the unit as intended by design.
- **Fire Hazard**
DO NOT cover or obstruct the ventilation openings. **DO NOT** install this equipment in a compartment with limited airflow. Overheating may result.
- Risk of fire or explosion.
- Low voltage - electrical burn and spark hazard.
- Disconnect battery power before servicing.
NOTE: This unit requires a large amperage draw from a DC battery when in inverter mode. Care must be taken during installation to provide properly sized cables from the battery to the inverter. Cable runs must be as short as possible and of the appropriate size and type. See the Installation section for more details.

Installation Recommendations and Requirements Include the Following:

The U.S. National Electrical Code (NEC)
RV Industry Association (RVIA)
The Canadian Electrical Code (CEC)
Canadian Standards Association (CSA)

INSTALLATION

INVERTER UNIT LOCATION

NOTE: Please re-read the PERSONAL SAFETY PRECAUTIONS section of this manual (pg. 8-9) prior to installation. This unit must be located in a cool, dry, well ventilated area, free from unsecured hardware. Temperature is also a serious consideration. **DO NOT** mount this unit in an engine compartment or areas where temperatures will exceed 104°F (40°C).

In addition, the following should be considered when choosing a location:

1. Locate inverter unit away from battery in a separate, well ventilated compartment.
2. Placement of the remote status panel - A length of communications cable is provided for remote-location of the status/on/off panel. Ensure the cable is long enough to reach the desired location (generally in proximity to the main panel board) and avoid any area where it can be damaged.
3. Ventilation - Allow at least 8 inches (20cm) of space at the DC end of the inverter for air flow, 1 inch (2.5cm) on each side, and 3 inches (7.5cm) at the AC end of the inverter. For cooling, the size of the space is not as important as the overall supply of air. The more clearance for ventilation around the unit, the better the performance. **DO NOT** allow the ventilation openings on the ends of the unit to become obstructed.

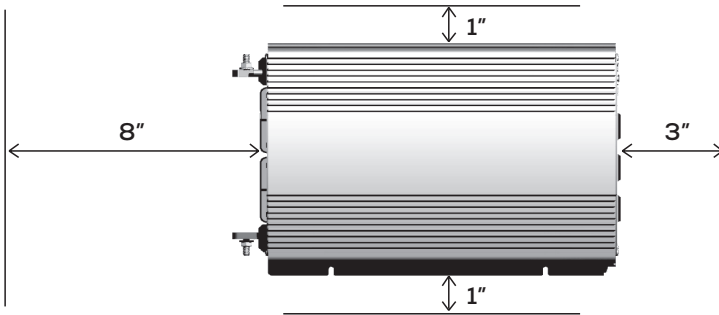

4. Cable Routing - Large DC cables and over current protection (fuses/circuit breakers) will be located in proximity to this unit. Choose a location AS CLOSE AS POSSIBLE to the DC battery bank serving the unit. This will provide optimum performance for the unit and keep cable sizes smaller. Location of the AC power is less critical than the DC supply.

MOUNTING - The weight of the inverter is very heavy. Be sure to place the inverter on a stable surface such as the floor, a table, or stand. Make sure the areas you place the inverter on can withstand the weight of the inverter. In addition, be sure to affix the product with the provided screws to keep the inverter from falling or moving.

INSTALLATION

INSTALLATION GUIDE

STOP: BEFORE INSTALLING YOUR INVERTER, READ AND FOLLOW THE CHECKLIST BELOW:

- Begin with the power switch and main shore/station power breaker in the OFF position. Ensure that all over current protection (e.g. fuses and/or circuit breakers) are ready for use, not blown or tripped.
- Use great care to ensure the polarity of the DC connections are correct or damage will result to your inverter.
- Verify all connections are tight, corrosion free and of good integrity.

DO NOT OPERATE THIS UNIT WITHOUT THE EARTH CONNECTION ATTACHED.

The earth conductor is permitted to be 1 common size smaller than the DC positive (+) conductor (Example: DC += 2 AWG, Earth = 4 AWG).

12 Volt DC Battery Source - Batteries can be a single battery or multiple batteries in parallel. Batteries connected in parallel boost amp hours while maintaining voltage. Tapping each battery as shown balances the load of the battery.

Parallel batteries illustrated:

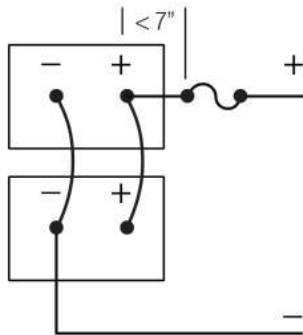

Parallel Batteries (12V) for a 12V Bank
(Increases the Amp/Hr Capacity)

⚠ CAUTION!

DO NOT connect the following in parallel:

- Batteries made by different manufacturers
- Different types of batteries
- Batteries that have different Ah ratings

Decreased battery life and improper charging will result.

INSTALLATION

INSTALLATION MATERIALS – CABLING

Use great care to ensure the polarity of the DC connections are correct or damage will result to your inverter.

1. DC Cables - The DC portion of the power Inverter requires a large amount of amperage in Inverter mode. Cable size and length is of extreme importance and should be well thought out and planned per this manual before beginning installation. Items to consider are as follows:

a. Cable Size - Size is based on amperage draw of the unit compared to the maximum amperage a cable can carry. We recommend NO MORE THAN a 10% drop in voltage from source (battery) to the GoWISE Power unit or a cable run not longer than 6 feet.

Recommended cable sizes:

Wattage	Cable Size	Cable Length	ANL Fuse
600W	6# pure copper	6 ft.	150A
1000W	4# pure copper	6 ft.	150A
1500W	2# pure copper	6 ft.	250A
2000W	0# pure copper	6 ft.	300A
3000W	2/0# pure copper	6 ft.	500A

b. Installing DC Safety ANL Fuse: Install fuse in positive (+) cable within 7" of battery. See above table for recommended fuse.

DO NOT ATTEMPT CABLE TERMINATION BY MEANS OTHER THAN PROPER CRIMPING, WITH A PROPERLY CALIBRATED TOOL. SOLDER AND AUTOMOTIVE REPAIR TYPE BATTERY TERMINALS ARE NOT ACCEPTABLE. USE OF ANY OF THESE TYPES OF TERMINATIONS WILL RESULT IN PREMATURE, UNWARRANTIED FAILURE OF THE GOWISE POWER UNIT.

2. AC Cables - AC Cables should be readily available in both 2 and 3 conductor. Size is based on the maximum amperage to be passed through the cable and unlike DC does not take into account the length of the cable run and voltage drop.

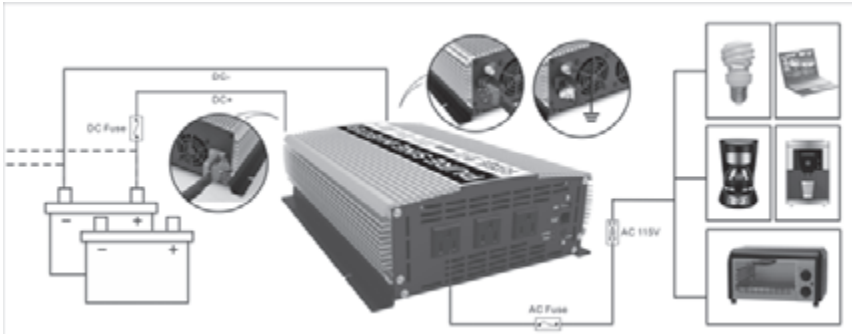

OPERATION

Inverter Power On and Off

The AC output can be turned on or off by pressing the POWER button on the display panel. With the remote feature, the inverter can be turned on or off remotely as well.

Operating the Inverter within the Load Range

Load Type Precautions

- **Resistive Loads** – Be careful with resistive loads that generate heat (toasters, electric stoves, etc.). Due to the high current drawn by these loads, a typical battery bank would be drained very quickly. Therefore, it would impractical to run the inverter with these types of loads for an extended period of time.
- **Motor Loads** – Use caution with the type of motor that you connect the inverter. Induction motors require a much higher startup current than their running current. Since motors vary in their characteristics, it is best to test the motor load on the inverter. If the motor does not start or loses power, the inverter should be turned off and the motor removed. If the motor startup current is too high, the inverter will turn itself off.

NOTE: Operation of this equipment in a residential area is likely to cause harmful interference in which case the user will be required to correct the interference at their own expense. If in a residential setting you are encountering interference with TV and Radio reception while NOT in inverter mode, then simply disconnect AC power from the power Inverter to confirm if this unit is causing the interference, if so explore the following options to minimize interference:

1. Make sure your AC connections include a proper ground connection
2. Reposition your receiving antenna
3. Purchase a separate AC line filter
4. Relocate the affected appliance so it is further separated from the power inverter



CAUTION: Check the power consumption of the unit to make sure that appliance is within the power range of the inverter to ensure that you **DO NOT overload the inverter**. Overloading the inverter will void the warranty.

This equipment has been designed to comply with:

- FCC Class A
- Underwriters Laboratories: Standard 458 Power Converter/Inverter Systems for Land Vehicles and Marine Crafts

MAINTENANCE

BATTERY MAINTENANCE

Periodically, check the batteries to make sure they are good condition. Check the terminals for corrosion and clean them with a wire brush if necessary. If the batteries are flooded lead-acid, check the electrolyte levels every month and top off with distilled water if needed. Finally, check the battery voltage in accordance with the manufacturer's specifications.

INVERTER MAINTENANCE

Little maintenance is needed to keep the power inverter running properly. To keep the unit running optimally, you should:

- Wipe the unit's exterior with a damp cloth to clean off dust buildup.
- Check that the DC cables are securely connected and the fasteners are tight.
- Clear the ventilation holes of dust buildup.

TROUBLESHOOTING

WARNING

ELECTRICAL SHOCK HAZARD

DO NOT disassemble the inverter. It does not contain any serviceable parts and attempting to service the unit could result in an electrical shock or burn.

Failure to follow these instructions can result in death or serious injury.

How to Troubleshoot Common Fault Conditions

This section details how to troubleshoot the power inverter. Follow the process below to narrow down the cause of unit fault conditions. Go through this process before contacting Customer Care Team.

- 1.** Check for any fault indicators. If a fault indicator is displayed, note it down before proceeding further.
- 2.** Note the conditions around the time the fault condition occurred. Record the following details:
 - Battery voltage at the time of failure
 - How many watts the inverter was putting out
 - Extreme environmental factors (ambient temperature, vibrations, moisture, etc.)
- 3.** If no fault indicators are displayed, check the installation:
 - Is inverter properly mounted and located in a clean, dry, adequately ventilated environment?
 - Is the battery in good condition?
 - Are the DC and AC cables properly sized, in good condition, and have clean and tight connections?
 - Have any fuses blown?
- 4.** When steps 1 through 3 have been completed, contact Customer Care Team for further troubleshooting. Be prepared to provide information surrounding the unit failure as well the unit model and serial number (the serial number is normally underneath the product).

TROUBLESHOOTING

Fault Message	Condition	Action
LOW DC ALARM	Battery voltage has fallen below 10.5 V +/- 0.5 V	<ul style="list-style-type: none"> • Check battery voltage and recharge if needed • Check for proper DC cable sizing • Check for loose connections and tighten if needed • Charge batteries to clear fault
LOW DC SHUTOFF	Battery voltage has fallen below 10.0 V +/- 0.5 V and inverter output is shutoff	<ul style="list-style-type: none"> • Check battery voltage and recharge if needed • Check for proper DC cable sizing • Check for loose connections and tighten if needed • Charge batteries to clear fault
HI DC SHUTOFF	Battery voltage is above 15-16.5 V and inverter output is shutoff	<ul style="list-style-type: none"> • Check for other DC inputs, such as an over voltage alternator, and disconnect if needed • Decrease input voltage to clear fault
HI TEMP SHUTOFF	Inverter internal temperature is above > 149°F (65°C) and inverter output is shutoff	<ul style="list-style-type: none"> • Reduce the loads connected to the unit AC output. • Check for proper ventilation to the unit and remove any obstructions • Check the ambient temperature and move the unit to a cooler location if possible • Push button twice to clear fault
OVERLOAD SHUTOFF	Inverter output is greater than 105% and is shutoff	<ul style="list-style-type: none"> • Reduce the loads connected unit AC output • Check for loads that have a high surge & remove if needed • Push button twice to clear fault

If the GoWISE Power Pure Sine Wave Inverter still malfunctions after all solutions have been exhausted, please contact our Customer Care Team at 855-233-9199.

SPECIFICATIONS

Description	Pure Sine Wave Inverter	600W	1000W	1500W	2000W	3000W
Input Characteristics	Input Over-Voltage Protection	15~16.5VDC				
	Input Under-Voltage Protection	9.5~10.5VDC				
	Voltage Range	11~15VDC				
	No Load Current	≤1A @12.5VDC				
Output Characteristics	Continuous Output Power	600W	1000W	1500W	2000W	3000W
	Surge Power	1200W	2000W	3000W	4000W	6000W
	Efficiency MAX.	≥90%				
	Output Waveform	Pure Sine Wave (THD<3% @Normal Load)				
	Output AC Voltage	AC 105-125V				
	Output Frequency Level	60 ± 1HZ				
Protection	Input Protection	Over/Under Voltage, Reverse Polarity (Internal Fuse)				
	AC Output Protection	Short-Circuit, Overload				
	Others	Over Temperature Protection				

WARRANTY

GoWISE Power warrants all products against defects in materials and workmanship for **one (1) year** effective from the date of purchase.

GoWISE Power will replace any products that are found to be defective due to manufacturer flaws based on eligibility. Refunds issued by GoWISE Power must be purchased directly from GoWISE Power and are only available to the original purchaser within the first 30 days. We do not issue refunds for items bought by thirdparty retailers.

This warranty extends only to personal use and does not extend to products that has been used for commercial, rental or any other use this product was not intended for. There are no warranties other than the warranties expressly set forth with each product.

This warranty is non-transferrable. GoWISE Power is not responsible in any way for any damages, losses, or inconveniences caused by equipment failure by user negligence, abuse, or use noncompliant with the user manual or any additional safety, use, or warnings included in the product packaging and manual.

This warranty only covers purchases within the 48 contiguous states of United States of America. For purchases made outside the 48 contiguous states, such as AK, HI, PR, or Canada, we will replace the unit under the one-year warranty upon receipt of a proven defect by video or picture. However, the replacement will only ship to a freight forwarder or address within the 48 contiguous United States. The consumer is responsible for arranging shipment outside of the 48 contiguous states.

GoWISE Power assumes no liability for damage caused using this product other than for its intended use or as instructed in the user manual. Some states do not allow this exclusion or limitation of incidental or consequential losses, so the foregoing disclaimer may not apply to you. This warranty gives you specific legal rights and you may also have other rights which may vary from state to state.

ALL EXPRESSED AND IMPLIED WARRANTIES INCLUDING THE WARRANTY OF MERCHANTABILITY, ARE LIMITED TO THE PERIOD OF THE LIMITED WARRANTY.

NOTE: General Warranty excludes refurbished / auction items.

WARRANTY

DEFECTIVE PRODUCTS & RETURNS

If your product is defective within the 1-year warranty period, please email our Customer Care Team at support@gowiseusa.com. To expedite your issue, please provide the 4 items below:

1. Copy of the invoice, order information, or gift receipt showing the date of purchase
2. Serial number, usually found on a sticker located on the bottom on back of the unit
3. Picture or video of the issue or defect that you are experiencing
4. Shipping address information

Authorized Retailers:

Amazon

GoWISE Power



www.gowisepower.com

855-233-9199

support@gowiseusa.com

Live Chat at gowisepower.com

M-F 8:30am - 4:00pm MST

- To ensure the correct use of this unit, read these instructions carefully and thoroughly.
- Please keep this manual for future reference.
- Thank you for purchasing this GoWISE Power Pure Sine Wave Inverter.