

1

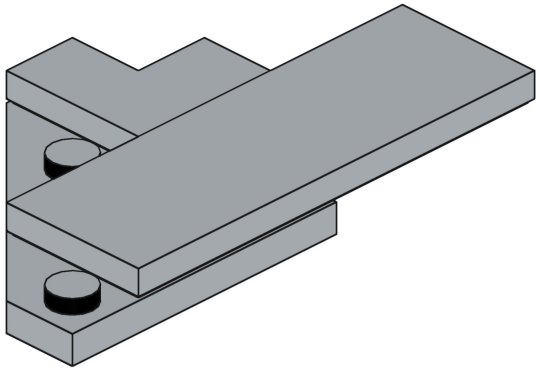

2

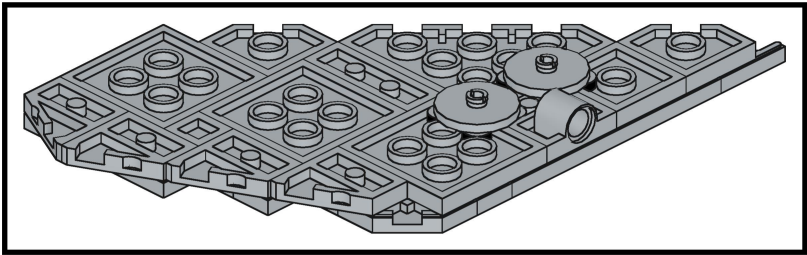
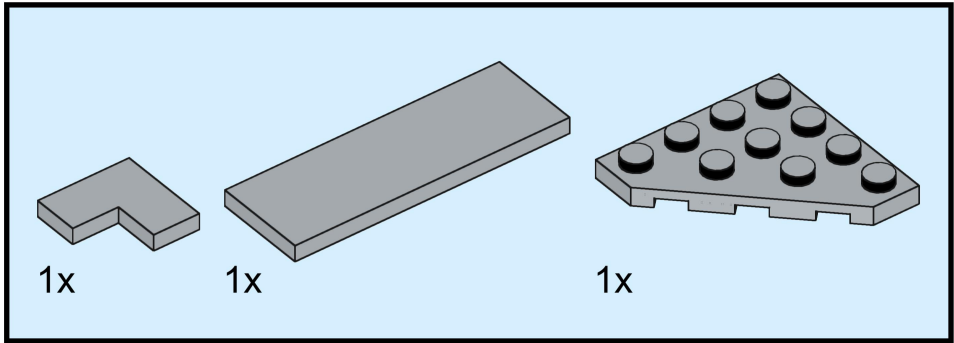
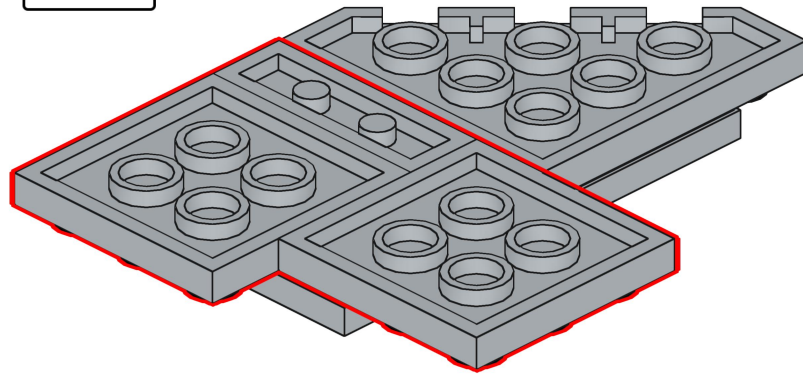
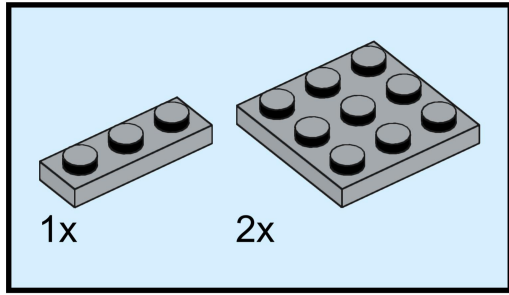

3

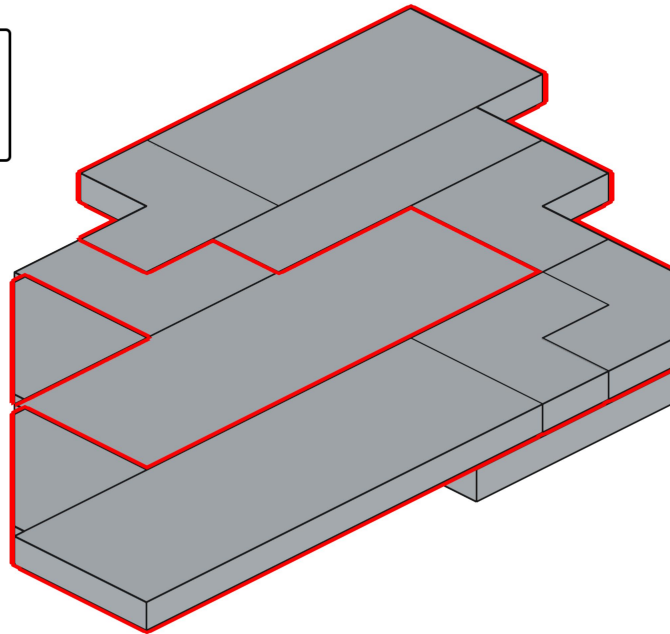
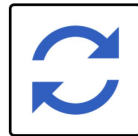
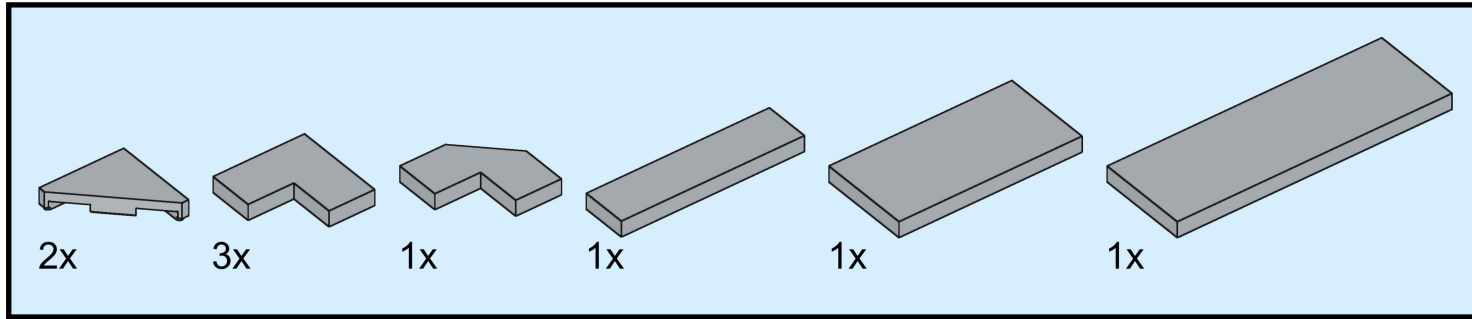

4

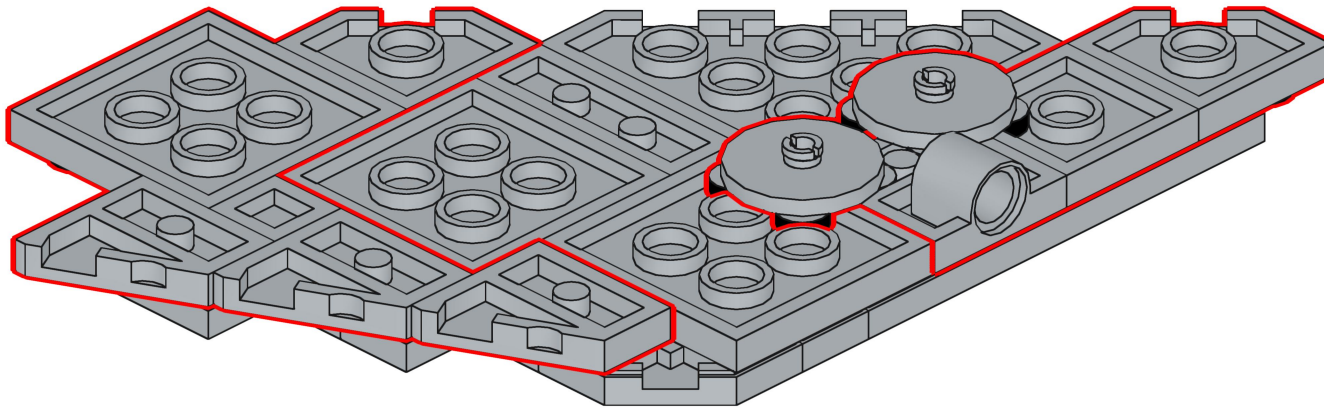
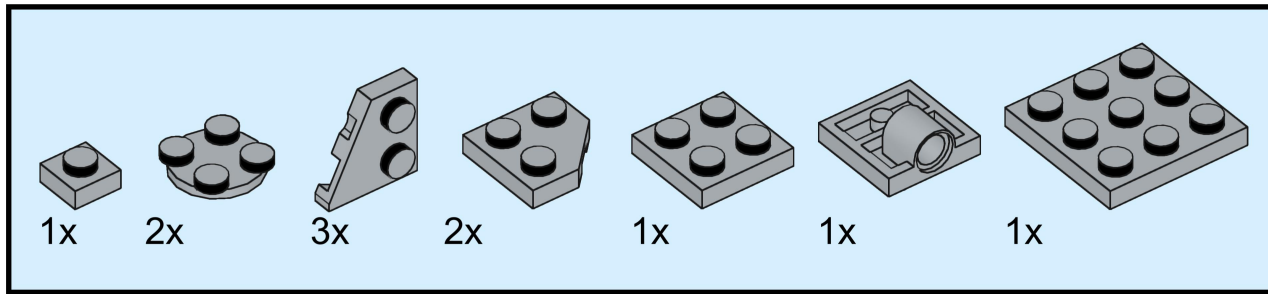

5

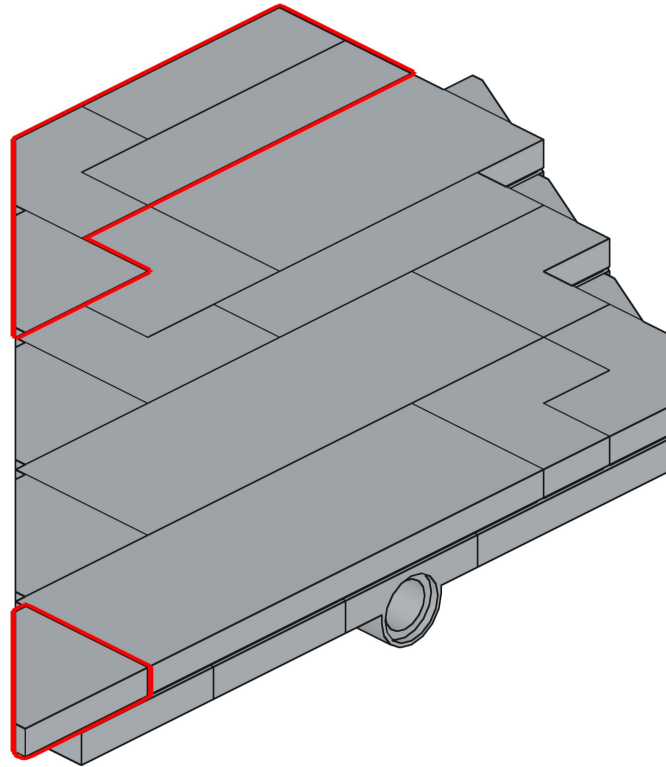
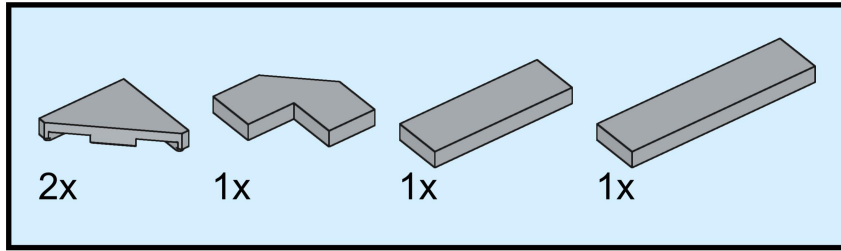

6

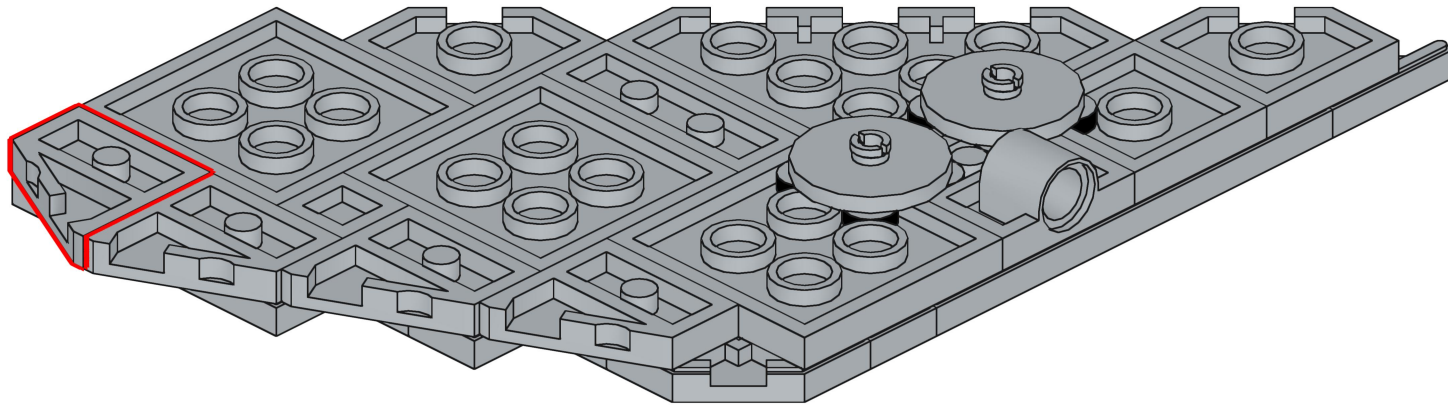
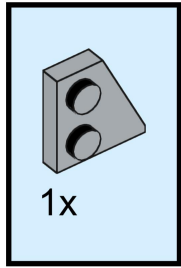

7

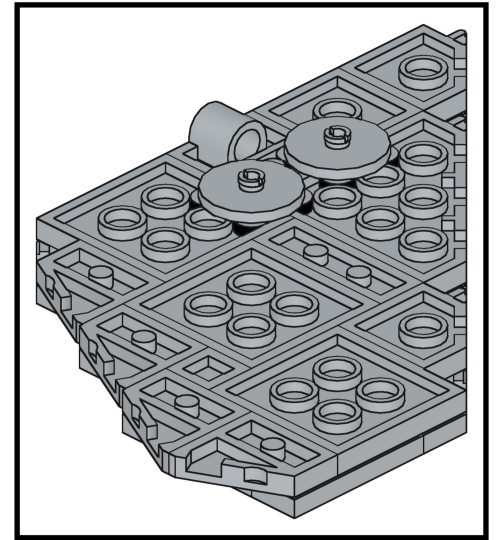
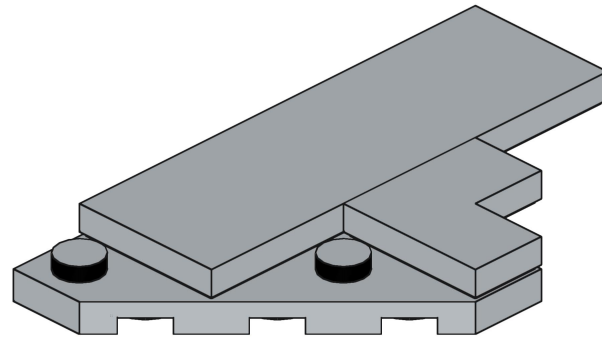
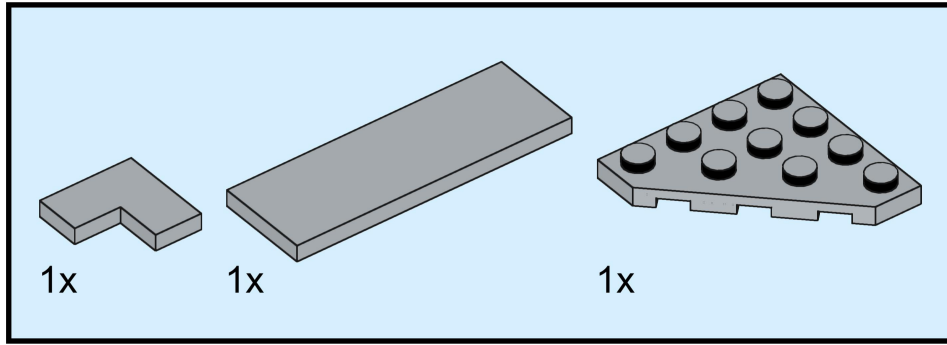

8

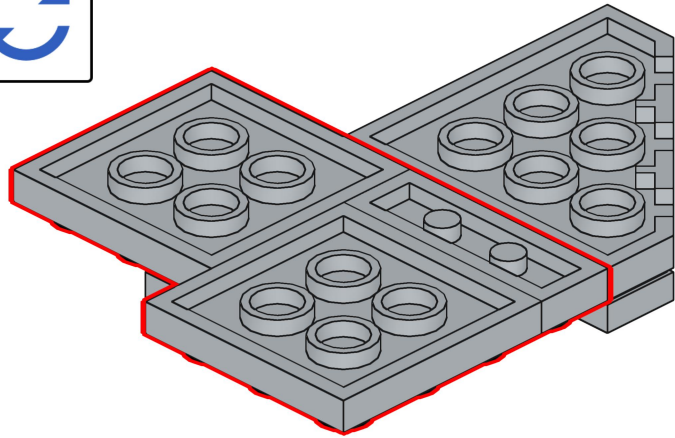
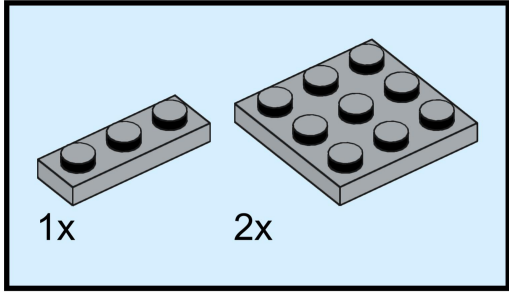

9

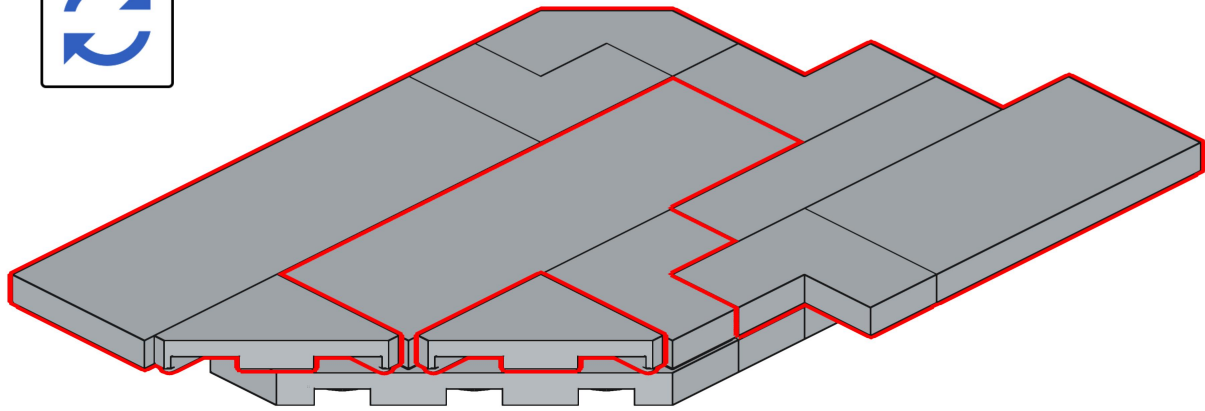
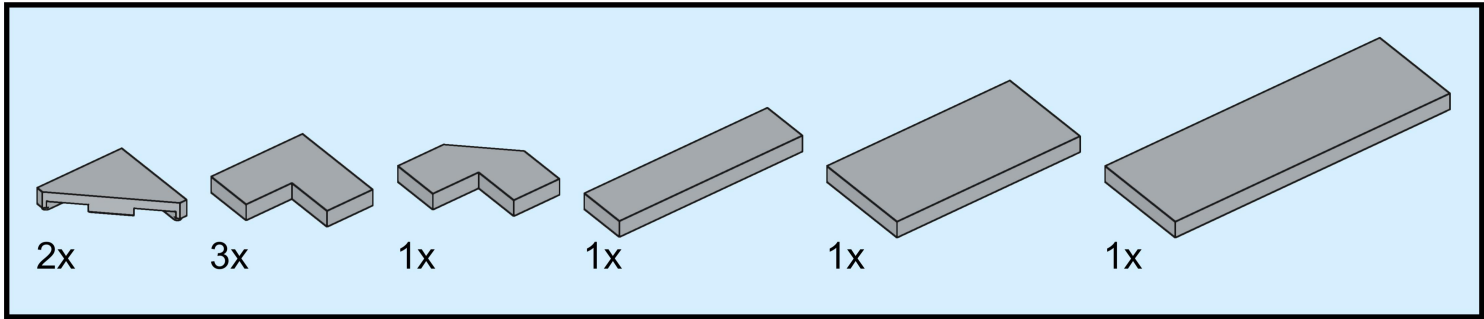

10

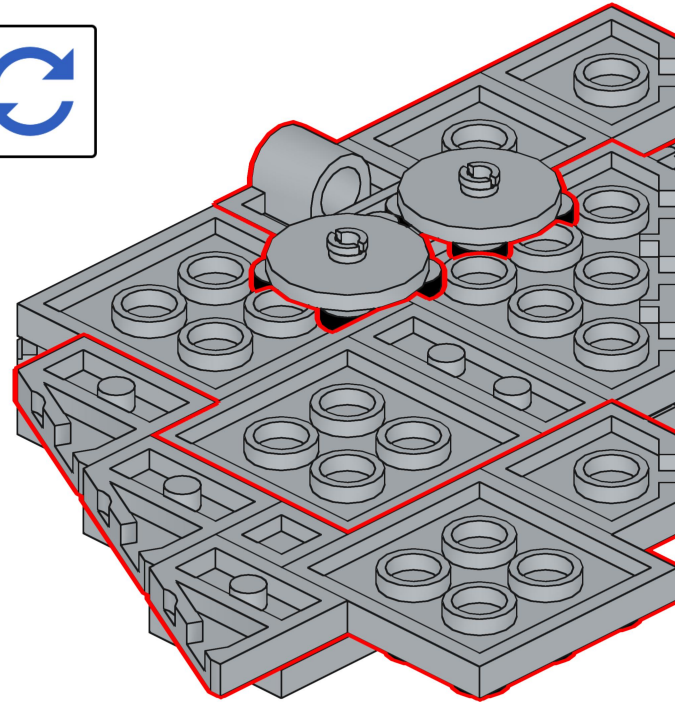
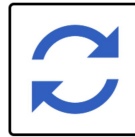
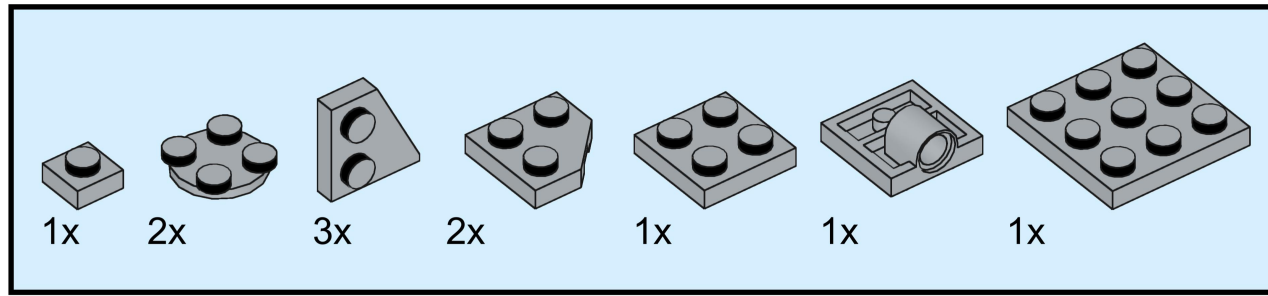

11

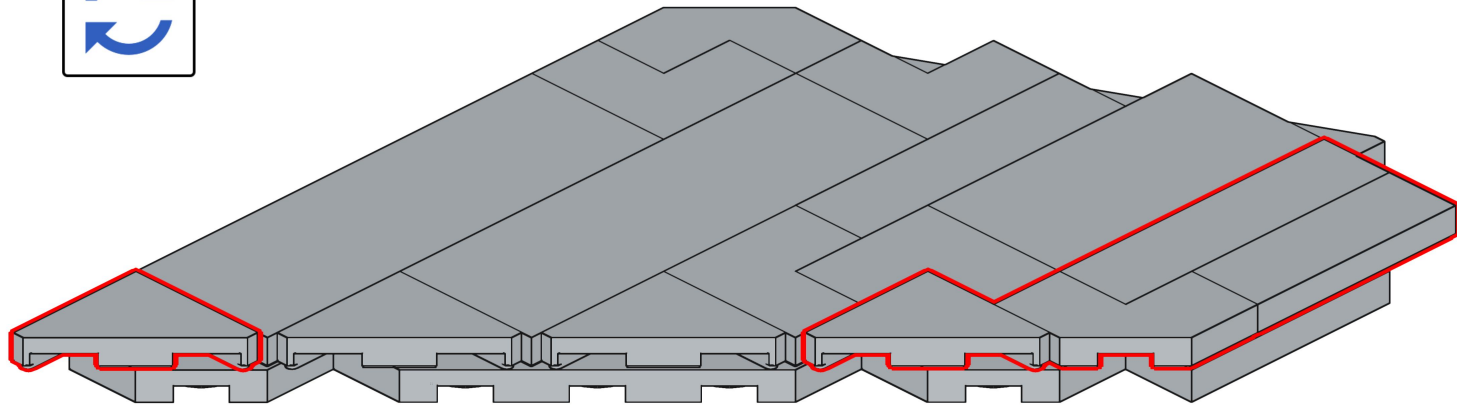
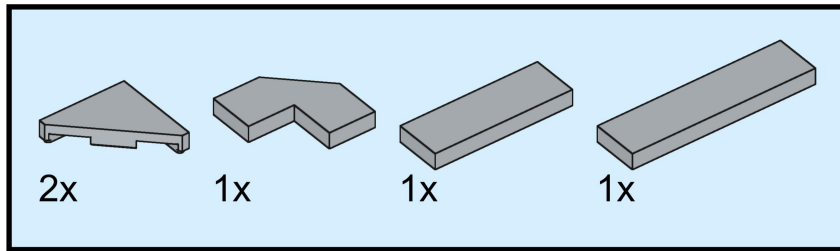

12

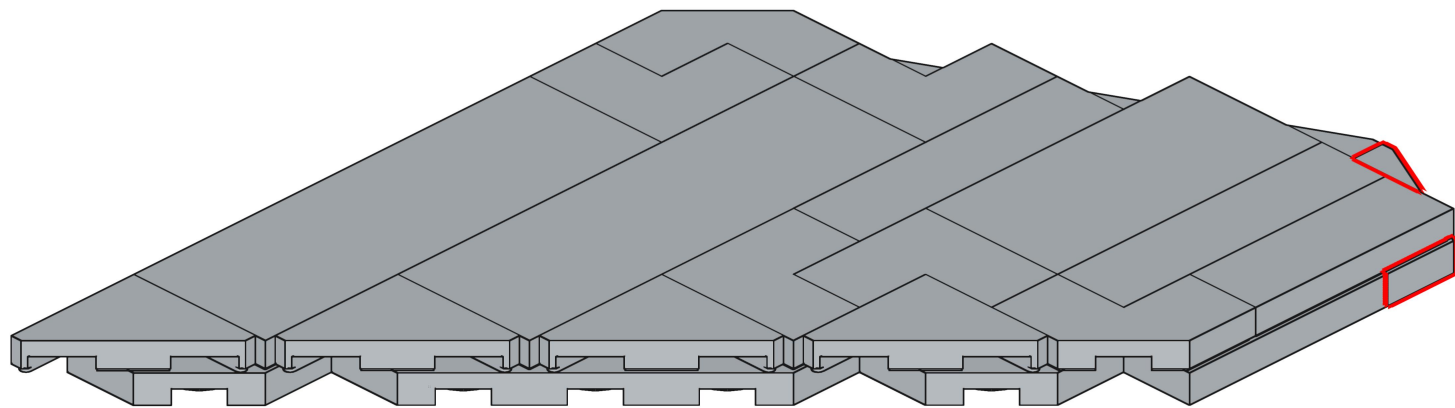
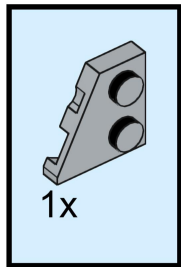

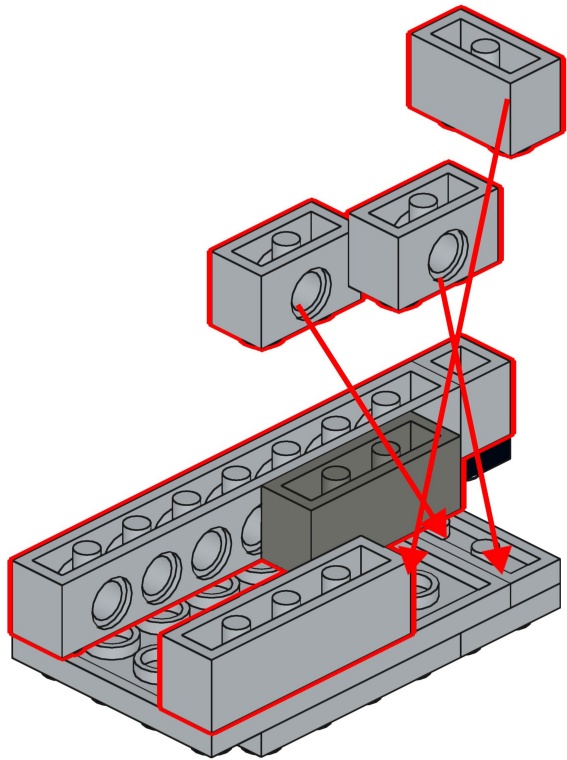

These three pieces must be rearranged on both sides of the engines in order to move the technic pin hole one stud further to the rear.

Here you can see the correct final location of these three pieces. Mirror the swap of these three pieces on the other engine.

