

2016-2018 CHEVROLET SILVERADO 1500 ECO SERIES FRONT BUMPER PART # GM-19336

PARTS LIST:

1	LD1 Front Bumper Assembly	6	12mm Lock Washers
1	Driver/left Frame Mounting Bracket	6	12mm Hex Nuts
1	Passenger/right Frame Mounting Bracket	2	12mm Nylon Lock Nuts
2	Tow Hook Extension Brackets	6	10-1.5mm x 35mm Hex Bolts
4	Spacers (tow hooks)	12	10mm x 27mm OD x 3mm Flat Washers
1	License Plate Bracket	6	10mm Lock Washers
2	Plastic Plugs for License Plate	6	10mm Hex Nuts
4	Sensor Retaining Caps	2	8mm x 25mm Hex Bolts
4	20mm x 10mm Foam Spacer	2	8mm x 16mm Hex Bolts
4	15.5mm x 25mm x 2mm Foam Sensor Seals	6	8mm x 24mm x 2mm Flat Washers
4	Sensor Plugs	4	8mm Lock Washer
1	GM Wire Harness Extension	2	8mm Hex Nut
1	Sensor Cover Kit	2	6mm x 20mm Button Head Bolts
1	Driver/left "L" Bracket (center LED light)	4	6mm x 18mm x 1.6 Flat Washers
1	Passenger/right "L" Bracket (center LED light)	2	6mm Nylon Lock Nuts
2	12mm x 30mm Double Bolt Plates	8	4mm Self Tapping Screws
2	12mm x 35mm Single Bolt Plates	1	4mm Wrench
2	12mm x 130mm Hex Bolts	10	Nylon Wire Ties
8	12mm x 24mm OD x 2.5mm Flat Washers		

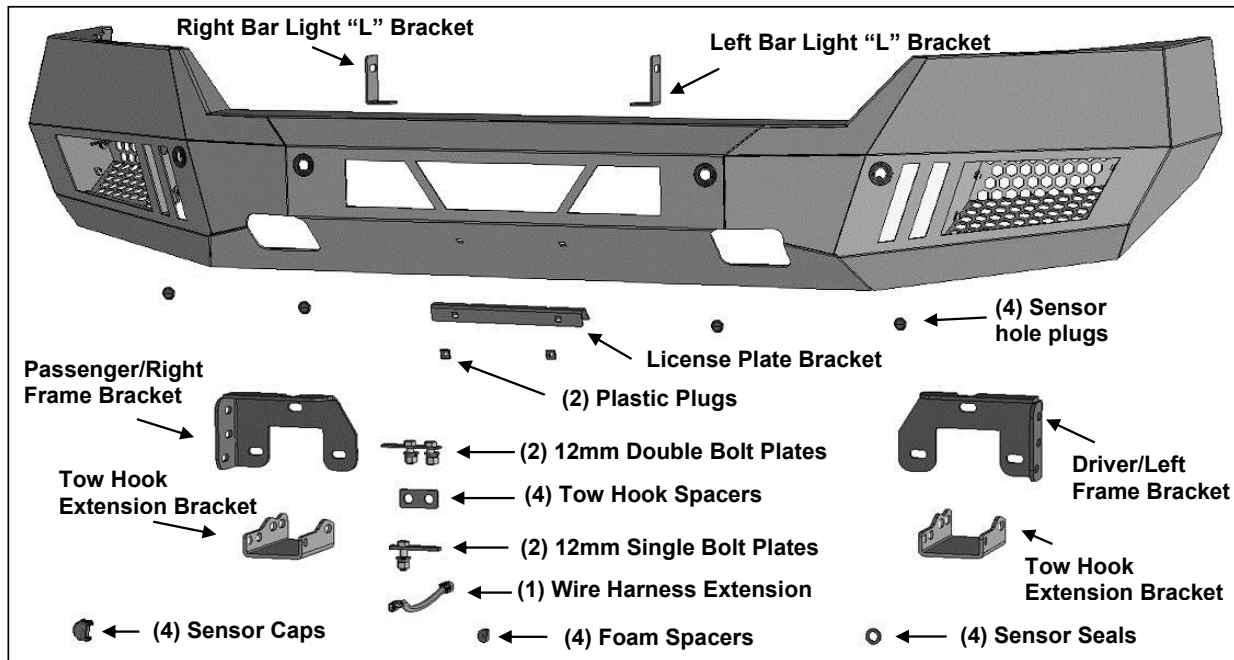

PROCEDURE:

REMOVE CONTENTS FROM BOX. VERIFY ALL PARTS ARE PRESENT. READ INSTRUCTIONS CAREFULLY BEFORE STARTING INSTALLATION. ASSISTANCE IS HIGHLY RECOMMENDED TO AVOID POSSIBLE INJURY OR DAMAGE TO THE VEHICLE.

1. Remove the license plate and bracket. On models with factory fog lights and/or bumper sensors, unplug the wiring harness leading to the bumper. Move harness away from bumper.
2. Open the hood and remove the plastic cover between the top of the radiator and the grille, (**Figure 1**). Next, carefully remove the grille from the vehicle. **NOTE:** Grille is held in place with screws at the top

- and several clips, **(Figure 1)**. Remove the screws and firmly pull the grille straight out from the vehicle to release the grille from the clips, **(Figures 2 & 3)**.
3. From behind the bumper, remove the outer bumper supports on each side of the frame, **(Figure 4)**.
 4. Place blocks or jack stands under the front bumper to support it during mounting bolt removal. Once the bumper has been safely supported, remove the bumper bolts attaching the bumper assembly to the frame bracket bolted to the end of the frame, **(Figure 5)**. **WARNING!** Assistance is required to hold the bumper in place during bolt removal to prevent the bumper from falling. Carefully slide the bumper assembly off of the ends of the frame.
 5. Remove both bumper brackets from the end of the frame, **(Figure 6)**.
 6. Once bumper has been removed, reinstall the plastic grille and cover removed in **Step 2**.
 7. Determine if vehicle is equipped with tow hooks

Models without tow hooks, skip ahead to Step 8.

Models with tow hooks:

- a. Remove the passenger/right tow hook, **(Figure 6)**.
 - b. Select (1) Single Bolt Plate and (1) Double Bolt Plate, **(Figure 7)**.
 - c. Select (1) Tow Hook Extension Bracket, **(Figure 8)**. Slide the Bracket over the end of the frame. Line up the slots in the Bracket with the factory tow hook mounting holes. Insert the Bolt Plates into the open end of the passenger/right side of the frame and out through the holes in the side and Bracket.
 - d. Secure the Bracket to the Bolt Plates with (3) 12mm Flat Washers, (3) 12mm Lock Washers and (3) 12mm Hex Nuts, **(Figures 8—10)**. Do not fully tighten at this time.
 - e. Place the tow hook on top of the Extension Bracket. Slide (1) Spacer Plate between each side of the tow hook and the Bracket. Reuse the short factory hex bolt to attach the rear of the tow hook. Attach the front of the tow hook to the Extension Bracket with (1) 12mm x 130mm Hex Bolt, (1) 12mm Flat Washer and (1) 12mm Nylon Lock Nut, **(Figures 8—10)**. Fully tighten tow hook and Extension Bracket hardware only. Do not tighten Frame Bracket hardware at this time.
 - f. Repeat previous **Steps** to install the driver/left side Extension Bracket and tow hook.
8. Select the passenger/right Frame Bracket. Reuse the (3) factory bumper bolts to attach the Frame Bracket to the threaded bumper mount, **(Figures 9 & 10)**. Do not fully tighten hardware at this time. Repeat to install the driver/left side Frame Bracket.
 9. Determine if the vehicle is equipped front sensors:

Models without bumper sensors:

- a. Select the included (4) Plastic Plugs.
- b. From the front, push the plugs into the sensor mounting holes, **(Figure 11)**.

Models with bumper mounted sensors:

- a. Disassemble front bumper to unplug and remove sensors and wiring harness from bumper.
 - b. Select (1) sensor. Remove the silicone seal from the end of the sensor. Slide the included larger Foam Sensor Seal over front of sensor, **(Figure 12)**.
 - c. Insert sensor with Seal into sensor mount, **(Figure 13)**.
 - d. Place Foam Spacer over end of sensor. Push Sensor Retaining Cap onto sensor mount and lock into mounting holes, **(Figure 13)**.
 - e. Repeat previous Steps to install remaining sensors.
 - f. Install wiring harness for sensors. **NOTE:** it may be necessary to remove some of the protective wrap around the harness to reach all sensor mounts. **NOTE:** Use the included (1) Wire Harness Extension to extend the reach of the factory harness as needed.
 - g. **Optional:** Secure each sensor to the socket with (2) 4mm Self Tapping Screws, **(Figure 8)**. **IMPORTANT:** Sensors fit snug in sockets. The 4mm Screws are used to apply slight pressure to lock the sensors in place. Tighten both screws evenly until they touch the sensor body only. Do not overtighten screws or damage to sensors will result.
10. If front license plate is required, attach the License Plate Bracket to the holes in the bumper with the included (2) 6mm x 20mm Button Head Screws, (4) 6mm Flat Washers and (2) 6mm Nylon Lock Nuts. Insert (2) Plastic Plugs into the square holes in the Bracket. Reuse the factory screws to attach the license plate to the Plastic Plugs, **(Figure 14)**.
 11. **Center LED light installation** (sold separately).

- a. Select the L/R "L" Brackets, (**Figure 15**). Attach the Brackets to the top of the (2) mounting tabs welded onto the back of the bumper with the included 8mm x 25mm Hex Bolts, (4) 8mm Flat Washers, (2) 8mm Lock Washers and (2) 8mm Hex Nuts. Leave loose at this time.
 - b. Attach the LED light assembly to the "L" Brackets with the included (2) 8mm x 16mm Hex Bolts, (2) 8mm Lock Washers and (2) 8mm Flat Washers, (**Figure 15**). Do not fully tighten hardware at this time. **IMPORTANT:** "L" Brackets are designed for 8mm light mounting hardware only. Modify "L" Brackets or use brackets supplied by the light manufacturer, if possible, to install hardware larger than 8mm.
 - c. Follow light manufacturer's instructions to properly wire the light.
- 12. LED light installation at ends of bumper** (sold separately).
- a. Insert light into opening and up to mounting slots in the top of the passenger/right light opening.
 - b. Check for clearance between front and back of light. If necessary, remove the screen from the back of the opening, (**Figure 16**).
 - c. Follow the light manufacturer's instructions to attach (1) light to the center slot or (2) lights to the inner and outer slots in the top of the light opening. **IMPORTANT:** On two light systems with (1) flood and (1) spot light per side, attach the flood to the outer and the spot light to the inner slot.
 - d. Repeat the above steps for driver/left side light installation.
 - e. Follow light manufacturer's instructions to properly wire the light.
- 13.** With assistance, position the Bumper Assembly up to and over the Frame Brackets. Temporarily support the weight of the Bumper. **WARNING:** To avoid possible injury or damage to the vehicle, do not proceed until the Bumper is fully and safely supported.
- 14.** Line up the (3) holes in the passenger/right side mounting plate on the back of the Bumper with the (3) slots in the Frame Bracket. Attach the Bumper to the Bracket with the included (3) 10mm x 35mm Hex Bolts, (6) 10mm Flat Washers, (3) 10mm Lock Washers and (3) 10mm Hex Nuts, (**Figures 17 & 18**). Do not fully tighten hardware at this time. Repeat this **Step** to attach the driver/left side of the Bumper to the Frame Bracket.
- 15.** Level and adjust the bumper and fully tighten all hardware.
- 16.** Do periodic inspections to the installation to make sure that all hardware is secure and tight.

To protect your investment, Do not use any type of polish or wax that may contain abrasives that could damage the finish. Mild soap may be used to clean the Front Bumper assembly.

Passenger/Right Side Installation Pictured



(Fig 1) Remove cover between radiator and grille. Remove screws attaching top of grille



(Fig 2) Firmly pull grille straight out from vehicle

Passenger/Right Side Installation Pictured

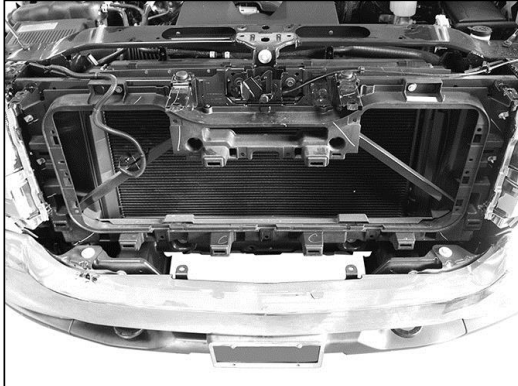

(Fig 3) Grille removed to access top bumper bolts



(Fig 4) Remove outer bumper support brackets

WARNING! Do not crawl under bumper unless it is properly supported on blocks or stands or the bumper may fall.

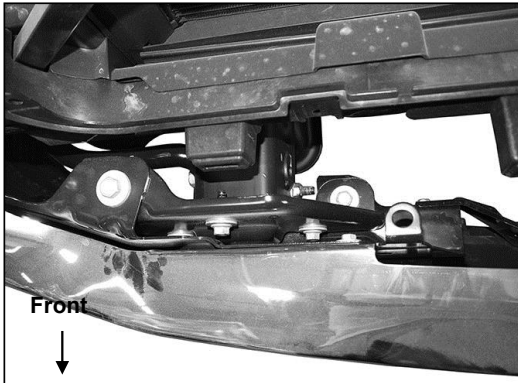

(Fig 5) Remove bumper bolts attaching bumper to brackets- passenger side pictured from above



(Fig 6) Remove factory bumper brackets and tow hooks if equipped



(Fig 7) 12mm Single Bolt Plate and 12mm Double Bolt Plate

Passenger/Right Side Installation Pictured

Double Bolt Plate
(2) 12mm Flat Washers
(2) 12mm Lock Washers
(2) 12mm Hex Nuts

Single Bolt Plate
12mm Flat Washer
12mm Lock Washer
12mm Hex Nut

WARNING! Do not crawl under bumper unless it is properly supported on blocks or stands or the bumper may fall.

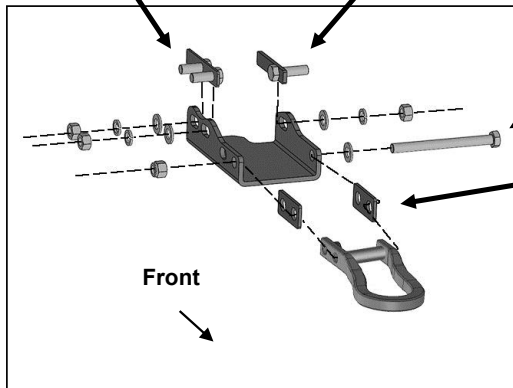

12mm x 130mm Hex Bolt
12mm Flat Washer
12mm Nylon Lock Nuts

Insert Spacers between sides of tow hook and Bracket

(Fig 8) Attach Tow Hook Extension Bracket to bottom of frame. Slide a Spacer between each side of tow hook



(Fig 9) Attach Tow Hook to Extension Bracket

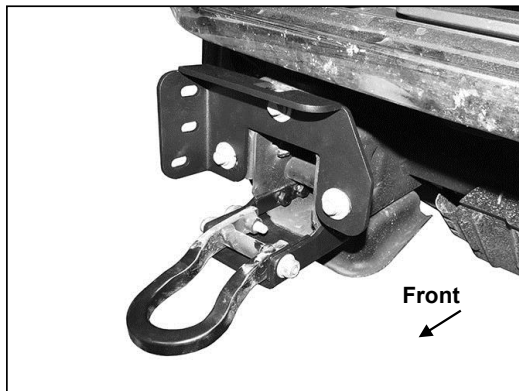

(Fig 10) Reuse factory hardware to attach Frame Bracket

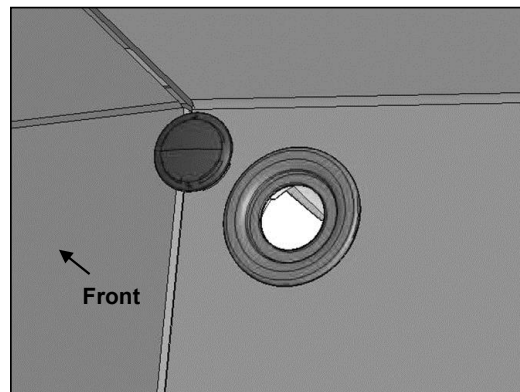

(Fig 11) Models without sensors, push sensor plug into mount

Passenger/Right Side Installation Pictured

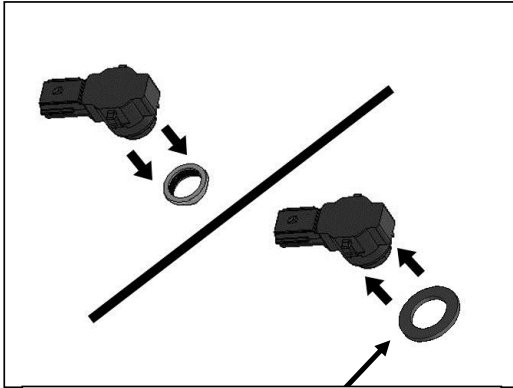

(Fig 12) Remove silicone seal from sensor. Slide large Seal over end of sensor (arrow)

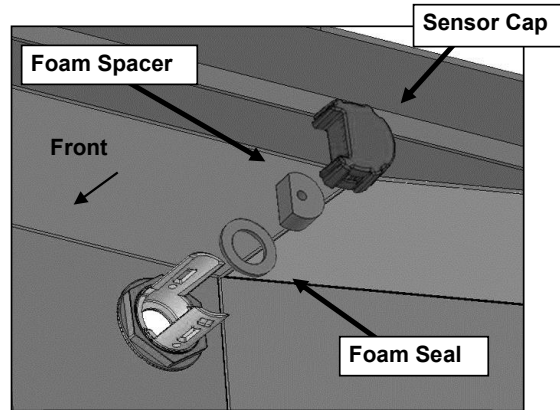

(Fig 13) Slide sensor into sleeve, insert Foam Spacer and snap on Cap to lock sensor in sensor mount

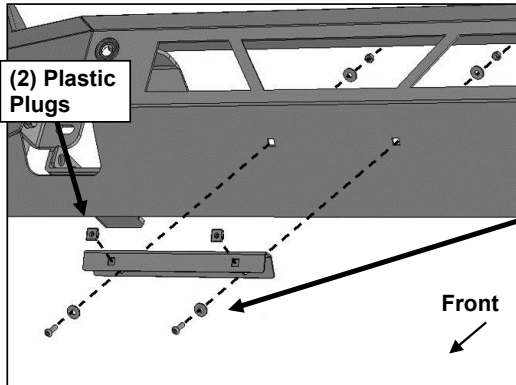

(Fig 14) Attach License Plate Bracket to Bumper

- (2) 6mm x 20mm Button Head Screws
- (4) 6mm Flat Washers
- (2) 6mm Nylon Lock Nuts

- (2) 8mm x 16mm Hex Bolts
- (2) 8mm Lock Washers
- (2) 8mm Flat Washers

- (2) 8mm x 25mm Hex Bolts
- (4) 8mm Flat Washers
- (2) 8mm Lock Washers
- (2) 8mm Hex Nuts

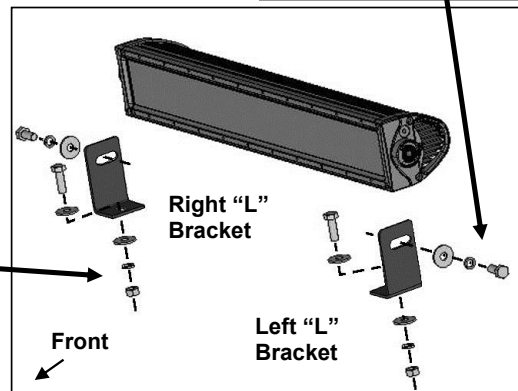

(Fig 15) Typical center light installation

Passenger/Right Side Installation Pictured

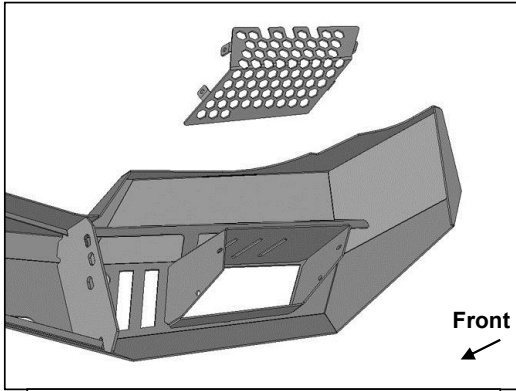

(Fig 16) Remove screens, if necessary, for clearance/access to outer light mounts

- (3) 10mm x 35mm Hex Bolts
- (6) 10mm Flat Washers
- (3) 10mm Lock Washers
- (3) 10mm Hex Nuts

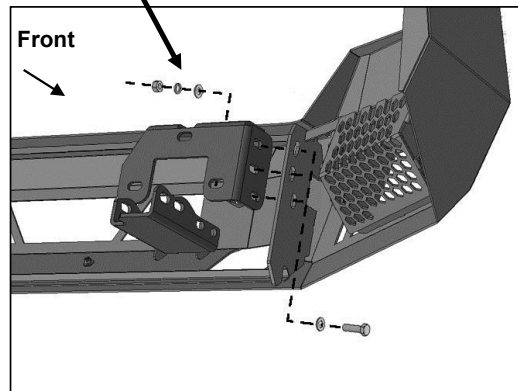

(Fig 17) Attach the Bumper to Frame Bracket

- (3) 10mm x 35mm Hex Bolts
- (6) 10mm Flat Washers
- (3) 10mm Lock Washers
- (3) 10mm Hex Nuts

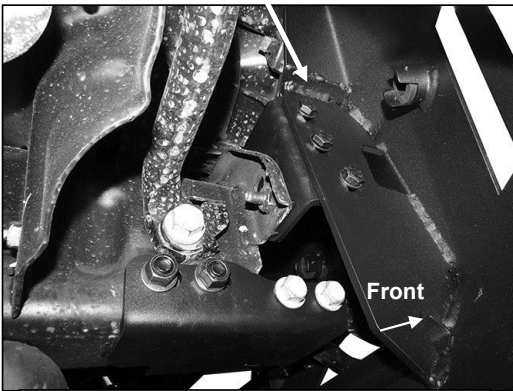

(Fig 18) Attach Bumper to Frame Brackets

