



Cladding

INSTALLATION GUIDE

THERMORY[®]
LEAVE A LASTING IMPACT

▶ COLOR ON BENCHMARK ASH, SCOTS PINE AND SPRUCE

The color of Thermory® Ash, Scots Pine and Spruce is not resistant to UV light. Nevertheless, wood that has turned silver/grey is not less resistant to decay. To maintain the original color for a longer time we recommend applying Cutek Extreme® and a complimentary Colortone. Cutek Extreme® by itself is not UV resistant. A light sanding or application of Cutek Proclean will remove the surface silvering and restore the original wood tones.

Factory-Applied coatings always produce the best results, as coatings applied uniformly to all six sides provide the best long term performance – ask Thermory USA about having your products factory-oiled before delivery.

▶ COLOR DIFFERENCES AND SHAPE DISTORTION

Color and grain differences between boards may occur and is typical with natural wood products. These differences are no reason for a claim. Shape distortion of Thermory® is significantly less common than for untreated wood. Minor distortions can however occur, and are no reason for a claim. Color of boards can change at different rates depending on amount of UV rays, rain, shade, climate, orientation to sun, etc.

▶ STORAGE

Whenever possible, Thermory® should be stored inside, out of the weather and sun. When this is not possible, Thermory® needs to be elevated off the ground, stacked uniformly and covered with a waterproof tarp. Leave the ends of the tarp open so moisture is not trapped inside, making certain the stored wood is not subjected to the elements or sun as the UV rays will fade the material. Under no circumstances should Thermory®, even in original packaging, be subjected to rain or any moisture as it cannot dry properly when stacked and/or packaged.

▶ CRACKS

Thermory® can show hairline cracks. These are normally not wider than 1/16” and are not limited in length. Surface hairline cracks are a natural occurrence with wood and are no reason for a claim. The surface of correctly installed Thermory® will always swell and shrink faster than its core causing the hairline cracks during the shrinking process. Due to the growing conditions of the wood, some boards will experience more hairline-cracking than others. Regular application of Cutek Extreme can help minimize the occurrence of surface hairline cracks. Please be sure to follow the application guidelines provided by the oil manufacturers. Note that the amount of application, temperature, drying time and frequency of rain can have a direct impact on the performance and appearance of the oil.



- ▶ When installing horizontal Thermory® Cladding, the tongue and groove boards must be installed with the tongue pointing upwards.
- ▶ Furring strips must be placed at least every 24" and a minimum of 3/4" thick if solid. They should be aimed to attach with studs when at all possible. Ventilation should be provided behind the boards. As an alternative Quarrix® furring strips may be used and purchased in conjunction with your Thermory® Cladding product.
- ▶ Fix horizontal cladding to vertical battens, the end of the board must sit on the batten. If JEM™ (joint end-matched) material is used, the ends can also be placed between the battens.
- ▶ Fix vertical cladding to horizontal battens, the end of the board must sit on the batten. If JEM™ (joint end-matched) is used, the ends can also be placed between the battens.
- ▶ It is recommended to leave minimum 12" gap at the bottom between the ground and cladding. At the very least the ventilation gap behind the cladding must stay open from below to ensure air circulation.
- ▶ In any case, we recommend to seal any raw ends of the board prior to installation to prevent water intake. It may be Cutek on raw cladding or matching paint or stain for painted products.

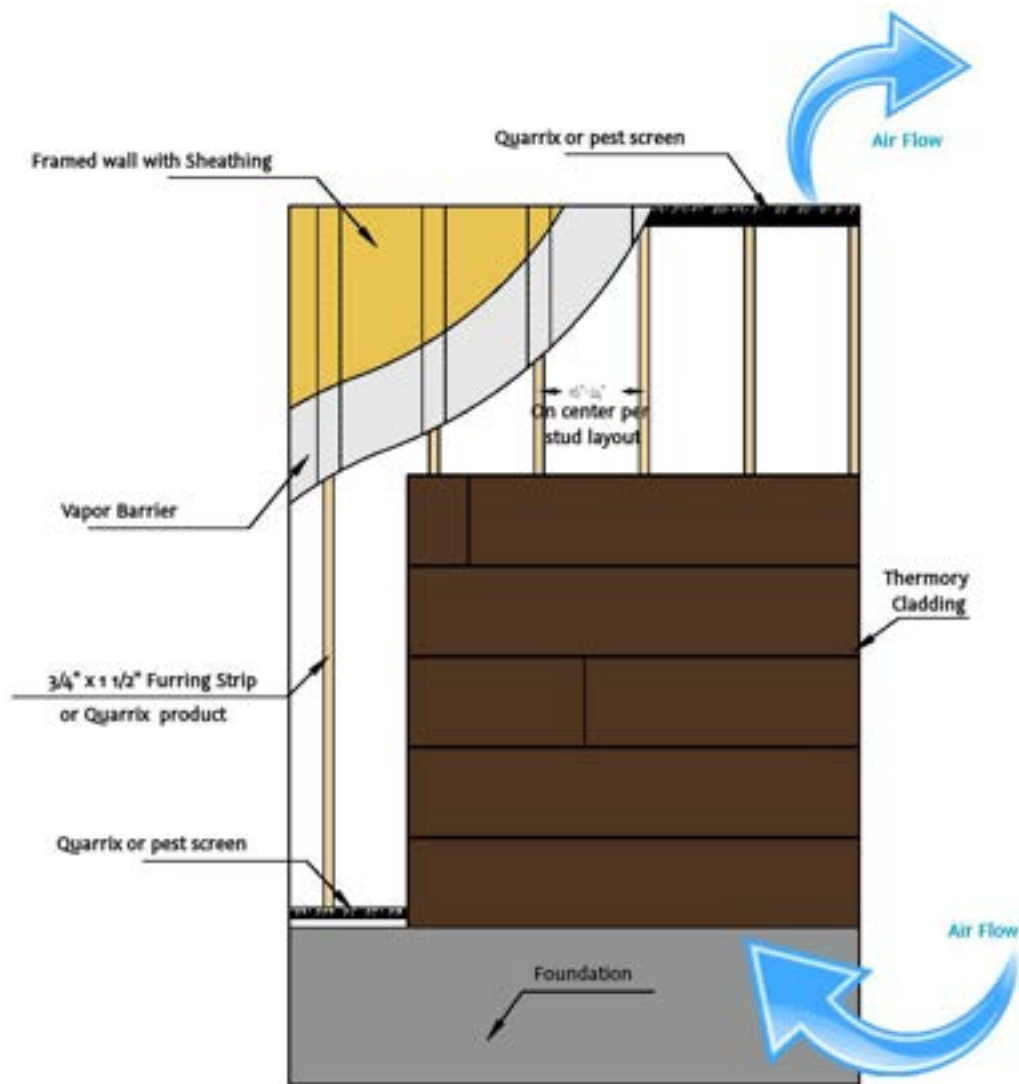

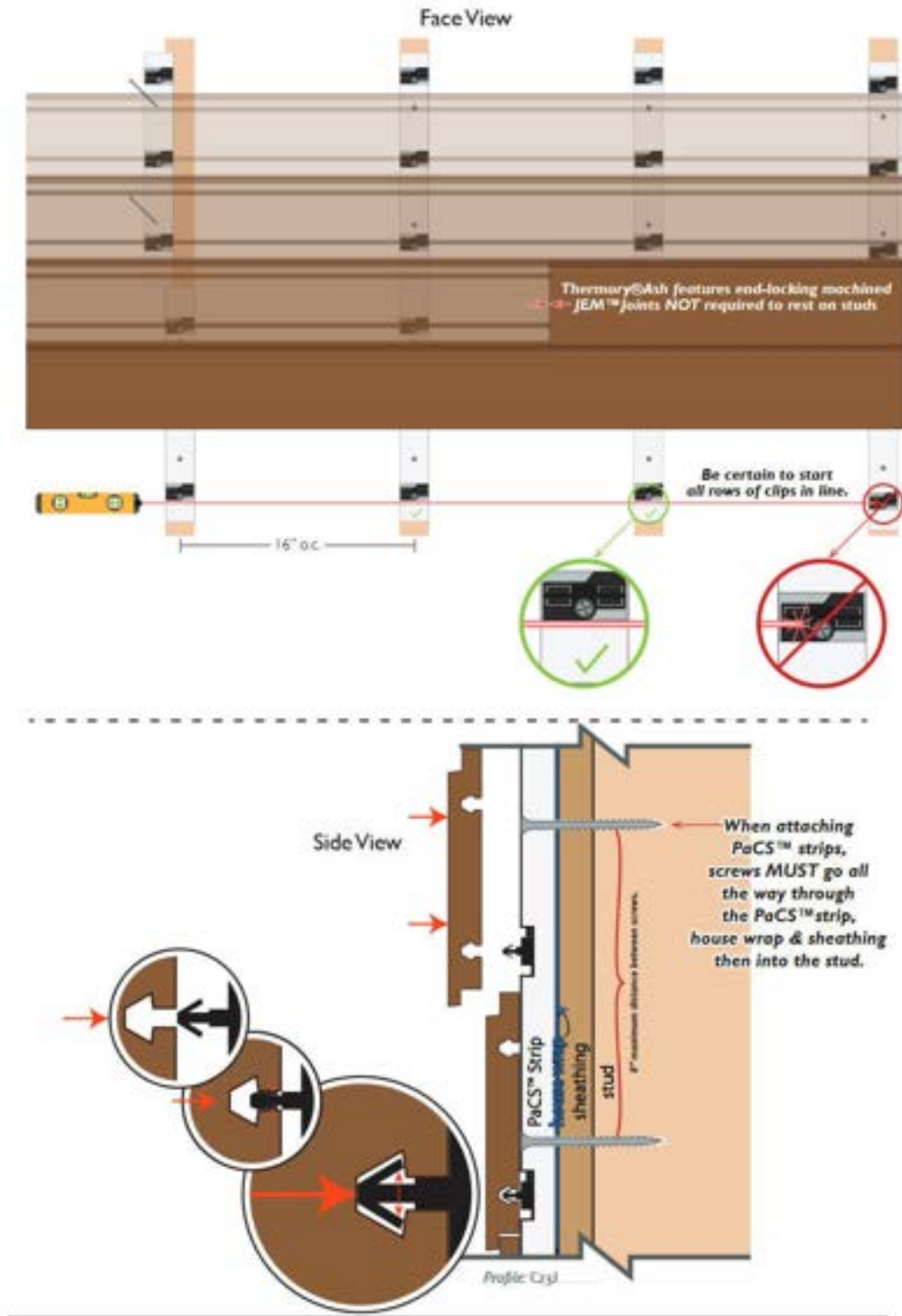



CALCULATING THE QUANTITY OF PaCS™ STRIPS NEEDED

- ▶ Cladding with 16" on center stud spacing: $\text{Sq.ft.}/10 = \text{number of PaCS™ strips needed.}$



- ▶ Thermory® C7J cladding utilizes a PaCS™ aluminum furring strip that is powder coated black to be visually appealing in the areas that the cladding exposes it.
- ▶ Fastening:
The manufacturer has recommended the rails to be fastened by these types of fasteners:

	Fastener Type	Usage
	#10-16 x 1 1/2" Self tapping screw	Direct fastening
	#8 or #10 x 1 5/8" Deck Screw	Predrill and screw
	0.148 x 1 1/2" Nail	Pneumatic Nail Gun

Linking Two Rails Together

- ▶ Due to aluminum expansion strips are not butted together like Thermory® PaCS™ wood furring strips. They are instead gapped utilizing a guide provided with your order.
1. Install initial full rail, level, and attach to the wall.
 2. Place second rail after first.
 3. Use guide over the clips to provide proper spacing.
 4. Use level to ensure proper alignment and fasten to the wall.
 5. Repeat this for every strip.



- ▶ A 1/16" gap should be provided between each board to allow for expansion in width on profiles without an expansion bead.
- ▶ A 1/32" gap should be provided between the end of the cladding and casing or trim to allow for expansion in length on profiles.

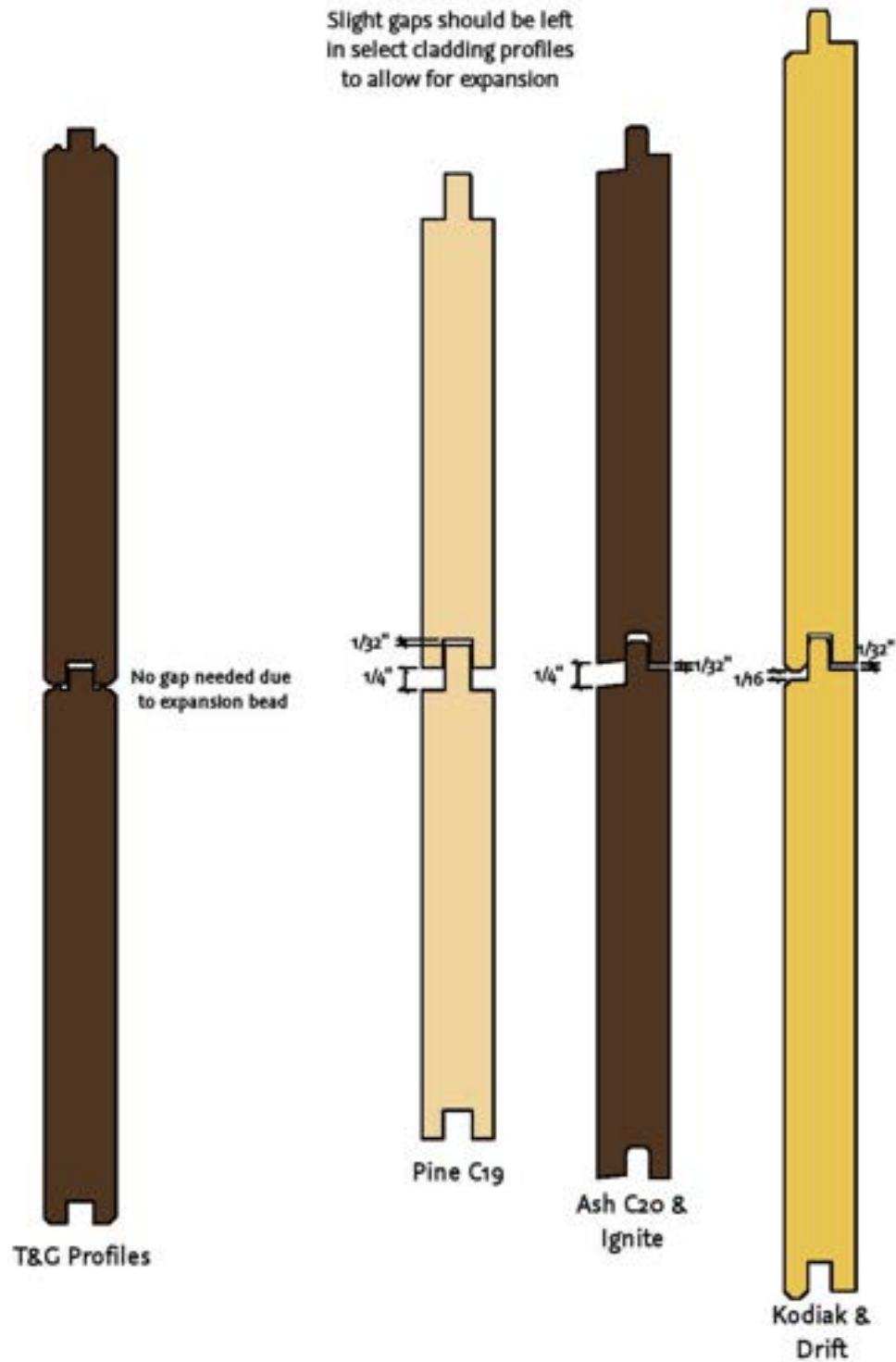

- ▶ Always use Fixing Group Solida 1 stainless steel screws, or PaCS™ powered by GRAD® for fixing Thermory® Cladding. Use of nails or staples is **NOT** recommended.
- ▶ Screw head must not penetrate too deep into the cladding and must be flush with the surface of the tongue to prevent excessive moisture absorption.

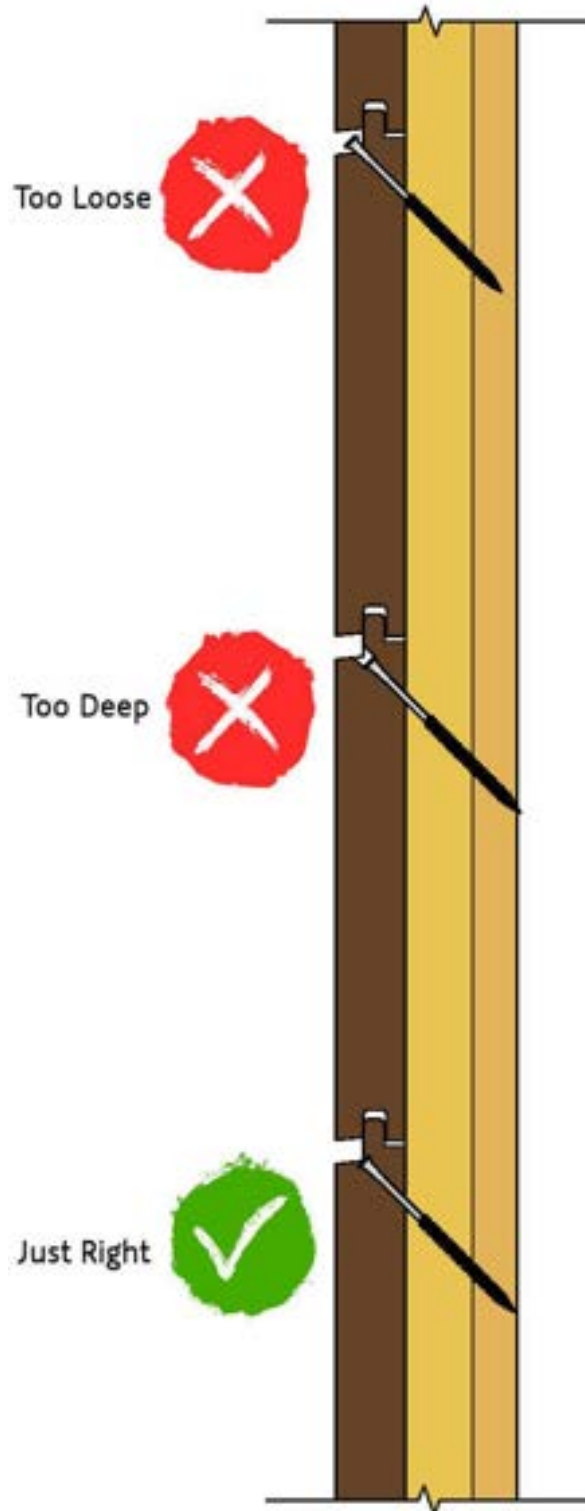

- ▶ In order to avoid splitting, leave a minimum of $3/4$ " of space from edge of the board.

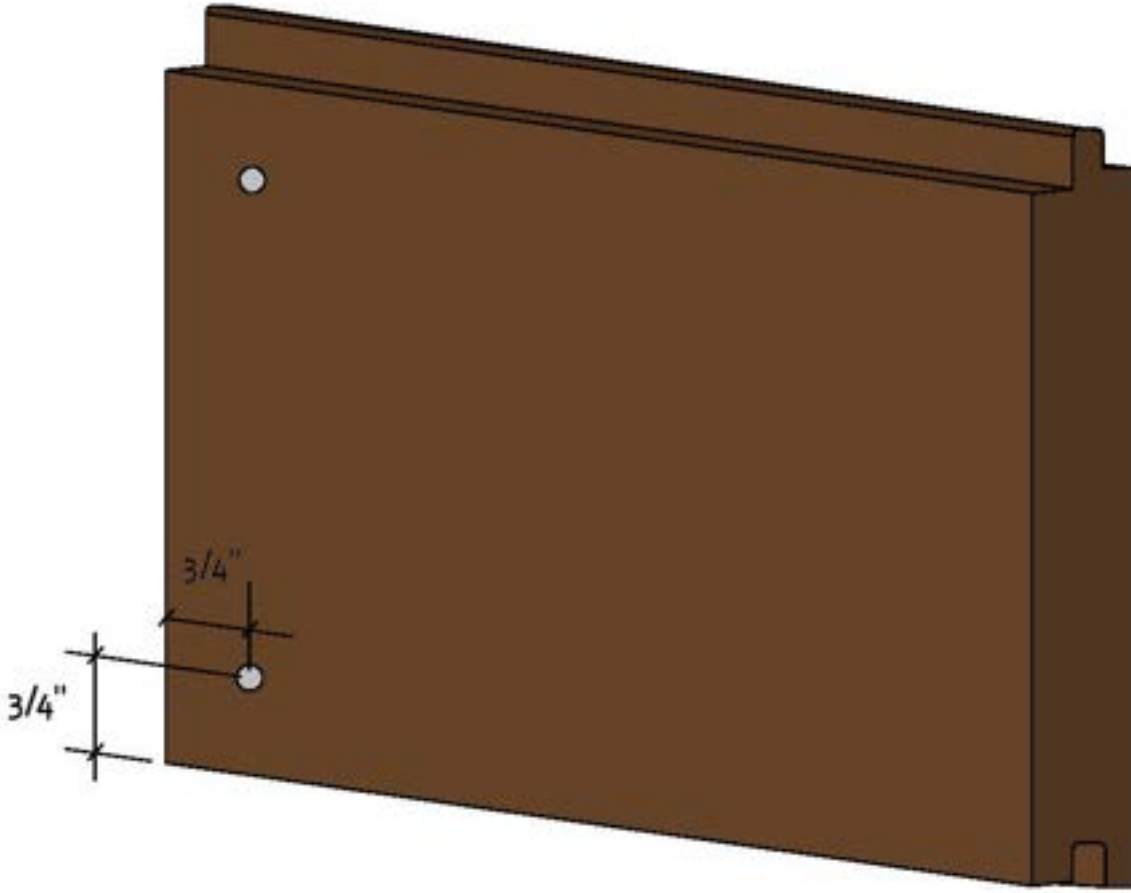

- ▶ One row of vertical furring strips must be applied to the sheathing before cladding can be installed to provide air flow behind cladding.
- ▶ Top and bottom must not be obstructed, leave at least 1/4" of gap from soffit on top or water table on bottom.

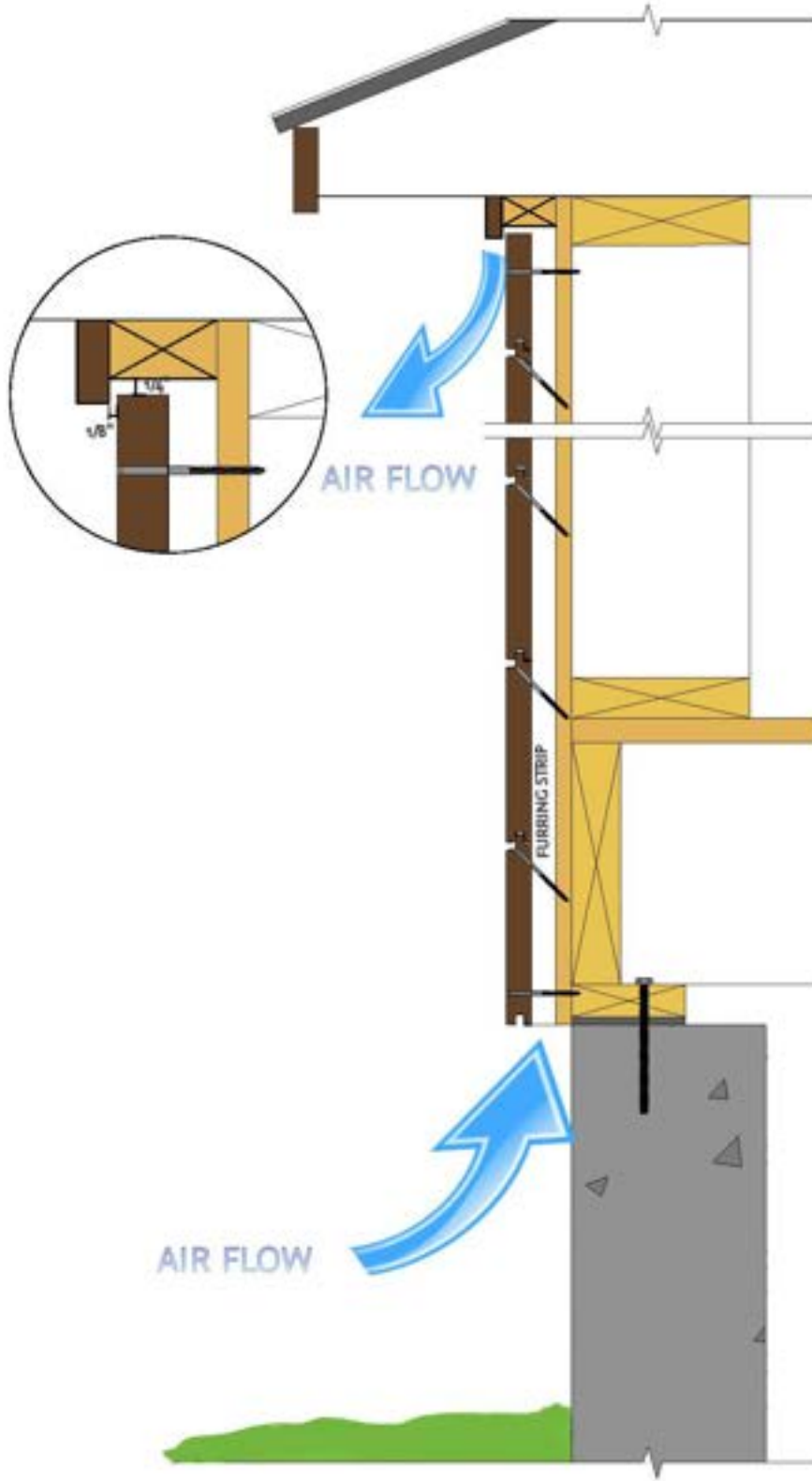

- ▶ One row of vertical furring strips must be applied to the sheathing followed by a horizontal row before cladding can be installed to provide air flow behind cladding.
- ▶ Top and bottom must not be obstructed, leave at least 1/4" of gap from soffit on top or water table on bottom.

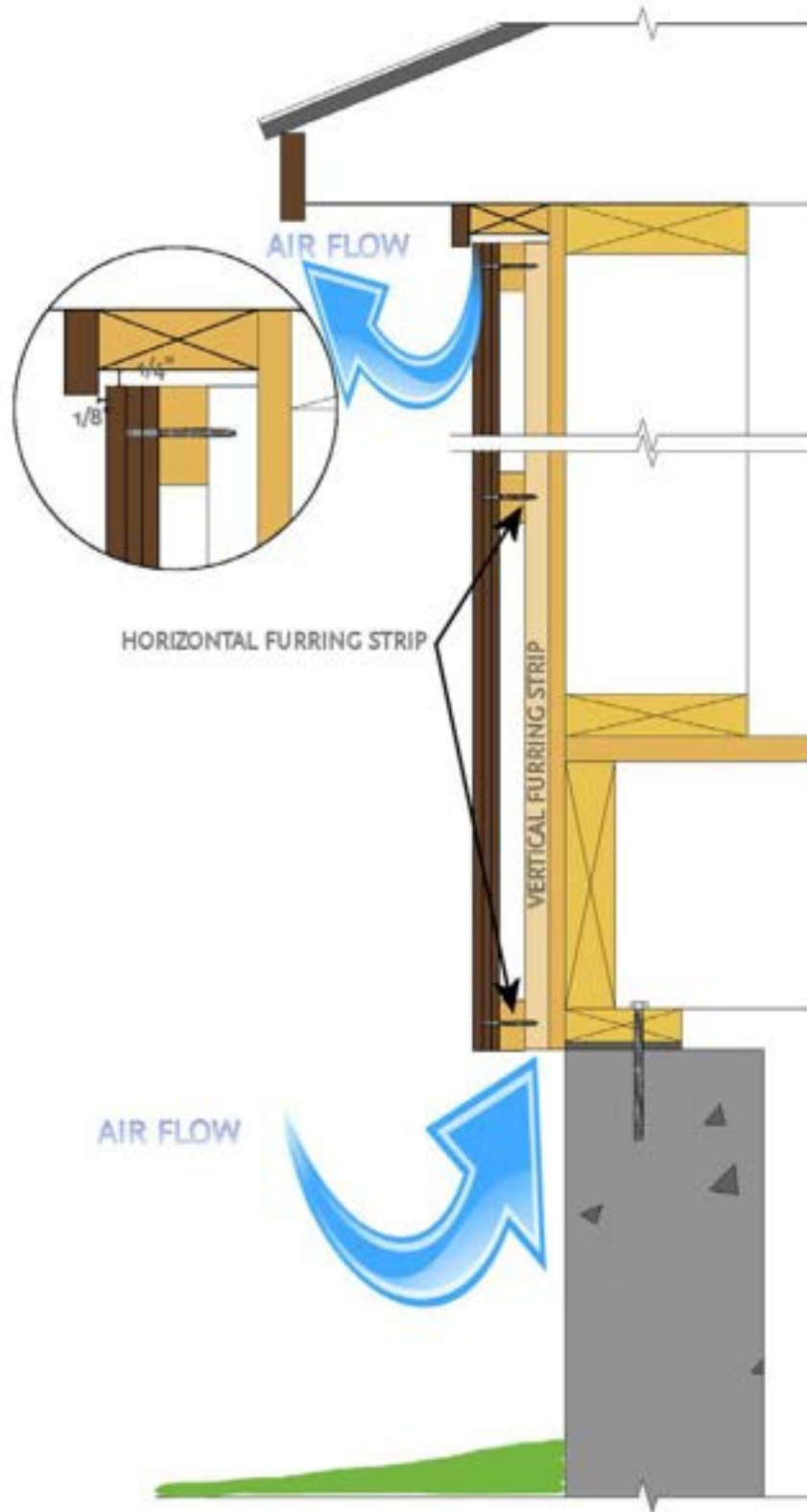



- ▶ Stop cladding 1/4" from top and bottom of windows and doors to allow air flow and drainage.



Thermory is committed to providing you with a quality product that performs exactly as we say it should. Thermory decking, cladding and porch flooring products are real wood which is likely one of the reasons you chose Thermory. Like any real wood product, it's not perfect. Wood products can react to their surrounding environment in natural ways that result in a less than perfect appearance. Our thermal modification process reduces common issues such as of severe cracks and moisture related movement, but will not prevent them completely. In comparable situations, Thermory will always perform better than other wood products in terms of rot and moisture related movement.

If you're experiencing issues with your Thermory project, we'd like for you to read through the installation guide again to ensure that the recommended guidelines were followed.

HERE ARE SOME COMMON CONCERNS AND THE REASONS FOR THE PRODUCT'S REACTION.

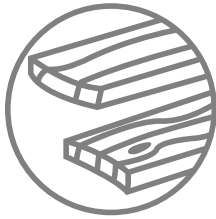

▶ CUPPING & CROWNING

Most cracks or warping occur with an imbalance of relative humidity above and below the deck. When the humidity below the deck is higher than the relative humidity of the ambient surroundings, the wood's cells on the bottom of the board will swell, causing cupping, evident when the board makes a "smiley face." Adversely when wood releases excess moisture this causes the wood to crown and cause a "frown face".

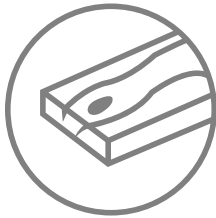

▶ CRACKING

Cracking and swelling in the opposite direction is most often because the exposed surface of the wood has been finished with a "film forming" or non-penetrating oil. Film forming finishes can cause the wood to trap moisture within the fiber over time, preventing the wood to "breathe" naturally and expel excessive moisture.



▶ COLOR CHANGE

All wood products will experience color change, even if they have been treated with a UV protectant product such as CUTTEK™ Extreme with colortones. The surface of wood can be considered similar to our skin. Even if we put an excessive amount of sunblock on our skin, under prolonged conditions our skin will eventually tan or burn. UV protectant will slow this dramatically but will never stop it all together. Without CUTTEK™ Extreme plus colortone, the color change will happen drastically faster. The color can be renewed completely, please refer to our website's [Maintenance Page](#).

The specific project application will make the speed of color change happen at considerably different rates. Decking will change in color much faster than cladding or fencing since the UV exposure to decking is more direct than cladding. Soffits and porch flooring will only turn grey when exposed to the combination of all three elements; water, sun and oxygen. When one is missing, wood may fade, but will not turn grey. Cladding will still turn grey, but at a slower rate, approximately half the rate of decking.





▶ **BLACK STAINING AT SCREW HOLES**

Stainless steel fasteners are required with Thermory products. Thermally modified wood has a higher acidity than non-modified wood or pressure treated wood and can cause non-stainless screws to corrode quickly. This corrosion can be seen as the chemical reaction bleeds into the grain with black staining.



▶ **CLADDING IS EXPANDING/BUCKLING OFF THE WALL**

When there is an imbalance in the relative humidity on the backside of the board versus the front of the board, this will cause the wood to cup. In most cases, the boards will swell on the back side of the board which means the top edges of the board will point outward. When the swelling is severe enough, and no longer has room to expand - the boards will eventually break.

This imbalance of relative humidity happens because there is a lack of ventilation behind the cladding. There needs to be clear and open ventilation at the bottom of the wall and running the entire height, venting at the top or into the soffit. Drainage mats historically do not provide adequate ventilation and free air movement.

If you feel adequate ventilation has been observed in the installation, then there is likely a source of water behind the wall, such as poor flashing at the soffit/cladding transition or around the windows.

In most cases, if breakage has not occurred, the cladding will right itself over time if the venting mistake has been corrected. The correct ventilation, or fixing the incorrect flashing installation will reduce the moisture behind the cladding, rebalancing the relative humidity and allowing the cladding to equalize and lay flat again.



▶ **COLOR IS BLEEDING FROM BOARDS AND STAINING LIGHT-COLORED SURFACES**

There are no chemicals in any of the Thermory species, however bleeding can still occur. As water, sun and oxygen engage with the surface of the wood, specific cells holding the wood's tannin become water soluble. This tannin is what gives the wood its color. As rain occurs, those tannins will bleed off the surface and run down the face of a building or drip to a surface below.

This will be more apparent on lighter colors, such as stone, marble or stucco. The tannins are completely organic and will likely wash away within a season. If nature's process isn't fast enough, a cleaner approved by the surface manufacturer may be used.



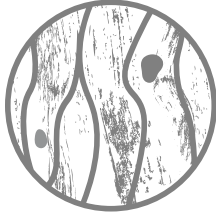

▶ **DRIFT PRODUCT LINE**

Drift products, such as Platinum and Black Pearl have a light finish applied and are intended to be an alternative to the look of reclaimed lumber. Over time, the initial coating on Drift will weather, exposing the thermally modified fiber beneath. This fiber will eventually take on a natural silver patina, ensuring an old-world reclaimed look that will endure for many years with minimal maintenance.

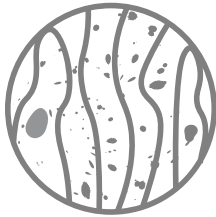

▶ **BLACK AND/OR GREEN SURFACE STAIN AND MOLD**

Black surface stains are caused by dirt, debris, pollen and other airborne and microscopic elements resting on the surface of the deck. Certain environments provide exceptional growing conditions for mold and fungus, conditions that often fall within, but are not limited to shaded decks or cladding. The black or green staining you are experiencing is likely this mold and fungus.

This is not a cause for concern, but it does mean you should be clearing the surface of your deck more often and taking additional preventative care considering surrounding conditions. It is important to remember the same occurrence can happen on any surface, such as rocks, glass, PVC, and composite products.

This staining is removable with light pressure washing and a renewing/cleaning agent. Cutek is the Thermory recommended product line and you can find cleaning options on our [CUTEK™ Page](#).

With proper installation and maintenance your Thermory product can perform well, but as with anything else in life there are always mishaps that can happen. We are here for any problems that may arise with your product and want to make sure you're satisfied while understanding the natural occurrences that can happen to real wood products.

