RS485 500cm Ultrasonic Level Sensor

Version: v1.0

Table of Content

| | |
|--|---|
| 1. Overview | 3 |
| 1.1. Summary | 3 |
| 1.2. Product feature and scope of application | 3 |
| 1.1.1 Features..... | 3 |
| 1.1.2 Scope of application | 3 |
| 2. Appearance description..... | 4 |
| 2.1. Schematic diagram of appearance..... | 4 |
| 2.2. PIN definition..... | 4 |
| 3. Module description | 4 |
| 4. Output methods description..... | 4 |
| 4.1. RS485 output method | 4 |
| 5. Module parameter | 6 |
| 5.1. Working parameters..... | 6 |
| 5.2. Rated environmental condition | 7 |
| 5.3. Rated electrical condition | 7 |
| 6. Reference diagram of effective detection range..... | 7 |
| 7. Reliability test conditions | 8 |
| 8. Matter needing attention..... | 9 |
| 9. Package size | 9 |
| 10. Packing specifications | 9 |

1. Overview

1.1. Summary

A12 module is a kind of module which uses ultrasonic sensor technology to measure distance. The module adopts high-performance processor and high-quality components, and the product is stable and reliable with long service life. The module uses waterproof ultrasonic transducer, which has strong adaptability to working environment. The module has built-in high-precision ranging algorithm and power management program, with high ranging accuracy, low power consumption, long measurement distance and small measurement angle.

A12 module, hereinafter referred to as "module".

1.2. Product feature and scope of application

1.1.1 Features

- Long distance measurement with small angle.
- It adopts intelligent signal processing circuit with small blind area.
- The minimum error is less than 5mm.
- The measurement angle is controllable, with high sensitivity and strong anti-interference ability.
- The built-in true target recognition algorithm has high accuracy of target recognition.
- The professional measurement mode can be set, which can be used for targeted measurement of human body or plane objects.
- Multiple output modes can be selected, including high-level pulse width output, UART output or switching value, with strong interface adaptability.
- On board temperature compensation function, automatically correct temperature deviation, ranging from - 15°C to + 60°C.
- Low power consumption design, static current < 15ua, measured state current < 10mA (5V power supply).
- Wide voltage power supply, suitable for 3.3~24 v.
- Static protection design, the output lead is added with electrostatic protection device, which conforms to IEC61000-4-2 standard.
- Operating temperature - 15°C to + 60°C.

1.1.2 Scope of application

- Horizontal Ranging
- Parking Management System
- Robot avoidance and automatic control
- Close and wide-angle object approach and presence detection

2. Appearance description

2.1. Schematic diagram of appearance

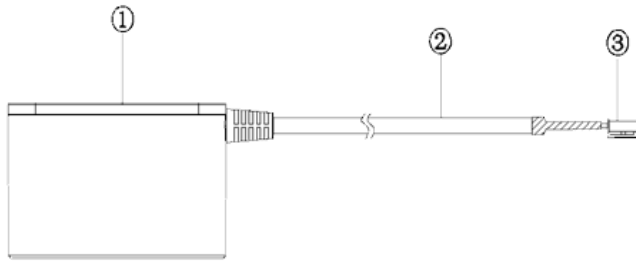

① Sensor ② Wire ③ HY2.0-4Y plug

2.2. PIN definition

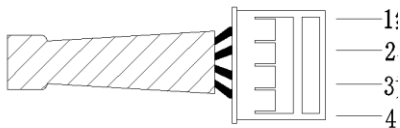

| PIN # | Color | PIN name | PIN description |
|-------|--------|----------|-----------------|
| 1 | Red | VCC | Power input |
| 2 | Black | GND | Ground |
| 3 | Yellow | B | RS485-B |
| 4 | White | A | RS485-A |

3. Module description

A12A series module is mainly used for plane ranging; it can be used for targeted measurement of plane objects, with long measuring distance, small measuring angle and high precision. The farthest measuring range of plane object is 500cm.

4. Output methods description

4.1. RS485 output method

4.1.1. PIN and command definition

| PIN # | Mark | Function description |
|-------|------|----------------------|
| 3 | B | RS485-B |
| 4 | A | RS485-A |

| | | | | |
|-------|-----------------|-----------------|---------------------|------------------|
| | data bit | stop bit | parity check | Baud rate |
| RS485 | 8 | 1 | None | 9600 |

| | | | | |
|-----------------|---------------|----------------------|---------------------------|----------------------------|
| Protocol | Check | Slave Address | Function code-Read | Function code-Write |
| Modbus-RTU | CRC-16/MODBUS | Default 0x01 | 0x03 | 0x06 |

Read command:

| | | | | | |
|------|----------------|-------------|-------------------------|------------------------|--------------------|
| | Address | 0x03 | Register address | Register number | CRC16 check |
| Byte | 1 | 1 | 2 | 2 | 2 |

Response

| | | | | | |
|------|----------------|-------------|--------------------|-------------|--------------------|
| | Address | 0x03 | Return byte | data | CRC16 check |
| Byte | 1 | 1 | 1 | N | 2 |

Write command:

| | | | | | |
|------|----------------|-------------|-------------------------|-------------|--------------------|
| | Address | 0x06 | Register address | data | CRC16 check |
| Byte | 1 | 1 | 2 | 2 | 2 |

Response

| | | | | | |
|------|----------------|-------------|-------------------------|-------------|--------------------|
| | Address | 0x06 | Register address | data | CRC16 check |
| Byte | 1 | 1 | 2 | 2 | 2 |

4.1.2. Modbus Register

| Status | Register address | Description | Type of data | Details |
|---------------|-------------------------|----------------------------------|---------------------|---|
| Read | 0x0100 | The calculated value of distance | UINT16 | After receiving the command, start ranging, after several ranging filtering processing, output distance value, unit: mm, response time is about 500ms |
| Read | 0x0101 | Real-time distance value | UINT16 | After receiving the instruction, the module starts the ranging, and directly outputs the real-time distance value, unit: mm, and the response time is about 100ms |
| Read | 0x0102 | Temperature | INT16 | Unit: 0.1°C, response time about 100ms |
| Read/Write | 0x0200 | Slave address | UINT16 | The value ranges from 0x01 to 0xFE. The default value is 0x01. |

| | | | | |
|--|--|--|--|--------------------------------------|
| | | | | 0xFF indicates the broadcast address |
|--|--|--|--|--------------------------------------|

4.1.3. Example

1) Read the calculated value of distance:

Command: 01 03 01 00 00 01 85 F6

Return: 01 03 02 02 F2 38 A1

Description: The slave address is 0x01, the calculated value of distance is 0x02F2, convert to decimal is 754, the distance value = 754mm

2) Read the real-time distance value:

Command: 01 03 01 01 00 01 D4 36

Return: 01 03 02 02 EF F8 A8

Description: The slave address is 0x01, the real-time distance value is 0x02EF, convert to decimal is 751, the distance value = 751mm

3) Read the temperature value:

Command: 01 03 01 02 00 01 24 36

Return: 01 03 02 01 2C B8 09

Description: The slave address is 0x01, the temperature is 0x012C, convert to decimal is 300, the temperature value=30.0°C

4) Modify the slave address

Command: 01 06 02 00 00 05 48 71

Return: 01 06 02 00 00 05 48 71

Description: Change the address 0x01 to 0x05.

5. Module parameter

5.1. Working parameters

| Parameters | A12A | Unit | Remarks |
|-------------------------------|-------------|------|---------|
| Operating voltage | 3.3~24 | V | DC |
| Static current | <5 | mA | |
| Operating current | <10 | mA | |
| Measuring continue duration | ≤50 | ms | |
| Blind spot distance | 25 | cm | (1) |
| Flat object measurement range | 25~500 | cm | (1) |
| Reference angle | ≈21° | - | (2) |
| Measurement accuracy | ±(1+s*0.3%) | cm | (3) |
| Temperature compensation | Compensate | - | |

Note:

(1) The temperature is 25 ± 5 °C, the measured object is a 50cm × 60cm flat carton, and the transducer should be perpendicular to the measured object as much as possible.

(2) The test object is the reference data of the white PVC pipe with a distance of 100 cm and the diameter of 75 mm × 100 cm.

(3) The temperature is 25 ± 5 °C, the measured object is 50cm x 60cm flat carton, s is the measurement distance.

5.2. Rated environmental condition

| Items | Minimum | Typical value | Maximum | Unit | Remarks |
|-----------------------|---------|---------------|---------|------|---------|
| Storage temperature | -25 | 25 | 80 | °C | |
| Storage humidity | | 65% | 90% | RH | (1) |
| Operating temperature | -15 | 25 | 60 | °C | |
| Operating humidity | | 65% | 80% | RH | (1) |

Note:

(1) a. when the ambient temperature is 0-39 °C, the maximum humidity is 90% (non-condensing).

b. When the ambient temperature is 40-50 °C, the maximum humidity is the highest natural humidity (non-condensation) under the current temperature.

5.3. Rated electrical condition

| Items | Specification | | | Unit | Remarks |
|-------------------|---------------|---------------|------------------|------|--------------|
| | Minimum | Typical value | Maximum | | |
| Operating voltage | 3.2 | 5.0 | 24 | V | |
| Peak current | 30 | | 50 | mA | Peak to peak |
| Input ripple | | | 50 | mV | Peak to peak |
| Input noise | | | 100 | mV | Peak to peak |
| ESD | | | $\pm 200/\pm 2K$ | V | (1) |
| ESD | | | $\pm 4K/\pm 8K$ | V | (2) |

Note:

(1) Assemble line body static electricity specification, contact static electricity should not be higher than $\pm 200V$, air static electricity should not be higher than $\pm 2KV$.

(2) The probe shell and output lead comply with IEC61000-4-2 standard.

6. Reference diagram of effective detection range

6.1. The object to be tested is PVC white cylindrical tube with a height of 1000mm and a diameter of 75mm.

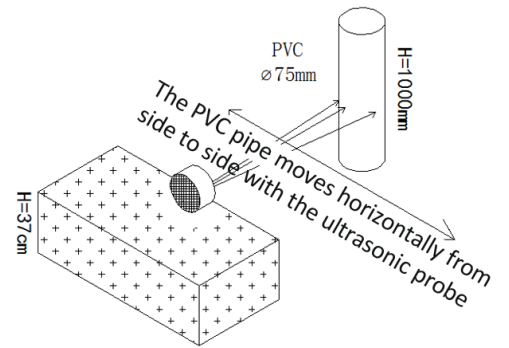
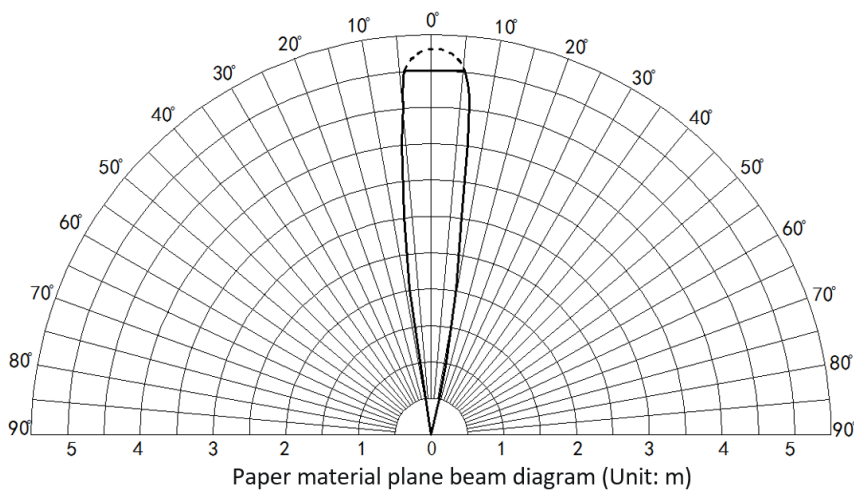

6.2. The object to be tested is "corrugated box", which is perpendicular to the 0° axis, and the length * width is 60cm * 50cm.

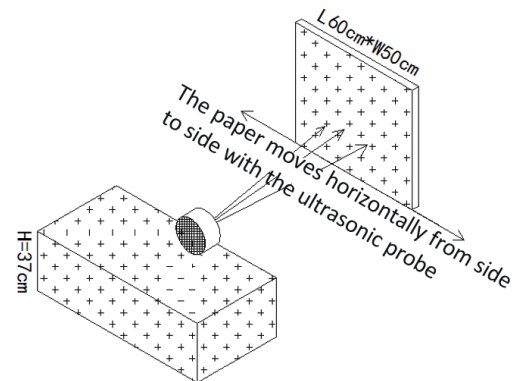
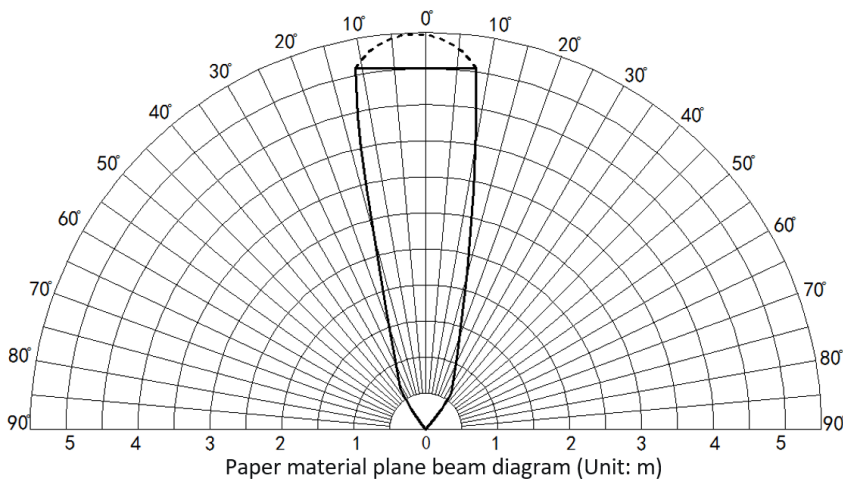

7. Reliability test conditions

| Items | Test content | Experimental condition | Samples | Remarks |
|-------|---------------------------------------|---|---------|---------|
| 1 | High temperature and humidity | 65°C, 85% RH, power ON@24V , 72hrs | 3 | |
| 2 | Low temperature operation | -20°C, power ON@24V , 72hrs | 3 | |
| 3 | High temperature and humidity storage | 80°C, 80% RH, storage, 72hrs | 3 | |
| 4 | Low temperature storage | -30 °C, storage, 72hrs | 3 | |
| 5 | Vibration test | 10-200hz, 15min, 2.0g, XYZ three axes, 0.5h for each axis | 3 | |
| 6 | Drop test | 1.2m free fall, 5 times @ wooden floor | 3 | |

Note: after the test, the module is judged to be OK after passing the function test, and the performance degradation rate is less than or equal to 10%.

8. Matter needing attention

1. The module will assemble the net cover by default. If the net cover cannot be used or is not needed in the application scenario, please remove the net cover.
2. Please pay attention to EMC evaluation during design. Improper system design may cause abnormal function of module.
3. When the boundary application of module limit parameters is involved, the FAE of our company can be contacted to confirm the relevant precautions.

9. Package size

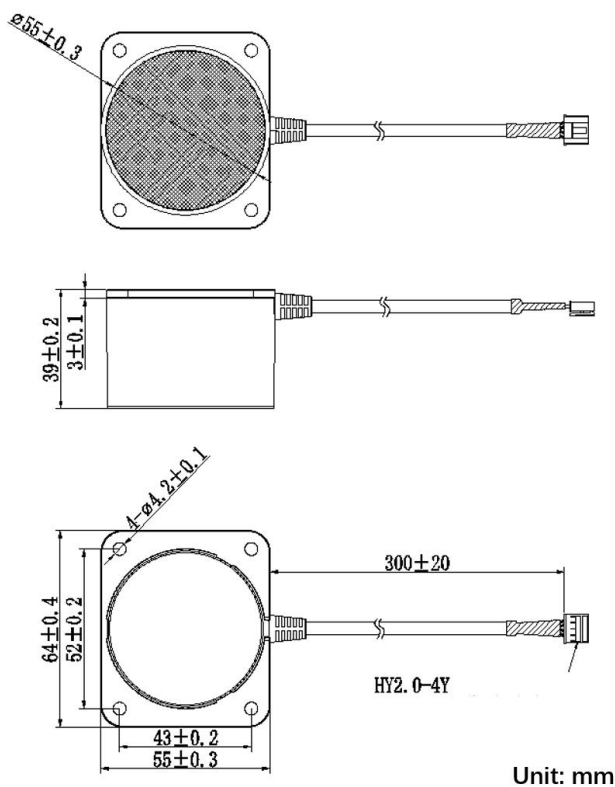

10. Packing specifications

By default, electrostatic bag and bubble bag packaging, no independent box.