



MONITOR ARM SIGMA

The Sigma Monitor Arm's effortless design enables installer to fit the arm in minutes with the swivel action allowing comfortable positioning by the end user.



FEATURES

- Top fix installation and through desk bolt fitting included
- Smooth Arm Insertion and Quick-Release VESA Plate enable easy installation
- Built-in Spring Tension Gauge: for perfect weight adjustments
- Spring-Assisted Mechanism: allows ease of movement up and down
- Cable management/allen key holder
- Available colours



Screen size
17" - 32"



Tilt Range
+90° ~ -90°



Swivel Range
+90° ~ -90°



Screen Rotation
+90° ~ -90°



VESA Compatible
75x75 & 100x100



Curved
Monitor



Cable
Management

MOUNTING INSTRUCTIONS

STEP 1



STEP 2



STEP 3





MONITOR ARM SIGMA

SPECIFICATIONS

Product Category:	Mechanical Spring Monitor Arm
Rank:	Premium
Material:	Aluminium, Plastic, Steel
Surface Finish:	Powder Coated
Color:	Matt Black and Matt White
Box dimensions:	115x561x520mm for single and 1044x129x532 for double
Fit Screen size:	17"-32"
Fit Curved Monitor:	Yes
Weight Capacity (per screen):	0-8kg
VESA Compatible:	75x75, 100x100
Tilt Range:	+90° ~ -90°
Swivel Range:	+90° ~ -90°
Screen Rotation:	+90° ~ -90°
Arm Full Extension:	467mm
Installation:	Clamp, Grommet
Suggested Desktop Thickness:	Clamp: 10~50mm; Grommet 10~50mm
Quick Release VESA Plate:	Yes
Cable Management:	Yes



Available as single and double

DIMENSIONS

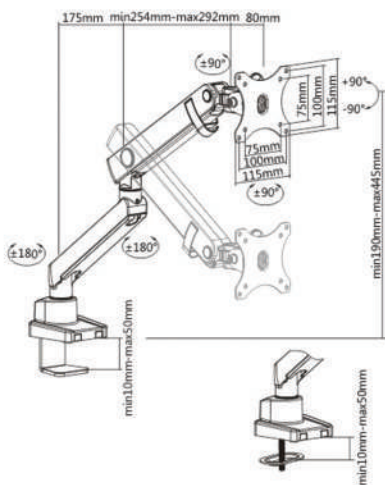

SINGLE

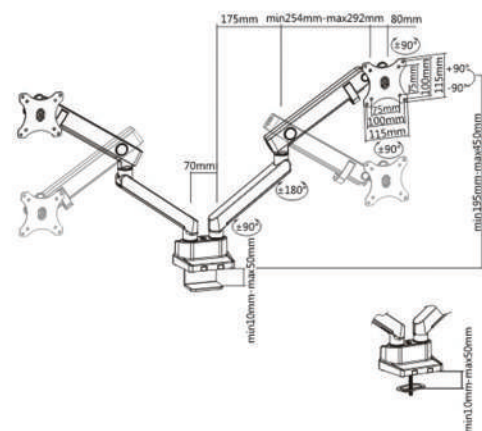

DOUBLE

