

Kite

MATERIALS:

1 yard of Loop (91 cm)
 2 wooden dowels
 24 in (60 cm) and 20 in (50 cm)
 Double sided carpet tape
 String

TOOLS:

Scissors
 Utility knife
 Sewing needle

DIFFICULTY: Hard

TIME: 1 - 2 hours

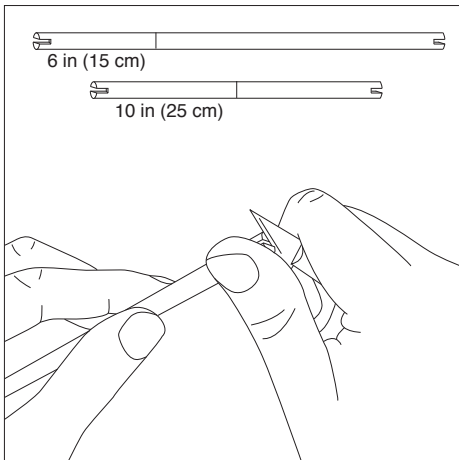

STEP 1 Mark the 24 in (60 cm) dowel 6 in (15 cm) from the end and the 20 in (50 cm) dowel 10 in (25 cm) from the end. CAREFULLY cut notches in the ends of the dowels.

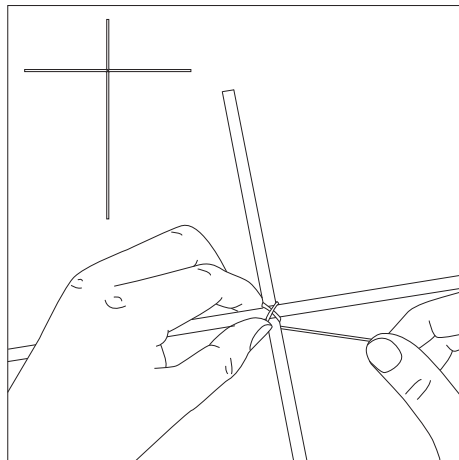

STEP 2 Cris-cross the dowels at the markings you made earlier and wrap the string around them in an X pattern to secure them. The notches should be parallel to the ground.

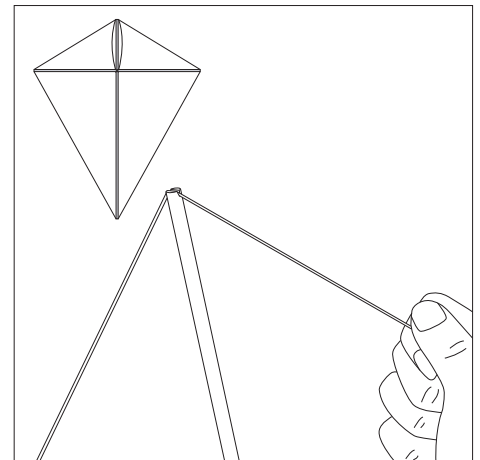

STEP 3 Thread your string through the notches to create a diamond shape. Wrap it around twice making sure to keep the string tight. Bring the end back down to the center to secure.

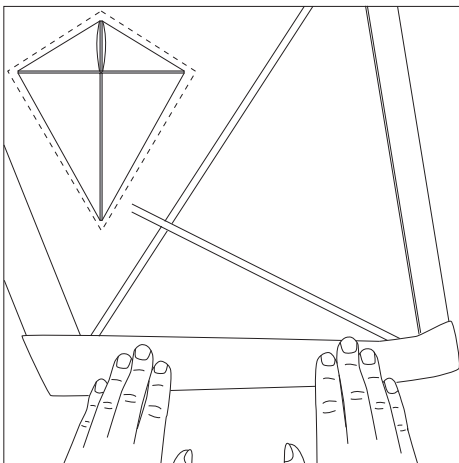

STEP 4 Lay the frame on top of Loop. Cut the material so that it is 2 in (5 cm) larger than the frame. Fold the edges of Loop over the frame and secure with carpet tape. Fold the corners in and reinforce them with tape.

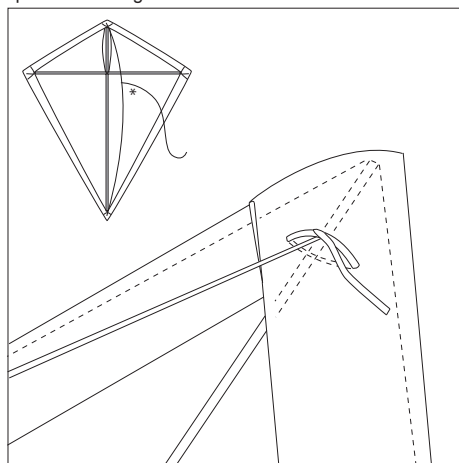

STEP 5 Make holes using a needle to secure a 24 in (60 cm) piece of string from the top corner to the bottom. Tie the remainder of your string to this line (this will be your flying string)*.

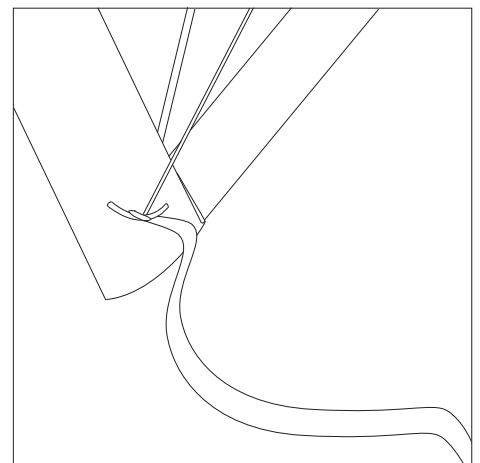

STEP 6 You can use your scraps to tie to a string for a tail. Attach your tail and fly.

Send us the scraps left over at the end of your project.

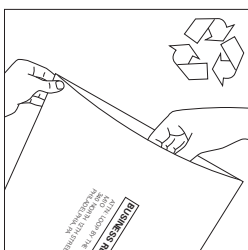

RECYCLING

Loop can be recycled and used to make plastic lumber for decks and other weather resistant, outdoor products. When your project is no longer needed please use the prepaid recycling envelope to send Loop back to us.

Misplaced your recycling envelope?
 Please write to: info@mioculture.com or call us at: 215-925-9359

To order more Loop go to www.mioculture.com