



Fridge Freezer

T65555FFM2IN/WH/BL



INSTRUCTIONS:

Please read and keep safe for future use.

INSTALLATION AND USER

Features.....	3
Transportation instructions.....	4
Introduction & safety warnings.....	5
Electrical Requirements/Installation	6
Food Storage	7
Defrosting/Arrangement of Food	9
Temperature Control	10
Cleaning and Care.....	11
Top Tips	12
Problem solving	14
Technical data/Health & Safety	16

Disposal/Warranty Information.....18

Customer Care

..... 20

Features

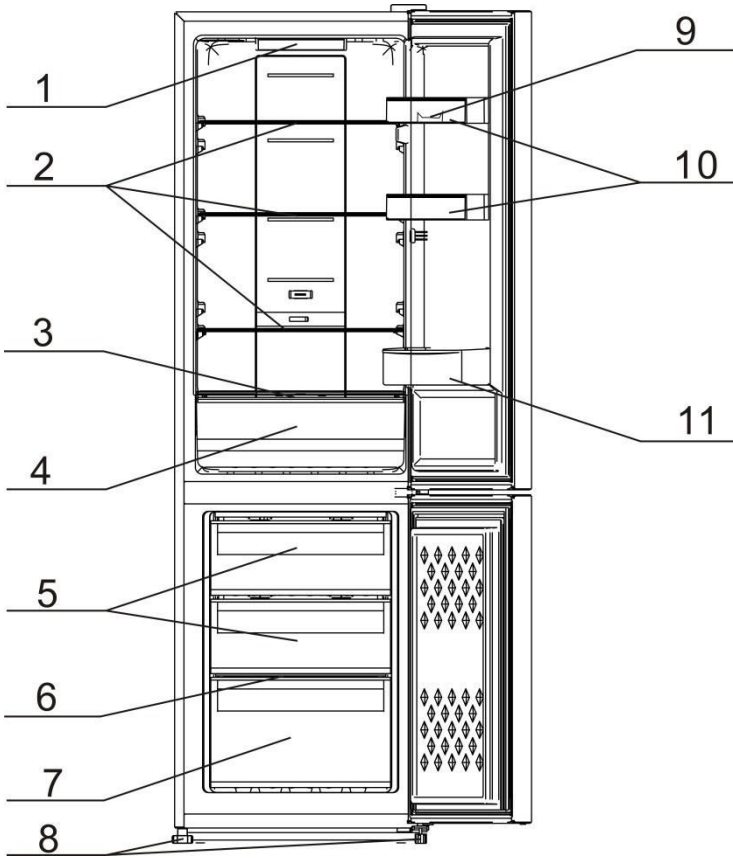

- | | |
|--------------------------|-------------------------|
| 1. Lamp Box Assembly | 7. Freezer Drawer |
| 2. Glass Shelf | 8. Adjustable Foot |
| 3. Crisper Cover | 9. Egg Tray |
| 4. Salad Crisper | 10. Bottle Rack (Upper) |
| 5. Upper Freezer Drawer | 11. Bottle Rack (Lower) |
| 6. Glass Shelf (Freezer) | |

Transportation of your

- When transporting, never tilt to more than 45 degrees
- The appliance should be transported only in a vertical upright position
- The packaging as supplied must be intact during transportation
- If during the course of transport the appliance has to be transported horizontally, it must only be laid on its left hand side when standing in front of the appliance. After bringing it to the upright position, it must not be operated for at least 4 hours to allow the system to settle. The manufacturer will not be held responsible if these instructions are disregarded.
- The appliance must be protected against rain and moisture
- When positioning your appliance take care not to damage your flooring, kitchen furniture, related parts and doors, pipes, wall coverings etc.
- Do not move the appliance by pulling by the door
- Hold the base and lift the refrigerator carefully
- Never hold the door handle as support
- Never place the refrigerator upside down or lie it down
- Move refrigerator by using its two hind roller feet as an axis and then tilting it slightly to move

Before First Use

IMPORTANT: Do NOT connect your appliance to the electricity supply until all packing and transit protectors have been removed.

- Leave to stand for at least 4 hours before switching on to allow compressor oil to settle if transported horizontally, if the appliance is switched off at any time, wait 30 minutes before switching back on to allow the coolant fluid to settle
- If you are discarding an old refrigerator with a lock or latch fitted to the door, disable the lock/latch, ensure that it is left in a safe condition to prevent the entrapment of young children
- This fridge/freezer must only be used for its intended purpose i.e. the storing and freezing of edible foodstuff

- Do not dispose of the appliance on a fire
- Take care not to damage the cooling circuit, if damaged immediately ventilate the room where the appliance is situated
- This appliance should not be used in an unheated, cold room i.e. garage, conservatory, annex, shed, out-house etc.
- Ensure that the plug remains readily accessible
- Failure to observe these instructions may invalidate your right to free service during the guarantee period
- We recommend a separate switch be used to ensure easy switch on/off
- Children should be supervised to ensure that they do not play with the appliance
- This appliance is intended to be used in a household environment

IMPORTANT WARNINGS:

Keep ventilation openings in the appliance enclosure and the built-in structure clear of obstruction.

Make sure that mains cable is not caught under the appliance during and after carrying / moving the appliance, to avoid the mains cable becoming cut or damaged.

Care must be taken while cleaning / carrying the appliance to avoid Touching the bottom of the condenser metal wires at the back of the Appliance as you may injure your fingers and hands.

Make sure that mains cable is not caught under the appliance During and after carrying / moving the appliance, to avoid the mains Cable becoming cut or damaged.

Electrical Requirements

Before you insert the plug into the wall socket make sure that the voltage and The frequency shown in the rating plate inside the appliance corresponds to

Your electricity supply. We recommend that this appliance is connected to the mains supply via a suitable switched and fused socket in a readily accessible position.

Should the mains lead of the appliance become damaged or should it need replacing at any time, it must be replaced by a special purpose made mains lead which can only be obtained from Shomar Ltd.

WARNING! THIS APPLIANCE MUST BE EARTHED

If the fitted plug is not suitable for your socket, then the plug should be removed and an appropriate plug fitted. Destroy the old plug which is cut off as a plug with bared cord could cause a shock hazard if inserted into a socket. The plug on this appliance incorporates a 13 A fuse. Should the fuse need to be changed a fuse of the same rating must be used. Ensure that the fuse cover is refitted.

Installation Instructions

1. Install the refrigerator on a flat surface in order to prevent vibration and noise.
2. The cord should be secured behind the appliance to avoid injury
3. Choose a dry well-ventilated place
4. Minimum space in the room where the refrigerator is being installed is 10 cubic metres.
5. Choose a location where there is no heat source. Keep the refrigerator away from direct sunlight, oven etc.
6. Do not place the appliance near cookers, radiators or in direct sunlight as this will cause your appliance to work harder.
7. Don't install this appliance in a wall recess or into fitted cabinets.
8. Allow a gap of 3.5" between the back grille and the wall.
9. Allow a gap of 2 cm either side of the unit.

10. To ensure that your appliance is level adjust the levelling feet at the front by turning them

Before you start using the refrigerator check that:

1. The interior is dry and air can circulate freely at the rear of the cabinet.
2. Clean the interior as recommended under "CLEANING AND CARE."
3. Insert the plug into the wall socket and switch on the electricity supply.
4. You will hear a noise as the compressor starts up. The liquid and gases sealed within the refrigeration system may also give rise to noise, whether the compressor is running or not which is quite normal.
5. Front edges of the cabinet may feel warm. This is normal.
6. Do not load the appliance immediately it is switched on. Wait until the Correct storage temperature has been reached. We recommend that You check the temperature with an accurate thermometer or wait 24 hours.

Food Storage

How to Use the Refrigerator Compartment:

- Cooked /fresh foods may be stored in your refrigerator. Hot foods must first be allowed to reach room temperature before storage
- Eggs and Bottle's should be stored on the shelves provided in the door
- Meat and fish should be covered to prevent loss of moisture and odours, wrap such foods in aluminium foil or polythene or store in an airtight container
- It is advisable to store cooked food on top shelves and fresh food on the lower shelves to prevent cross contamination

How to Use the Freezer Compartment:

- Pre-packed commercially frozen food should be stored in accordance with the frozen food manufacturer's instructions for a  frozen food storage compartment

- To ensure that the high quality achieved by the frozen food manufacturer and the food retailer is maintained, the following should be observed:
 - Put packets in the freezer as quickly as possible after purchase.
 - Ensure that contents are labelled and dated.
 - Do not exceed "Use By" or "Best Before" dates on the packaging
 - If there is a power failure do not open the door. Frozen food should not be affected if the failure lasts for less than 14 hrs. If the failure is longer, then the food should be checked and either eaten immediately or cooked and then refrozen

Freezing Fresh Food:

- Do not freeze too large a quantity at any one time. The quality of the food is best-preserved when it is frozen right through as quickly as possible
- Do not exceed the freezing capacity of your appliance in 24 h which is 4 kg (9 lb)
- Placing warm food into the freezer compartment causes the refrigeration compressor to operate continuously until the food is frozen solid. This can temporarily lead to excessive cooling of the refrigeration compartment.

Defrosting

This appliance defrosts automatically.

WARNINGS!

The fan inside the freezer compartment circulates cold air.

Never insert any object through the guard.

Do not allow children to play with the freezer fan.

Never store products that contain inflammable propellant gas (eg dispensers, spray cans etc.) or explosive substances.

Don't cover the shelves with any protective materials, which may obstruct air circulation.

Do not allow children to play with the appliance or tamper with the controls.

Do not obstruct the freezer fan guard.

ARRANGEMENT OF FOOD IN THE FRIDGE/FREEZER

The following guidelines and recommendations are suggested to obtain the Best results:

1. The fridge compartment is for the short term storage of fresh food and drinks.
2. The freezer compartment is rated and suitable for the freezing and storage of pre frozen food. The recommendation for storage as stated on the food packaging should be observed at all times.
3. Cooked dishes must be stored in airtight covered containers.
4. Fresh wrapped produce can be placed on the shelf. Fresh fruit and vegetables should be cleaned and stored in the crisper bins.
5. Bottles can be placed in the door section.
6. To store raw meat, wrap in polythene bags and place on the lowest shelf. Do not allow to come into contact with cooked food to avoid contamination. For safety, only store raw meat for two to three days.
7. Keep the food packed, wrapped or covered. Allow hot food and beverages to cool before placing them in the fridge. Do not store explosive substances.
8. High proof alcohol must be stored upright in sealed containers.
9. Left over canned food should not be stored in the can.
10. Fizzy drinks should not be frozen and products such as flavoured water ices should not be consumed too cold.
11. Some fruit and vegetables suffer damage if kept at too low a temperature.
12. Place chilled cooked food and similar food near the rear of the fridge inner liner where the cold wall is located.

13. Shelves, racks, crisper bins, drawers are all removable.
14. Do not leave frozen food at room temperature to thaw; the best way to defrost food is to put it in the fridge to thaw slowly.
15. For hygiene reasons, always wrap food using a suitable packaging material before storing in your appliance to avoid contact with the appliance surface.

Temperature Control

Control Panel

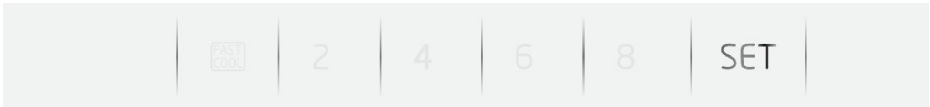

Volume Control



1. The display panel is located at the top of the refrigerator compartment and it controls the temperature
2. To allow for seasonal temperature change, set temperature to between 4 and 6 in spring and autumn with air volume control in the middle position. In the Summer adjust temperature to level 2 with the air volume control in a minimum position
3. To quickly chill food select the “Fast Cool” function
4. Increasing the air volume control lowers the temperature and vice versa.

When the appliance is switched on for the first time, the setting knob should be adjusted so that after 24 hours, the average fridge temperature is no

higher than +5 degrees Celsius. Some sections of the fridge may be cooler or warmer (such as the salad crisper and the top part of the cabinet. The temperature of the freezer compartment should be should be between -18°C and -25°C.

Cleaning and Care

- We recommend that you switch off the appliance at the socket outlet and pull out the mains plug before cleaning
- Never use any sharp abrasive instrument, soap, household cleaner, detergent and wax polish for cleaning
- Use lukewarm water to clean the cabinet of the appliance and wipe it dry
- Wipe the inside and outside of refrigerator with a damp soft cloth, a soft cloth with a mild detergent may also be used if required
- The grille of the condenser at the back the adjacent components can be vacuumed using a soft brush attachment.
- If the appliance is not going to be used for a long period of time unplug the appliance, remove all food, clean it and leave the door ajar
- Check door seals regularly to ensure they are clean and free from food particles

If you are going away on holiday or for any other reason, wish to leave the refrigerator idle for any period of time, proceed as follows:

- Disconnect the refrigerator from the electric power supply by removing the plug from the wall socket
- Remove all food
- Clean and dry the inside as instructed in the directions above for cleaning
- Leave the doors open to prevent any unpleasant smells from building up while the refrigerator is not used

Top Tips

- Clean your appliance regularly
- Keep raw meat and poultry below cooked food and dairy products
- Take off any unusable leaves on vegetables and wipe off any soil
- Wrap cheese firstly in greaseproof paper
- Wrap raw meat and poultry loosely in polythene or aluminium foil
- Wrap fish and offal in polythene bags
- Wrap food which have a strong odour in polythene bags, aluminium foil or place in an airtight container
- Wrap bread well to keep it fresh
- Keep food for as short a time as possible and adhere to "Best Before"/"Use by" etc. dates
- Store commercially frozen food in accordance with the instructions given on the packets
- Wrap frozen food when you buy it and put it in to the freezer as soon as possible
- Prepare fresh food for freezing in small portions to ensure rapid freezing
- Don't store bananas or melon in your fridge compartment
- Don't store poisonous or any dangerous substances in your appliance
- Don't consume food which has been stored for an excessive time in the fridge
- Don't leave the door open for long periods as this will make the appliance more costly to run and cause excessive ice formation
- Don't put hot food into the appliance
- Don't put liquid-filled bottles or sealed cans containing carbonated liquids into the freezer as they may burst
- Don't exceed the maximum freezing loads (4 kg in any 24 hours) when freezing fresh food
- Don't give children ice-cream and water ices direct from the freezer. The low temperature may cause 'freezer burns' on lips
- Don't freeze fizzy drinks
- Don't try to keep frozen food which has thawed, it should be eaten within 24 hours or cooked and refrozen

- Don't leave frozen food at room temperature to thaw; put it in the fridge to thaw slowly
- Keep electrical cable away from all sources of heat
- To maintain efficiency keep door opening to a minimum
- Keep ventilation openings clear of obstructions
- The appliance should only be used indoors and should not be exposed to rain or moisture
- Don't place heavy objects onto the refrigerator.

ENERGY SAVING TIPS

- Ensure your appliance is installed in a well ventilated area. If the ambient temperature is low (but in no case lower than 5 degrees C), then the energy saving will be more
- Ensure the time between buying chilled/frozen food and placing them in your appliance is kept at minimum, particularly in summer
- Do not leave the door of your appliance open longer than necessary and ensure they are closed properly after each opening

Problem Solving

Check the following:

- That the plug is inserted properly in the socket and that the power supply is on
- That the fuse has blown/circuit breaker has tripped/main distribution switch has been turned off
- That the temperature control has been set correctly
- That the plug is wired correctly if you have changed the fitted plug

If the appliance is still not operating after the above checks, please contact Shomar Ltd, see contact details.

Please ensure that the above checks have been made as a charge will be made if no fault is found.

Working Defects and Failures

Symptom: **Appliance will not work at all.**

Cause: The power supply plug is not inserted in the wall socket or the plug and the outlet is loose.

To test the supply socket a lamp or small electrical appliance may be used to check that the socket is working.

Symptom: **Noisy running.**

Cause: The appliance has not been properly levelled.

The refrigerator may be in contact with the wall or the accessories in the refrigerator may be placed in the wrong position.

Symptom: **Appliance does not cool sufficiently.**

Cause: Door has been opened too often, or for too long a time

There may be too much food in the refrigerator, possible incorrect temperature selection

Symptom: **Smell inside the appliance.**

Cause: Some of the food is not properly wrapped or covered.

The inside of the refrigerator needs cleaning; Liquids such as milk may have been spilled in the fridge.

The following are normal:

- Refrigerant running in pipes gives a gentle sound of water running in pipes
- In high humidity the outer surface of the refrigerator may be covered with condensation that should simply be wiped away
- The compressor and the rear condenser will become hot and should not be touched.

If after checking all of the above and the problem persists contact the Shomar Service Department.

Technical Data

Supplier's trademark	THOR
Supplier's model	T65555FFM2IN
Category of refrigerating appliance	Home appliance
Energy efficiency class	A+
Annual energy consumption(kWh)	255
Freezing storage volume & star rating	70 
Refrigerator storage volume	180
Identification of frost free compartments	/
Temperature rise time (power-cut safe time)	1128min
Freezing capacity	3.5kg/24h
Climate class	ST
Airborne noise emissions	42dB

* Annual energy consumption at **255** kwh/year,
based on test average temperature at 25°C

* Test voltage and Frequency : 230V±1% and 50Hz±1

Health & Safety

The use of any electrical appliance requires the following common sense safety rules. There is danger of injury or death and damage to the appliance.

Location

- This appliance is intended to be used in household and residential type environments. It is not suitable for use in shops, offices and other working environments
- Do not use outdoors or in a bathroom
- Do not place appliance on a highly polished wooden surface as damage may occur to the surface
- Do not place the appliance on or near a hot surface
- This appliance should not be used in an unheated, cold room i.e. Garage, conservatory, annex, shed, out-house etc.

Mains Cable

- Do not let the lead run across an open space
- Do not let the cable run across a cooker or hot area which may damage the cable
- The mains cable should reach from the socket to the base unit without straining the connections
- The power cord cannot be replaced

Personal Safety

- Avoid touching moving parts. Keep hands, hair and clothing and utensils away from the appliance and fan to prevent personal injury and/or damage to the appliance.
- To protect against the risk of electric shock ensure the electrical connections are kept dry
- This appliance is not intended for use by persons (including children) with reduced physical, sensory or mental capabilities

Children

- Children should be supervised to ensure that they do not play with this appliance
- Teach children to be aware of dangers in the kitchen
- Do not allow children to play with the appliance or tamper with the controls
- Children under the age of 8 should not use this appliance

Other Safety Considerations

- Do not operate any appliance with a damaged cord or plug or after the appliance malfunctions or has been damaged in any manner
- The use of attachments or tools not pertaining to this appliance may cause fire, electric shock or injury
- Do not use the appliance for anything other than its intended purpose
- Unplug from the outlet when not in use or unattended and before assembling, disassembling and cleaning
- Make sure the appliance is switched off before connecting to or disconnecting from the mains supply
- If the appliance is dropped or damaged in any manner, return the appliance to the nearest authorized dealer or after-sales service centre for examination, repair, electrical or mechanical adjustment

Disposal

Dispose of used electrical appliances in an environmentally friendly manner. This product should not be disposed with other household wastes throughout the EU. This Fridge Freezer bears the symbol for waste electrical and electronic equipment (WEEE). This means that this equipment must be handled in accordance with European Directive 2002/96/EC for recycling to minimise damage to the environment. Before disposing of the appliance, cut off the power cable plug and remove the door to avoid accidents.

Warranty

Registering Your 2 Year Guarantee

Your standard one year guarantee is extended for an additional 1 year when you register the product within 28 days of purchase with the supplier Shomar Ltd. If you do not register the product with Shomar Ltd within 28 days, your product is guaranteed for 1 year. To validate your 2 year guarantee register with us by completing the form attached and posting it to Shomar Ltd.

Please note that the 2 year guarantee is only available in Ireland.

Please refer to the one year guarantee for more information.

One Year Guarantee

It is important to retain the retailer's receipt as proof of purchase. Staple your receipt to this back cover for future reference.

Please quote the following information if the product develops a fault. These numbers can be found on the product.

Model no.

Serial no.

Subject to the exclusions set out below (see Exclusions), the faulty appliance will then be repaired or replaced. If for any reason, this item is replaced during the guarantee period, the guarantee on the new item will be calculated from original purchase date. Therefore it is vital to retain your original till receipt or invoice to indicate the date of initial purchase.

To qualify for the 1 year guarantee, the appliance must have been used according to the instructions supplied.

Exclusions

Shomar Ltd shall not be liable to replace or repair the goods under the terms of the guarantee where:

1. The fault has been caused or is attributable to accidental use, misuse, negligent use or used contrary to the manufacturer's recommendations or where the fault has been caused by power surges or damage caused in transit.
2. The appliance has been used on a voltage supply other than that stamped on the products.
3. Repairs have been attempted by persons other than our service staff.
4. The appliance has been used for hire purposes or non-domestic use.
5. The appliance is second hand.

This guarantee does not confer any rights other than those expressly set out above and does not cover any claims for consequential loss or damage. This guarantee is offered as an additional benefit and does not affect your statutory rights as a consumer. This guarantee is valid in Ireland and the UK only.

PowerPoint products are intended for household use only. See usage limitations in "safety instructions". Shomar Ltd has a policy of continuous improvement in product quality and design. The company, therefore reserves the right to change the specification of its models at any time.

Contact Details

The After Sales Division for PowerPoint Appliances is located at the offices of the Brand owner and Distributor –

Shomar Ltd, Unit 9 Western Industrial Estate, Dublin 12, Republic Of Ireland.

Helplines (office hours) & Spare Parts contact number is 01-450 9150 or email service@shomar.ie

