



---

# ***TENT FRAME REPAIR MANUAL OZTENT RV, RS, RX AND EYRE SERIES TENTS***

---

## **Purpose of the document**

The purpose of this document is to describe the correct procedures to repair and/or replace the tent frame for 'R' Series Oztents



<b>PURPOSE OF THE DOCUMENT</b>	<b>1</b>
<b>1. ICONS USED IN THE MANUAL</b>	<b>2</b>
<b>2. THE OZTENT 'R'SERIES FRAME</b>	<b>3</b>
2.1 Brief description	3
2.2 Complete parts list	3
2.3 Support	3
<b>3. REPAIRING AN OZTENT FRAME (R SERIES)</b>	<b>4</b>
3.1 General	4
3.2 Terminology	4
3.3 Replacing Broken parts:	6
3.3.1 Sliding Arm/Brace Extrusion with fittings - Part #7	6
3.3.2 Hinge - Part #2	7
3.3.3 Corner - Part #3	9
3.3.4 Foot Fitting - Part #4	10
3.3.5 Nut, Washer and Slider - Part #6	12
3.4 Removing Frame from Skin:	14
3.5 Replacing frame into Skin:	15

### 1. ICONS USED IN THE MANUAL

Throughout this document, the pictograms below are used to underline points or important notions.



Important information



Good to know - Tricks



Mandatory action

## 2. THE OZTENT 'R' SERIES FRAME



### 2.1 BRIEF DESCRIPTION

The Oztent 'R' Series Tent frame is very simple, but remarkably efficient in its design. It consists of three rectangular 'hoops', connected to two aluminium 'Feet'. The structure being erected by using four 'Sliding Arms' (Brace Extrusions) that are locked in an 'over-centre' position to ensure the structure stays upright. It is the core of the world famous 'Thirty Second Tent'.

It is unlikely that the frame will become damaged in normal operation. Sometimes, however, incidents involving storms, vehicles, trees and other unforeseen circumstances can result in breakages.

The purpose of this manual is to provide instructions as to how one can easily repair the tent frame.

### 2.2 COMPLETE PARTS LIST

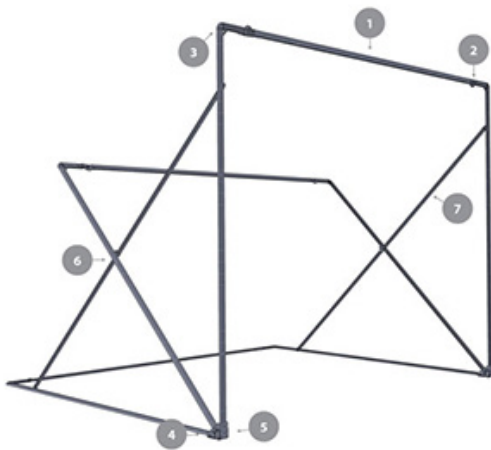

1. Main Extrusion (May Require Cutting) - OZME



4. Foot Fitting - OZFFP2



2. Hinge - OZHP2

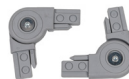

5. Foot - OZF



3. Corners - OZCP2



6. M8 Nut, Washer and Slider - OZS



7. Brace Extrusion with Fittings - OZSA



### 2.3 SUPPORT

For additional support please find the below contact points

#### Telephone

Australia Ph: 02 8706 5100

International Ph: +61 2 8706 5100

#### E-mail

service@oztent.com

## 3. REPAIRING AN OZTENT FRAME (R SERIES)



### 3.1 GENERAL

The Oztent Frame is relatively easy to easy to repair.

The key processes are as follows:

- Identify the parts that are broken (the above List, 2.2, allows for easy identification).
- Read the instructions below to ensure that you understand the repair process.
- Obtain replacement parts as required (refer 2.3 above).
- Determine whether the part you are replacing needs the frame to be removed from the tent skin (refer 3.4 below).
- Arrange a work area that allows you to set up and support the tent. This can be under a patio, in your garage, under trees or even just under your clothes line. The key is to be able to support the tent for all repairs, even if you do not need to remove the frame.

### 3.2 TERMINOLOGY

Apart from the names of the parts, there are a couple of terms used in this document that require clarification:

- **Vertical Frame segment:** This is the portion of the frame that forms the front wall of the tent when erected. It consists of several lengths of Main Extrusion (Part #1) that have been bolted to each Foot (Part #5). It also consists of two Corners (Part # 3) and two Hinges (Part # 2).

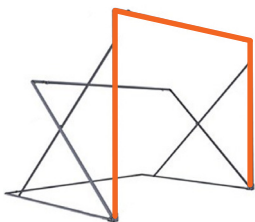

- **Horizontal Frame Segment:** This is the portion of the frame that forms the base of the tent. It consists of several lengths of Main Extrusion, two Corners, two Hinges and is connected to each Foot (Part # 5) by means of the Foot Fitting (Part #4) and a bolt and nut.

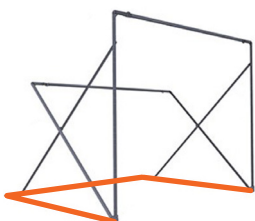

## 3. REPAIRING AN OZTENT FRAME (R SERIES)



- **Diagonal Frame Segment:** This is the portion of the frame that forms the diagonal support of the tent. It consists of several lengths of Main Extrusion, two Corners, two Hinges and is connected to each Foot (Part # 5) by means of the Foot Fitting (Part #4) and a bolt and nut. The side arms of this segment hold the Nut, Washer and Slider mechanism (Part #6).

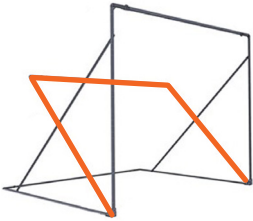

- **“A” Side:** This is the side of the tent that appears on the left hand side when one is facing the front of the tent from the outside. It is labelled, on the skin, with the letter “A”.
- **“B” Side:** This is the side of the tent that appears on the right hand side when one is facing the front of the tent from the outside. It is labelled, on the skin, with the letter “B”.

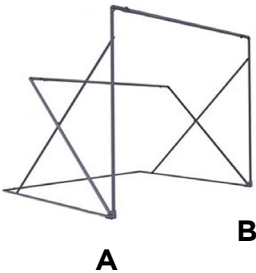



### 3.3 REPLACING BROKEN PARTS:

#### 3.3.1. SLIDING ARM/BRACE EXTRUSION WITH FITTINGS - PART #7

This is the part that connects the vertical and horizontal parts of the frame to the sliding mechanism located inside the diagonals. There are four Sliding Arms in the R Series Tent. They are all identical and will fit either side and both the upper and lower positions.

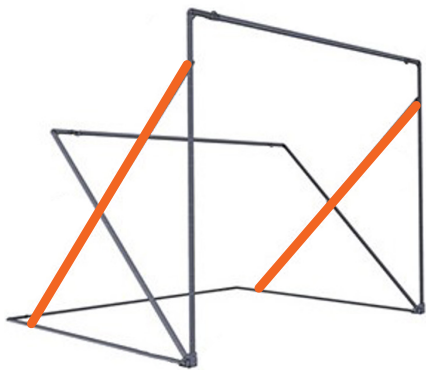

It is not necessary to remove the frame from the skin if the only part being replaced is the Sliding Arm.



It is important to support the Tent. For example, under a patio, in your garage, under trees or even just under your clothes line.

Once the Tent is erected and supported, remove the nut (M8) connecting the Sliding Arm to the Slider mechanism located on the Diagonal Frame Segment.

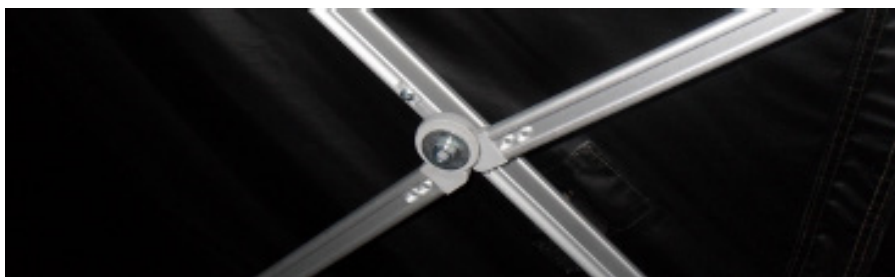

## 3. REPAIRING AN OZTENT FRAME (R SERIES)

Then remove the screw(s) holding the broken Sliding Arm to the horizontal or vertical frame segment (as required).

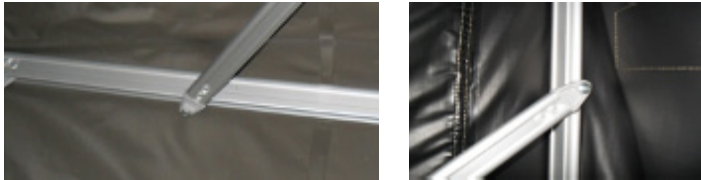

The Sliding Arm can then be easily removed and replaced with a new part.

To reattach the Sliding Arm, screw one end onto the horizontal or vertical frame segment before attaching the flat hinge portion of the Sliding Arm to the sliding mechanism located on the diagonal.



If your Oztent has rivets rather than screws connecting the Sliding Arm on the horizontal or vertical frame segment, please contact Oztent for further advice. Your Oztent is several years old and we wish to give you the best advice to ensure that you can enjoy your Oztent for many more years to come.

### 3.3.2. HINGE - PART #2

There are six hinges that form part of the Oztent frame. There are two each on the Vertical, Horizontal and Diagonal frame segments.

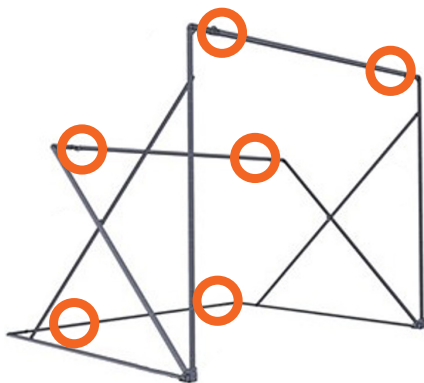

## 3. REPAIRING AN OZTENT FRAME (R SERIES)

If it is necessary to replace a hinge, it is critical that the frame is removed from the tent skin (refer 3.4 below).

If the hinge is broken, the easiest way to remove it is to use a sharp, fine hacksaw and cut the hinge at the point where the plastic of the hinge meets the aluminium extrusion. If the remaining plastic bits do not simply fall out, they should be pushed into the extrusion.



If it is desired to preserve the hinge fitting, it can be 'tapped out' using a screw driver/ chisel and a hammer. Note that you will need to fully secure the frame in bench vice or similar.



The replacement Hinge can be inserted into the extrusion and gently tapped into place using a rubber hammer or similar.







### 3.3.3. CORNER - PART #3

There are six corners that form part of the Oztent frame. There are two each on the Vertical, Horizontal and Diagonal frame segments.

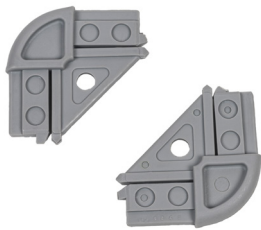
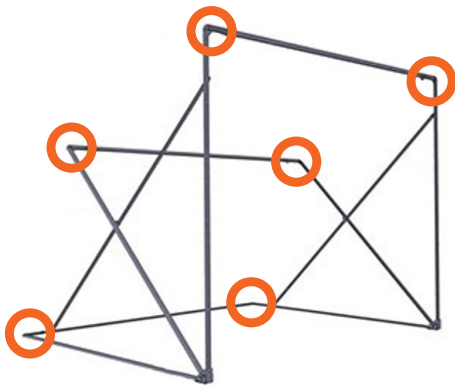

If it is necessary to replace a corner, it is critical that the frame is removed from the tent skin (refer 3.4 below).

The process for removing a corner is identical to the process for removing a hinge (refer above)

If the corner is broken, the easiest way to remove it is to use a sharp, fine hacksaw and cut the part at the point where the plastic of the corner meets the aluminium extrusion. If the remaining plastic bits do not simply fall out, they should be pushed into the extrusion.

If it is desired to preserve the Corner Fitting, it can be 'tapped out' using a screw driver/ chisel and a hammer. Note that you will need to fully secure the frame in bench vice or similar.

The replacement Corner Fitting can be inserted into the extrusion and gently tapped into place using a rubber hammer or similar.

## 3. REPAIRING AN OZTENT FRAME (R SERIES)

### 3.3.4. FOOT FITTING - PART #4

There are four Foot Fittings that form part of the Oztent frame. There are two each on the horizontal and diagonal frame segments. Note that the vertical frame segment does not have a Foot Fitting, as this frame segment is bolted directly onto the Foot (Part #5).

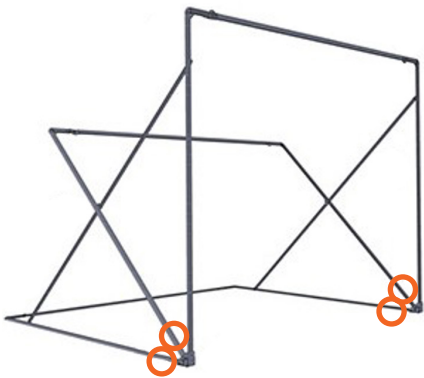

If it is necessary to replace a Foot Fitting, it is critical that the frame is removed from the tent skin (refer 3.4 below).

One then needs to remove the hinging bolt that is attached to the aluminium Foot (Part #5). This releases the frame segment to allow its removal from the rest of the frame.

The easiest way to remove the Foot Fitting from the aluminium extrusion is to use a sharp, fine toothed hacksaw and cut the part at the point where the plastic of the corner meets the aluminium extrusion. If the remaining plastic bits do not simply fall out, they should be pushed into the extrusion.

## **3. REPAIRING AN OZTENT FRAME (R SERIES)**

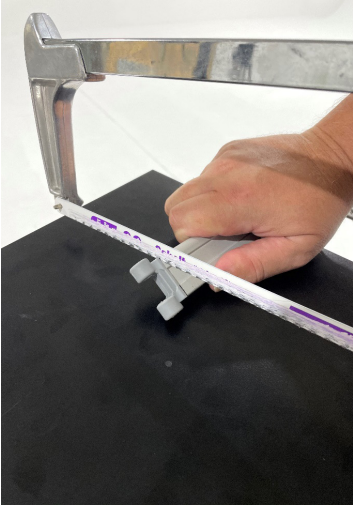

Alternatively, the Foot Fitting can be 'tapped out' using a screw driver/chisel and a hammer. Note that you will need to fully secure the frame in bench vice or similar.

The replacement Foot Fitting can be inserted into the extrusion and gently tapped into place using a rubber hammer or similar.





### 3.3.5. NUT, WASHER AND SLIDER - PART #6

There are two Nut, Washer and Slider Mechanisms (Part #6) on the Oztent Frame. One is located on the A side of the Frame (Diagonal Frame Segment) and the other on the B side. The mechanism consists of a “T” shaped Slider and a M8 nut and washer. The Sliders are located inside the Extrusion on each side of the Diagonal Frame segment.

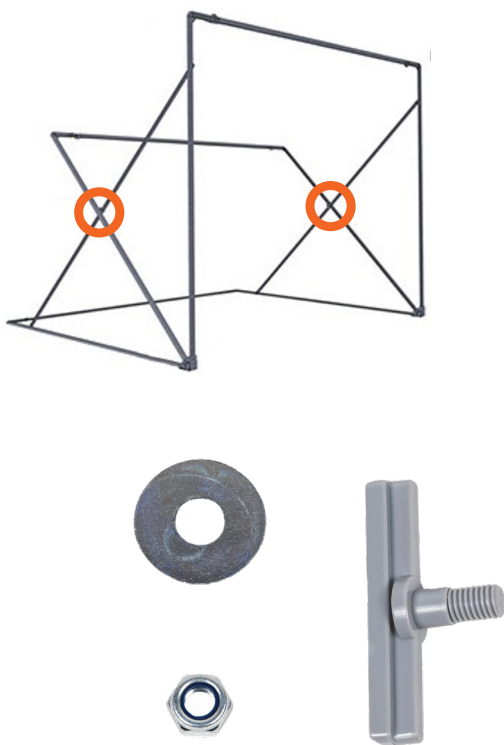

If it is necessary to replace the Slider, ensure that the frame is removed from the tent skin.

Disconnect both Sliding Arms (Brace extrusion Part #7) by removing the M8 Nuts and washers. The connecting screws on the upright and horizontal frame segments can be left in place for this process.

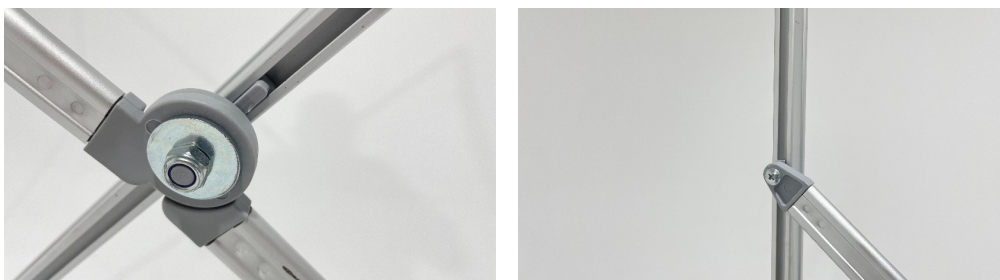

## 3. REPAIRING AN OZTENT FRAME (R SERIES)

Remove the diagonal frame segment by removing the nut and bolt attaching the diagonal frame segment to the tent foot as illustrated below.



It will be easier to work with the diagonal frame segment if it is completely removed from the rest of the frame. This simply means that the diagonal frame segment should be removed from both feet (A and B sides)



It will be necessary to remove the Foot Fitting from the end of the frame segment. This can be achieved by either cutting off or 'tapping out' the Foot Fitting as described above.

The broken Slider can be removed from the extrusion once the Foot Fitting has been removed. The replacement Slider can then be inserted into the extrusion and pushed to its correct position.

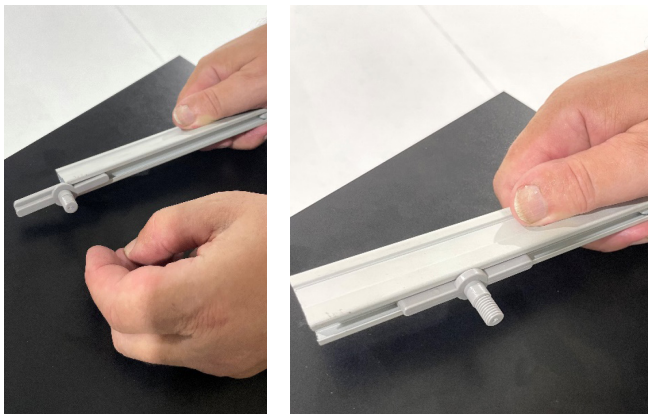

The Foot Fitting should now be reattached. The Diagonal Frame segment can then be refitted to the foot and the Sliding Arms/Brace Extrusions reconnected.

## 3. REPAIRING AN OZTENT FRAME (R SERIES)



### 3.4 REMOVING FRAME FROM SKIN:

Set up tent in a location where the skin can be supported, for example, under a patio, in your garage, under trees or even just under your clothes line. Once the Tent has been erected, use the attached guy ropes to suspend the tent skin.

Undo all Velcro fastenings inside the tent. There are Velcro attachments on all frame segments.

With the skin suspended, collapse the frame in the normal manner.



It often assists to bring the Feet in at about a 15-25 degree angle prior to collapsing the frame (while leaving the skin suspended). This makes it easier to collapse and remove the frame.





## 3. REPAIRING AN OZTENT FRAME (R SERIES)



### 3.5 REPLACING FRAME INTO SKIN:

To replace the frame into the skin, it is important that the skin is fully suspended as described above. Place the folded frame inside the tent skin. Ensure that the Vertical Frame segment is uppermost.

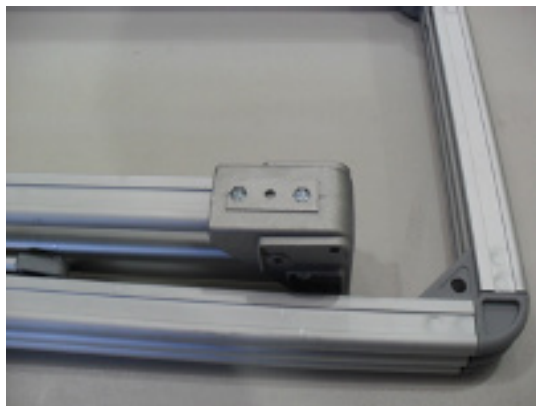

Note that the bolts holding the Vertical Frame segment to the Foot are clearly visible and facing up when placing the frame into the skin.

Gently bring out the B and A arms until they are about 15 - 25 degrees from their normal (fully opened) position.

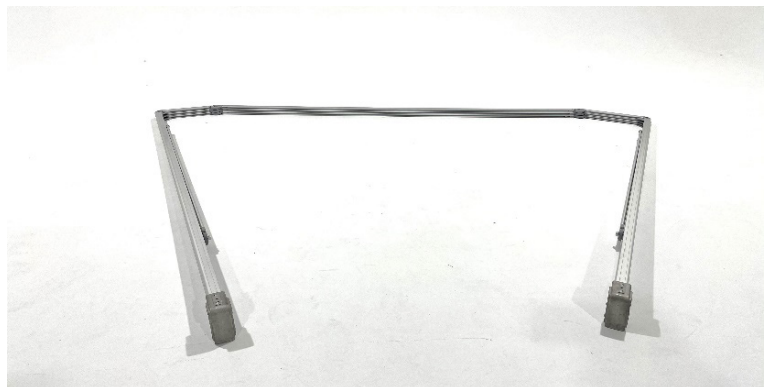
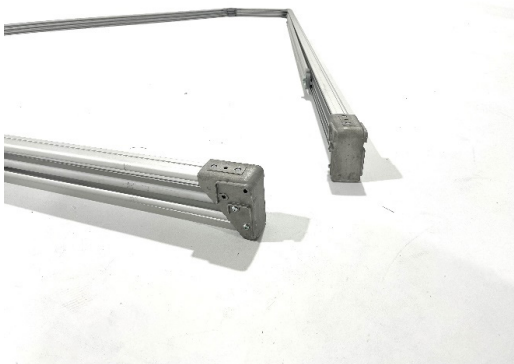

Gently lift up the frame within the tent skin. Once the frame is upright, slide up the Sliding Arms (brace extrusions) into position and push the tent feet into the front corners on each side.

Reattach all Velcro attachments to the frame.

**End of document**