

Read all instructions BEFORE assembly and USE of this product.
KEEP INSTRUCTIONS FOR FUTURE USE

Mika Micky

Bedside Sleeper

MM08

Instruction Manual

WARNING

Failure to follow these warnings and instructions could result in serious injury or death.

KEEP THIS BOOKLET HANDY FOR FUTURE REFERENCE

CONTENTS

WARNING	1-3
PARTS LIST	4
ASSEMBLY	5-8
CONVERT TO CO-SLEEPING POSITION	9-10
CLEAR AND MAINTENANCE	11-12

Need help?

Phone: 1-866 995 8668 (US toll free)

Mail: cs@mikamicky.com

www.mikamicky.com

WARNING!

The co-sleeping mode is **ONLY** possible with adult bed types that comply with all the conditions described in the following graphics. The adult beds unfit with the following graphics **CANNOT** be used.

Mattress, Boxsprings & Frame aligned

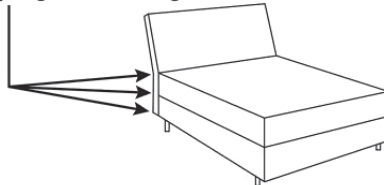

ACCEPTABLE BED FRAME IN-LINE

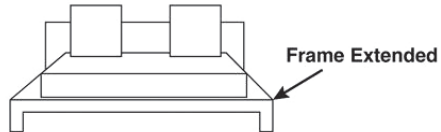

**UNACCEPTABLE BED,
MATTRESS, BOXSPRING & FRAME NOT IN-LINE**

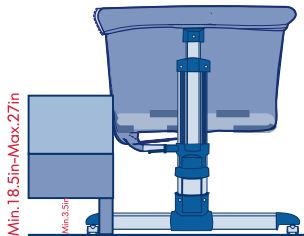

**ACCEPTABLE ADULT BED
CONDITIONS FOR
CO-SLEEPING MODE**

Make sure adult bed's bottom has at least **3.5in** high space for bedside sleeper's legs to slip into.

Read all instructions BEFORE assembly and USE of this product.

⚠ WARNING: Failure to follow these warnings and instructions could result in serious injury or death.

SUFFOCATION HAZARD: Discard all packing materials immediately after opening. Plastic bags and ties may cause suffocation or choking.

***FALL HAZARD** – To help prevent falls, do not use this product when infant begins to push up on hands and knees or has reached manufacturer's recommended maximum weight of 33 lbs, whichever comes first.

***SUFFOCATION HAZARD** – Infants have suffocated

*In gaps between extra padding and side of bassinet, and

*On soft bedding

*Use only the pad provided by manufacturer.

*Never add a pillow, comforter or another mattress for padding.

*If a sheet is used with the pad, use only the one provided by Mika Micky or specifically designed to fit the dimension of the bassinet mattress.

*To reduce the risk of SIDS, pediatricians recommend healthy infants be placed on their backs to sleep, unless otherwise advised by your physician.

*A bedside sleeper is designed to provide a sleeping area for an infant until he or she begins to push up on hands and knees or approximately 5 months of age. Move your child to another sleeping product when your child reaches this stage.

***Entrapment Hazard**—To prevent death from entrapment, bedside sleeper must be properly secured to adult bed using the attachment system.

–There must be NO more than 1/2 in. (13 mm) gap between bedside sleeper and adult bed.

–Check tightness before each use by pulling bedside sleeper in a direction away from adult bed.

-If gap exceeds 1/2 in. (13 mm), DO NOT use product. Do not fill the gap with pillows, blankets or other items that are suffocation hazards.

*Always read and follow assembly instructions for each product use mode (bedside sleeper, bassinet).

*Always use ALL required parts for each use mode.

Check instruction manual for a list of required parts.

Periodically check product for loose, damaged, or missing parts.

*The "L" hooks and straps assembly must always be used in bedside sleeper mode.

*Never use this product if there are any loose or missing fasteners, loose joints, broken parts, or torn mesh/fabric.

Check before assembly and periodically during use.

Contact Mika Micky for replacement parts. Never substitute parts.

*To avoid death from the infant's neck being caught on the lower locking bar on the side that is next to the adult bed, the lower locking bar must be NO HIGHER than the adult bed mattress.

*Never permit bedding from the adult bed to extend into the bedside sleeper.

*NEVER LEAVE your infant unattended in the Mika Micky bedside bassinet.

*Strings can cause strangulation! Never place items with a string around a child's neck such as hood strings or pacifier cords.

DO NOT suspend strings over the unit in any configuration or attach string to toys.

*NEVER LEAVE infant in product without the UPPER LOCKING BAR installed in the upper most position, unless securely attached to the adult bed.

*Always check to be sure that the upper locking bar and the lower locking bar are in their "locked position" before placing the infant in the Mika Micky bedside bassinet.

*NEVER use plastic shipping bags or other plastic film as mattress covers not sold and intended for that purpose. They can cause suffocation.

*Make sure all straps are secured and tight when used in the co-sleeping position. Tighten straps periodically.

*STRANGULATION/SUFFOCATION HAZARD: The top edge of the lower locking bar must be level with or below the top of the adult mattress when the bedside bassinet used as co-sleeping mode. The level of the bedside bassinet mattress must be a minimum of 4 inches below the top edge of the lowering bar. NEVER raise the level of the Mika Micky bedside bassinet mattress.

*NEVER USE the Mika Micky bedside bassinet in co-sleeping position without the “L” hooks attached and locked as shown. Failure to use this hooking system could result in serious injury or death to the infant.

Make sure all straps are secured and tight.

Check straps before each use.

*Failure to use this securing system will allow the bedside bassinet to move away from the adult bed and could result in the infant falling out of the bedside bassinet.

*STRANGULATION HAZARD: When “L” hooks and straps assembly are not in use, store in a safe place not accessible to children.

*DO NOT place product near a window where cords from blinds or drapes may strangle a child.

*Keep the bassinet away from stoves, heaters, campfires and other hazards.

*DO NOT allow children to climb or play on or under unit in any configuration.

*FALL HAZARD: Remove infant from the Mika Micky bedside bassinet before starting any conversions.

*Always make sure all top and bottom rails are securely locked, in all configurations, before putting an infant/child into the unit.

*Do Not remove warning labels.

WARNING

DO NOT use bedside sleeper if any parts are missing, damaged, or broken. Contact Mika Micky for replacement parts and instructional literature if needed. DO NOT substitute parts.

PARTS LIST

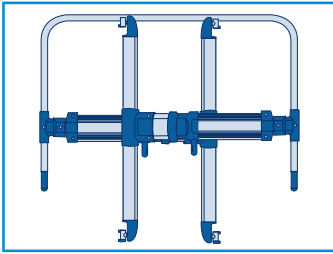

A. Main frame

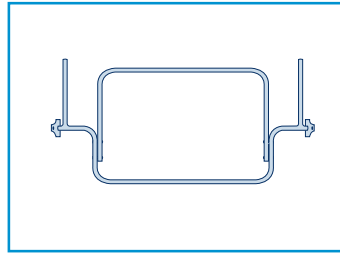

B. Support frame

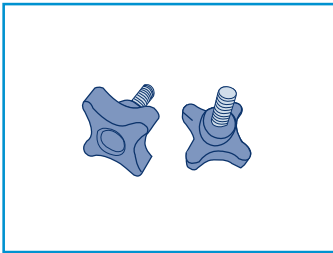

C. Screws for support frame

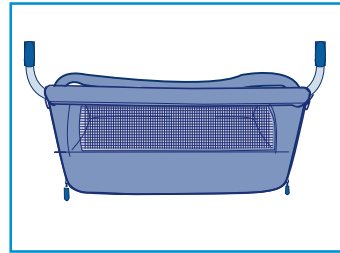

D. Upper locking bar with cover

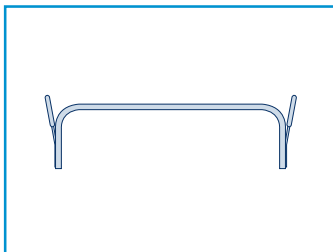

E. Lower locking bar

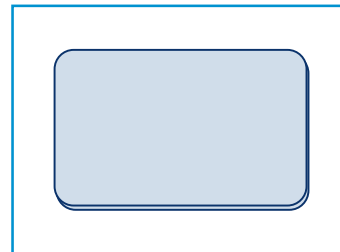

F. Mattress

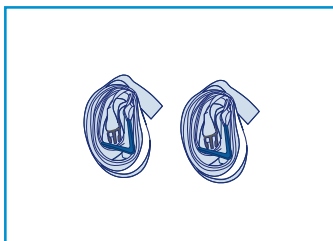

G. Straps with "L" hooks and buttons

ASSEMBLY

⚠️ WARNING Failure to follow these warnings and instructions could result in serious injury or death.

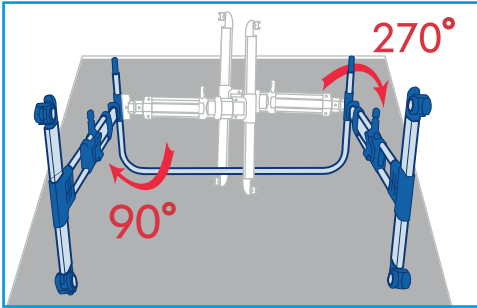

Step 1: Lay down main frame and open it.

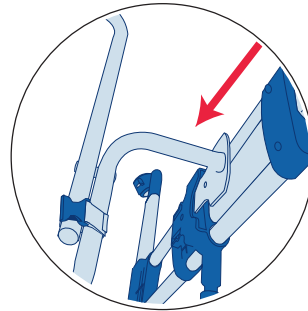
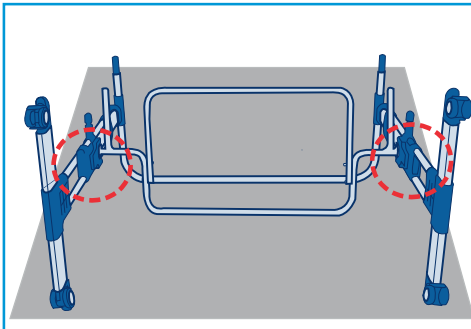

Step 2: INSERT support frame' s two sides into the slot on the middle of main frame legs.

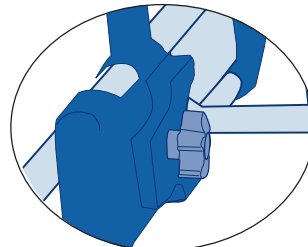
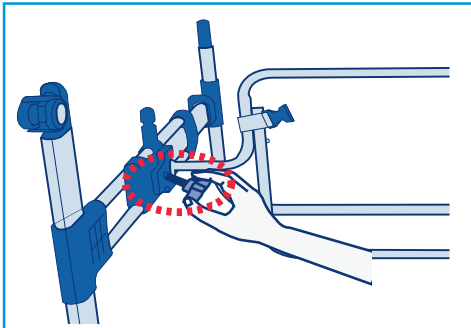

Step 3: Use screws to tighten step 2.

ASSEMBLY

⚠ WARNING Failure to follow these warnings and instructions could result in serious injury or death.

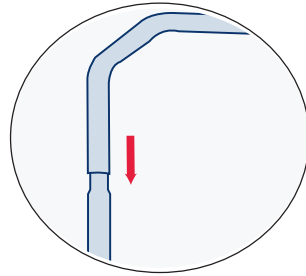
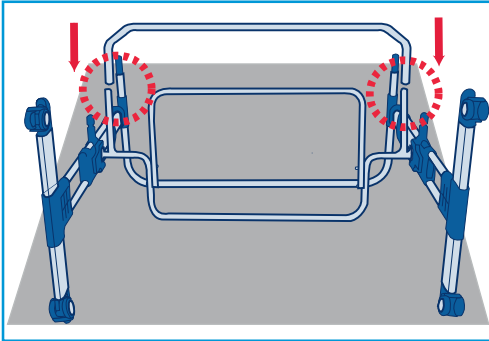

Step 4: Insert lower locking bar as picture shown.

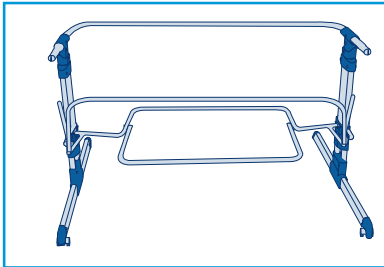

Step 5: After step 4, make the whole frame stand up.

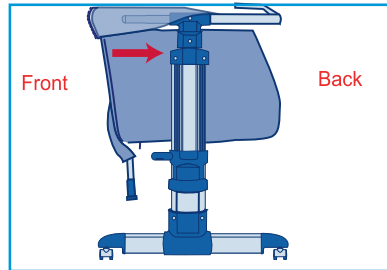

Step 6: Put part D on the frame and install the cover.

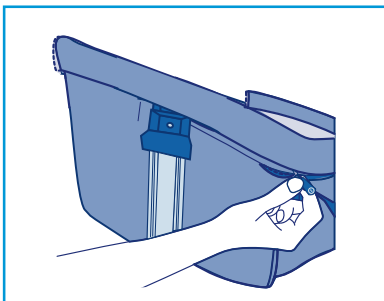

Step 7: Zip up the cover with the back frame.

ASSEMBLY

⚠ WARNING Failure to follow these warnings and instructions could result in serious injury or death.

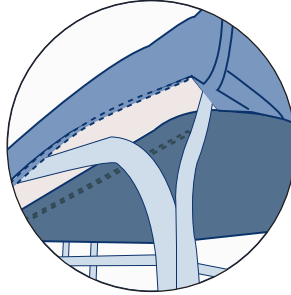
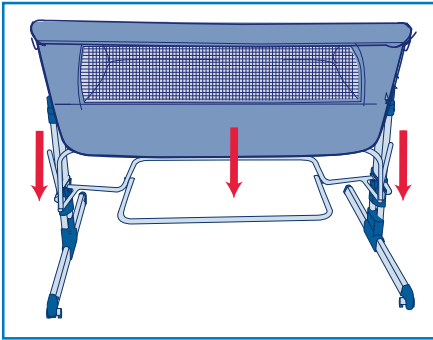

Step 8: Insert the lower locking bar into the cover.

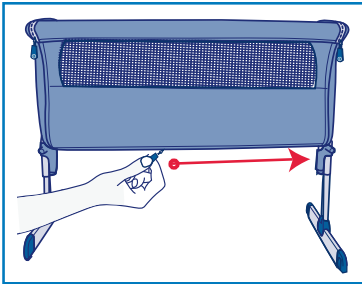

Step 9: Zip up the cover.

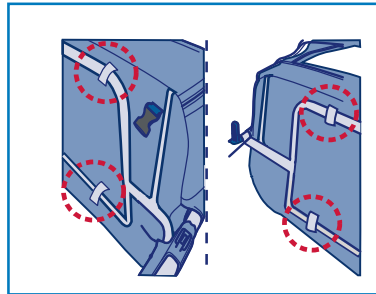

Step 10: Fasten the hook and loop (on the bottom of the cover) to the bottom frame as tight as possible.

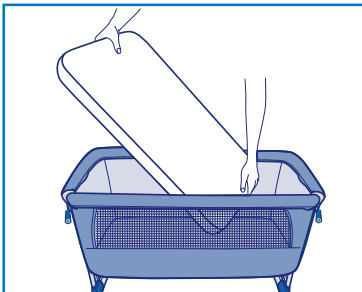

Step 11: Put the mattress on and make it flat.

ASSEMBLY

⚠️ WARNING Failure to follow these warnings and instructions could result in serious injury or death.

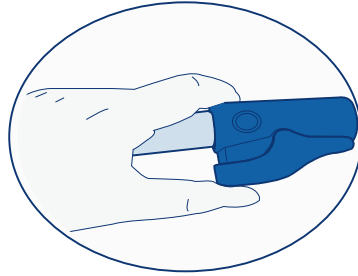
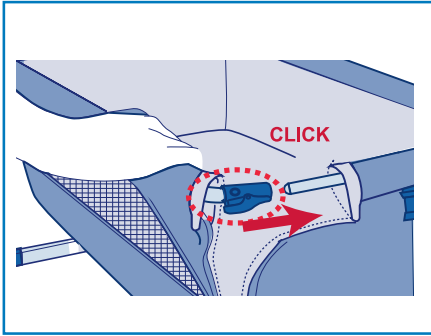

Step 12: Insert the upper locking bar into the frame, “click” means success.

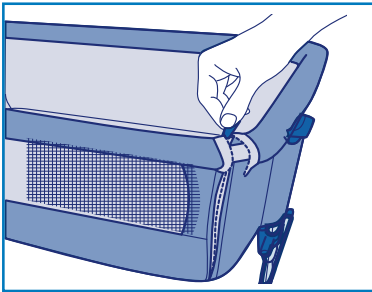

Step 13: Zip up the two sides.

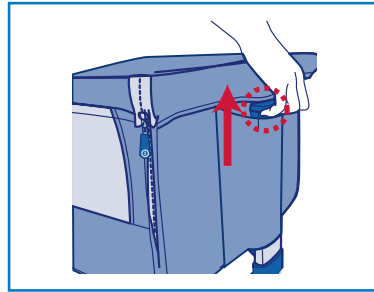

Step 14: Lift up the buttons on the two sides to adjust the height.

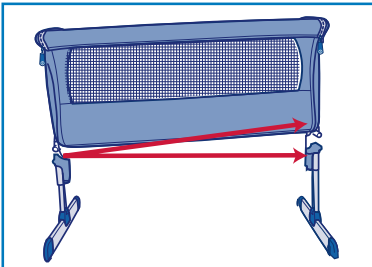

Adjust the crib to the proper height and make sure the mattress level.

⚠️ WARNING: Make sure all loops and buttons are secured and tight. Periodically check your product to make certain all loops and buttons are tightly secured. **DO NOT** expose lower locking bar when it is properly installed.

TO CONVERT TO CO-SLEEPING POSITION

⚠ FALLING HAZARD: Remove infant from the Mika Micky bedside bassinet before starting any conversions.

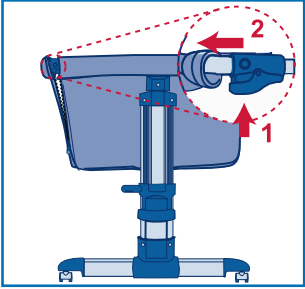

Step 1: Press the two sides buttons on the upper locking bar simultaneously to take out it.

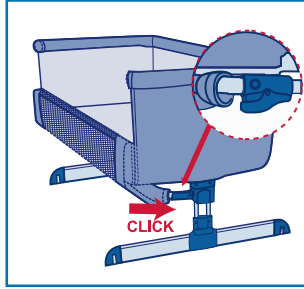

Step 2: Insert the upper locking bar into the place showed in the picture.

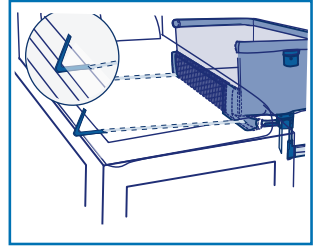

Step 3: Take out the straps, make the “L” hooks hook on the other side of the adult bed mattress and let the straps go through the bottom of the adult bed mattress.

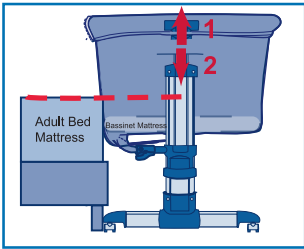

Step 4: Adjust the bassinet's height to fit the adult bed. The top edge of the lower locking bar must be level with or below the top of the adult mattress

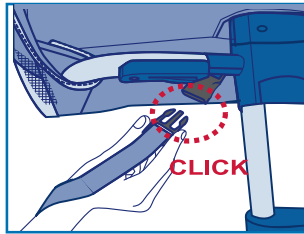

Step 5: Click the buttons of the straps into the buttons of the bottom of the bassinet as showed in the picture.

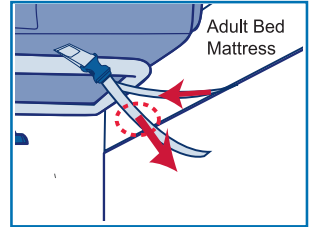

Step 6: Pull the ends of the straps to make the bassinet and the adult bed as close as possible.

⚠ WARNING: Check tightness before each use by pulling bedside sleeper in a direction away from adult bed. Make sure the gap is no more than 1/2 in. (13mm). If more than 1/2 in. (13mm), readjust strap to pull tighter.

It is recommended to make the strap shorter than the width of the mattress to ensure the bassinet is pressed securely against the parental bed, without any gaps. When bassinet is tight and ready to use, roll the excess strap up and secure it with elastic loop.

TO CONVERT TO CO-SLEEPING POSITION

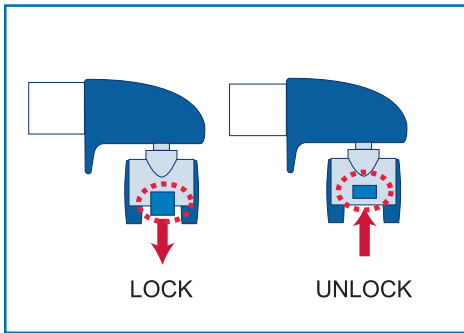

! WARNING:

Use the unlocked wheels ONLY when you want to move the bassinet. DO NOT put down the upper locking bar when the wheels are unlocked.

Step 7: Make sure the wheels are all locked.

! WARNING: STRANGULATION/SUFFOCATION HAZARD: The top edge of the lower locking bar must be level with or below the top of the adult mattress when the bedside bassinet used as co-sleeping position. The level of the bedside bassinet mattress must be a minimum of 4 inches below the top edge of the lower locking bar. NEVER raise the level of the bedside bassinet mattress.

! WARNING: NEVER USE a Mika Micky bedside bassinet in co-sleeping position without the “L” hooks attached and locked as shown. Failure to use this hooking system could result in serious injury or death to the infant. Make sure all straps are secured and tight. Check straps before each use .

! WARNING: Failure to use this securing system will allow the bedside bassinet to move away from the adult bed and could result in infant falling out of the bedside bassinet. NEVER leave infant unattended in the bedside bassinet.

! WARNING: STRANGULATION/CHOKING HAZARD: Do not allow excess strap (or any other loose object) to find it's way into the bedside bassinet. Do Not allow excess strap to lay loose on floor because someone may trip over it.

! WARNING: Make sure all straps are secured and tight. Periodically check your product to make certain all straps and buttons are tightened securely.

! WARNING: Make Sure Push Button on leg extension mechanism is secured for proper bed height.

! WARNING: During use, make sure that the parent's bed sheets, blankets etc. do not enter and cover the interior of the bassinet.

! WARNING: DO NOT expose the lower locking bar when it is properly installed.

Mattress, Boxsprings & Frame aligned

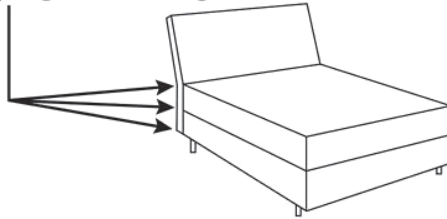

ACCEPTABLE BED FRAME IN-LINE

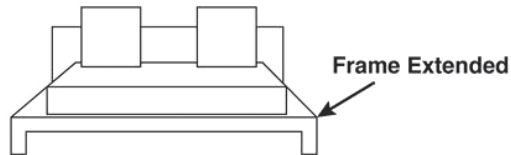

**UNACCEPTABLE BED,
MATTRESS, BOXSPRING & FRAME NOT IN-LINE**

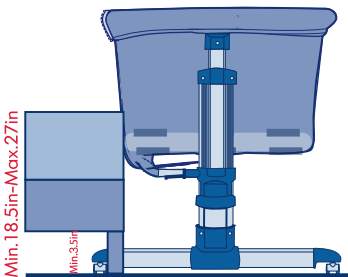

**ACCEPTABLE ADULT BED
CONDITIONS FOR
CO-SLEEPING MODE**

WARNING:

The bedside sleeper is designed for use only with adult beds that are between 18.5 and 27 inches from floor to top of adult mattress.

Cleaning:

Mattress: Wipe clean with a damp cloth. Air dry. Do not machine wash or use hot iron.

Mattress sheet: Machine wash, lukewarm water. Do not bleach. Air fluff dry. No heat.

Metal Frame: Wipe With soft damped cloth. Air dry.

Lining: Machine washable on lukewarm setting use delicate cycle. No chlorine bleach. Drip dry.

Maintenance:

Regularly check springlock to make sure they are securely in place. Wipe surface with a damp cloth or sponge using mild detergent water.

Ningbo Geyun Network Technology Co., Ltd. Room 6518,
No. 158, Changxing Road, Jiangbei District, Ningbo City,
315000 China

Tel: 1-866-995-8668 (US toll free)

Mail: cs@mikamicky.com

www.mikamicky.com

