



ASSEMBLY GUIDE
GUIDE DE MONTAGE
GUÍA DE MONTAJE

URBANA

12"X24"11 PLANTER

PLANTEUR 12"X24"X11"

JARDINERA 12"X24"X11"

VT17901

SLATE
ARDOISE
PIZARRA

2-PACK
PAQUET DE 2
2 PAQUETES

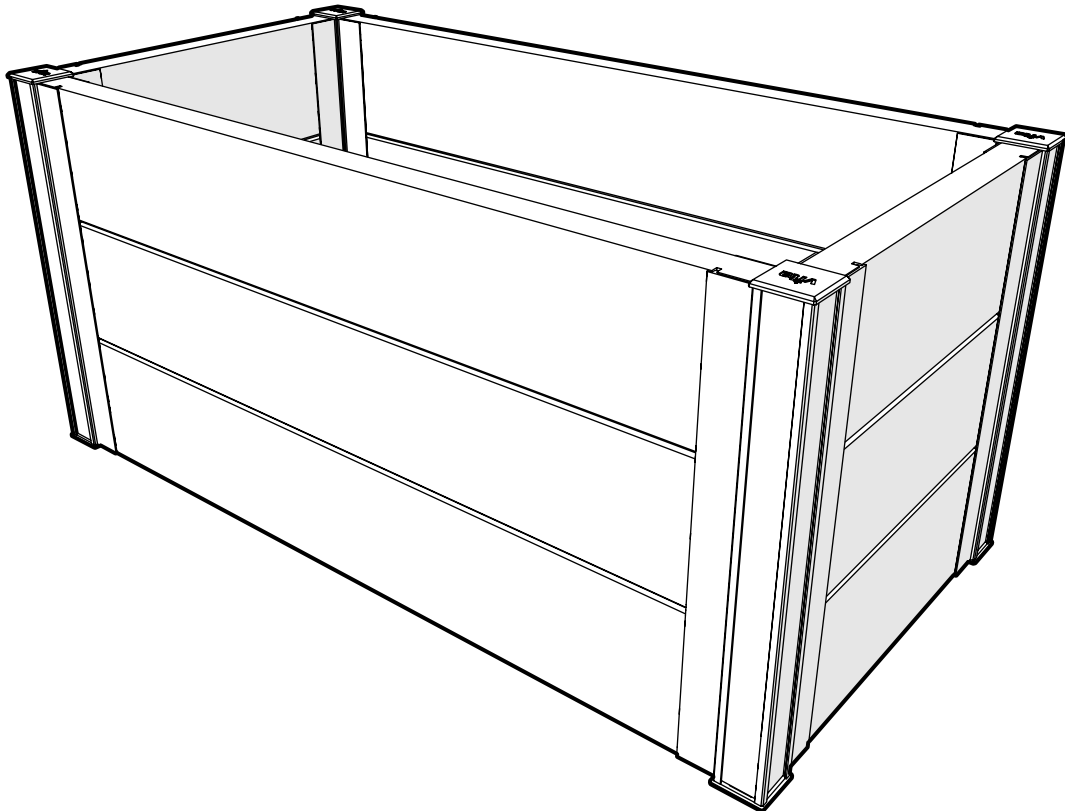

VER 1.9 10302020

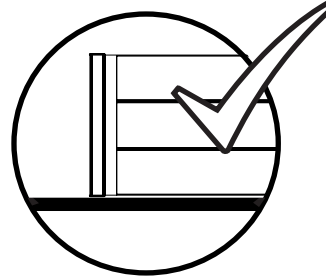
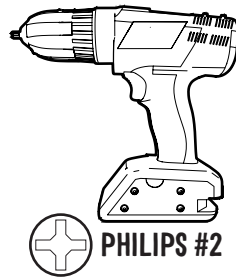
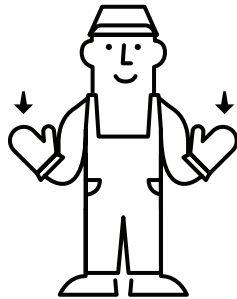
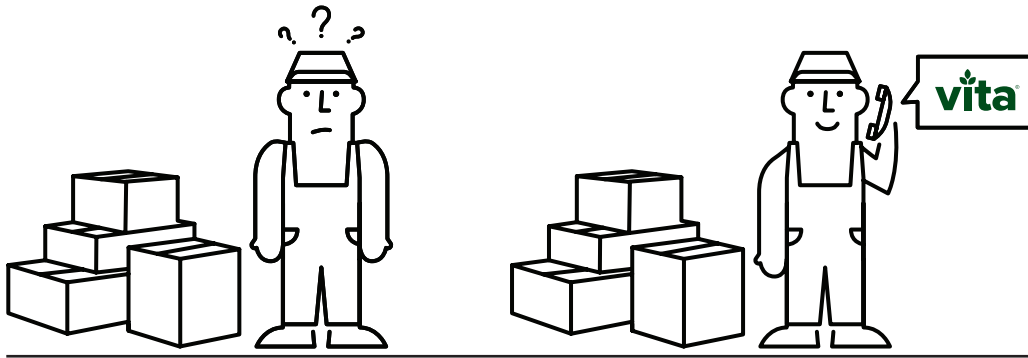

 1-800-282-9346



HELLO@WEAREVITA.COM



WWW.WEAREVITA.COM



8AM - 5PM EST



PARTS LIST

LISTE DES PIÈCES

LISTA DE PARTES

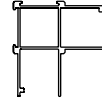
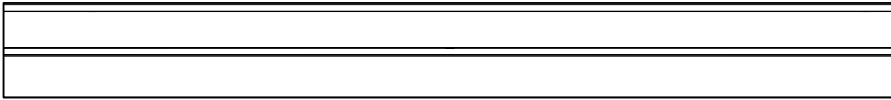

16132 - POST - PUBLIER - EXPONER - 11" (27.9 CM) - X8

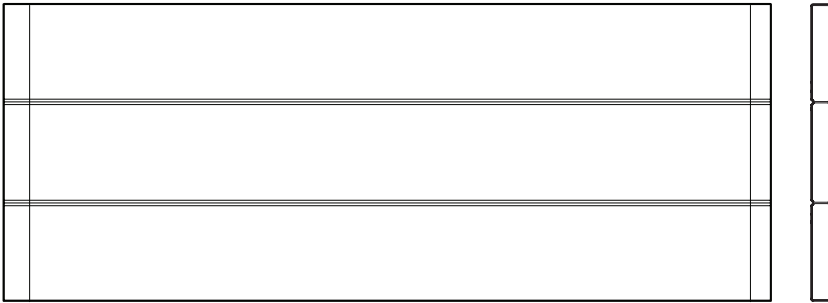

**16141 - SLATE - ARDOISE - PIZARRA
BOARD A - PLANCHE A - TABELRO A**
21 1/2" (54.6 CM) - **X4**

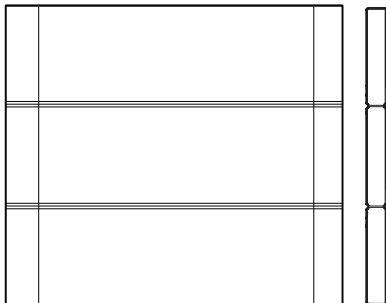

**16135 - SLATE- ARDOISE - PIZARRA
BOARD B - PLANCHE B - TABELRO B**
9 1/2" (24.1 CM) - **X4**

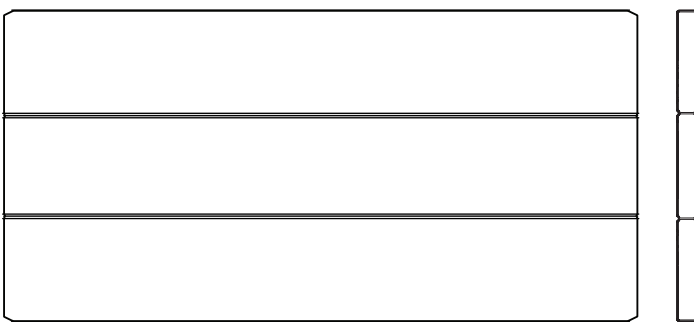

**16145 - SLATE SLATE - ARDOISE - PIZARRA
FLOOR BOARD - PLANCHE D'ÉTAGE - TABLERO DE PISO**
21 7/8" (55.5 CM) - **X2**

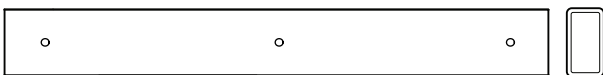

**16144 - SLATE - ARDOISE - PIZARRA
FLOOR BRACE - BRACE DE PLANCHER - BRACE DE PISO**
18 3/4" (47.7 CM) - **X4**

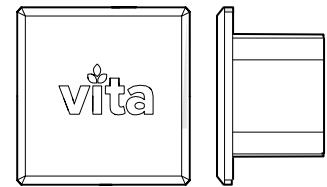
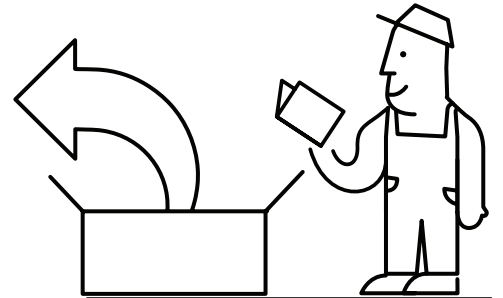

16325

POST CAP - ETE DE POTEAU - TAPON

1 1/4"x1 1/4" (3.2 CM x 3.2 CM)

X16

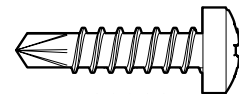

20066

SCREW A

VISSER A
TORNILLO A
5/8IN (1.6CM)

X16

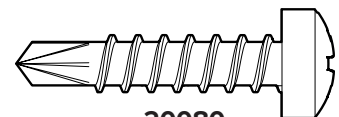

20080

SCREW B

VISSER B
TORNILLO B
1 1/4IN (3.2 CM)

X12

PRODUCT DIMENSIONS

DIMENSIONS DU PRODUIT

DIMENSIONES DEL PRODUCTO

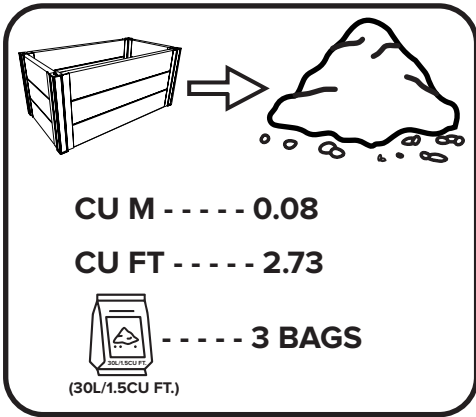

CU M ----- 0.08
CU FT ----- 2.73
3 BAGS
(30L/1.5CU FT.)

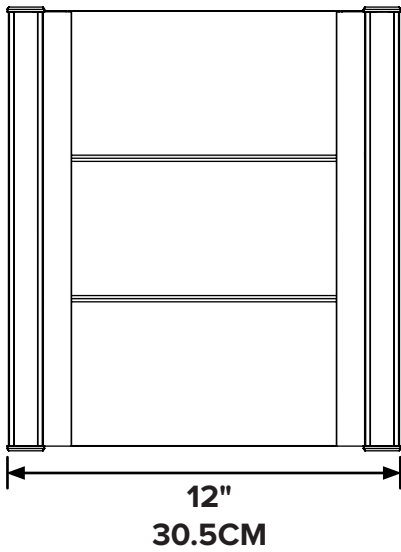
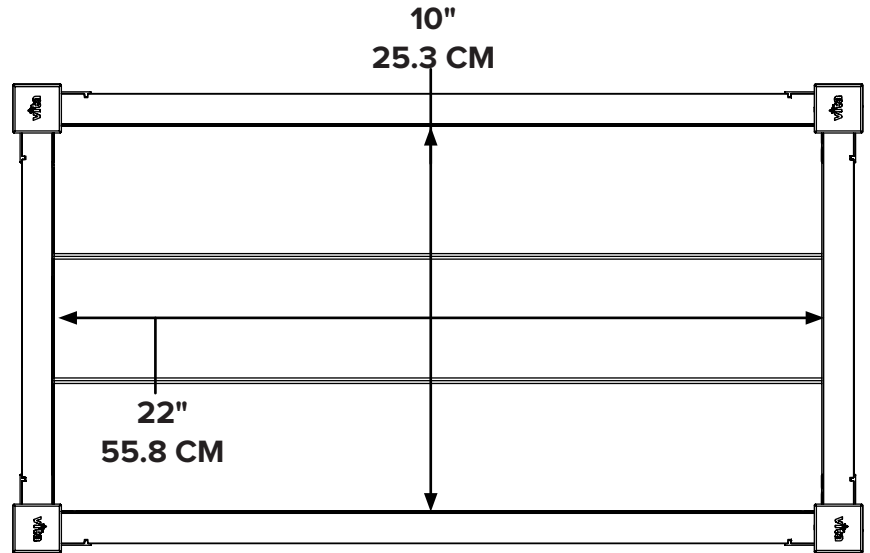

1

16135 - x2 (B)

16132 - x4

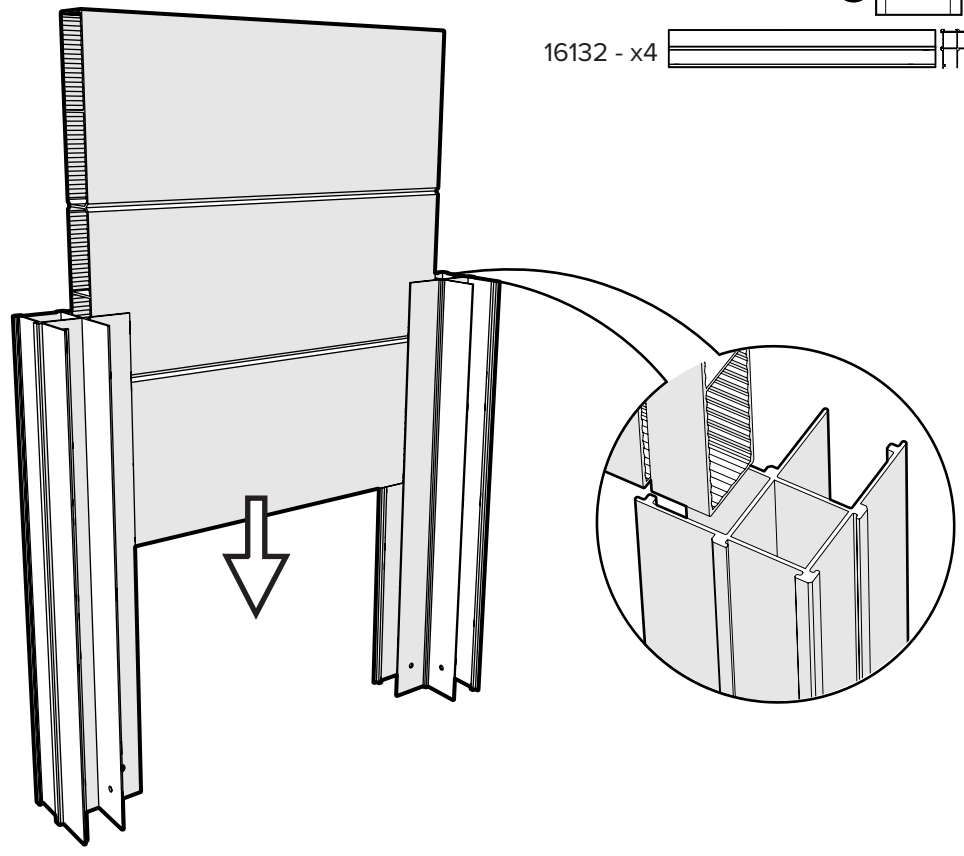

X2



2

20066 - x4 (A)

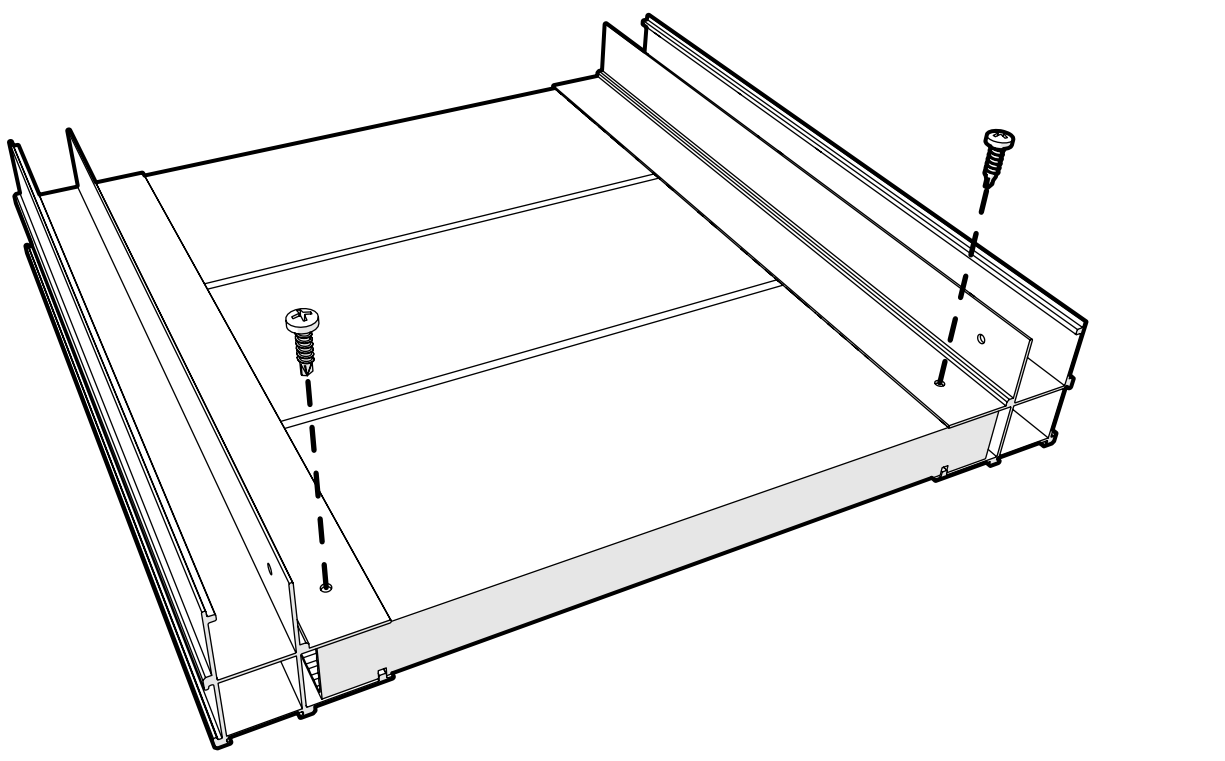

X2

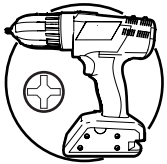

PHILIPS #2

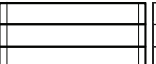

3

16141 - x2 (A) 

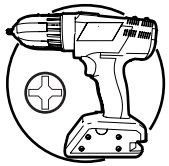
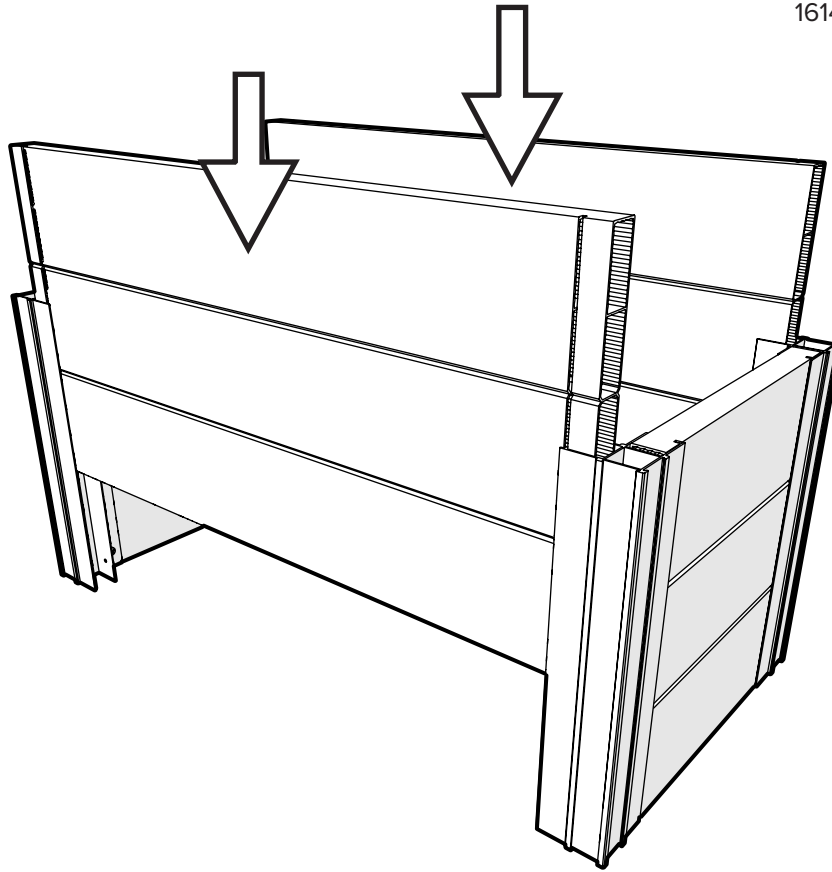

PHILIPS #2

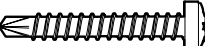

4

20080 - x6 (B) 

20066 - x4 (A) 

16144 - x2 

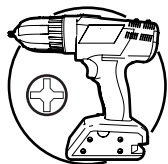
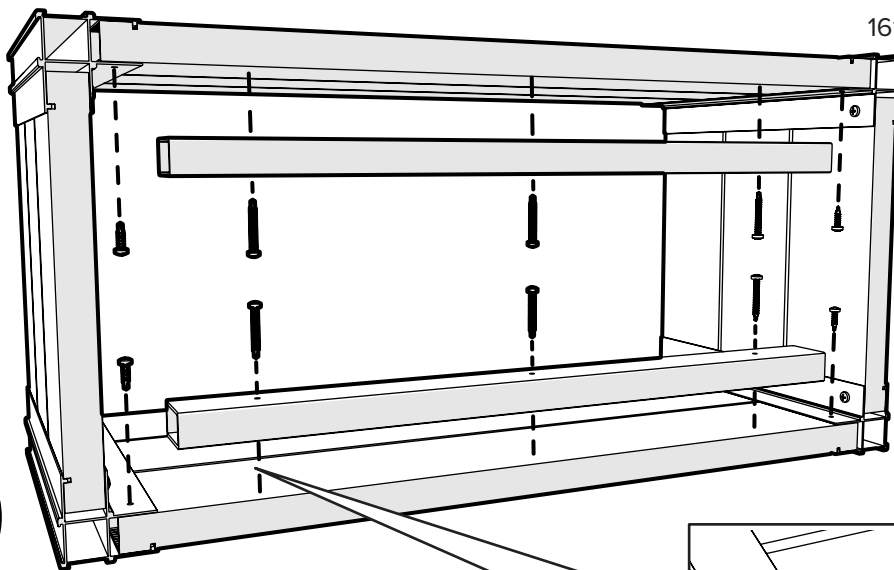

PHILIPS #2

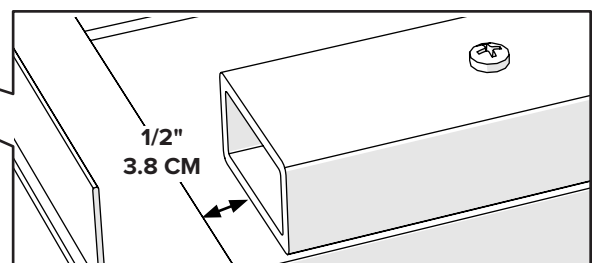

5



16145 - x1

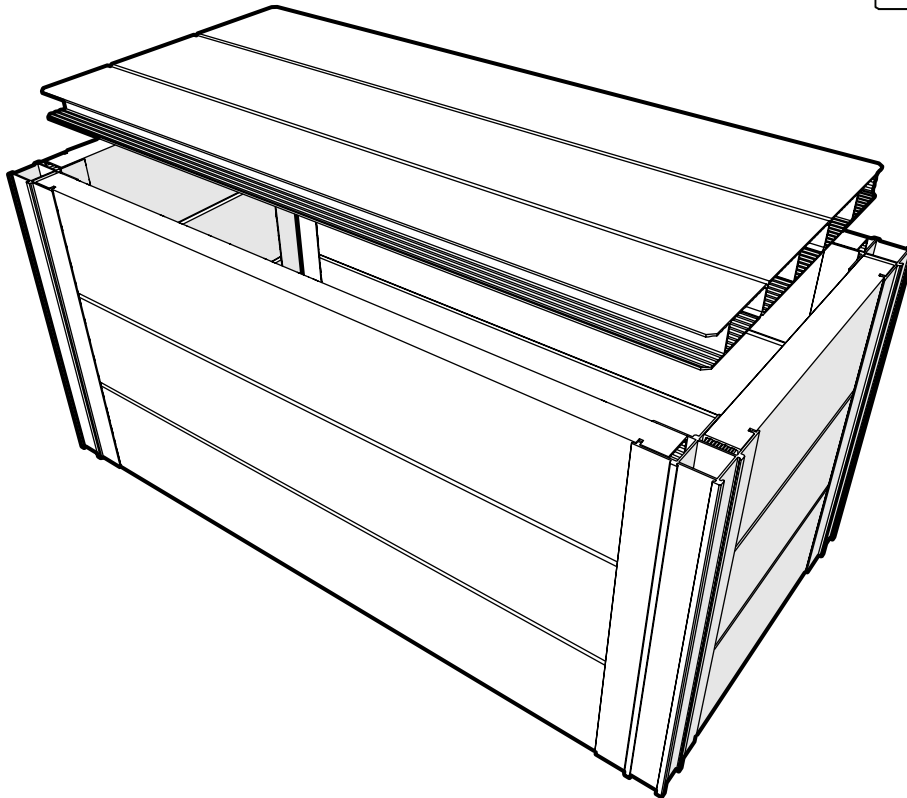
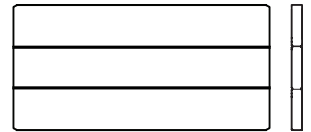

6

16325 - x8

