

ASSEMBLY INSTRUCTIONS

Wheelchair Accessible Raised Planter Box

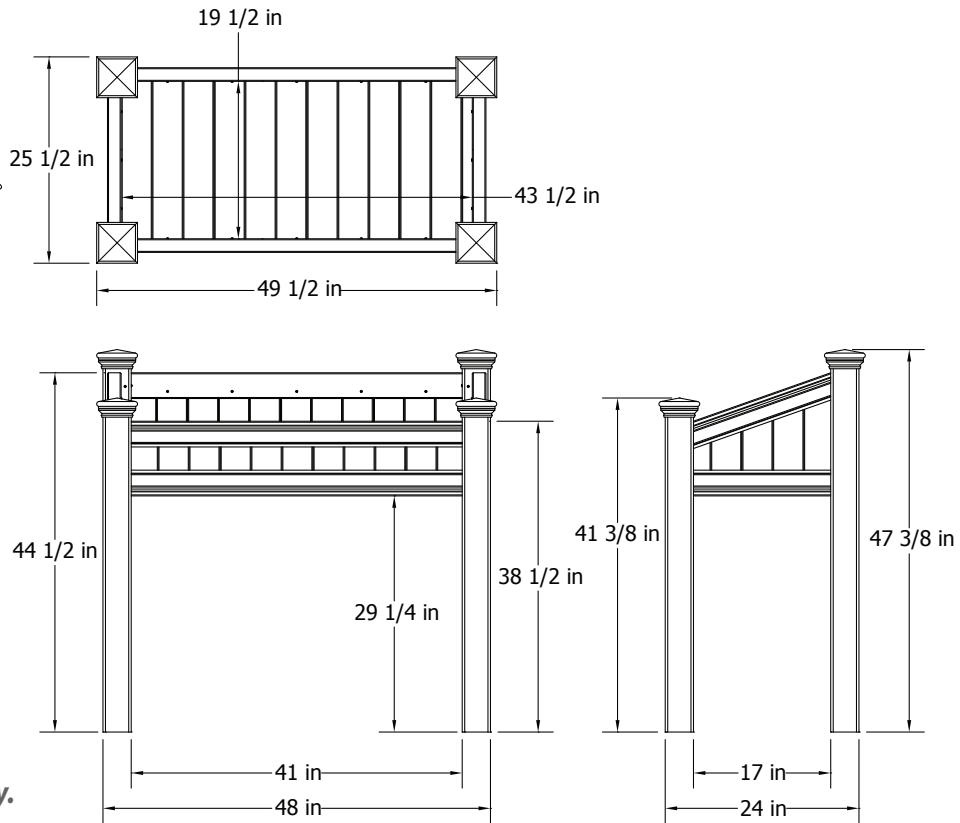
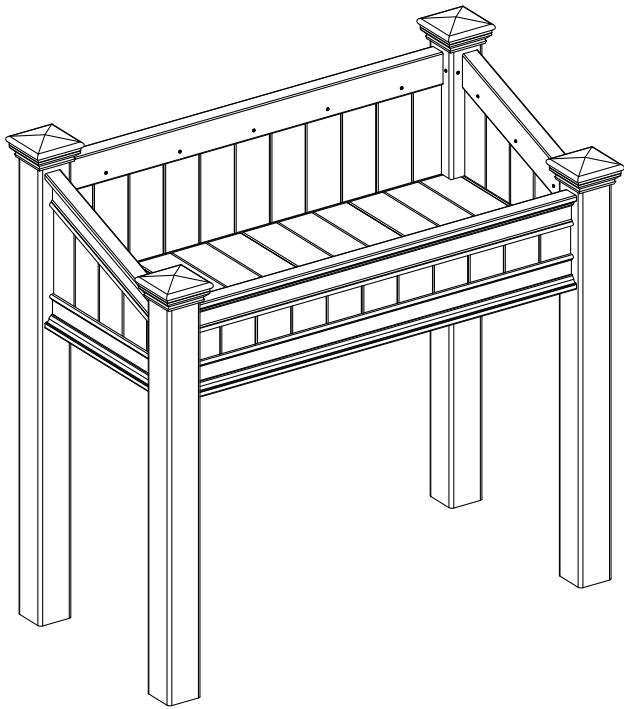

Please read through before starting assembly.

Check Box for These Contents

In the event of missing or defective parts please call our customer service dept. at **1 800 282 9346** (Mon. to Fri. 8:00 AM to 5:00 PM EST).

1. Pre-Assembled Left Side Wall Panel with Posts Connected (1)
2. Pre-Assembled Right Side Wall Panel with Posts Connected (1)
3. Pre-Assembled Front Wall Panel (1)
4. Pre-Assembled Rear Wall Panel (1)
5. Post Caps (4)
6. Floor Board A (1)
Floor Board B (2)
Floor Board C (1)
7. Corner Braces (2)
8. Left Brace (1)
9. Center Brace (1)
10. Right Brace (1)
11. 2 1/2" Self-Auguring Stainless Steel Screws (8)

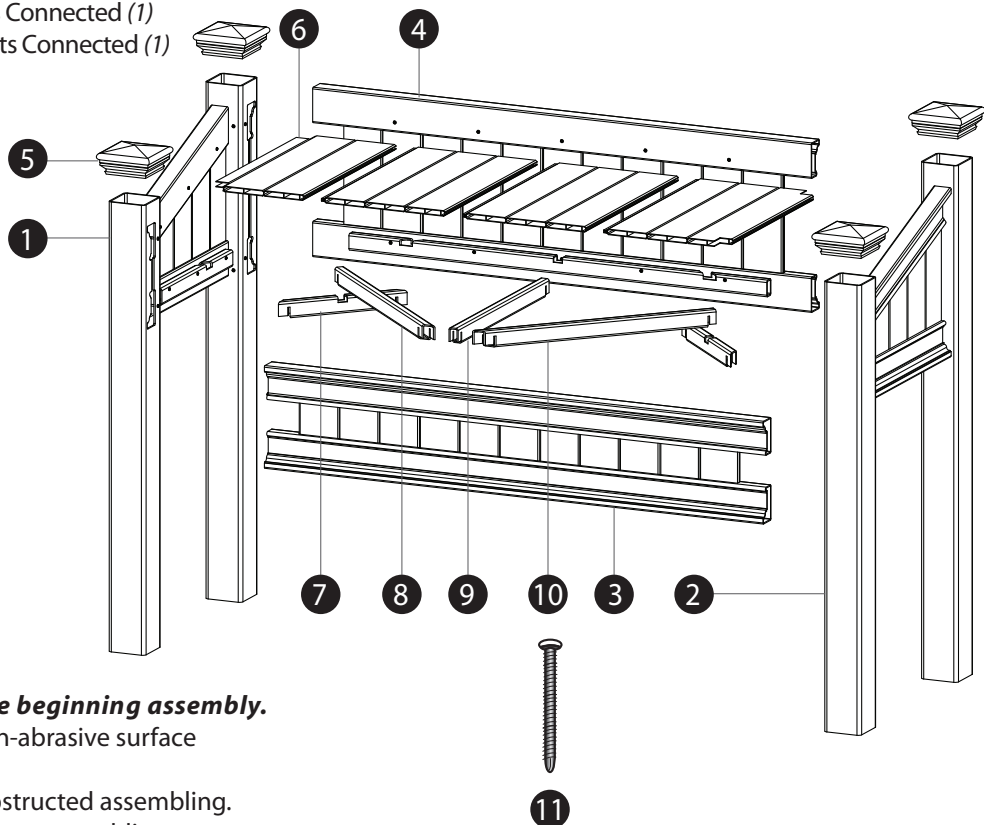

Not to Scale

General Information

- Read Instructions through carefully before beginning assembly.
- When assembling components, place on a non-abrasive surface (i.e. shipping box) to avoid scratching.
- We recommend an area approx 4'x 8' for unobstructed assembling.
- You should not need to use excessive force when assembling components.

STEP ONE

1

Lay the pre-assembled left side wall with posts connected on its side as shown and insert the pre-assembled rear wall panel. Excessive force should not be used. Insert until the rear wall panel bottoms out inside the post.

2

Secure the rear panel in place using two of the screws provided through the pre-drilled holes.

3

Similarly, insert the pre-assembled front panel as shown. Insert until the front wall panel bottoms out inside the post.

4

Secure the front panel in place using two of the screws provided through the pre-drilled holes.

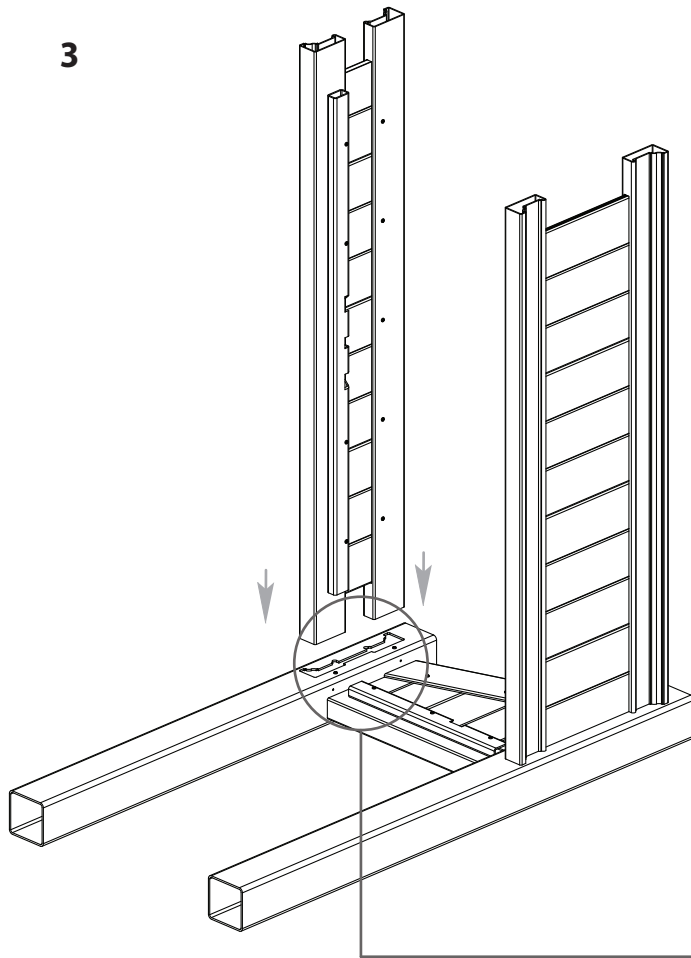
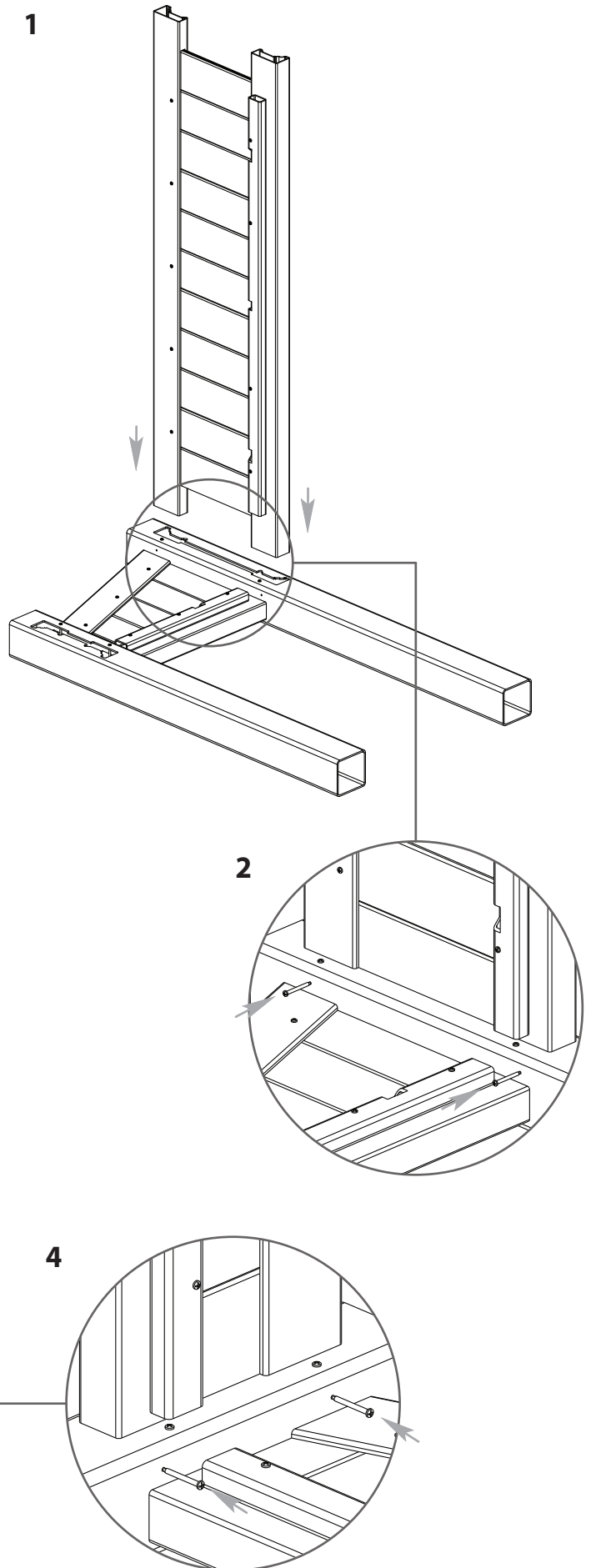

vita

STEP TWO

1

Insert the pre-assembled right side wall with posts connected to the assembly from the previous step. Excessive force should not be used. Insert until the front and rear wall panels bottom out inside the posts.

2

Carefully stand the assembly up as shown. While ensuring that the front and rear walls are bottoming out inside the posts, secure the front panel in place using two of the screws provided through the pre-drilled holes

3

Repeat step 2 for the rear panel.

1

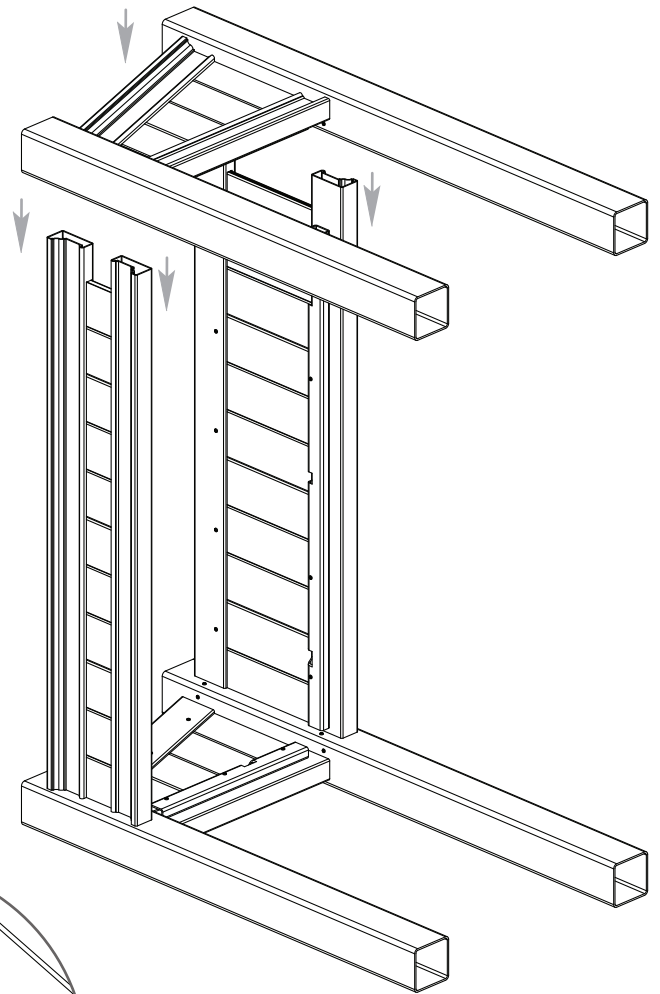

2

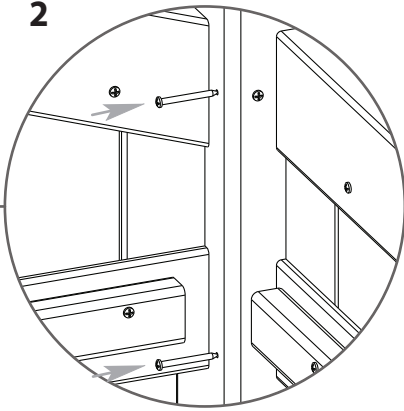

3

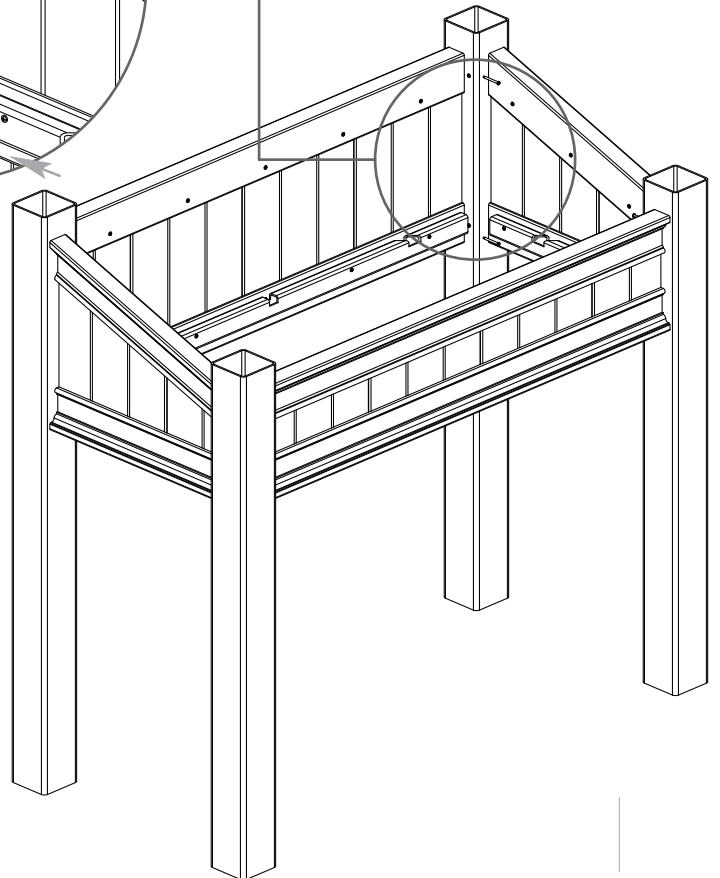
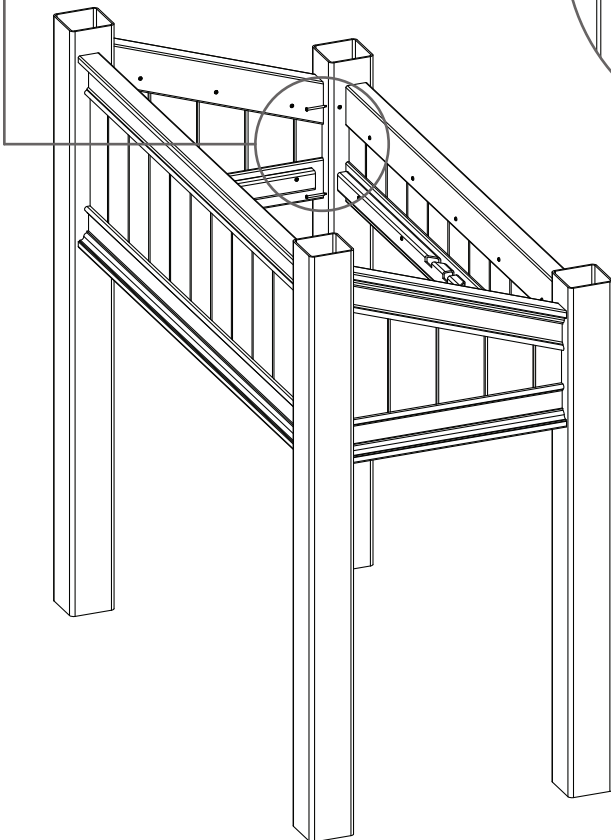
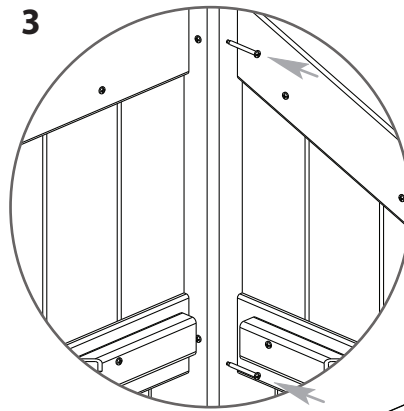

STEP THREE

1

Connect the center brace between the front and rear wall panels as well as the two corner braces between the rear and side panels as shown. Excessive force should not be used.

Note that the corner braces will only connect one way.

2

Connect the left and right braces between the corner braces and front wall panel as shown.

Note that the left and right braces will only connect one way.

1

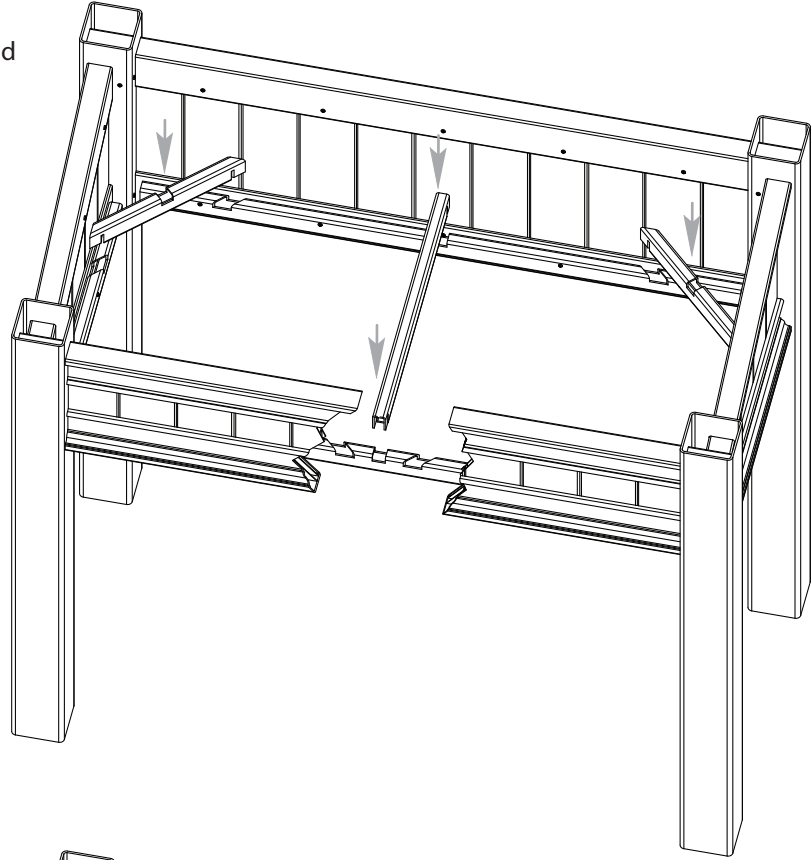

2

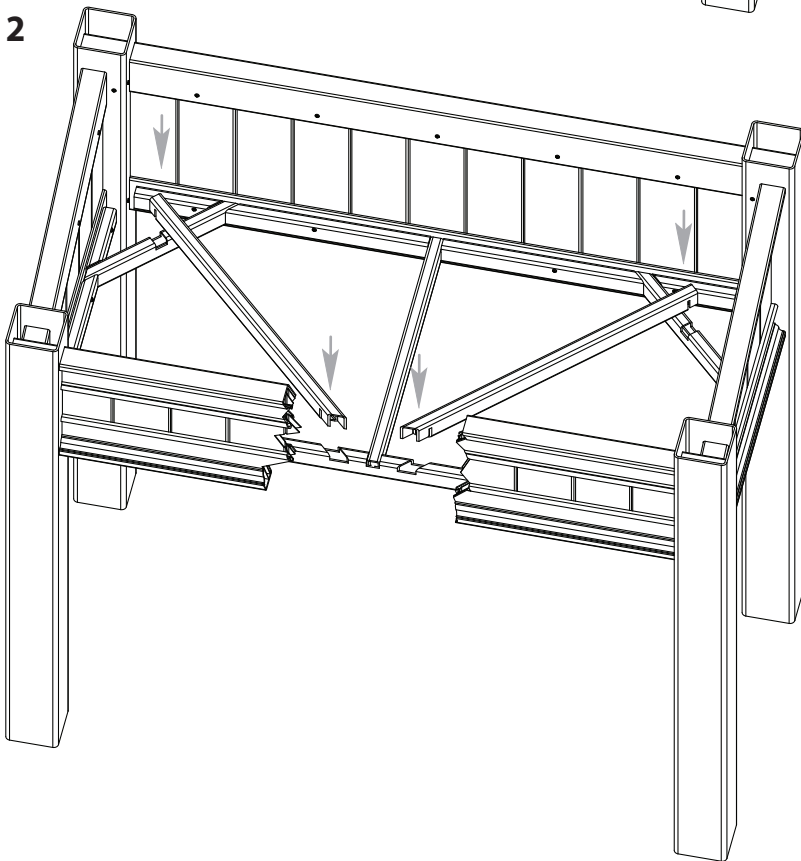

vita

STEP FOUR

1

Insert one of the notched floor boards onto the brace assembly as shown. The notched corners should be nested inside the posts.

2

One by one, add the remaining floor boards. Note that there are different types of boards and they are tongue-and-grooved to lock into each other.

3

Pressure fit the four post caps onto the posts as shown.

