

x3



2h



**Thank you for ordering from  
Mamas & Papas.**

---

**For over 30 years, we have been** committed to creating a world of quality, individuality and style for parents around the world. At the very beginning we were inspired by our daughters — now we see them all grown up, with children of their own, helping us to share our passion for parenting to their generation of Mums and Dads. We hope you enjoy exploring our new collection and wish you a very warm welcome to our world.

We are committed to designing and developing products to the highest standards, for your family to enjoy and we welcome any feedback or comments you may have.

**The Mamas & Papas Family.**

**Gracias por elegir  
Mamas & Papas.**

---

**Durante más de 30 años,** nuestro compromiso ha sido crear un mundo de calidad, individualidad y estilo para padres de todo el mundo. Al principio nos inspiraron nuestras propias hijas, que ahora son adultas y tienen sus propios hijos, y nos ayudan a compartir nuestra pasión por la paternidad con su generación de mamás y papás. Esperamos que disfruten descubriendo nuestra nueva colección y les damos una calurosa bienvenida a nuestro mundo.

Nos comprometemos a diseñar y elaborar productos de la mejor calidad, con el fin de que su familia los disfrute y nosotros recibamos las respuestas y comentarios que le puedan surgir.

**La Familia Mamas & Papas.**

**Merci d'avoir choisi  
Mamas & Papas.**

---

**Cela fait plus de 30 années** que nous nous consacrons à créer un monde de qualité, d'individualité et de style pour les parents dans le monde entier. Au tout début, nous étions inspirés par nos filles — à présent celles-ci ont grandi, elles ont des enfants aussi et nous aident à partager avec vous notre passion de création en nous adressant à leur génération de mamans et de papas. Nous espérons que vous passerez un agréable moment à découvrir notre nouvelle collection et nous sommes heureux de vous accueillir dans notre monde.

Nous nous engageons à concevoir et à développer des produits de la plus haute qualité, pour le plaisir de votre famille et nous serions heureux de recevoir vos réactions et observations éventuelles.

**La Famille Mamas & Papas.**

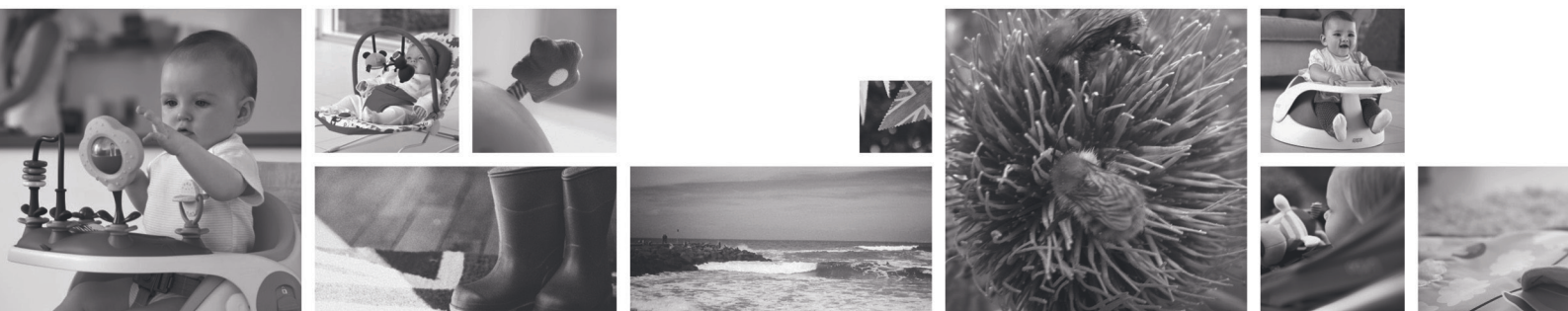

## für Mamas & Papas entschieden haben.

---

Seit über 30 Jahren entwickeln wir mit großem Engagement für Eltern in aller Welt Produkte, die für Qualität, Individualität und Stil stehen. Die erste Inspiration gaben uns unsere Töchter, die mittlerweile erwachsen sind, selbst Kinder haben und uns nun dabei helfen, die Mütter und Väter ihrer Generation mit unserer Begeisterung für Babyprodukte anzustecken. Wir hoffen, dass es Ihnen Spaß machen wird, sich unsere neue Kollektion anzusehen, und heißen Sie herzlich willkommen in unserer Welt.

Wir haben es uns zur Aufgabe gemacht, Produkte auf höchstem Niveau zu entwerfen, die Ihre Familie genießen kann. Daher freuen wir uns immer über Ihr Feedback oder Ihre Kommentare.

## Die Mamas & Papas-Familie.

## Grazie per aver scelto Mamas & Papas.

---

Da oltre 30 anni lavoriamo per creare un mondo di qualità, unicità e stile per i genitori di tutto il mondo. All'inizio abbiamo tratto ispirazione dalle nostre figlie; adesso che sono cresciute e hanno a loro volta dei figli, ci aiutano a far conoscere alla loro generazione di mamme e papà la nostra passione nel vivere l'esperienza di genitori. Ci auguriamo che apprezzerete la nostra nuova collezione e vi diamo un caloroso benvenuto nel nostro mondo

Il nostro impegno è quello di progettare e realizzare prodotti rispondenti agli standard più elevati per la vostra famiglia e saremo lieti di ricevere suggerimenti o commenti da parte vostra.

## La famiglia di Mamas & Papas.

## Hartelijk dank dat u voor een product van Mamas & Papas heeft gekozen.

---

Al meer dan 30 jaar zetten wij ons in om een wereld van kwaliteit, individualiteit en stijl te scheppen voor ouders verspreid over de hele aardbol. In het begin werden we geïnspireerd door onze eigen dochters. Nu die volwassen zijn en zelf kinderen hebben, helpen zij ons onze passie voor ouderschap te delen met vaders en moeders van hun eigen generatie. We hopen dat u onze nieuwe collectie met plezier zult verkennen en heten u van harte welkom in onze wereld.

Wij hopen dat u met uw gezin van onze producten zult genieten en mocht u feedback willen geven of andere opmerkingen hebben, dan horen we graag van u.

## De Mamas & Papas Familie.



**EN** **IMPORTANT!**  
**RETAIN FOR FUTURE REFERENCE:**  
**READ CAREFULLY**

---

**ES** **¡IMPORTANTE!**  
**LEA ESTAS INSTRUCCIONES DETENIDAMENTE Y**  
**GUÁRDELAS PARA FUTURA REFERENCIA**

---

**FR** **IMPORTANT !**  
**VEUILLEZ LIRE CES CONSIGNES AVEC ATTENTION**  
**ET LES CONSERVER POUR VOUS Y REPORTER**  
**ULTÉRIEUREMENT**

---

**D** **ACHTUNG!**  
**BITTE LESEN SIE SICH DIESE ANWEISUNGEN**  
**SORGFÄLTIG DURCH UND BEWAHREN SIE SIE FÜR**  
**ZUKÜNFTIGE VERWENDUNG AUF**

---

**IT** **IMPORTANTE!**  
**LEGGERE ATTENTAMENTE QUESTE ISTRUZIONI E**  
**CONSERVARLE COME RIFERIMENTO FUTURO**

---

**NL** **BELANGRIJK!**  
**BEWAAR VOOR TOEKOMSTIGE REFERENTIE:**  
**LEES DIT ZORGVULDIG DOOR**

---

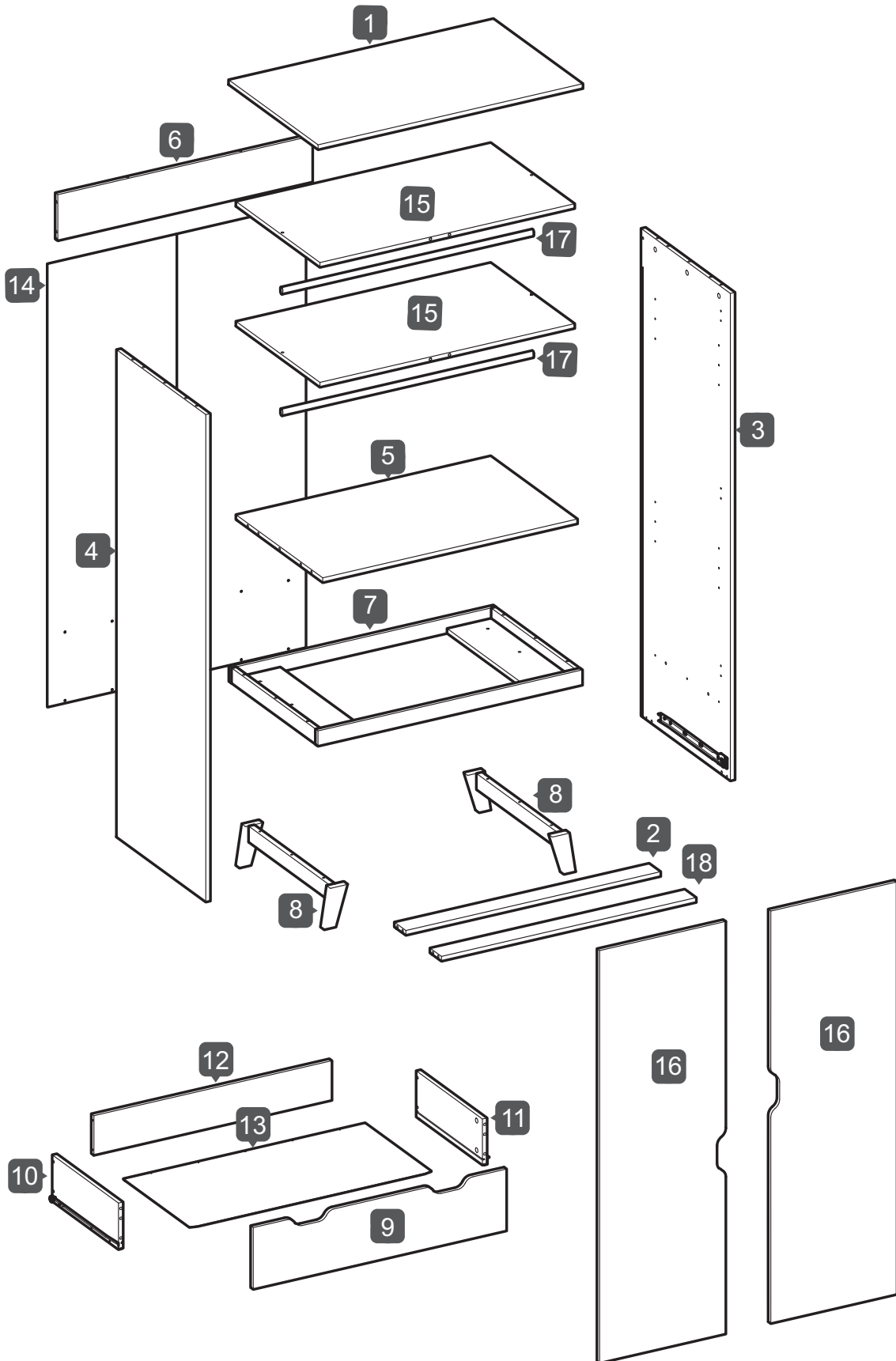
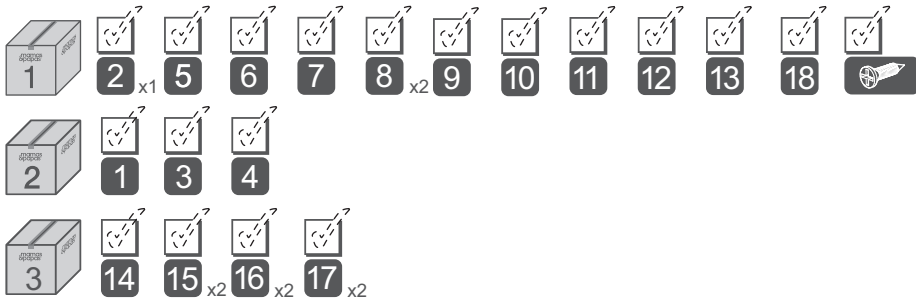

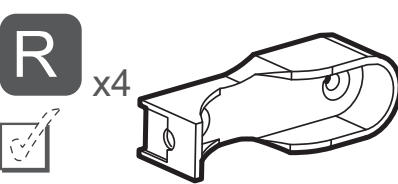
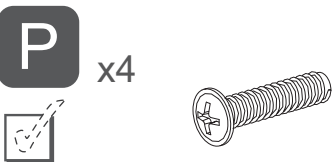
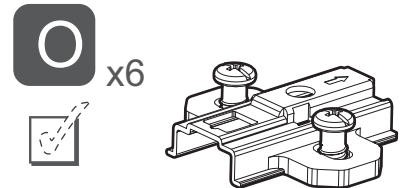
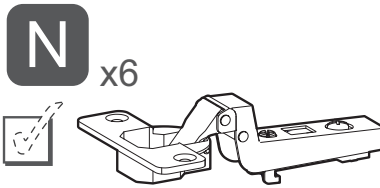
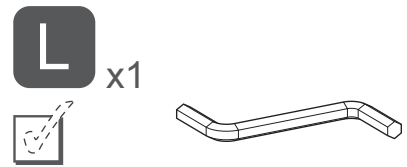
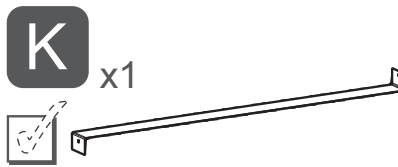
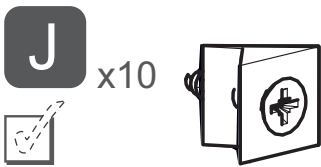
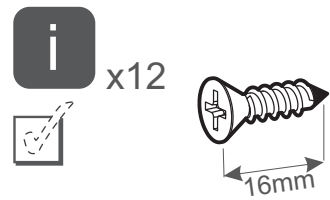
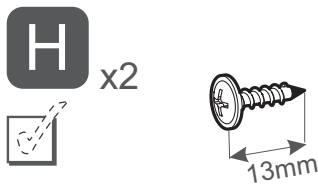
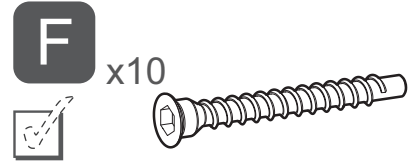
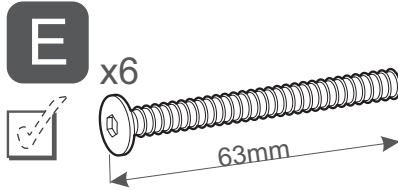
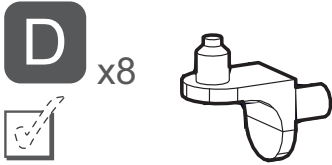
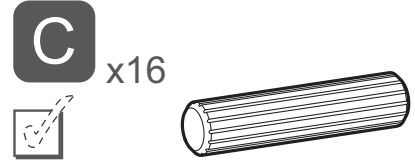
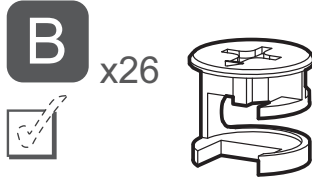
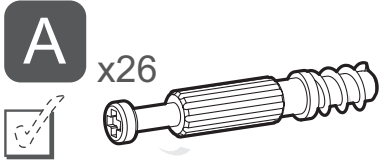
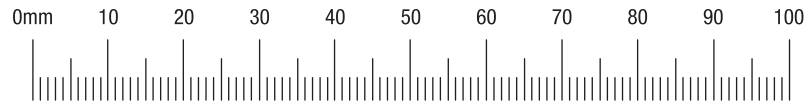

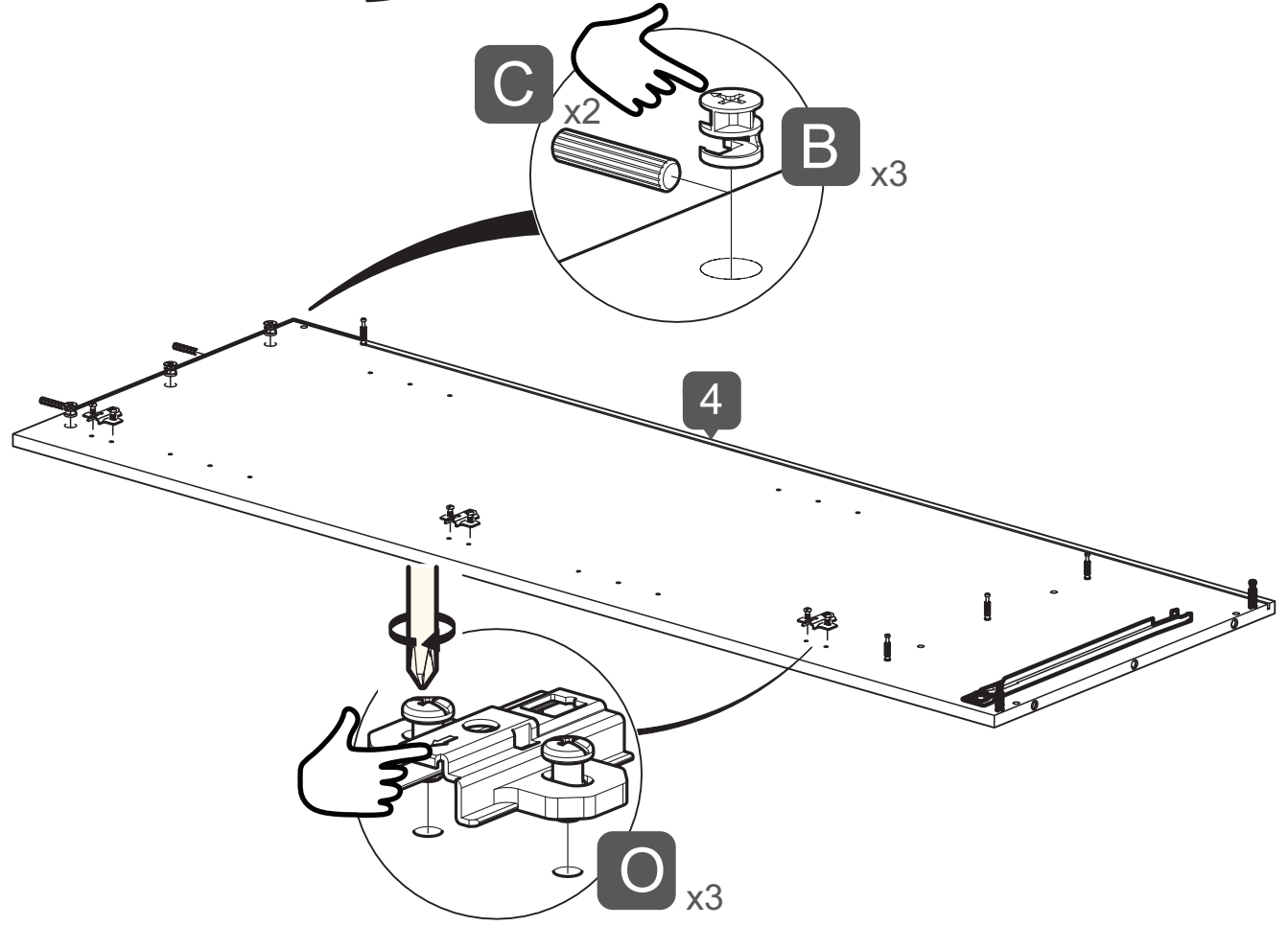
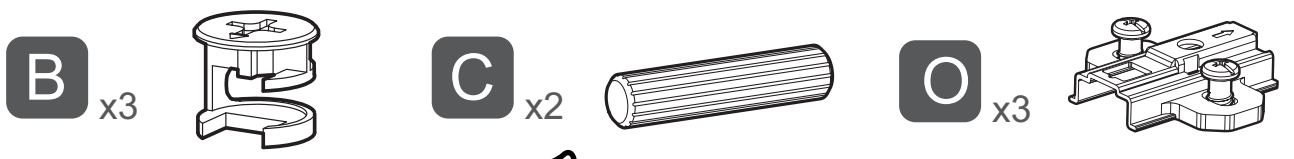
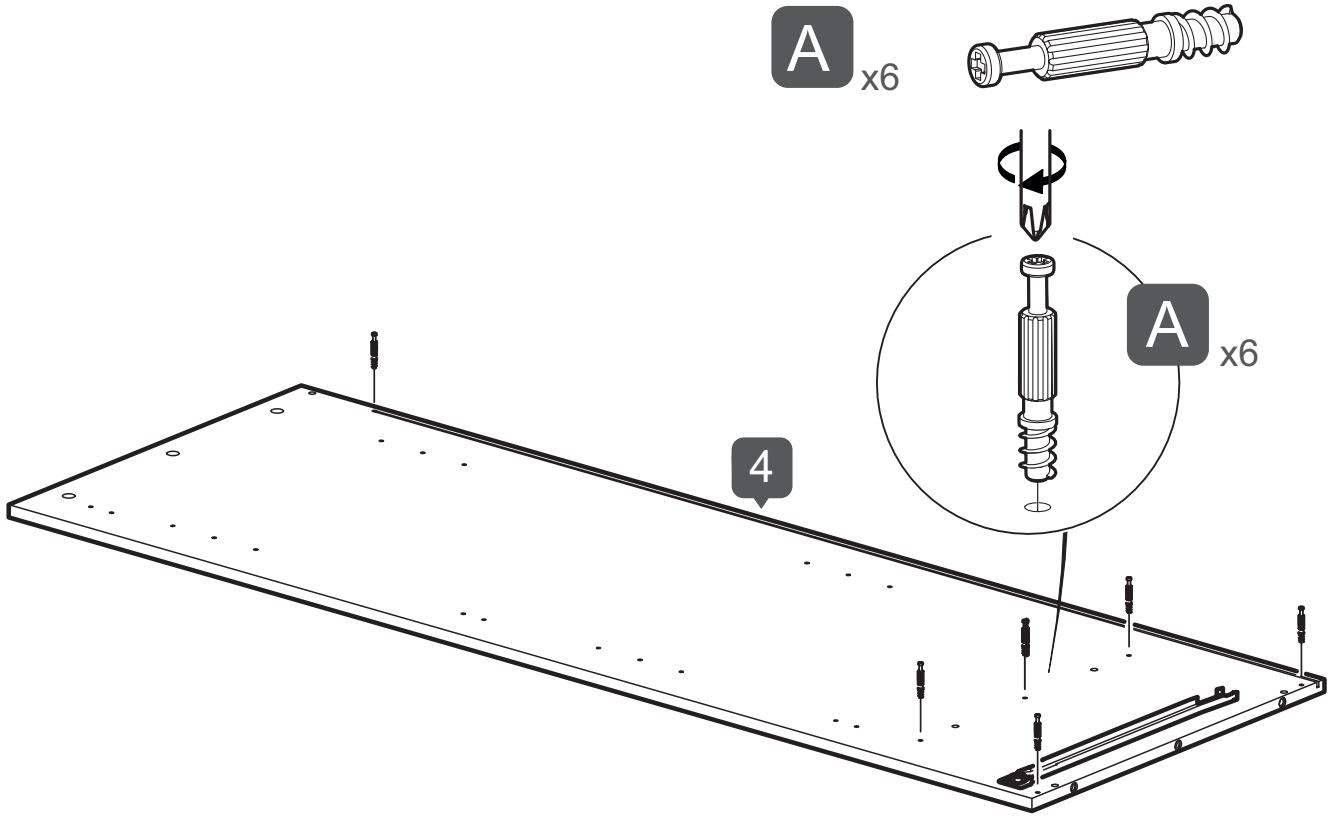

2

**A** x6

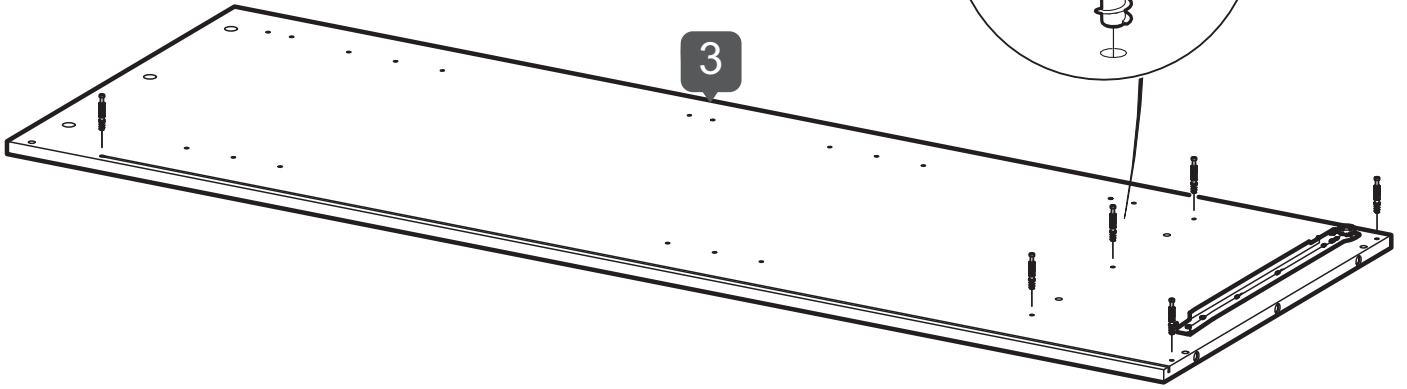
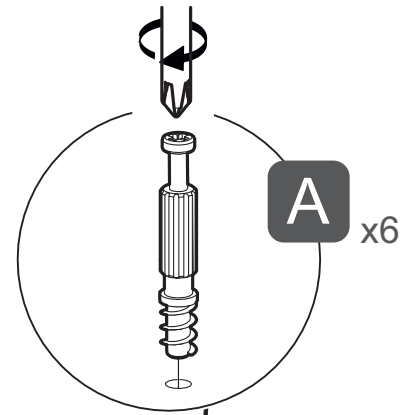
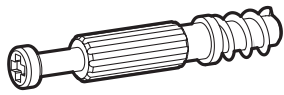

**B** x3

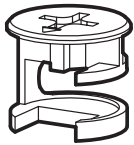

**C** x2



**O** x3

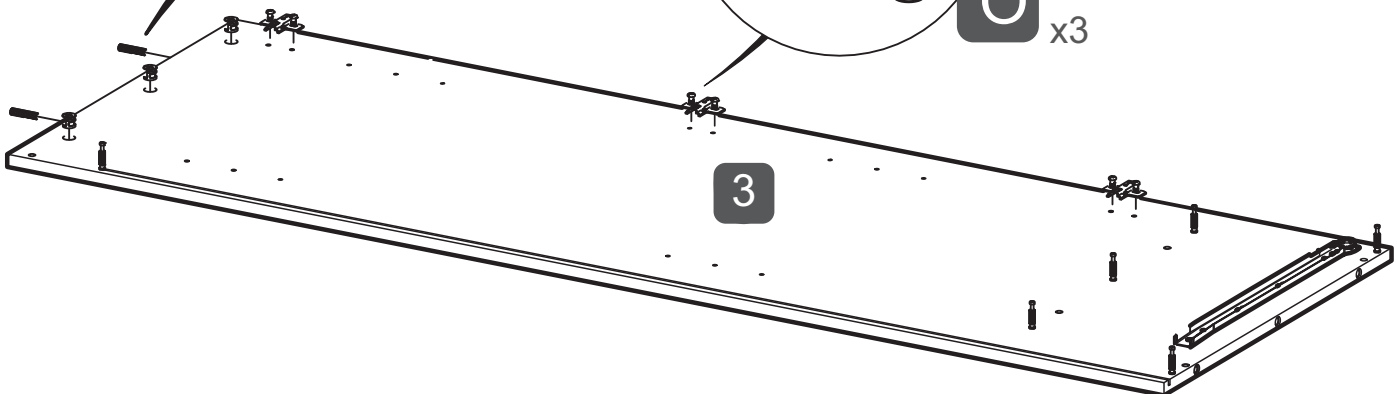
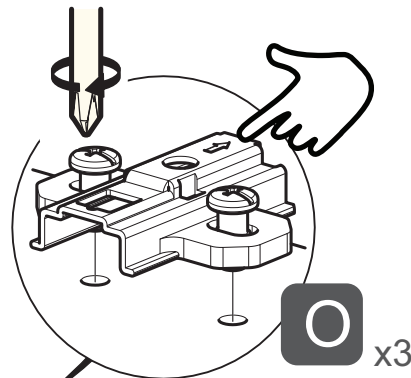
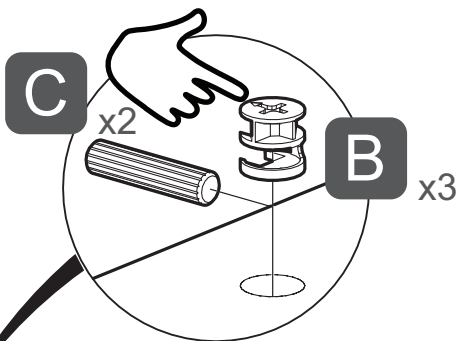
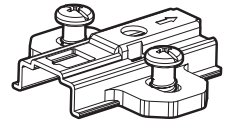



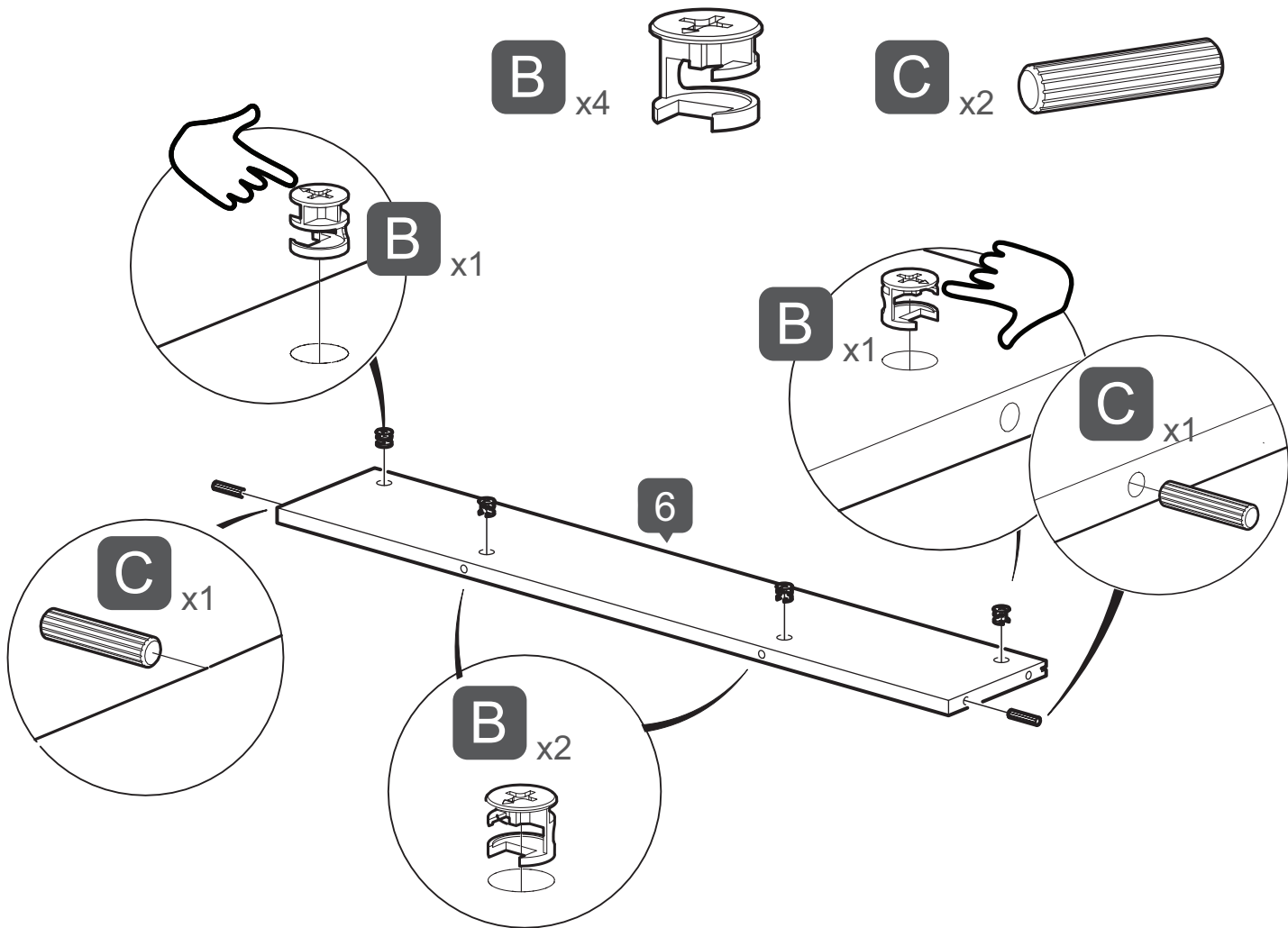
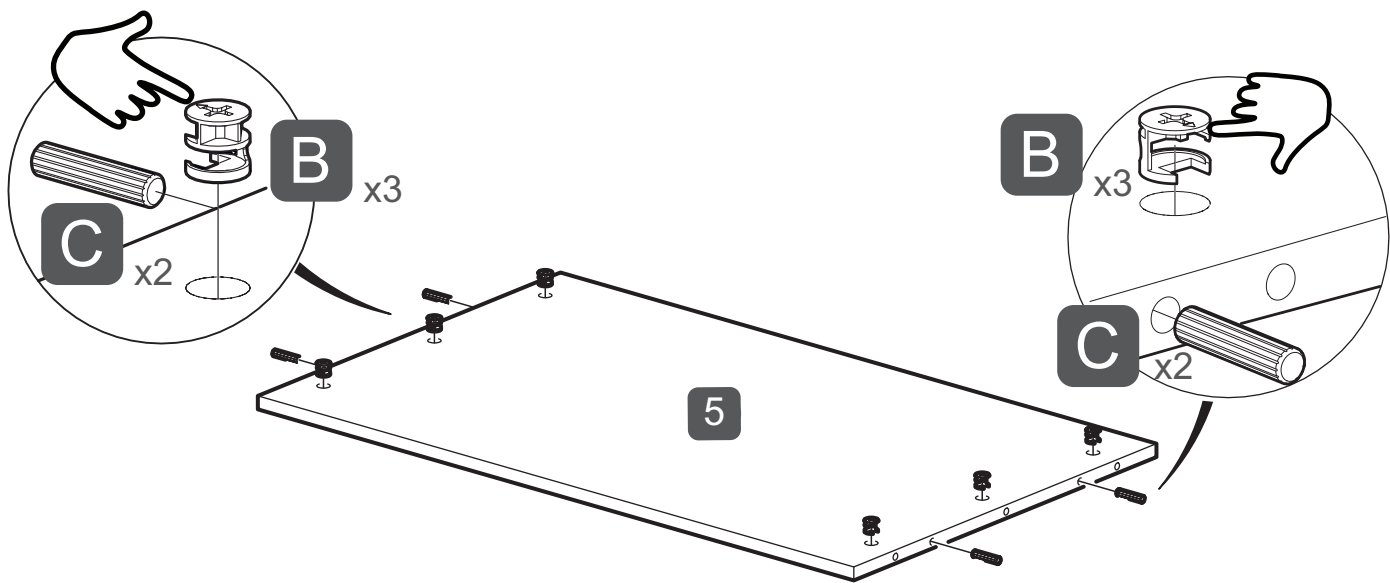

4

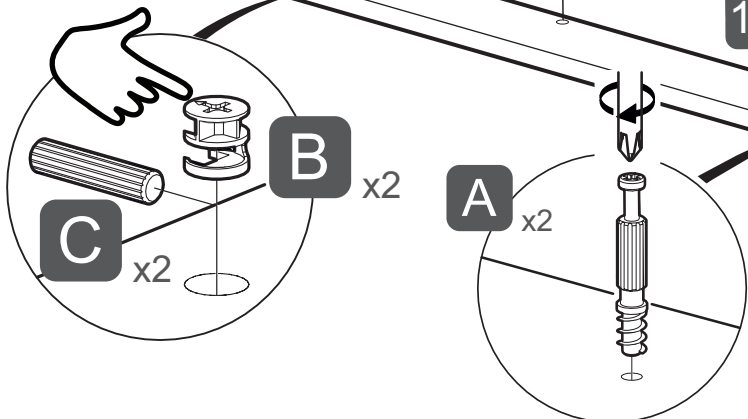
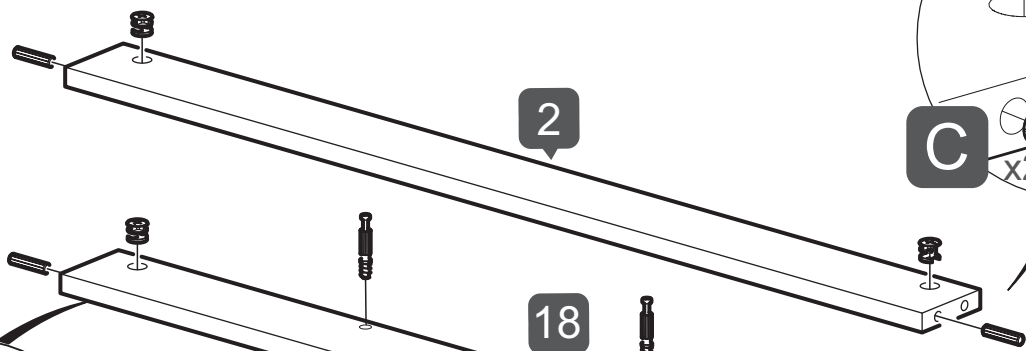
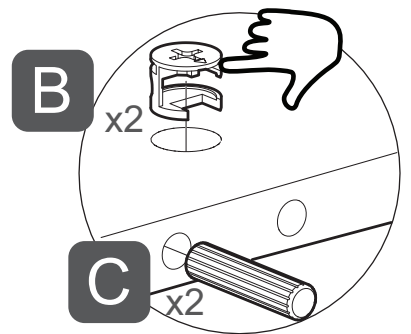
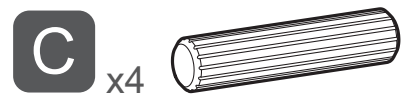
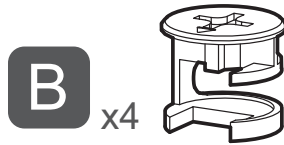
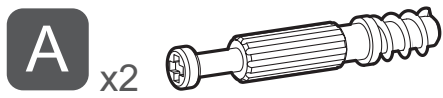
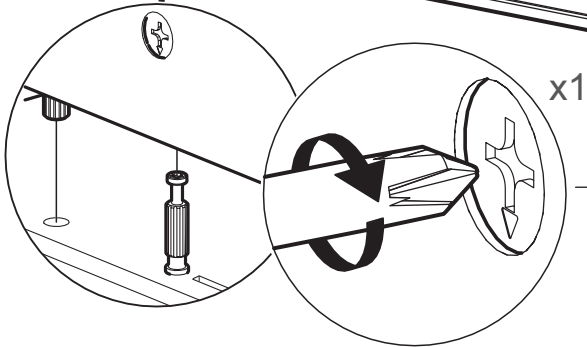
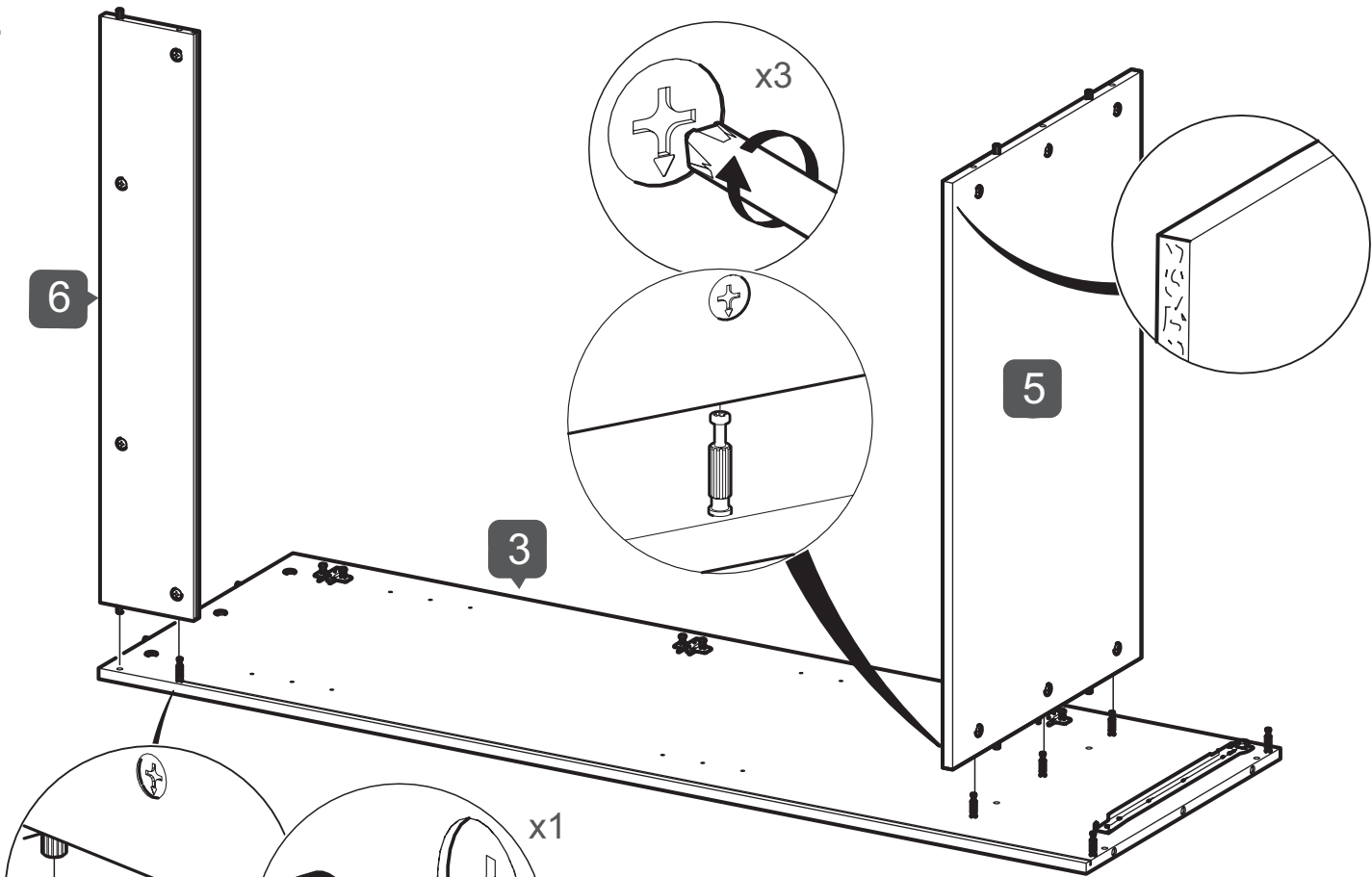

18

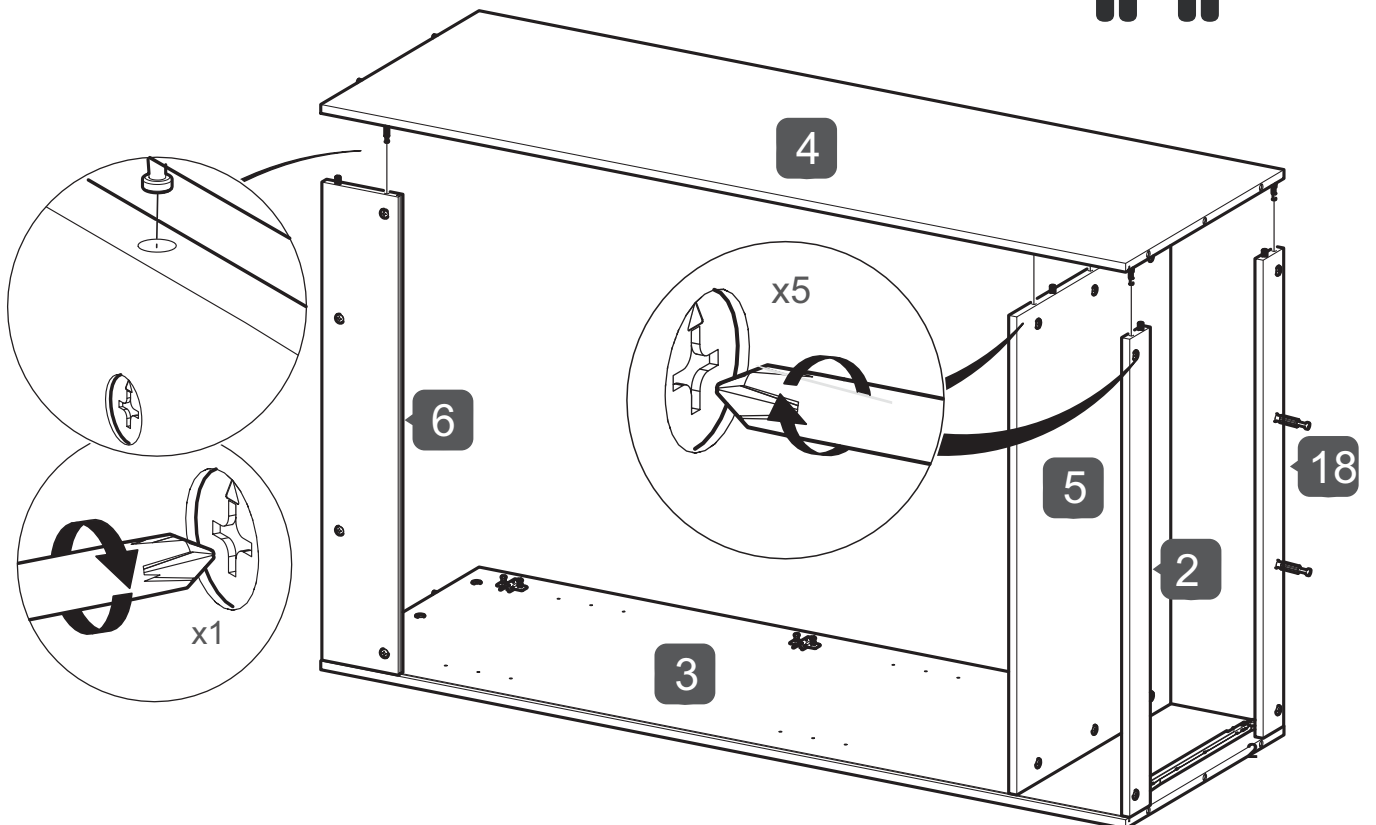
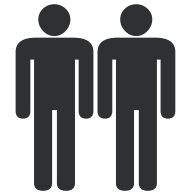
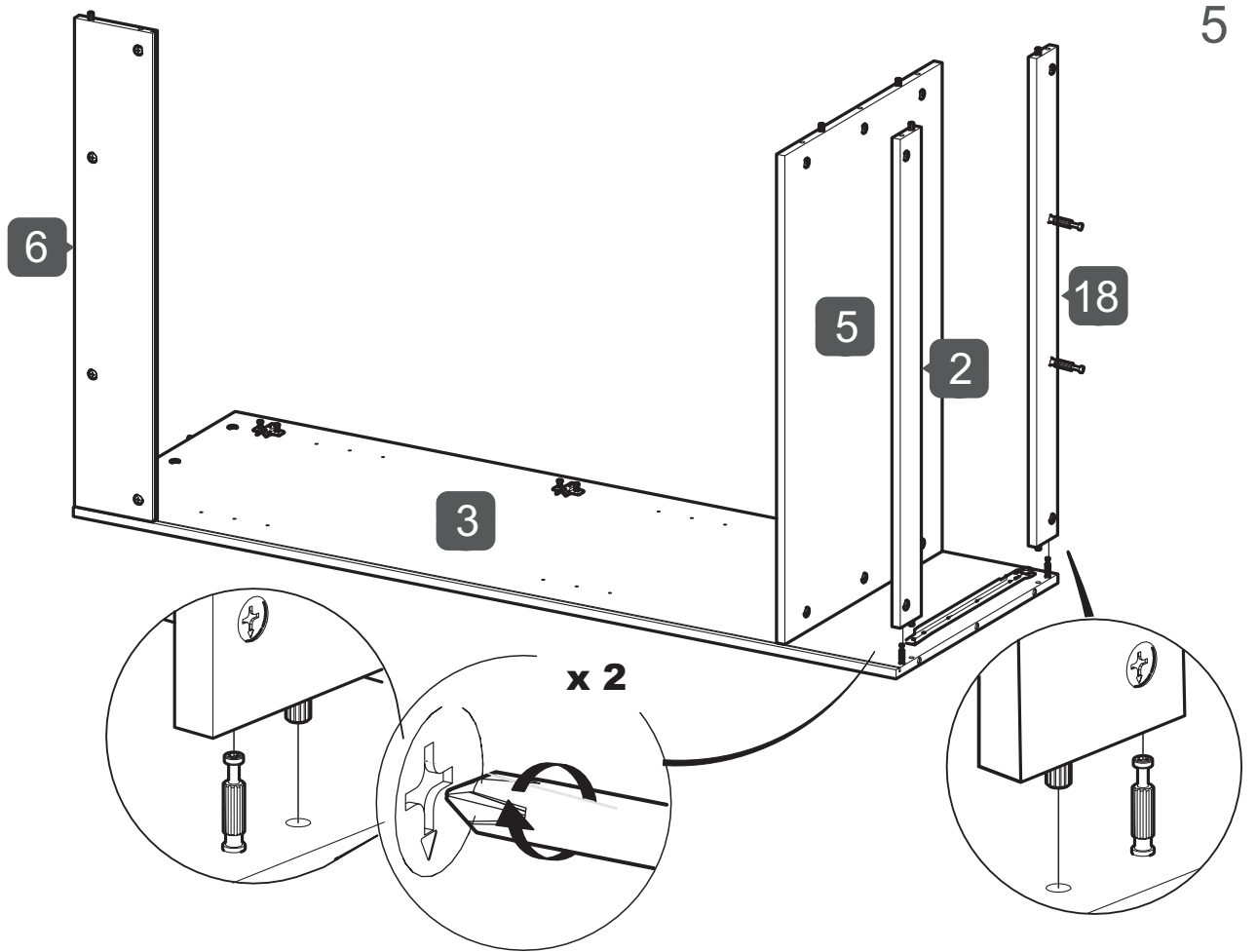

6

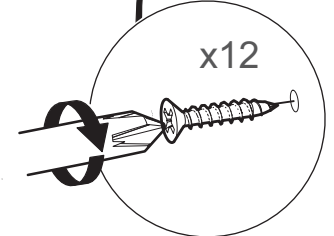
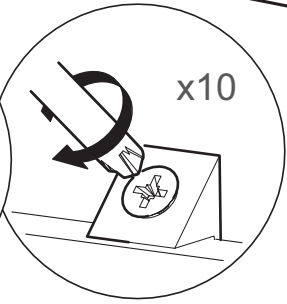
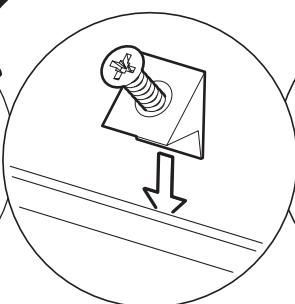
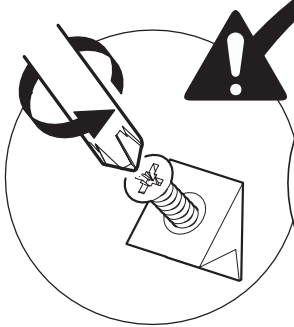
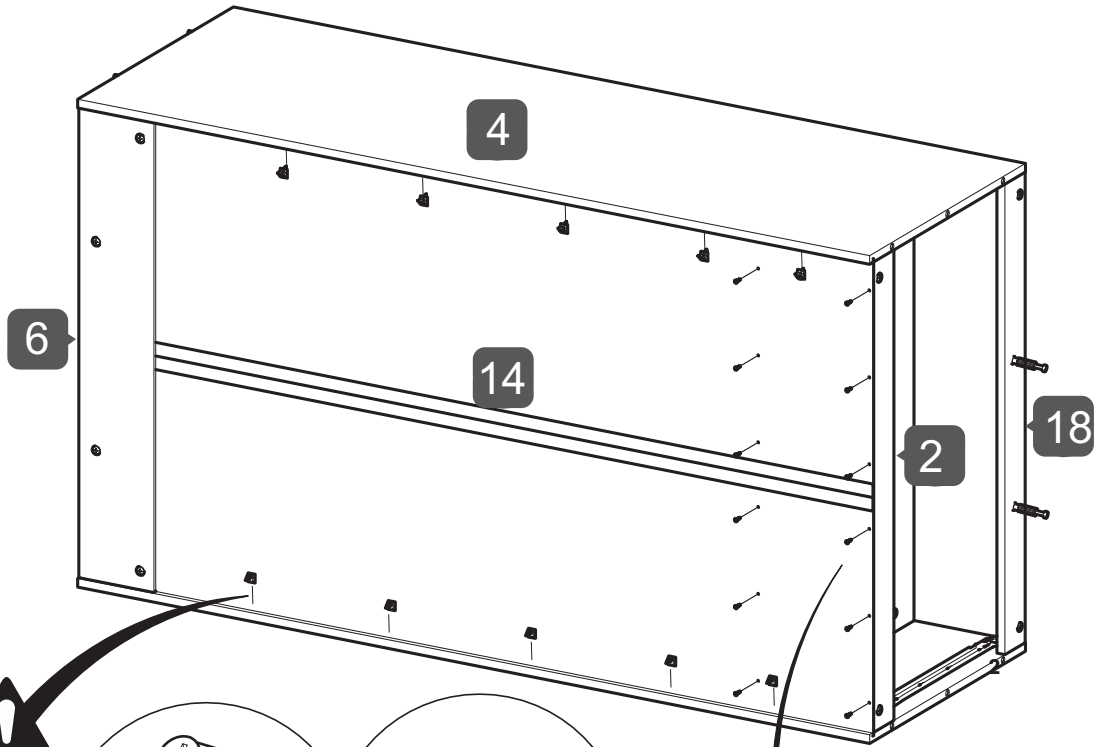
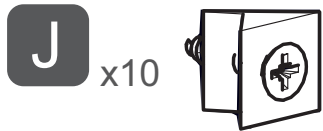
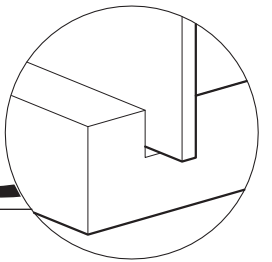
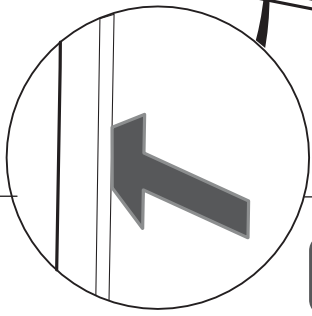
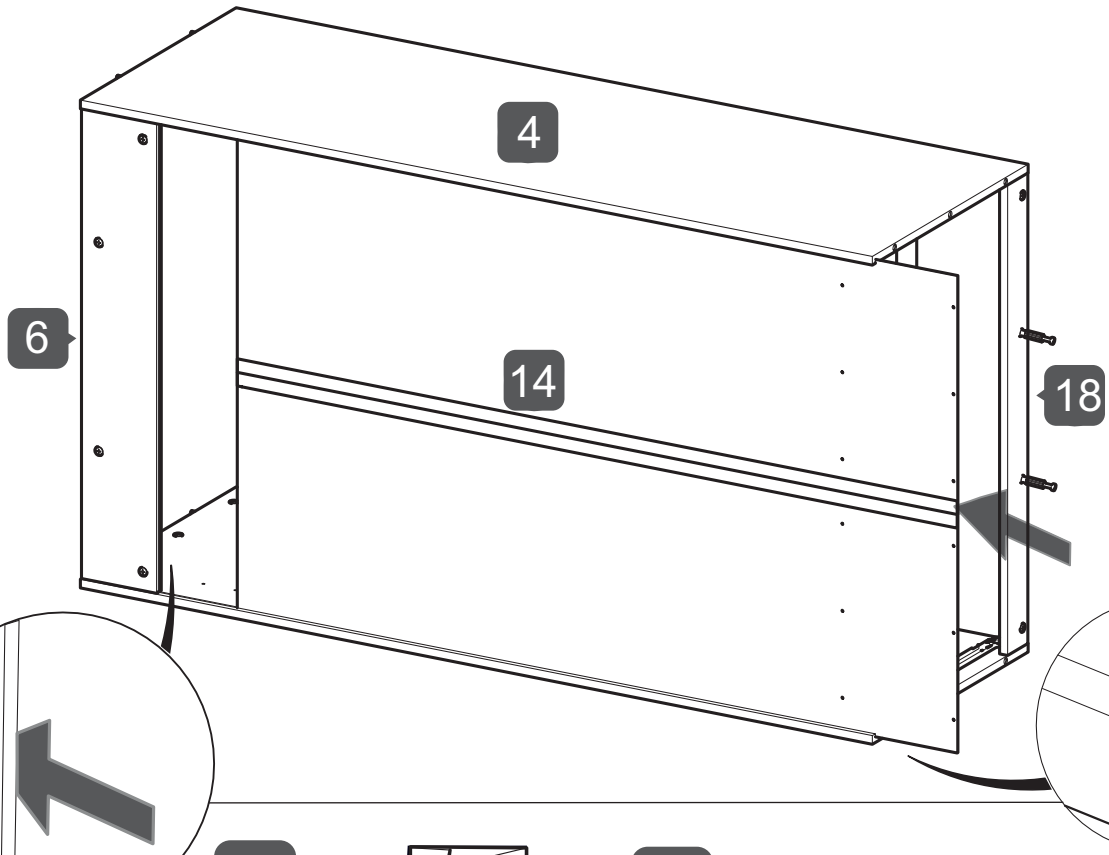

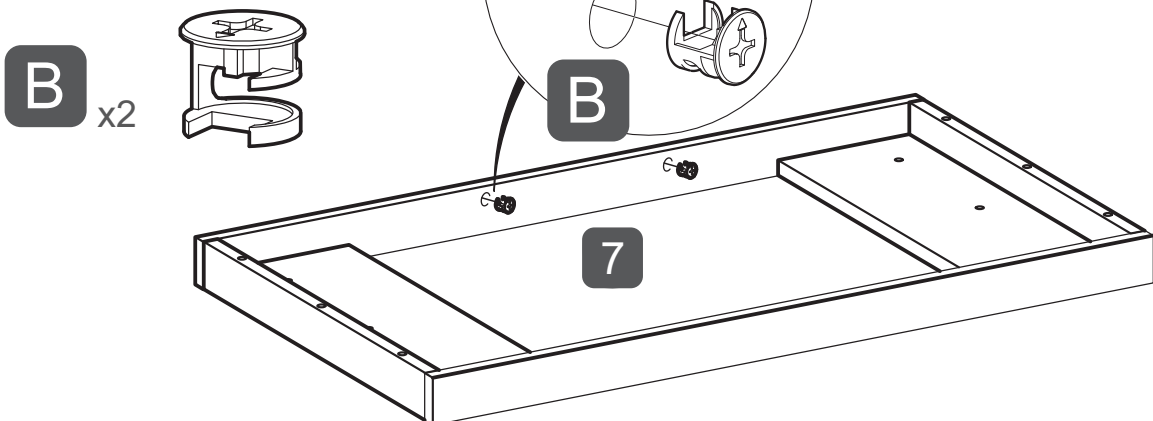
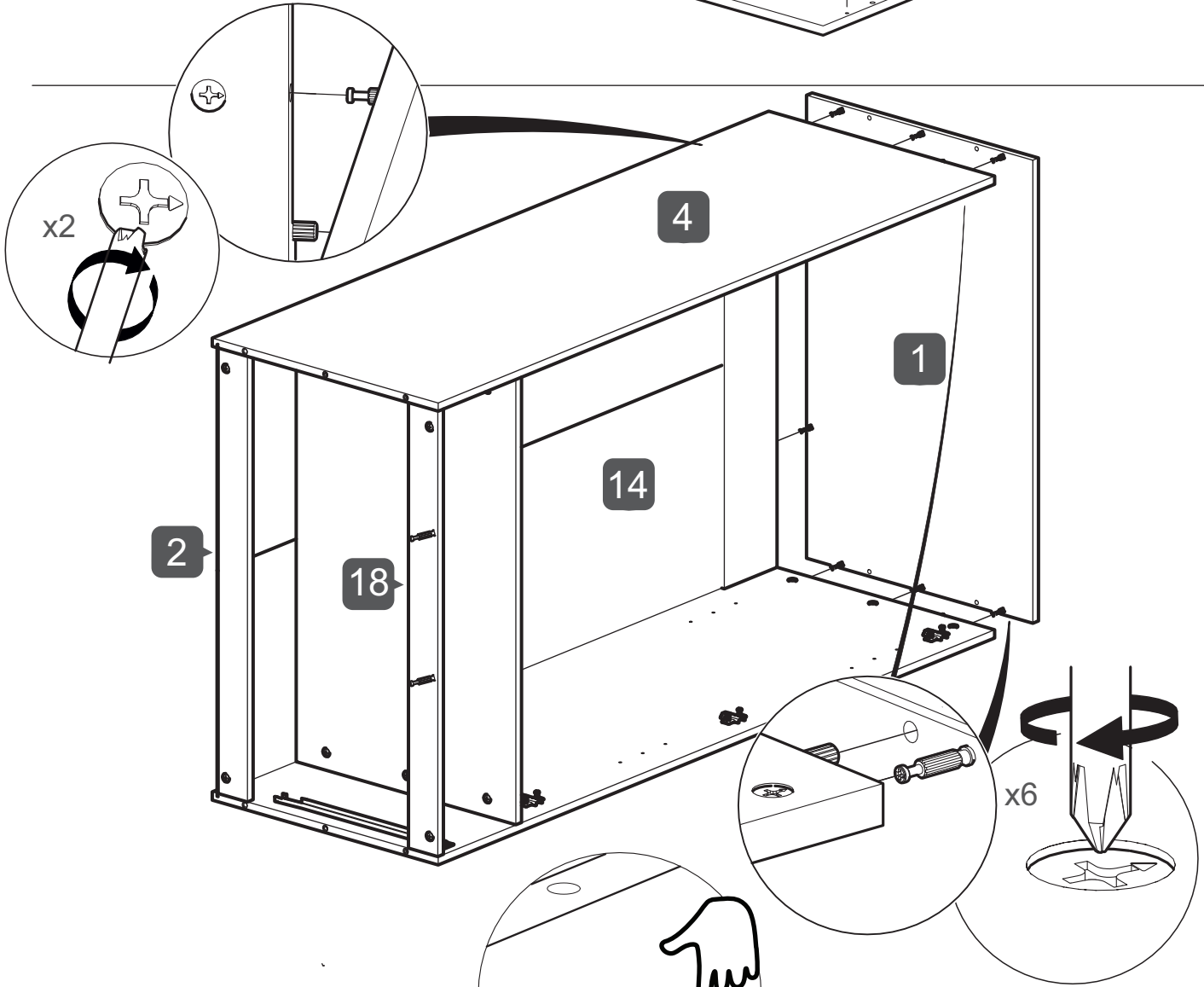
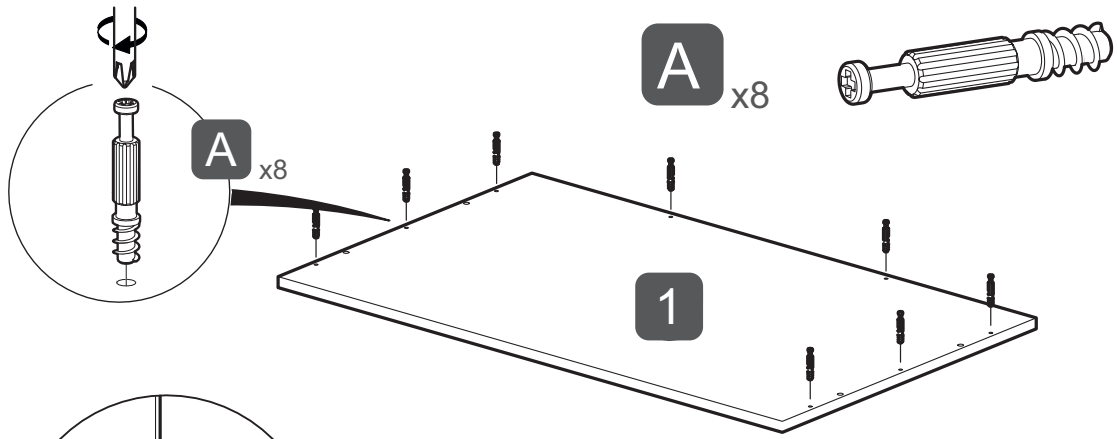

8

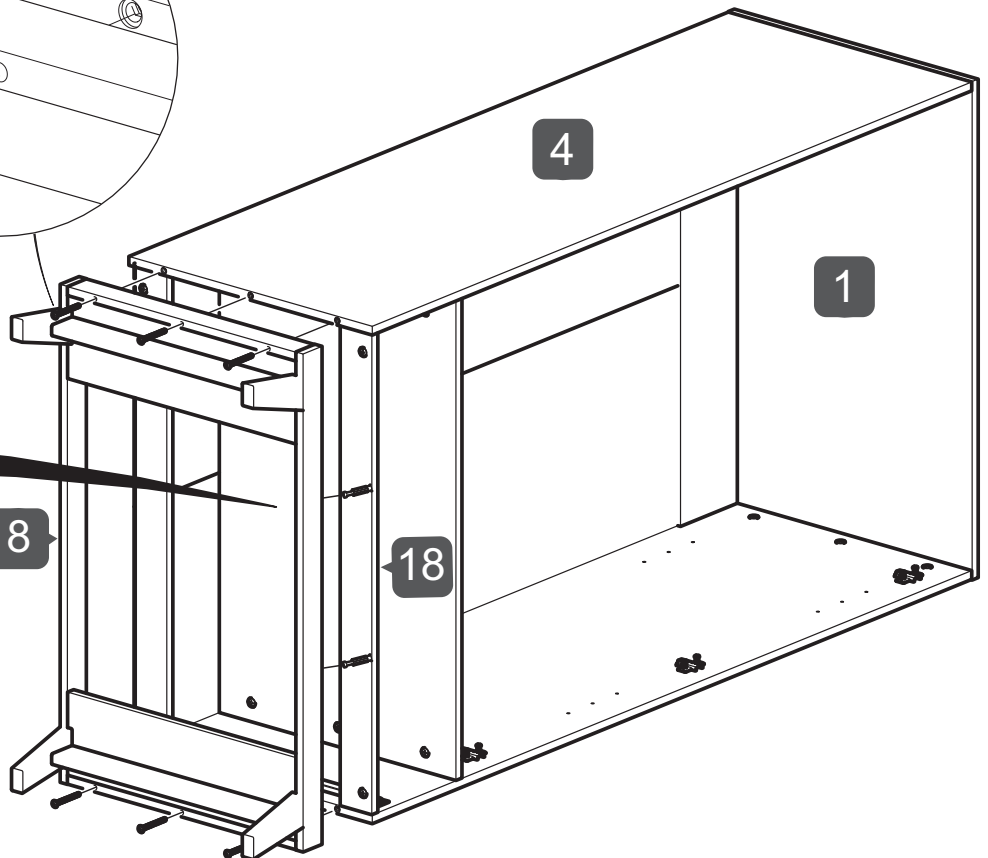
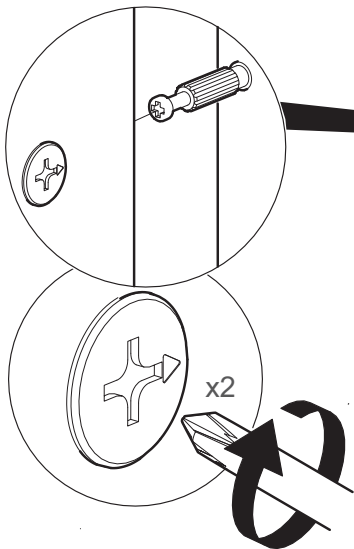
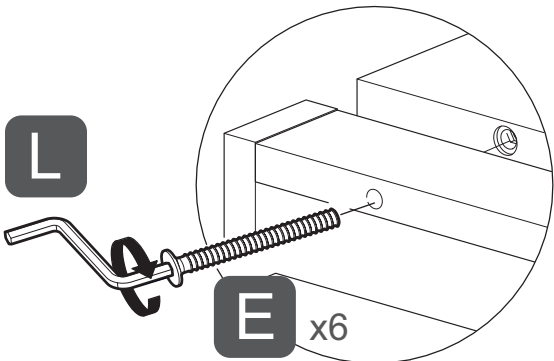
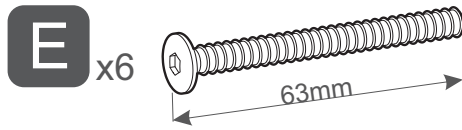
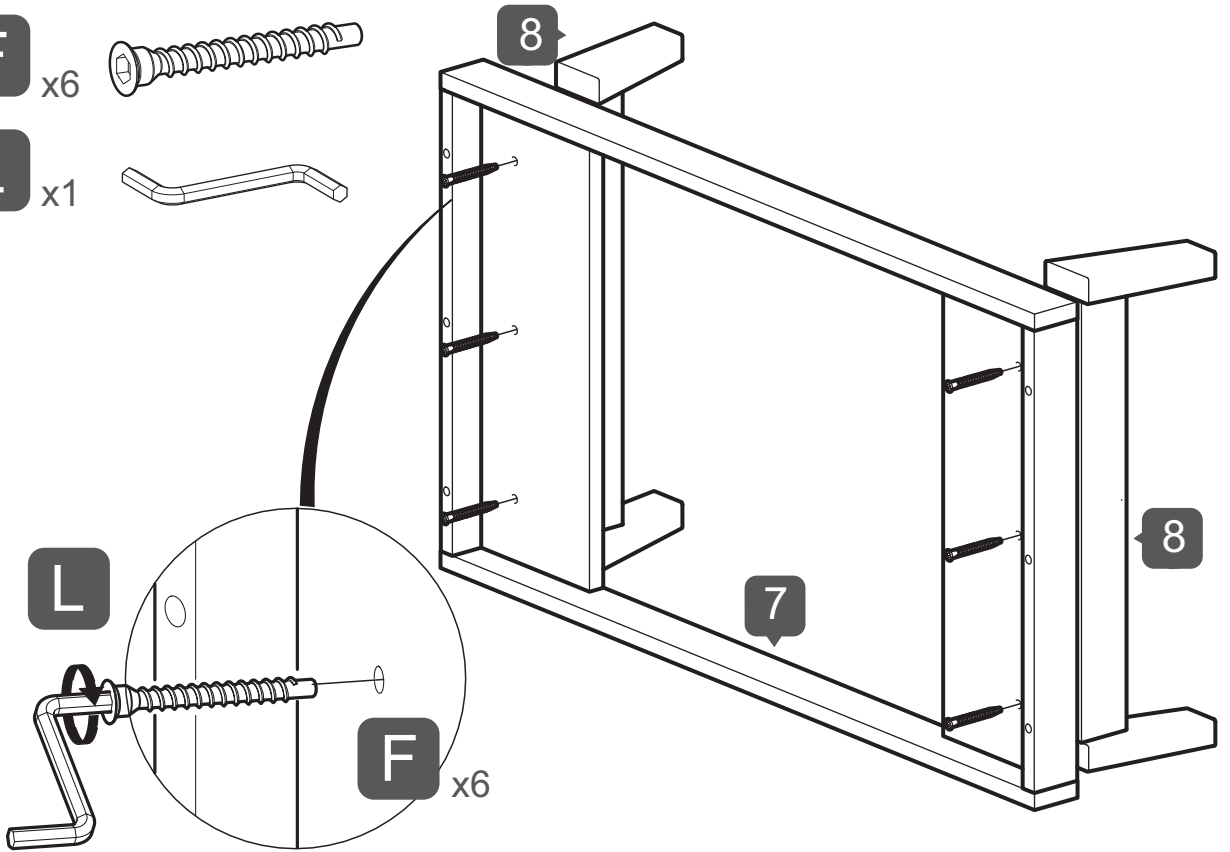
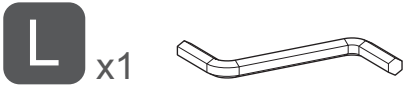
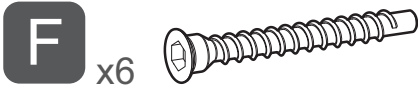

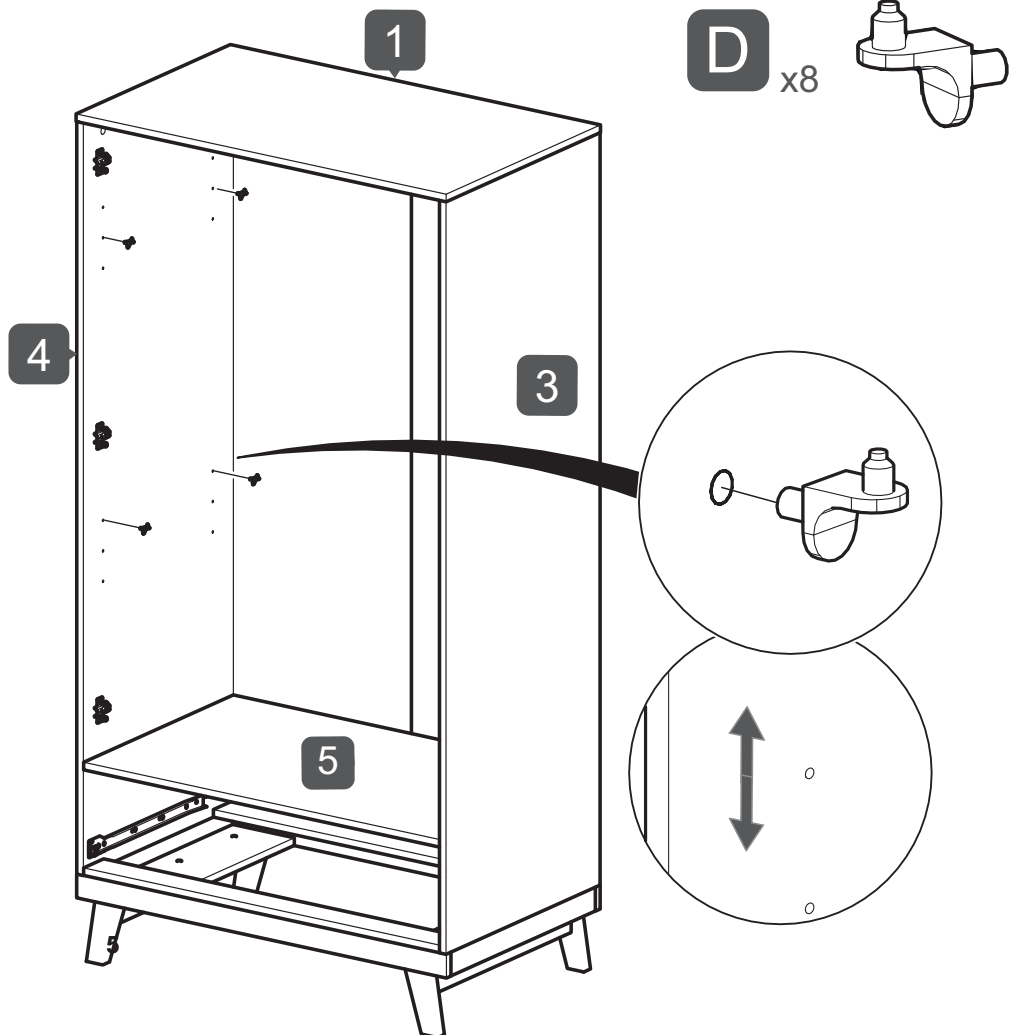
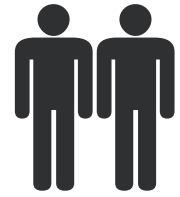
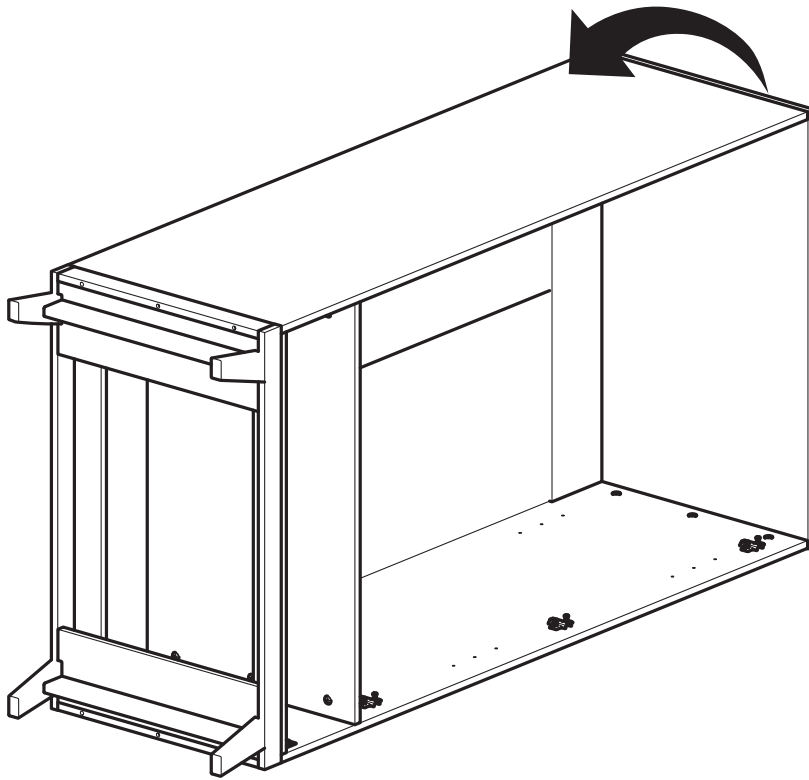

10

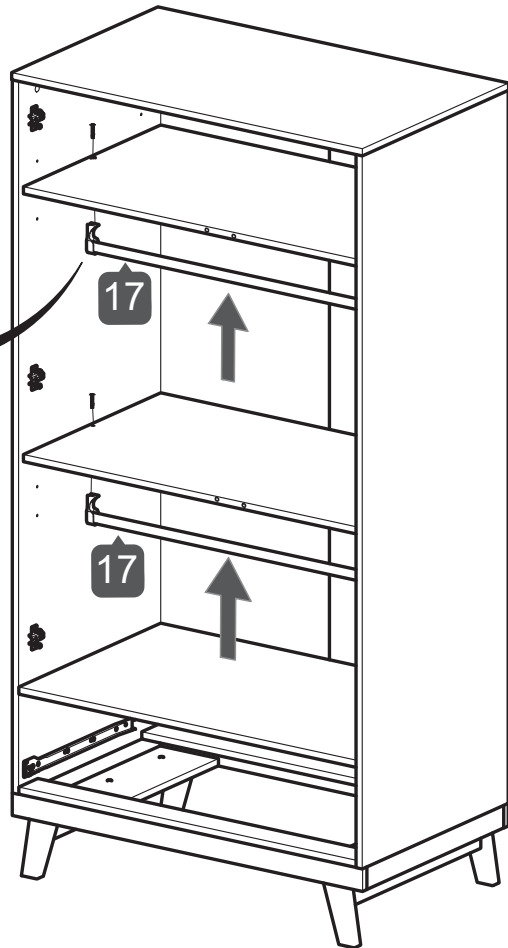
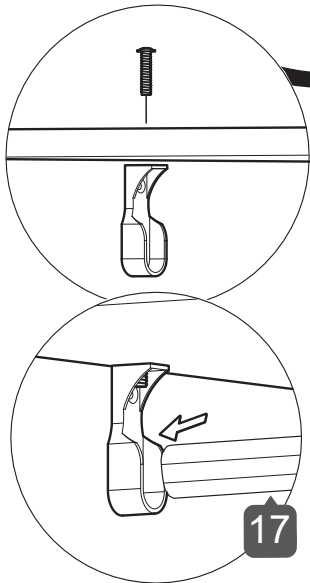
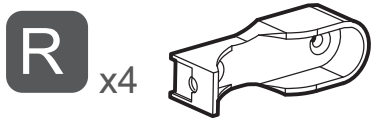
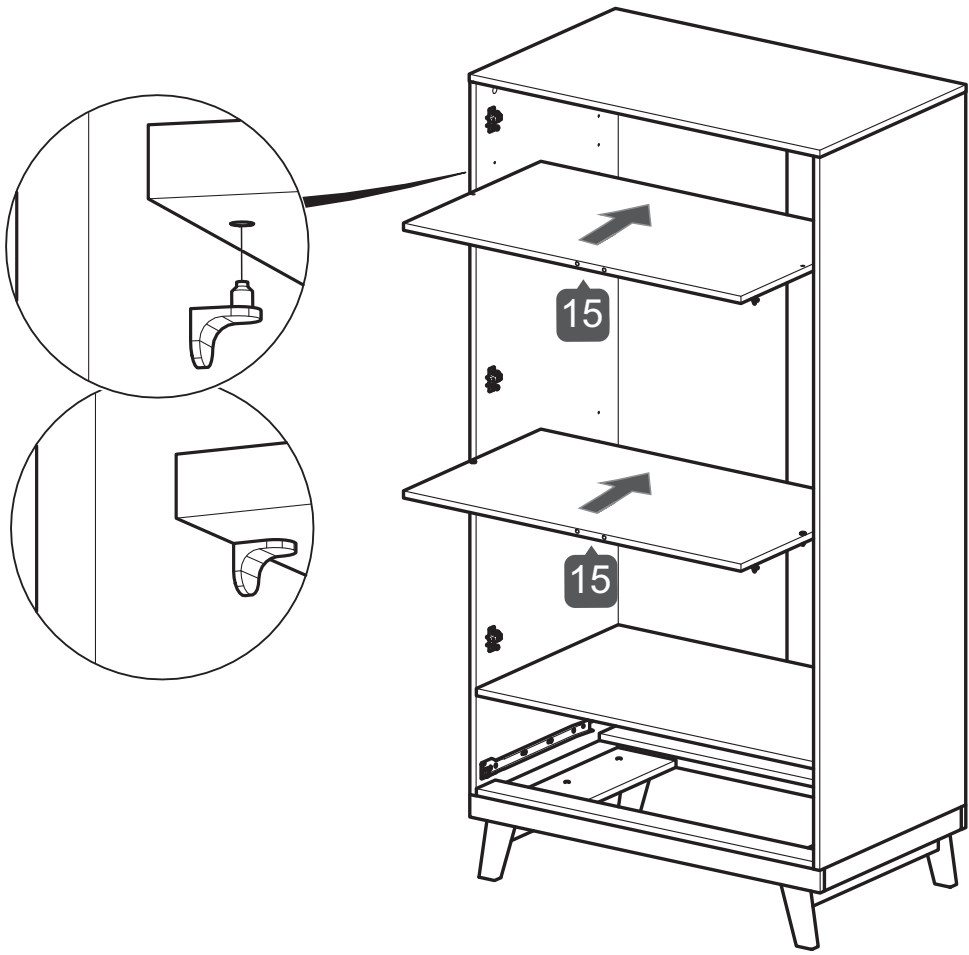



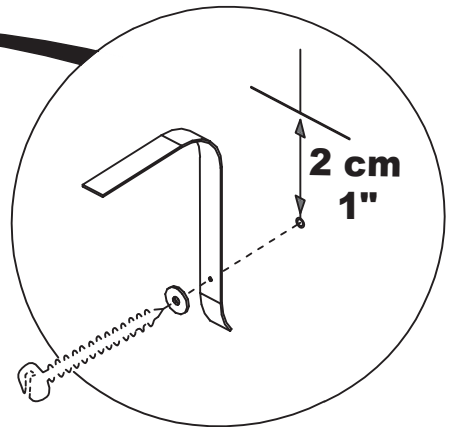
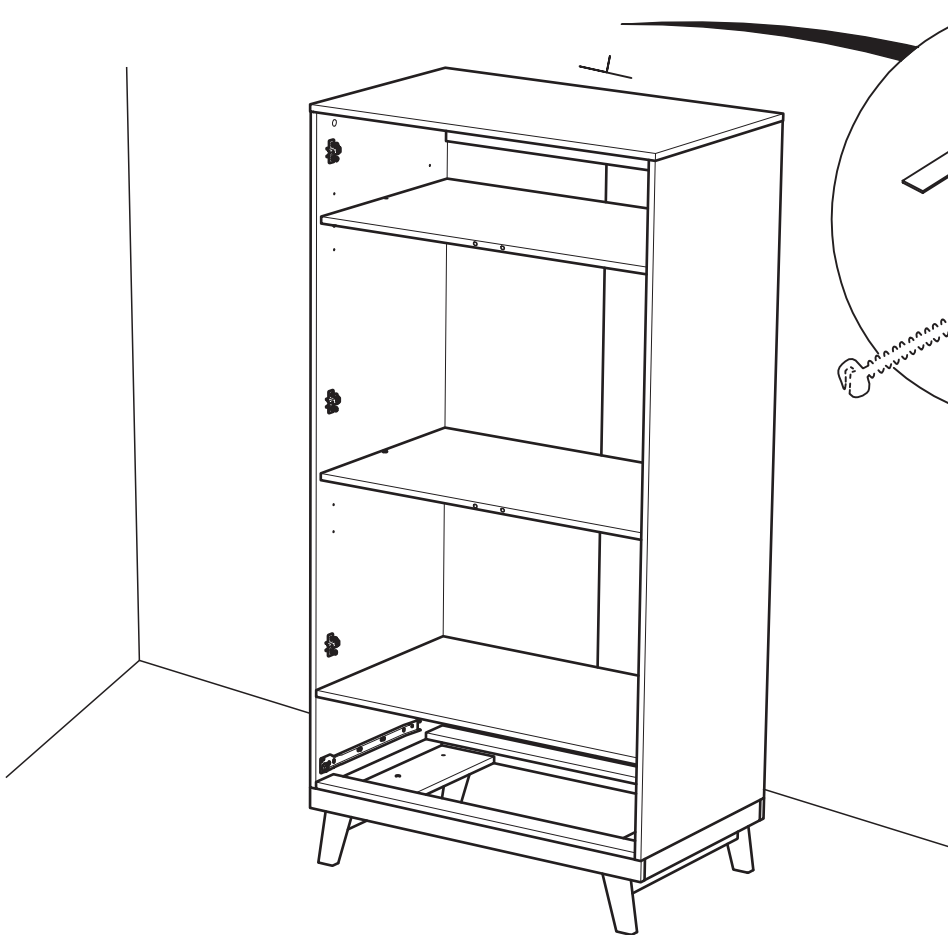
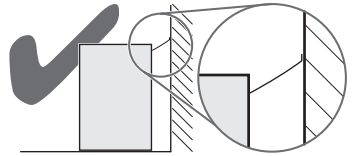
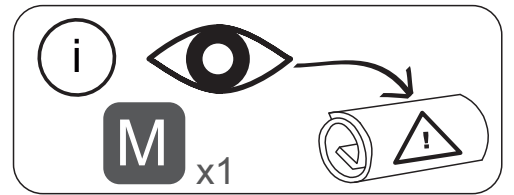
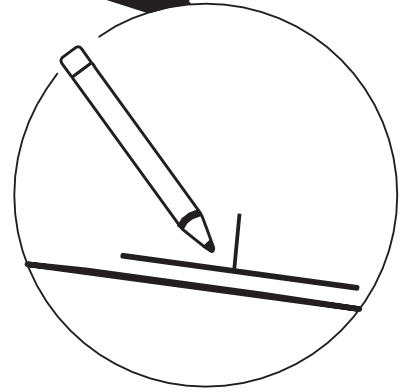
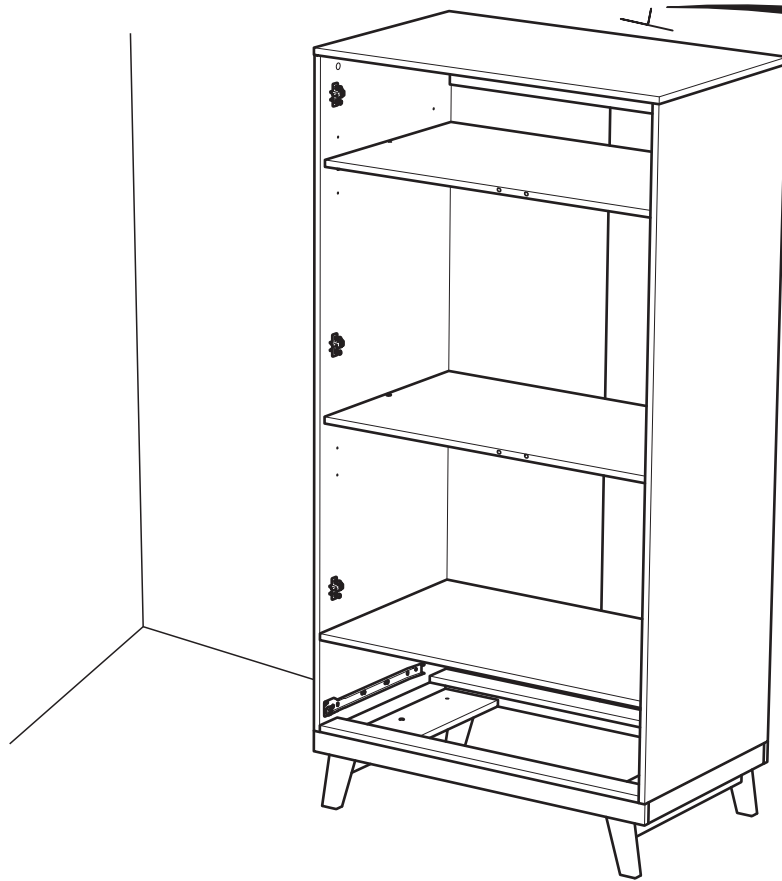

12

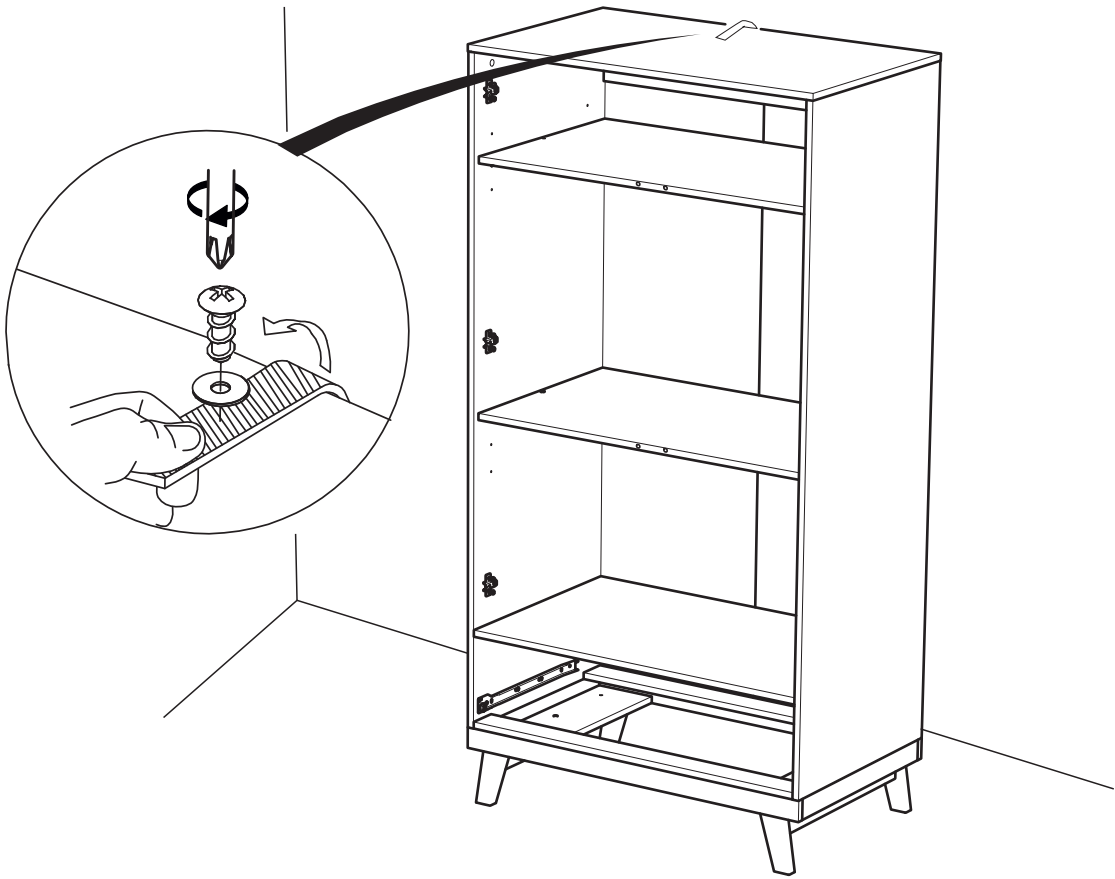

**i** x12

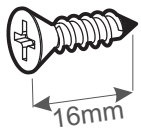

**N** x6

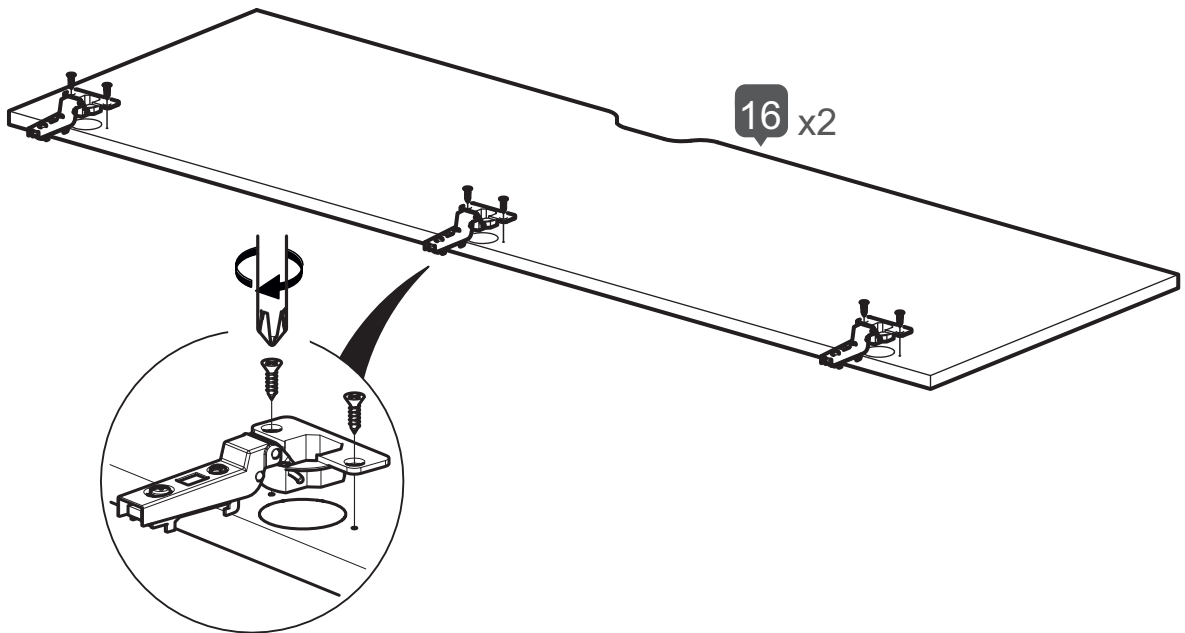
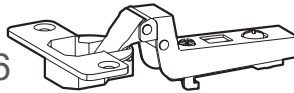

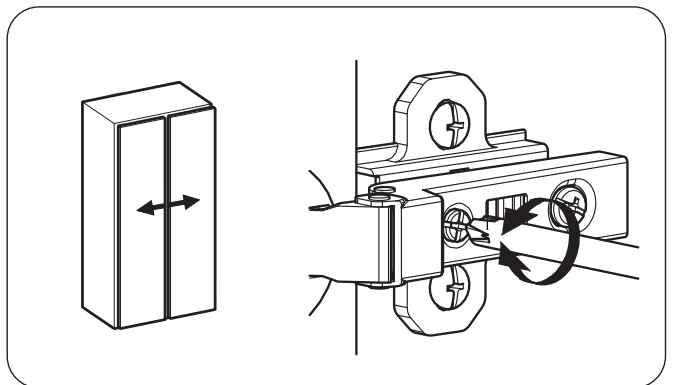
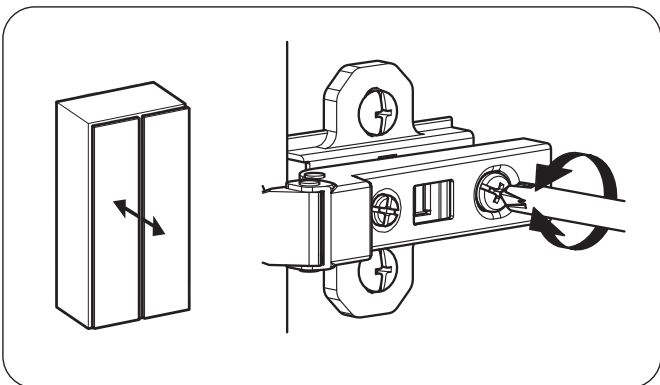
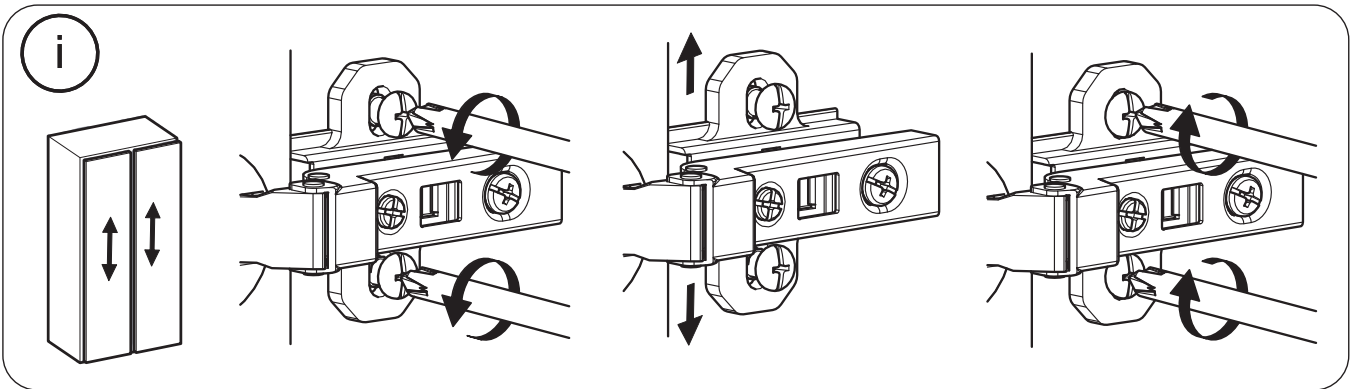
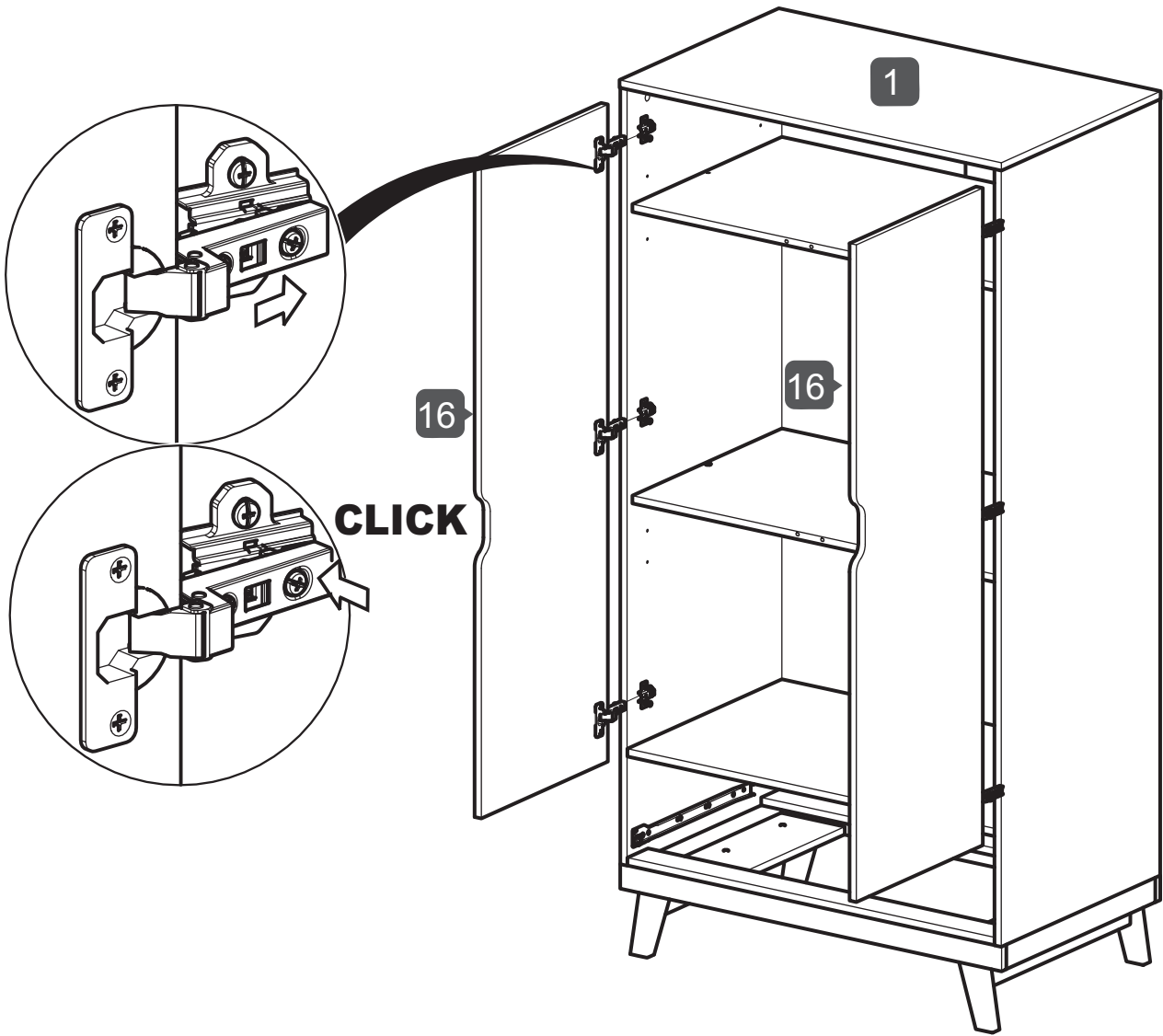

14

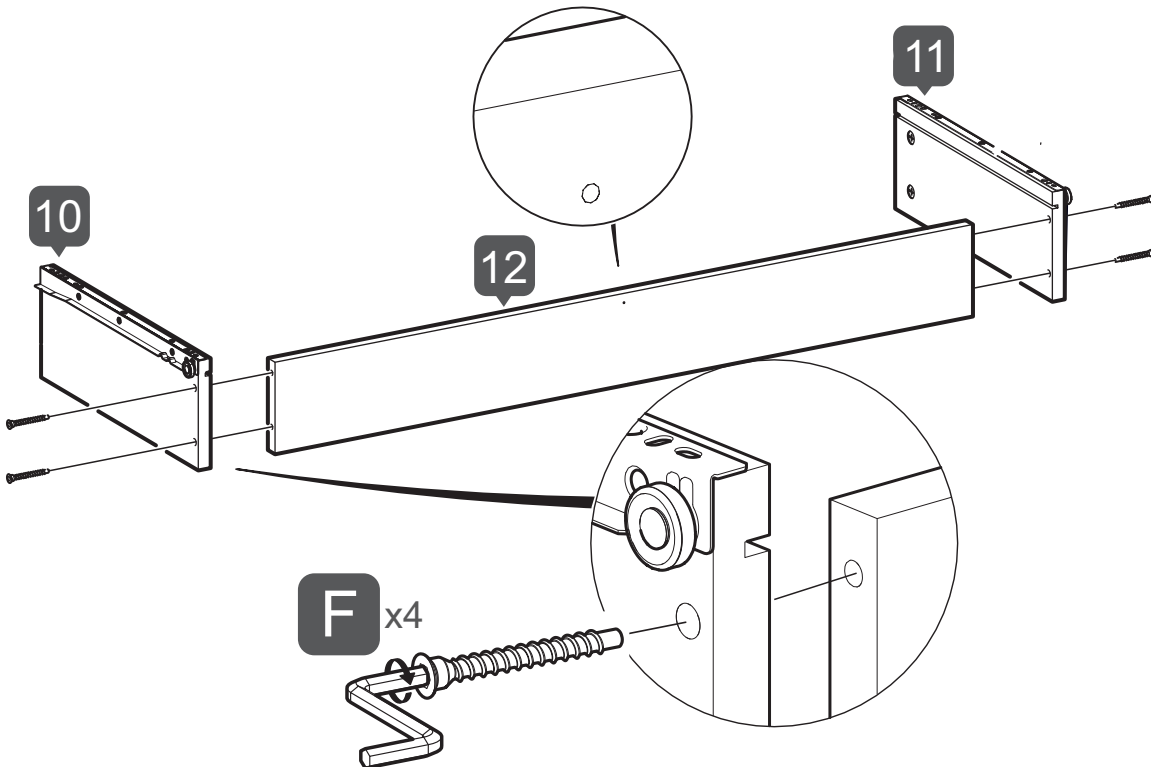
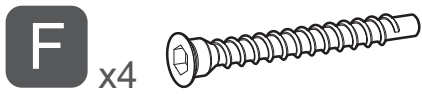
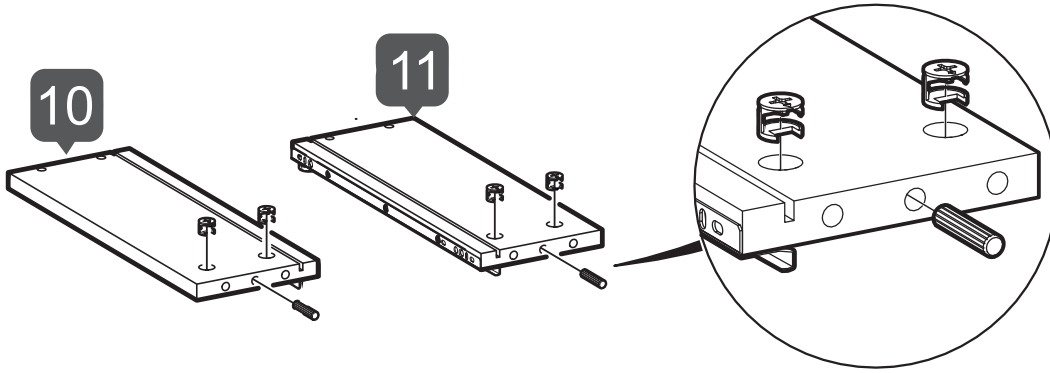

**A** x4

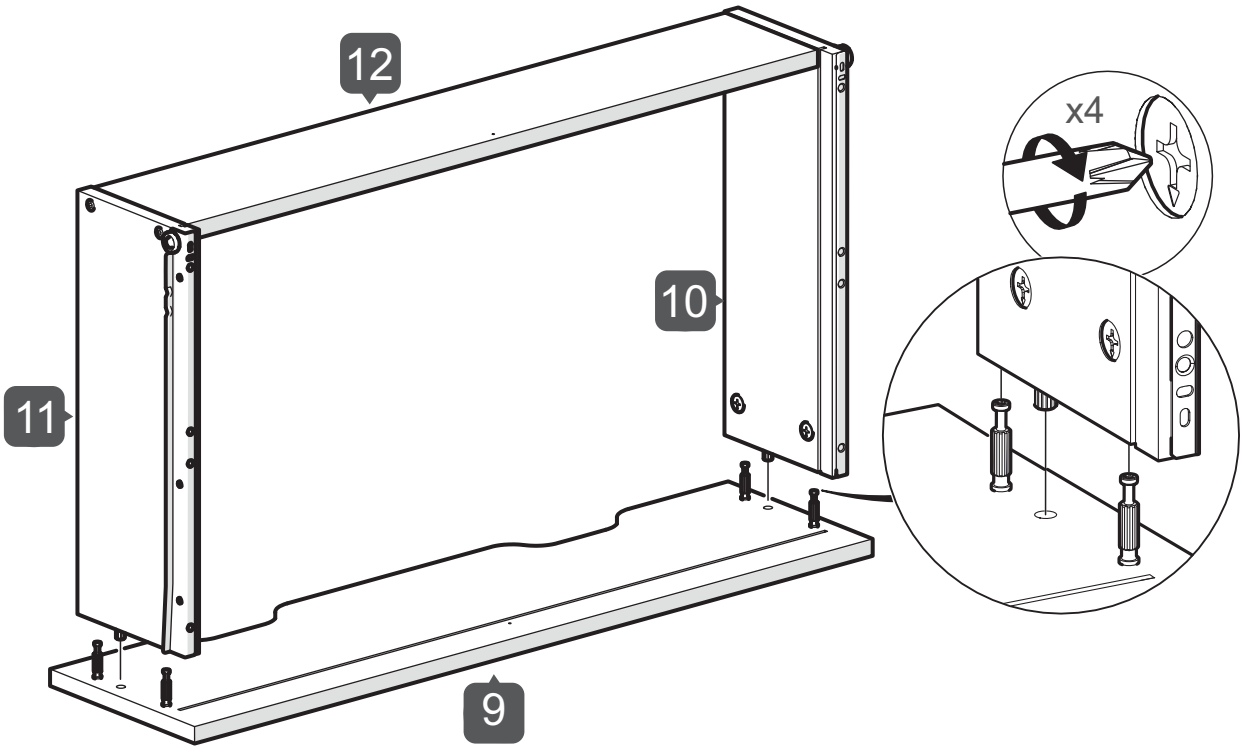
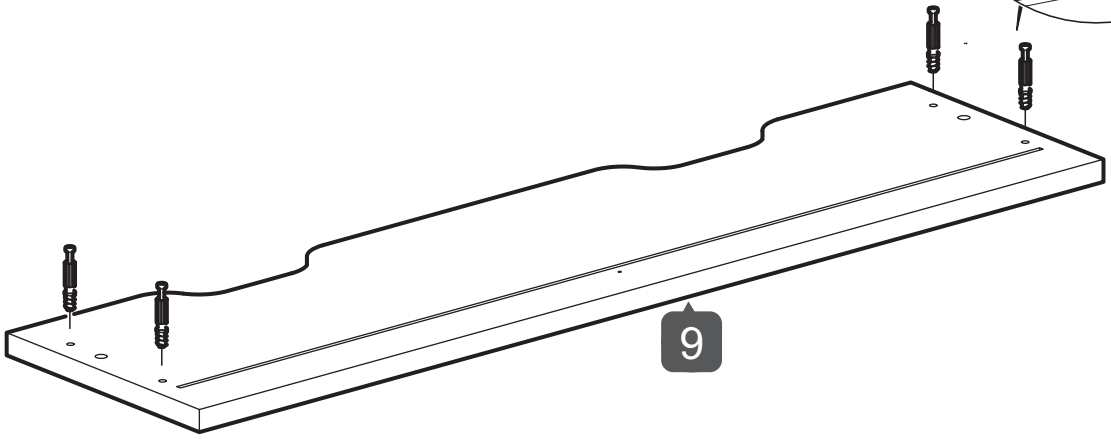
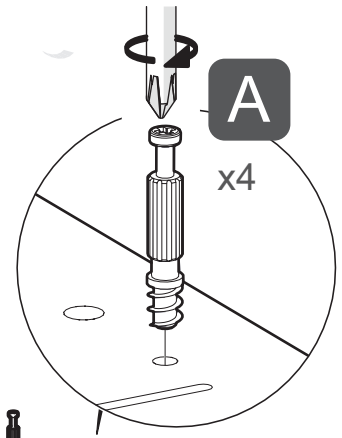
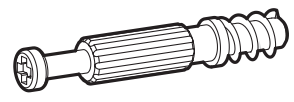

16

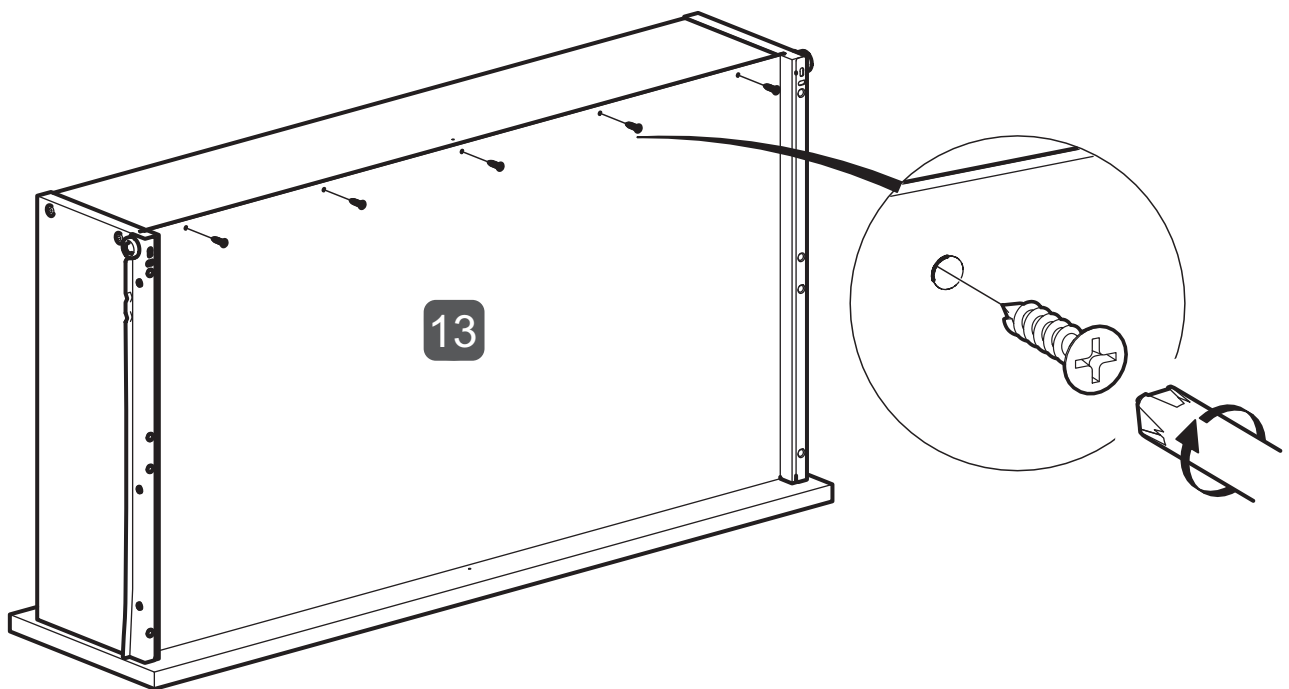
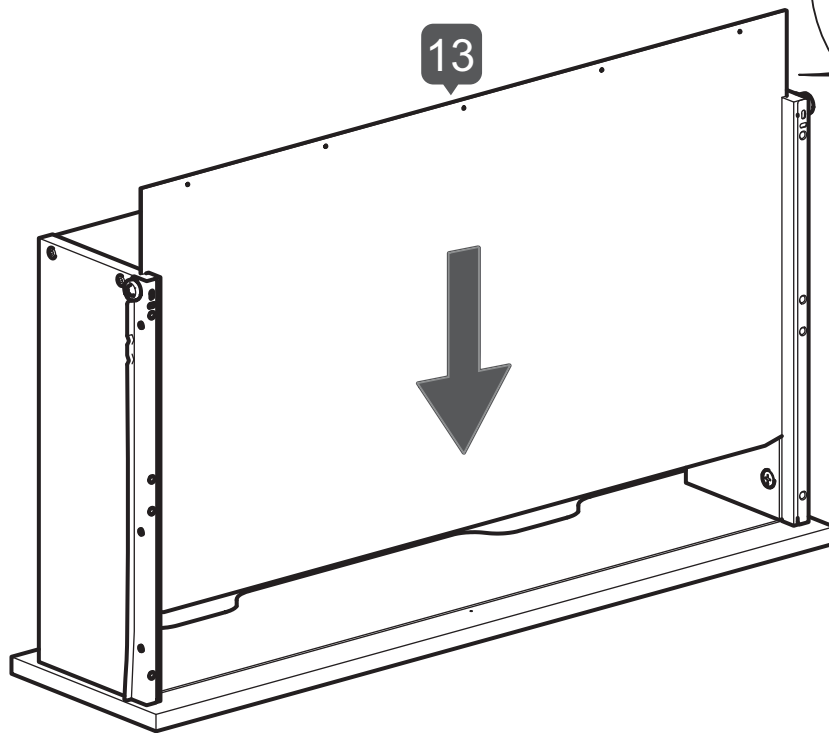

**H** x2



**K** x1

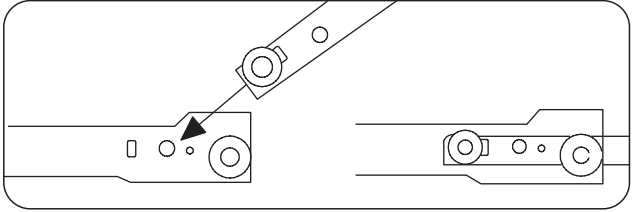
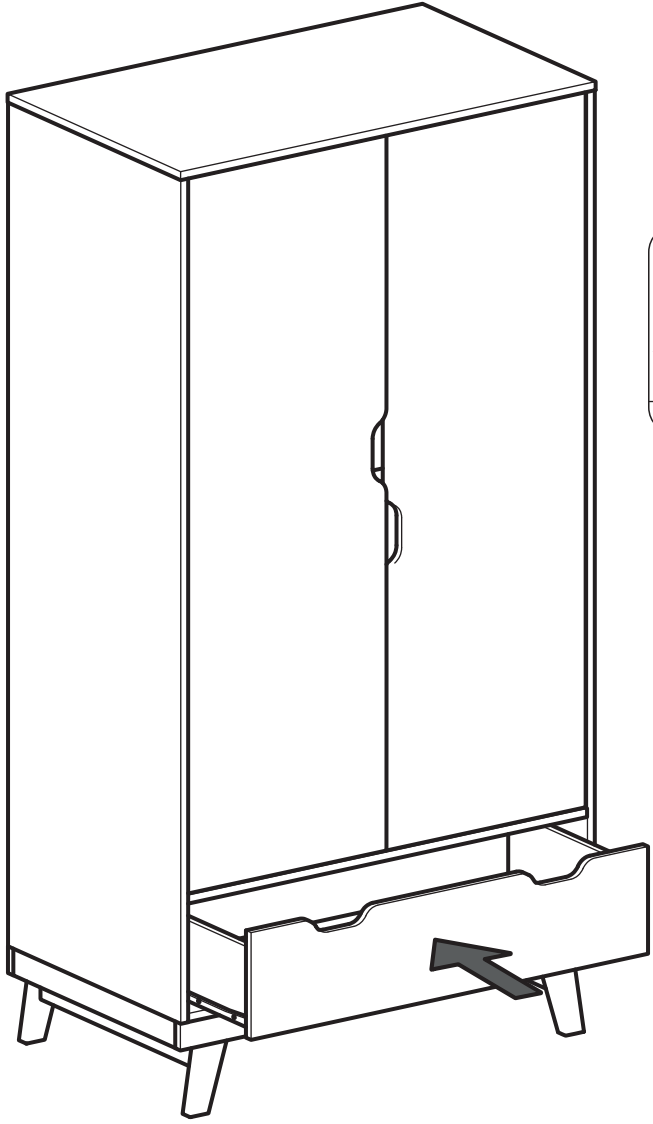
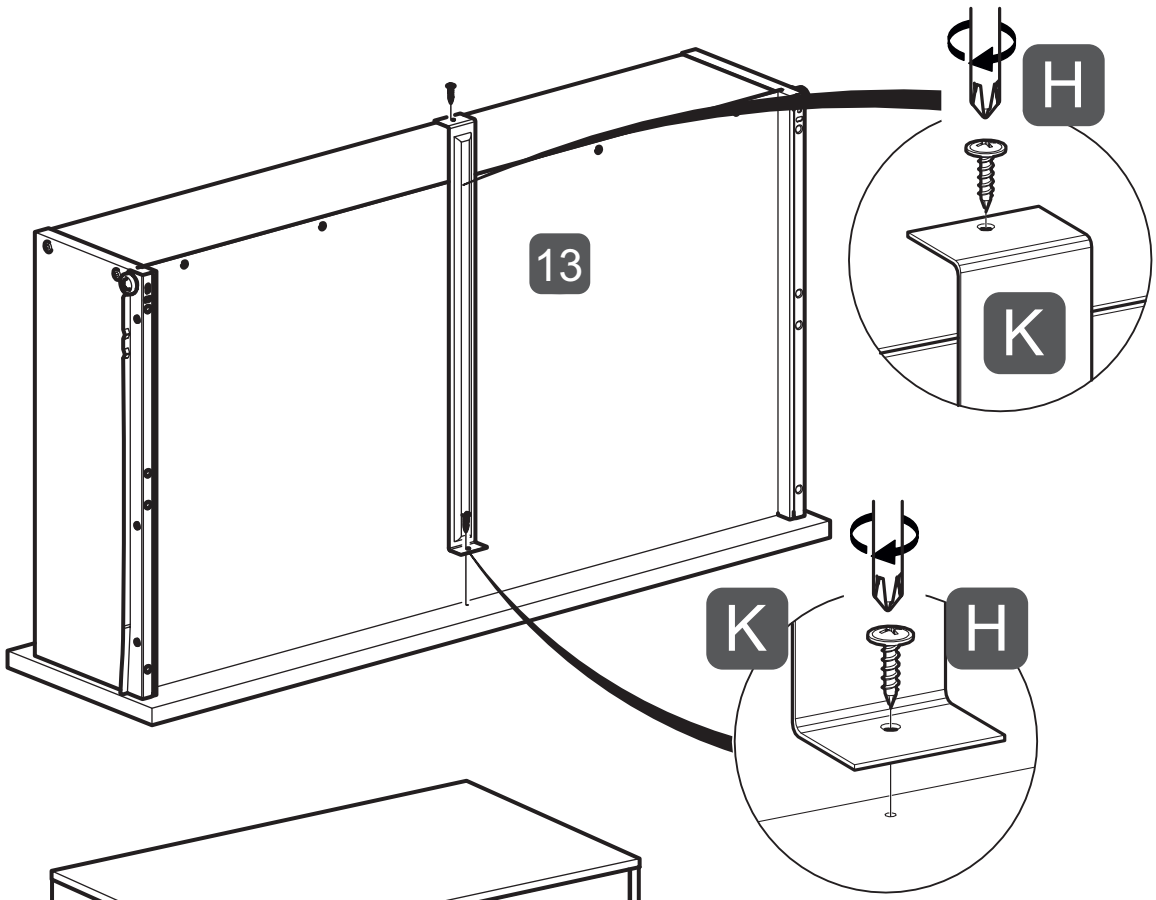

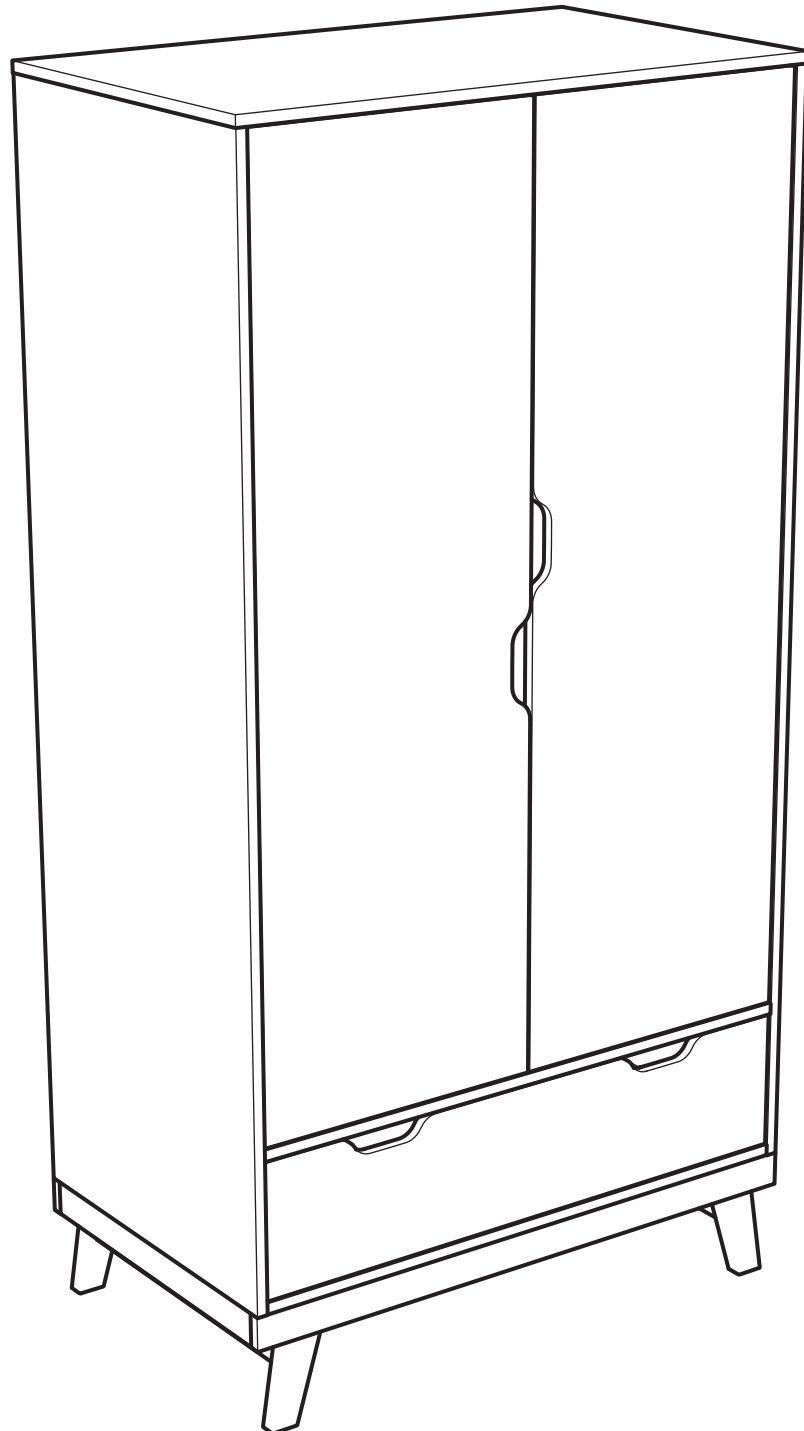

**Finished**

**Concluido**

**Fini**

**Fertig**

**Finito**

**Voltooid**



**UK****WALL STRAP INFORMATION**

- The wall strap is only intended to be used with the Mamas & Papas product that it is supplied with.
- Never attempt to modify or change the wall attachment strap in any way. Never use any other fittings for attaching the strap to your furniture than those supplied.
- Never use the screw provided to attach the strap to the wall. No wall attachment fittings are supplied. This is because the type of fittings required to attach the strap to the chosen wall is determined by the composition of the wall. If you are in any doubt about the correct type of fittings to use, consult a professional before attempting to attach the strap to the wall.
- The wall strap must not be used to replace any other fitting supplied with your piece of furniture.
- Furniture falling over is generally due to the surface the furniture is placed on. A warped floor or wall-to-wall carpeting will enable the furniture to rock, so greatly increasing the potential for the furniture to fall. If the furniture is placed on a flat level wood or tiled floor the risk is reduced, but we still recommend the wall strap is fitted.

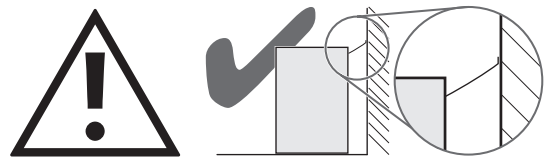
**FR****INFORMATIONS SUR LA SANGLE MURALE**

- La sangle murale est destinée à être exclusivement utilisée avec le produit Mamas & Papas avec laquelle elle est fournie.
- N'essayez jamais de modifier ou de changer la sangle de fixation murale de quelque façon que ce soit. N'utilisez jamais d'autres fixations pour fixer la sangle à vos meubles que celles fournies.
- N'utilisez jamais la vis fournie pour fixer la sangle au mur. La sangle n'est fournie avec aucune fixation murale. En effet, le type de fixation nécessaire pour fixer la sangle au mur choisi dépend de la composition du mur. En cas de doute quant au bon type de fixation à utiliser, consultez un professionnel avant d'essayer de fixer la sangle au mur.
- La sangle murale ne doit pas être utilisée pour remplacer toute autre fixation fournie avec votre meuble.
- Lorsqu'un meuble se renverse, cela est généralement dû à la surface sur laquelle il repose. Un sol ondulé ou de la moquette de mur à mur présente un risque que le meuble bascule, et donc augmente de beaucoup le risque que le meuble se renverse. Si le meuble repose sur un parquet ou un carrelage bien plat, le risque s'en trouve réduit de beaucoup, mais nous recommandons malgré tout d'utiliser la sangle murale.

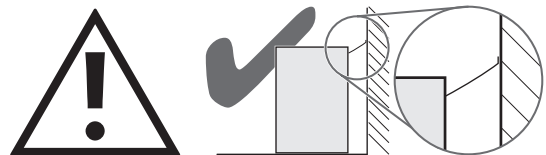
**ES****INFORMACIÓN SOBRE ANCLAJE A LA PARED**

- El anclaje a la pared ha sido diseñado para su uso exclusivo con el producto Mamas & Papas con el que ha sido suministrado.
- No intente modificar ni cambiar de modo alguno el anclaje de sujeción a la pared. No utilice ningún otro herraje diferente al que se suministra para sujetar el anclaje al mueble.
- Nunca utilice el tornillo que se suministra para sujetar el anclaje a la pared. No se suministran herrajes de sujeción. Esto se debe a que los tipos de anclajes necesarios para sujetar el anclaje a la pared elegida dependen de la composición de la pared en cuestión. Si tiene dudas sobre el tipo correcto de herrajes a utilizar, consulte a un profesional antes de intentar sujetar el anclaje a la pared.
- El anclaje no debe ser utilizado para sustituir a ningún otro herraje suministrado con el mueble.
- Cuando se produce la caída de un mueble, ésta se debe normalmente a la superficie sobre la que está colocado. Un suelo abombado o una moqueta de pared a pared permitirán que el mueble oscile incrementando con ello enormemente la posibilidad de que caiga. Si el mueble está colocado sobre un suelo llano de madera o baldosa se reduce el riesgo, pero aún en ese caso recomendamos la colocación del anclaje a la pared.

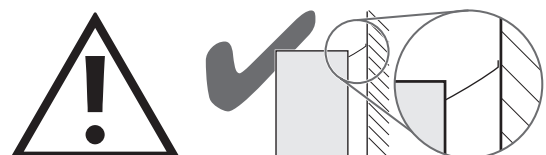

**D****HINWEISE FÜR EINE SICHERE VERWENDUNG**

- Der Wandriemen ist nur zur Verwendung mit dem von Mamas & Papas gelieferten Produkt vorgesehen.
- Versuchen Sie niemals, den Wandbefestigungsriemen in irgendeiner Weise zu verändern. Verwenden Sie nur die im Lieferumfang enthaltenen Befestigungen zum Anbringen des Riemen an Ihrem Möbelstück.
- Verwenden Sie niemals die vorhandenen Schrauben, um den Riemen an der Wand zu befestigen. Im Lieferumfang sind keine Wandbefestigungen enthalten. Der Grund hierfür ist, dass die Art der zum Anbringen des Riemen an der ausgewählten Wand benötigten Befestigungen von der Zusammensetzung der Wand abhängt. Sollten Sie in Bezug auf die zu verwendenden Befestigungen irgendwelche Zweifel haben, wenden Sie sich an einen Fachmann, bevor Sie versuchen, den Riemen an der Wand zu befestigen.
- Der Wandriemen darf nicht verwendet werden, um andere Befestigungen zu ersetzen, die im Lieferumfang Ihres Möbelstücks enthalten ist.
- Das Umstürzen von Möbelstücken ist im Allgemeinen auf die Oberfläche zurückzuführen, auf die die Möbelstücke gestellt wurden. Ein verzogener Boden oder ein von Wand zu Wand ausgelegter Teppich führt dazu, dass das Möbelstück schwankt, so dass das Umsturzrisiko erhöht ist. Steht das Möbelstück dagegen auf einem flachen, waagerechten Boden aus Holz oder Fliesen, ist das Risiko geringer. Wir empfehlen dennoch, den Wandriemen anzubringen.

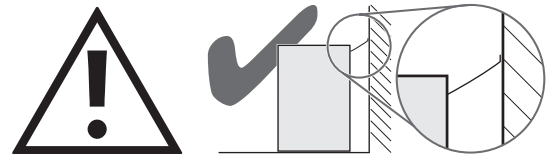
**IT****INFORMAZIONI SUL SUPPORTO DI FISSAGGIO A PARETE**

- Il supporto di fissaggio a parete deve essere utilizzato esclusivamente con il prodotto di Mamas & Papas insieme al quale viene fornito.
- Non tentare in nessun modo di modificare o manomettere il supporto di fissaggio a parete. Non usare in nessun caso attacchi diversi da quelli forniti per fissare il supporto al mobile.
- Non usare in nessun caso la vite fornita per fissare il supporto alla parete. La fornitura non comprende gli attacchi per il fissaggio a parete. Questo perché il tipo di attacchi richiesti per fissare il supporto alla parete prescelta dipende dalle caratteristiche della parete stessa. In caso di dubbi sul tipo corretto di attacchi da utilizzare, richiedere la consulenza di un professionista prima di tentare di fissare il supporto alla parete.
- Non usare il supporto di fissaggio a parete per sostituire altri attacchi forniti insieme al mobile.
- La caduta del mobile è solitamente causata dal tipo di superficie sulla quale questo viene posizionato. Un pavimento irregolare o interamente rivestito di moquette tenderà a bloccare il movimento del mobile, aumentando notevolmente le possibilità che questo cada o si rovesci. Qualora il mobile sia posizionato su un pavimento piano in legno o mattonelle, il rischio viene ridotto. Si raccomanda tuttavia il fissaggio alla parete tramite l'apposito supporto.

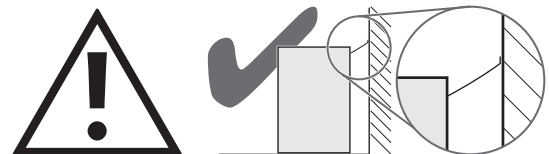
**NL****INFORMATIE WANDBEVESTIGINGSRIEM**

- De wandbevestigingsriem is uitsluitend bedoeld om te gebruiken met het product van Mamas & Papas waarbij het wordt geleverd.
- Probeer de wandbevestigingsriem op geen enkele wijze aan te passen of te veranderen. Gebruik geen andere bevestigingsmaterialen om de riem aan uw meubelstuk vast te maken dan degene die zijn geleverd.
- De geleverde schroef niet gebruiken om de riem aan de muur te bevestigen. Het product wordt geleverd zonder materialen om deze aan de muur te bevestigen. Dit is gedaan, omdat het soort bevestigingsmateriaal om de riem aan de muur te bevestigen, afhankelijk is van de samenstelling van de muur. Mocht u twijfelen over het juiste type bevestigingsmateriaal dat gebruikt moet worden, raadpleeg dan een deskundige voordat u probeert de riem aan de muur te bevestigen.
- De wandbevestigingsriem moet niet als vervanging worden gebruikt van andere bevestigingsmaterialen die bij een meubelstuk worden geleverd.
- Het omvallen van een meubelstuk heeft meestal te maken met de ondergrond waarop het meubelstuk is geplaatst. Door een kromgetrokken vloer of een kamerbrede vloerbedekking kunnen meubelstukken wiebelen, waardoor de mogelijkheid om om te vallen sterk wordt vergroot. Het risico is minder als het meubelstuk is geplaatst op een gelijke, vlakke houten of betegelde vloer, desondanks adviseren we de wandbevestigingsriem aan te brengen.

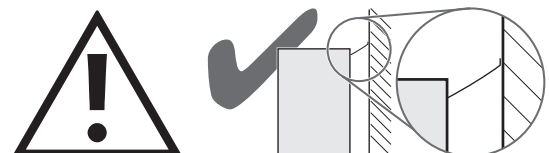

UK



## WARNING:

- DO NOT LEAVE THE CHILD UNATTENDED. The safety of your child is your responsibility
- In order to prevent overturning this product must be used with the wall attachment device provided
  
- Before use, ensure the product is on a stable, level surface.
- Do not allow children to climb on the product.
- Never use your product if any parts are broken or missing.
- Never pivot or drag your product. It must always be lifted by at least two people when being moved.
- Do not place your product in the near vicinity of open fires or other sources of strong heat, such as electric or gas fires.
- Always leave your product clean and dry. Wipe away any spillage straight away. Your product can be cleaned with a damp cloth. Never use abrasive, bleach or strong detergents.
- Check regularly that all fittings and screws are correctly tightened and are not damaged. Loose screws can pinch parts of the body and clothing resulting in the risk of strangulation.

ES



## ADVERTENCIA:

- NO DEJE SÓLO LA NIÑO. La seguridad de su hijo es su responsabilidad
- Para evitar vuelcos, este producto debe utilizarse con el accesorio para fijación a pared suministrado
- 
- Antes de usarlo, asegúrese de que el producto se halla sobre una superficie estable.
- No permita que los niños se suban a él.
- No utilice el producto si alguna de sus piezas está rota o falta.
- No haga girar nunca el producto sobre sus patas ni lo arrastre. Cuando desee moverlo, al menos dos personas deben elevarlo y transportarlo.
- No coloque el producto cerca de chimeneas u otras fuentes fuertes de calor, como por ejemplo, chimeneas eléctricas o de gas.
- Deje siempre el producto limpio y seco. En caso de que se derrame algún líquido, límpielo inmediatamente. Puede limpiarlo con un trapo húmedo. No utilice nunca limpiadores abrasivos, lejía ni detergentes fuertes.
- Compruebe con regularidad que todas las piezas y tornillos están apretados correctamente y se hallan en buen estado. Los tornillos sueltos pueden pellizcar partes del cuerpo y ropa, con riesgo de estrangulamiento

FR



## AVERTISSEMENT! / MISE EN GARDE!

- NE LAISSEZ PAS LA ENFANT SANS SURVEILLANCE. La sécurité de votre enfant relève de votre responsabilité.
- Afin d'éviter le retournement, ce produit doit être utilisé avec le dispositif de fixation au mur
- Avant d'utiliser le produit, assurez-vous qu'il se trouve sur une surface stable et horizontale.
- Ne laissez pas les enfants monter sur le produit.
- N'utilisez jamais le produit si une pièce est cassée ou manquante.
- Ne faites jamais pivoter le produit et ne le tirez pas. Il doit être toujours soulevé ou déplacé par au moins deux personnes.
- Ne placez pas le produit à proximité de flammes et d'autres sources de forte chaleur, telles que les appareils de chauffage électrique ou à gaz.
- Gardez toujours le produit propre et sec. Essuyez tout de suite tout liquide renversé. Ce produit peut être nettoyé à l'aide d'un chiffon humide. N'utilisez jamais de produits abrasifs ni de détergents concentrés ni d'eau de Javel.
- Vérifiez régulièrement si toutes les pièces de fixation et les vis sont serrées correctement et en bon état. Les vis desserrées risquent de pincer des parties du corps et les vêtements, ce qui entraîne un risque d'étranglement.

D



## WARNUNG:

- LASSEN SIE DAS KIND NIEMALS UNBEAUF SICHTIGT. Für die Sicherheit Ihres Kindes sind SIE verantwortlich.
- Um ein Umkippen zu vermeiden muss dieses Produkt mit der zur Verfügung gestellten Wandbefestigung verwendet werden
- Stellen Sie vor der Verwendung sicher, dass sich das Produkt auf einer stabilen, waagerechten Oberfläche befindet.
- Lassen Sie Ihr Kind nicht auf das Produkt klettern.
- Verwenden Sie das Produkt nicht, wenn Teile defekt sind oder fehlen.
- Das Produkt darf nicht gedreht oder gezogen werden. Zum Transportieren muss es immer von mindestens zwei Personen angehoben werden.
- Stellen Sie Ihr Produkt nicht in der unmittelbaren Nähe von offenem Feuer oder anderen intensiven Wärmequellen - wie z. B. Elektro- oder Gasöfen - auf.
- Achten Sie darauf, dass Ihr Produkt immer sauber und trocken ist. Verschüttete Flüssigkeiten müssen immer sofort abgewischt werden. Ihr Produkt kann mit einem feuchten Tuch gereinigt werden. Verwenden Sie niemals Bleich- oder Scheuermittel oder starke Reinigungsmittel.
- Überprüfen Sie regelmäßig, dass die Befestigungen und Schrauben korrekt angezogen und unbeschädigt sind. An lockeren Schrauben können Körperteile und Kleidung hängenbleiben und ein Strangulationsrisiko darstellen.

IT



## AVVERTENZA:

- NON LASCIARE IL BAMBINO INCUSTODITO. Il genitore è responsabile della sicurezza del bambino.
- Per impedire che si ribalti, questo prodotto deve essere usato con il dispositivo per attacco a parete fornito.
- Prima dell'uso, verificare che il prodotto sia in posizione stabile e orizzontale.
- Non consentire al bambino di arrampicarsi.
- Non usare mai il prodotto qualora vi fossero componenti mancanti o danneggiati.
- Non ruotare mai o trascinare il prodotto. Sollevarlo sempre con l'aiuto di almeno un'altra persona per spostarlo.
- Non posizionare il prodotto nelle vicinanze di fiamme o altre fonti di calore quali radiatori, fornelli elettrici o a gas.
- Mantenere sempre il prodotto pulito e asciutto. Eliminare immediatamente eventuali liquidi. Pulire con un panno umido. Non applicare mai sbiancanti o detergenti abrasivi.
- Verificare regolarmente che tutti gli attacchi e le viti siano correttamente serrati e in buone condizioni. Le viti allentate possono provocare lesioni sul corpo e sui vestiti del bambino, con il rischio di strangolamento.

NL



## WAARSCHUWING:

- LAAT UW KIND NIET ZONDER TOEZICHT ACHTER. De veiligheid van uw kind is uw verantwoordelijkheid.
- Om te voorkomen dat dit product omkantelt, moet het worden gebruikt met de bijgeleverde muurbevestiging.
- Plaats het product voor gebruik op een stabiele, gelijke ondergrond.
- Laat kinderen niet op het product klimmen.
- Gebruik het product niet als een onderdeel is gebroken of ontbreekt.
- Het product niet om de spil draaien of verslepen. Gebruik bij het verplaatsen van het product altijd minstens twee personen om het op te tillen.
- Plaats het product niet in de buurt van open vuur of andere sterke hittebronnen, zoals elektrische kachels of gaskachels.
- Laat het product altijd schoon en droog achter. Als er op het product gemorst is, maak het dan meteen schoon. Het product kan met een vochtige doek worden afgenomen. Gebruik geen schuur- of bleekmiddelen of andere sterke schoonmaakmiddelen.
- Controleer regelmatig of alle onderdelen en schroeven stevig en goed bevestigd zijn en niet zijn beschadigd. Door losse schroeven kunnen delen van het lichaam en kleding bekneld raken met als gevolg het risico van wurging.









---

HD5 0RH, UK

---

 [mamasandpapas.com](http://mamasandpapas.com)  
[mamasandpapas.ca](http://mamasandpapas.ca)  
[mamasandpapas.kr](http://mamasandpapas.kr)

---

 **UK** T: +44 (0)345 268 2000  
**USA** T: 1-800-490-0331  
**CAN** T: 1-800-667-4111

---

 [/mamasandpapasuk](https://www.facebook.com/mamasandpapasuk)  
[/mamasandpapasusa](https://www.facebook.com/mamasandpapasusa)  
[/mamasandpapasmaltairegion](https://www.facebook.com/mamasandpapasmaltairegion)  
[/mamasandpapasmagyarorszag](https://www.facebook.com/mamasandpapasmagyarorszag)

---

 [@mamasandpapas](https://twitter.com/mamasandpapas)

---

 [/user/mamasandpapasglobal](https://www.youtube.com/user/mamasandpapasglobal)

---

 [mamasandpapasblog.com](http://mamasandpapasblog.com)

---

 [/mamasandpapas](https://www.instagram.com/mamasandpapas)

---

 [/mamasandpapasuk](https://www.pinterest.com/mamasandpapasuk)  
[/mamasandpapasus](https://www.pinterest.com/mamasandpapasus)

---

 [/+mamasandpapas](https://plus.google.com/+mamasandpapas)

---

┌ LOT ┐  
└ ┘

---

---