

**Thank you for ordering from
Mamas & Papas.**

For over 30 years, we have been committed to creating a world of quality, individuality and style for parents around the world. At the very beginning we were inspired by our daughters — now we see them all grown up, with children of their own, helping us to share our passion for parenting to their generation of Mums and Dads. We hope you enjoy exploring our new collection and wish you a very warm welcome to our world.

We are committed to designing and developing products to the highest standards, for your family to enjoy and we welcome any feedback or comments you may have.

The Mamas & Papas Family.

**Gracias por elegir
Mamas & Papas.**

Durante más de 30 años, nuestro compromiso ha sido crear un mundo de calidad, individualidad y estilo para padres de todo el mundo. Al principio nos inspiraron nuestras propias hijas, que ahora son adultas y tienen sus propios hijos, y nos ayudan a compartir nuestra pasión por la paternidad con su generación de mamás y papás. Esperamos que disfruten descubriendo nuestra nueva colección y les damos una calurosa bienvenida a nuestro mundo.

Nos comprometemos a diseñar y elaborar productos de la mejor calidad, con el fin de que su familia los disfrute y nosotros recibamos las respuestas y comentarios que le puedan surgir.

La Familia Mamas & Papas.

**Merci d'avoir choisi
Mamas & Papas.**

Cela fait plus de 30 années que nous nous consacrons à créer un monde de qualité, d'individualité et de style pour les parents dans le monde entier. Au tout début, nous étions inspirés par nos filles — à présent celles-ci ont grandi, elles ont des enfants aussi et nous aident à partager avec vous notre passion de création en nous adressant à leur génération de mamans et de papas. Nous espérons que vous passerez un agréable moment à découvrir notre nouvelle collection et nous sommes heureux de vous accueillir dans notre monde.

Nous nous engageons à concevoir et à développer des produits de la plus haute qualité, pour le plaisir de votre famille et nous serions heureux de recevoir vos réactions et observations éventuelles.

La Famille Mamas & Papas.

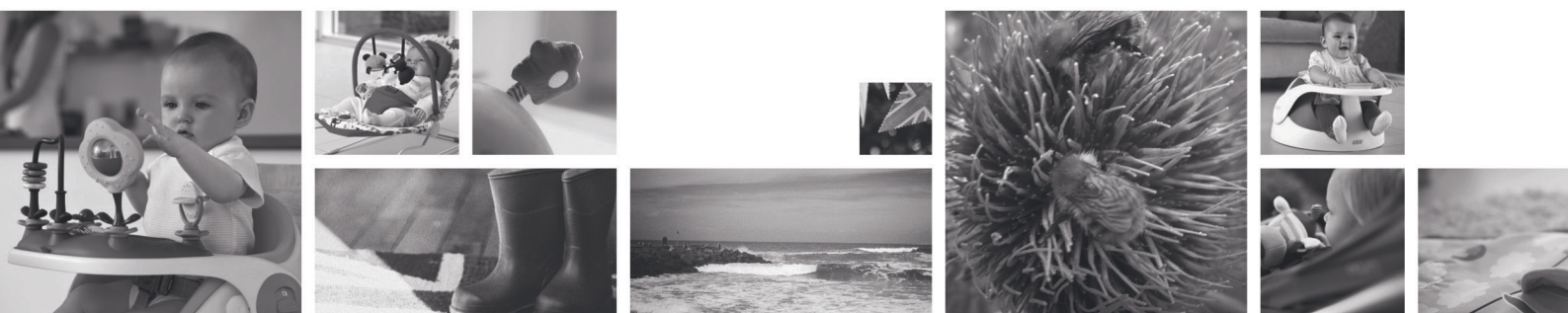

für Mamas & Papas entschieden haben.

Seit über 30 Jahren entwickeln wir mit großem Engagement für Eltern in aller Welt Produkte, die für Qualität, Individualität und Stil stehen. Die erste Inspiration gaben uns unsere Töchter, die mittlerweile erwachsen sind, selbst Kinder haben und uns nun dabei helfen, die Mütter und Väter ihrer Generation mit unserer Begeisterung für Babyprodukte anzustecken. Wir hoffen, dass es Ihnen Spaß machen wird, sich unsere neue Kollektion anzusehen, und heißen Sie herzlich willkommen in unserer Welt.

Wir haben es uns zur Aufgabe gemacht, Produkte auf höchstem Niveau zu entwerfen, die Ihre Familie genießen kann. Daher freuen wir uns immer über Ihr Feedback oder Ihre Kommentare.

Die Mamas & Papas-Familie.

Grazie per aver scelto Mamas & Papas.

Da oltre 30 anni lavoriamo per creare un mondo di qualità, unicità e stile per i genitori di tutto il mondo. All'inizio abbiamo tratto ispirazione dalle nostre figlie; adesso che sono cresciute e hanno a loro volta dei figli, ci aiutano a far conoscere alla loro generazione di mamme e papà la nostra passione nel vivere l'esperienza di genitori. Ci auguriamo che apprezzerete la nostra nuova collezione e vi diamo un caloroso benvenuto nel nostro mondo

Il nostro impegno è quello di progettare e realizzare prodotti rispondenti agli standard più elevati per la vostra famiglia e saremo lieti di ricevere suggerimenti o commenti da parte vostra.

La famiglia di Mamas & Papas.

Hartelijk dank dat u voor een product van Mamas & Papas heeft gekozen.

Al meer dan 30 jaar zetten wij ons in om een wereld van kwaliteit, individualiteit en stijl te scheppen voor ouders verspreid over de hele aardbol. In het begin werden we geïnspireerd door onze eigen dochters. Nu die volwassen zijn en zelf kinderen hebben, helpen zij ons onze passie voor ouderschap te delen met vaders en moeders van hun eigen generatie. We hopen dat u onze nieuwe collectie met plezier zult verkennen en heten u van harte welkom in onze wereld.

Wij hopen dat u met uw gezin van onze producten zult genieten en mocht u feedback willen geven of andere opmerkingen hebben, dan horen we graag van u.

De Mamas & Papas Familie.



EN **IMPORTANT!**
RETAIN FOR FUTURE REFERENCE:
READ CAREFULLY

ES **¡IMPORTANTE!**
LEA ESTAS INSTRUCCIONES DETENIDAMENTE Y
GUÁRDELAS PARA FUTURA REFERENCIA

FR **IMPORTANT !**
VEUILLEZ LIRE CES CONSIGNES AVEC ATTENTION
ET LES CONSERVER POUR VOUS Y REPORTER
ULTÉRIEUREMENT

D **ACHTUNG!**
BITTE LESEN SIE SICH DIESE ANWEISUNGEN
SORGFÄLTIG DURCH UND BEWAHREN SIE SIE FÜR
ZUKÜNFTIGE VERWENDUNG AUF

IT **IMPORTANTE!**
LEGGERE ATTENTAMENTE QUESTE ISTRUZIONI E
CONSERVARLE COME RIFERIMENTO FUTURO

NL **BELANGRIJK!**
BEWAAR VOOR TOEKOMSTIGE REFERENTIE:
LEES DIT ZORGVULDIG DOOR

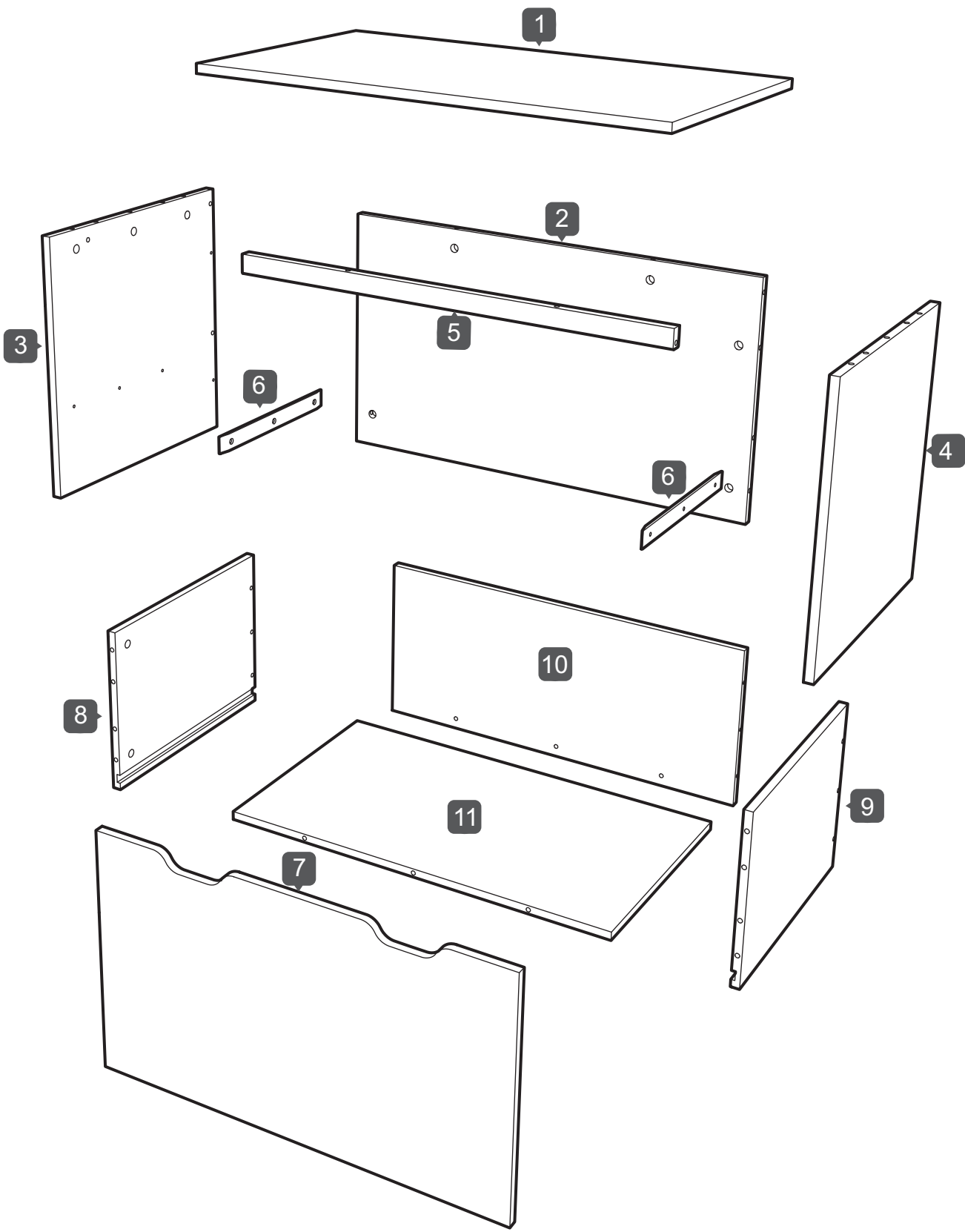

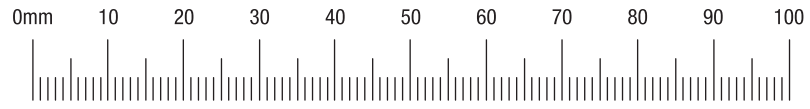

A

x19

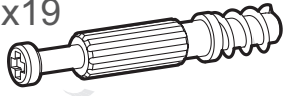

B

x19

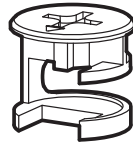

C

x16

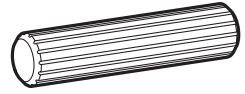

D

x4

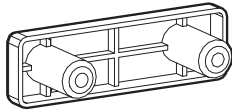

E

x16



F

x9

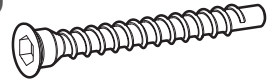

G

x6



H

x2

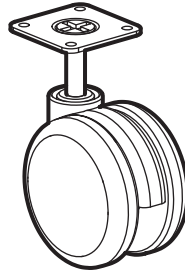

i

x2

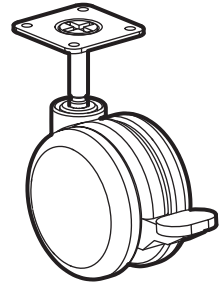

J

x1



A x4

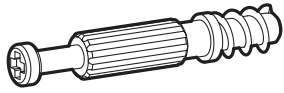

B x6

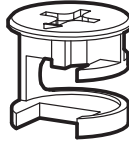

C x4

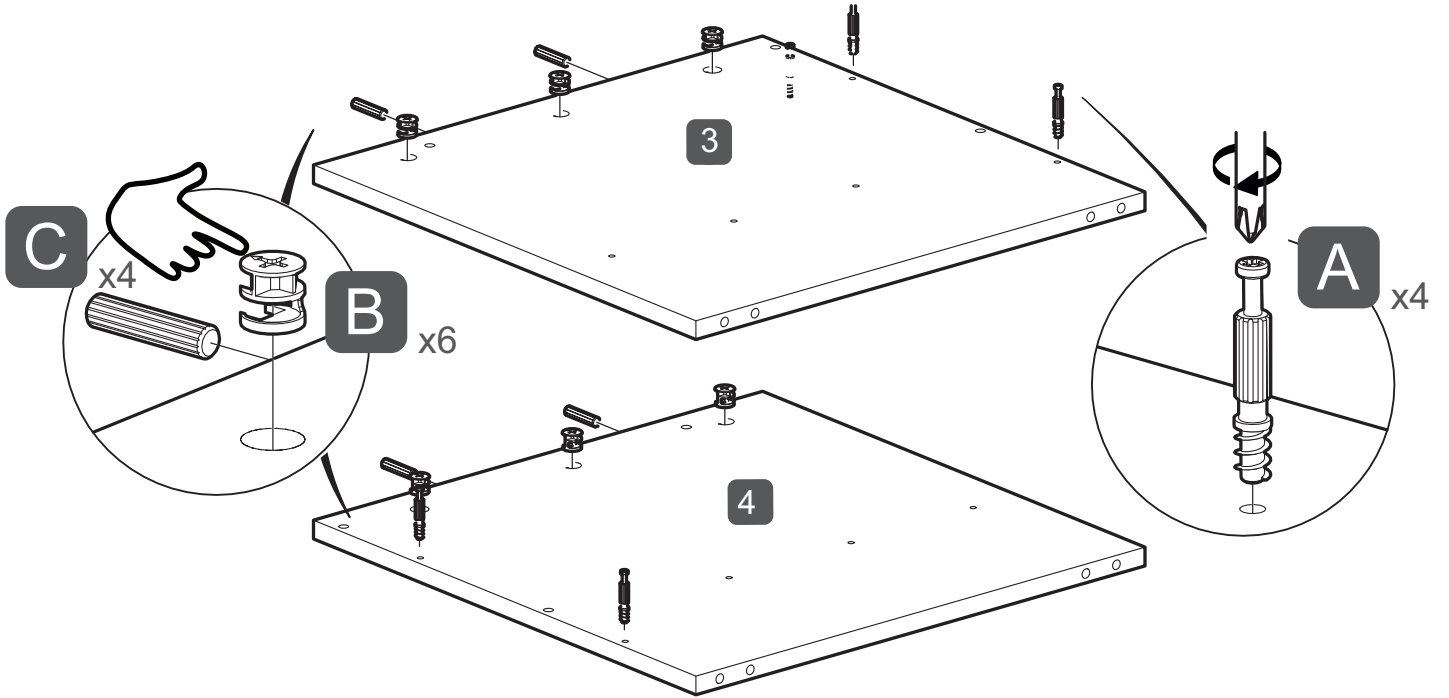
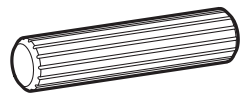

D x4

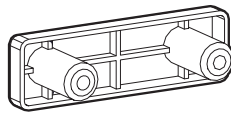

G x6

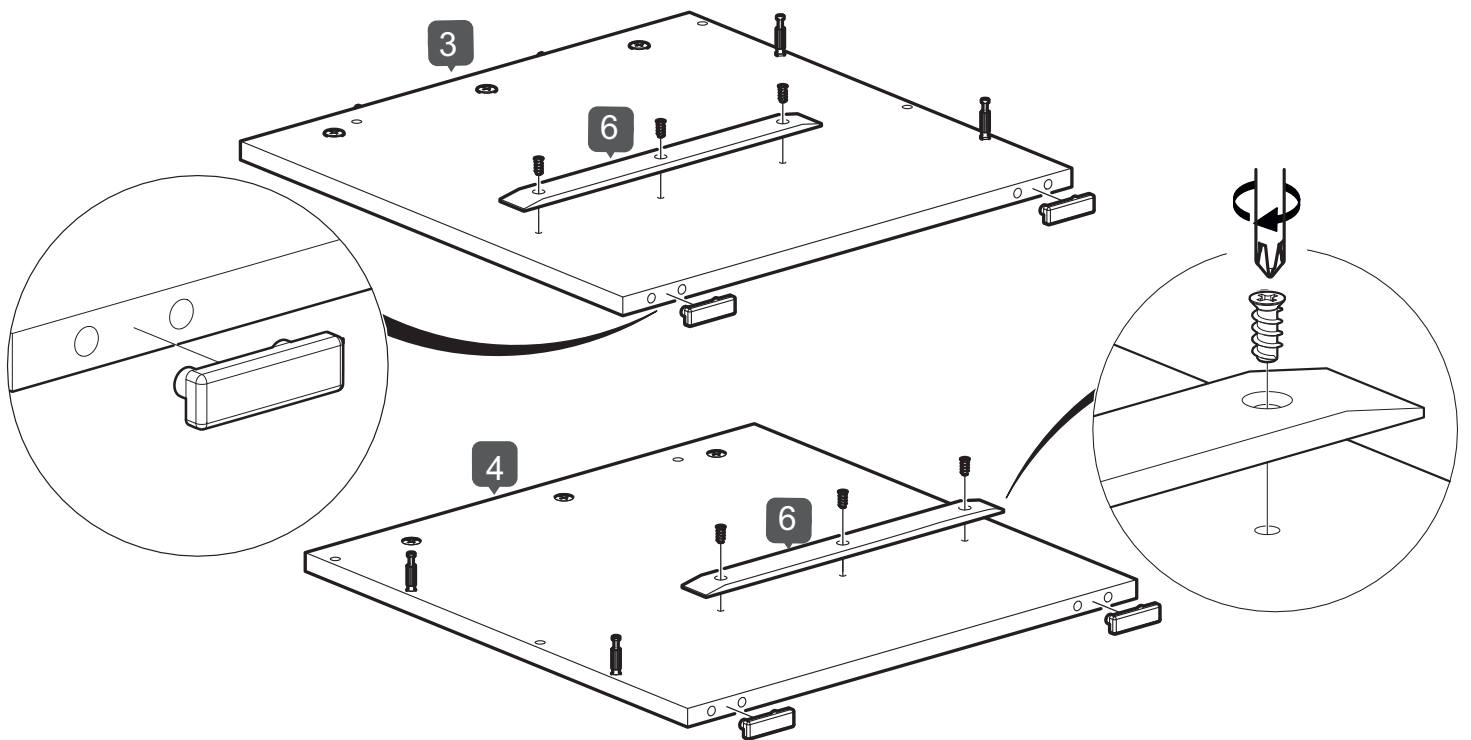

2

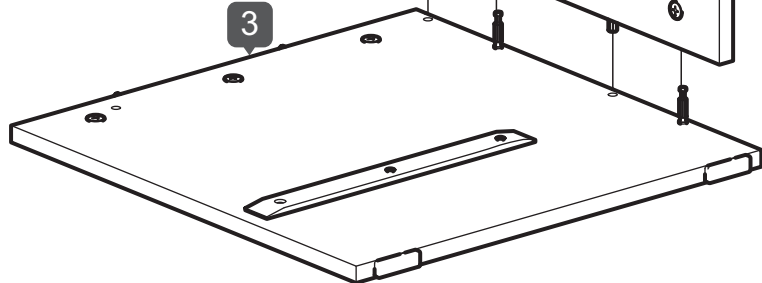
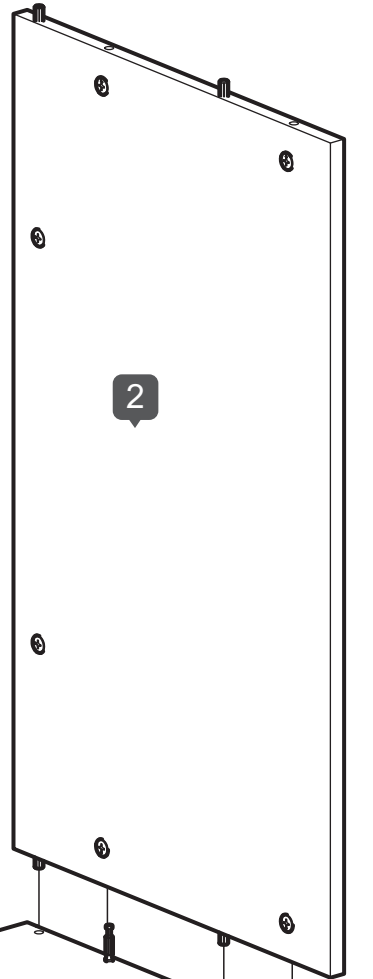
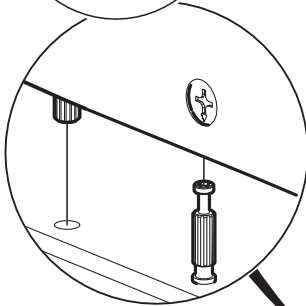
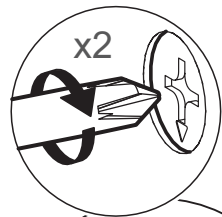
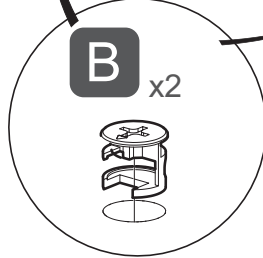
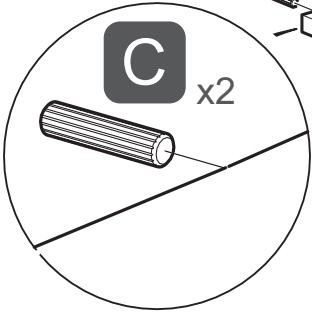
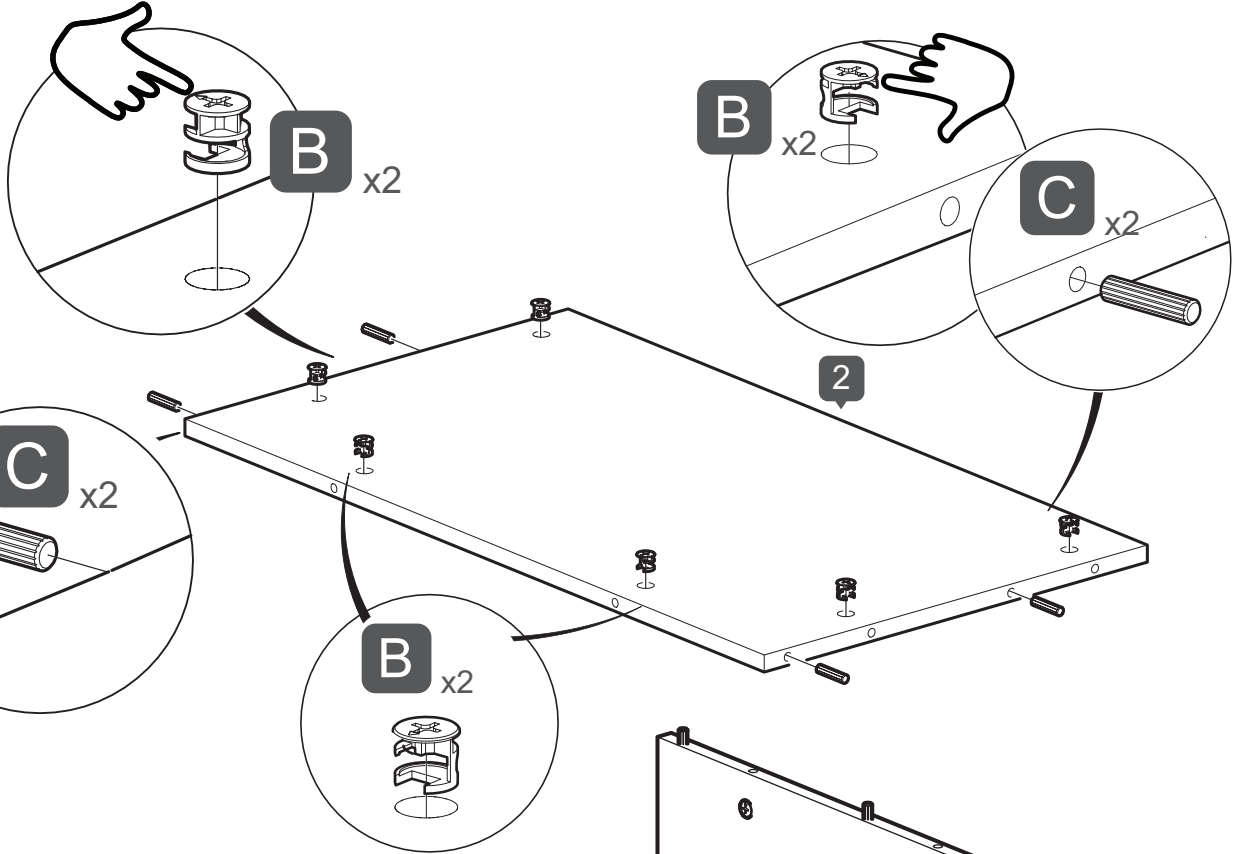

C x4

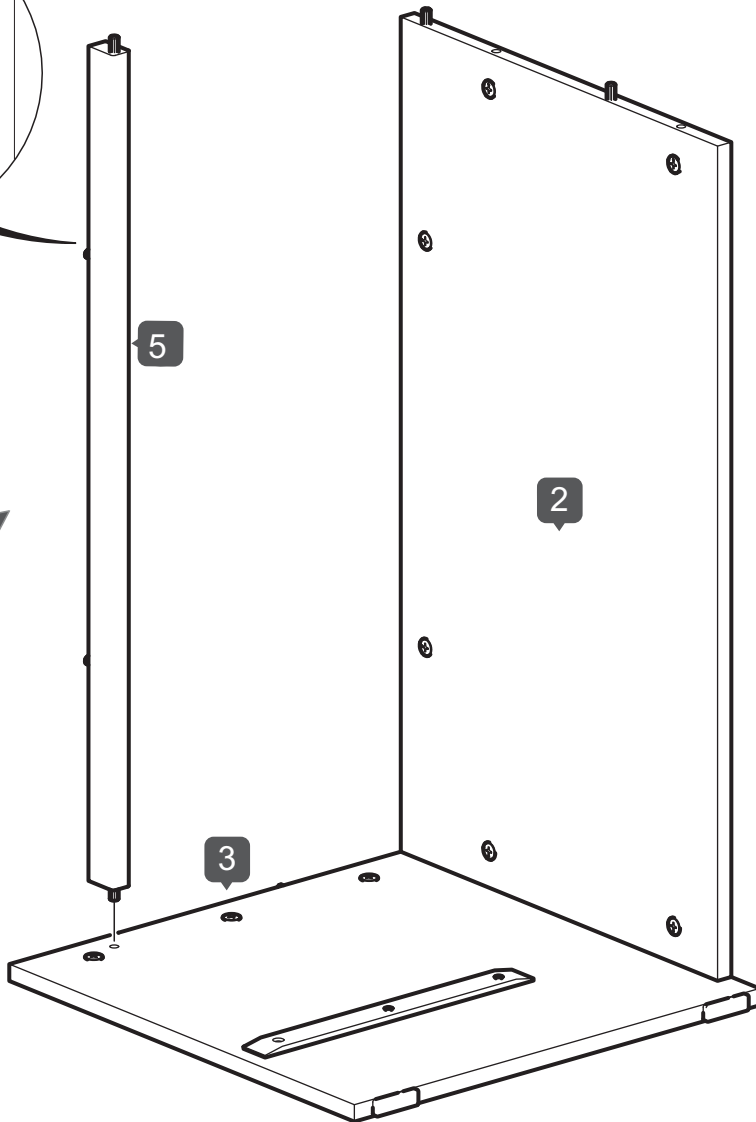
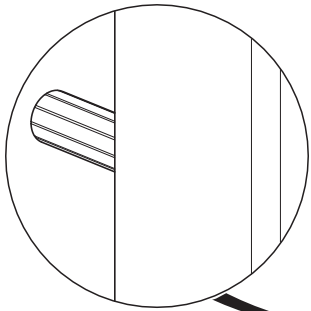
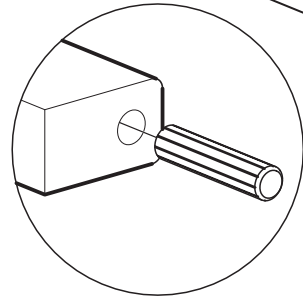
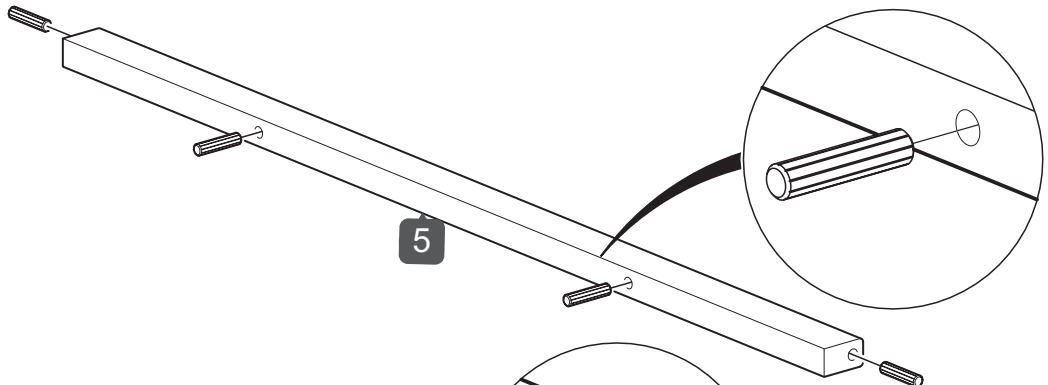
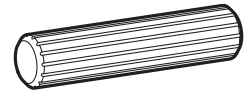

4

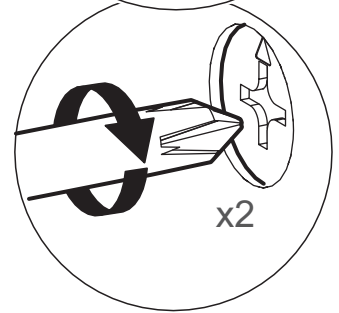
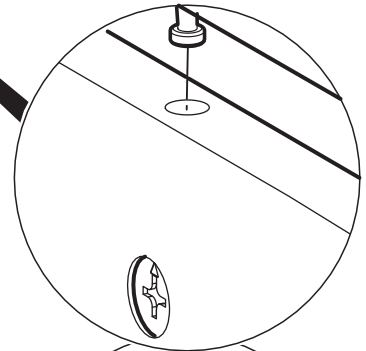
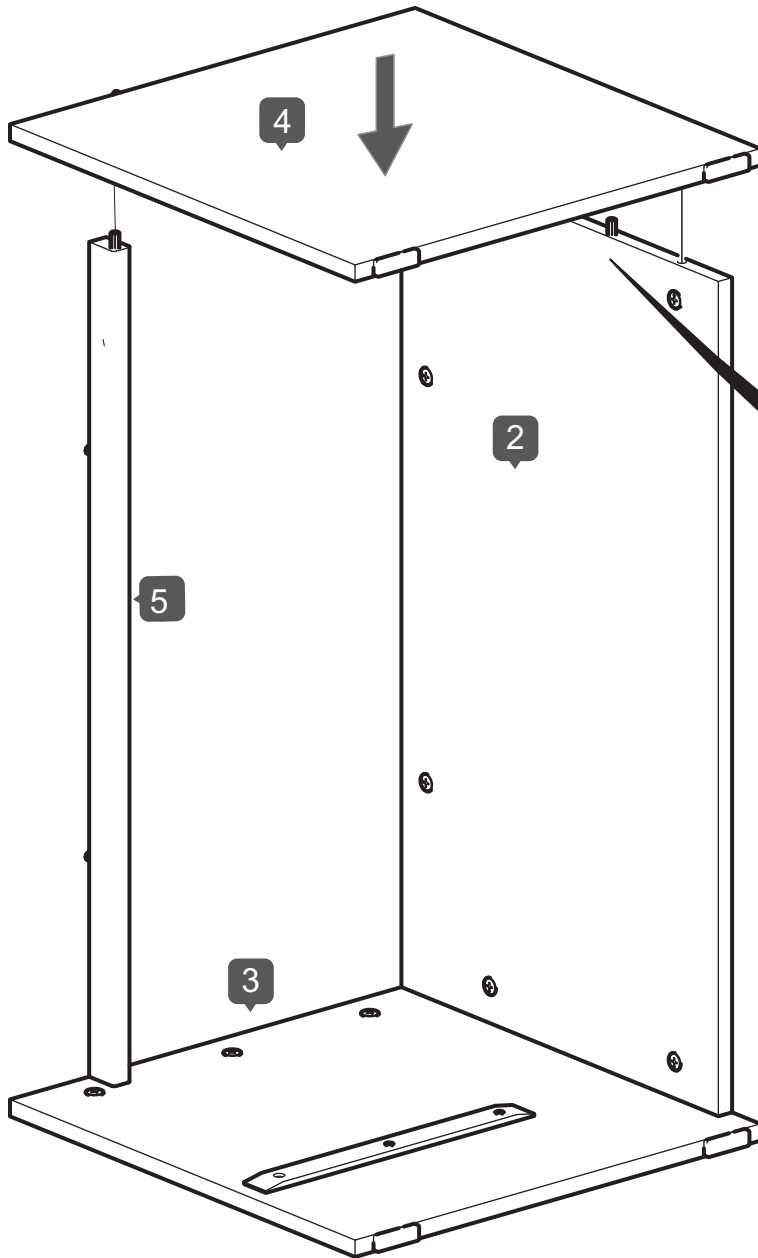

A x8

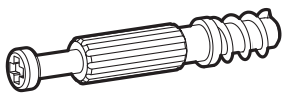

A x8

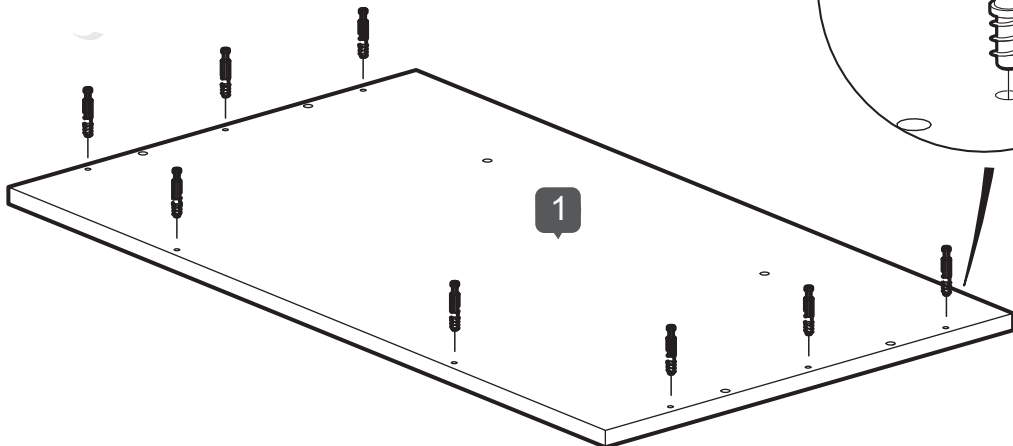
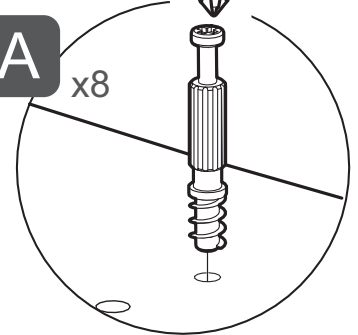

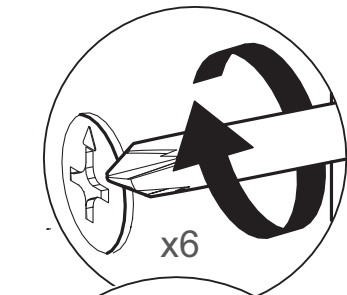
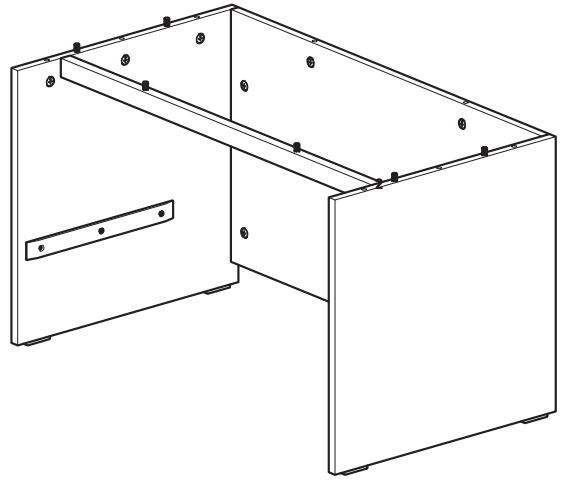
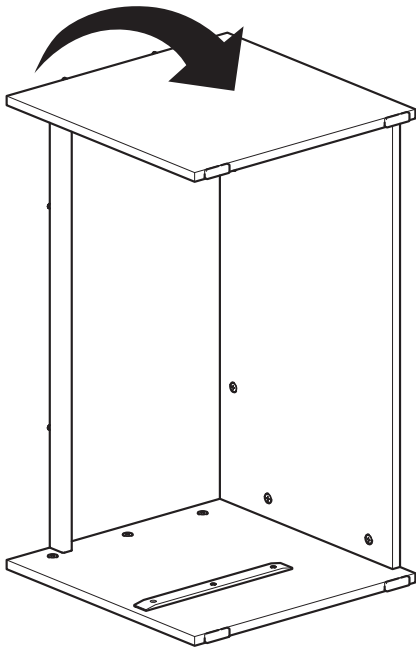

x6

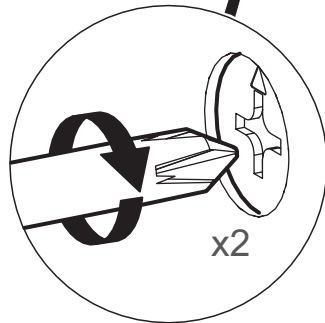
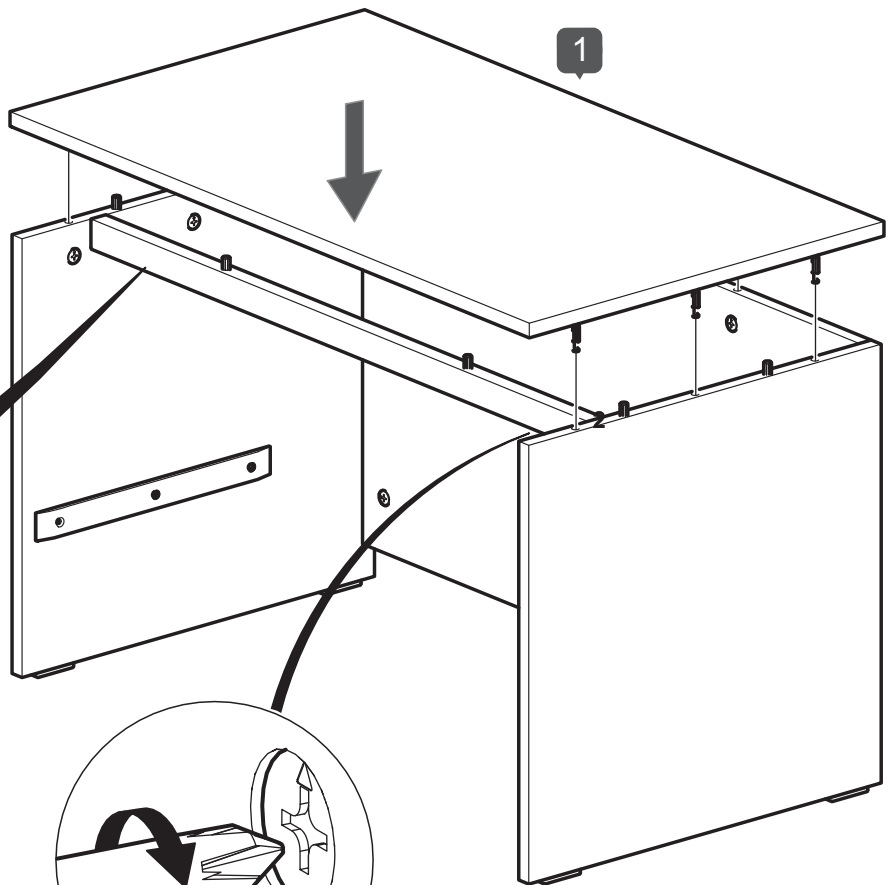
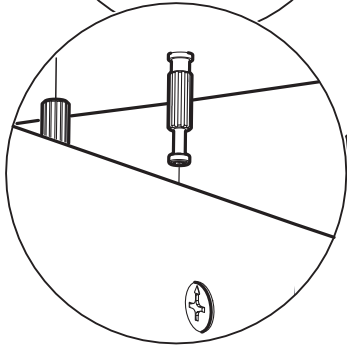

x2

6

B x4

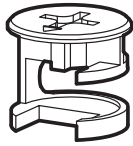

C x4

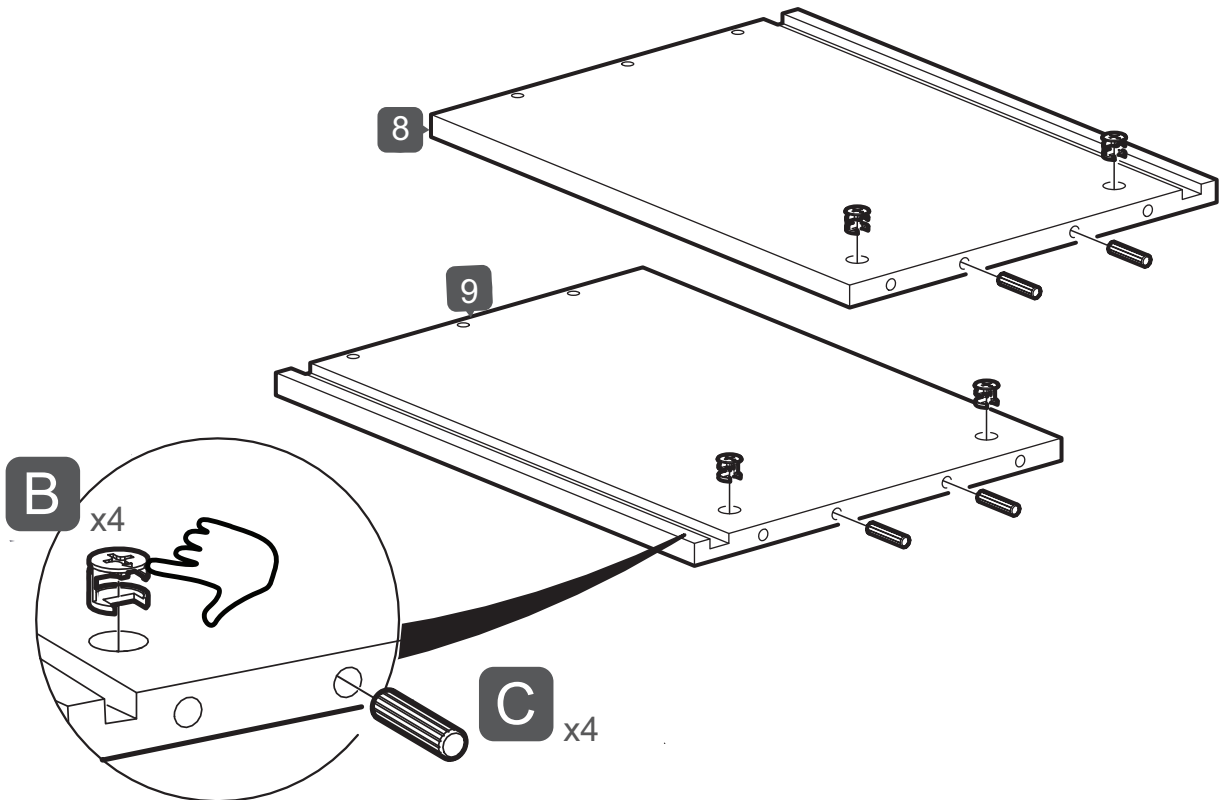
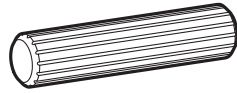

J x1



F x6

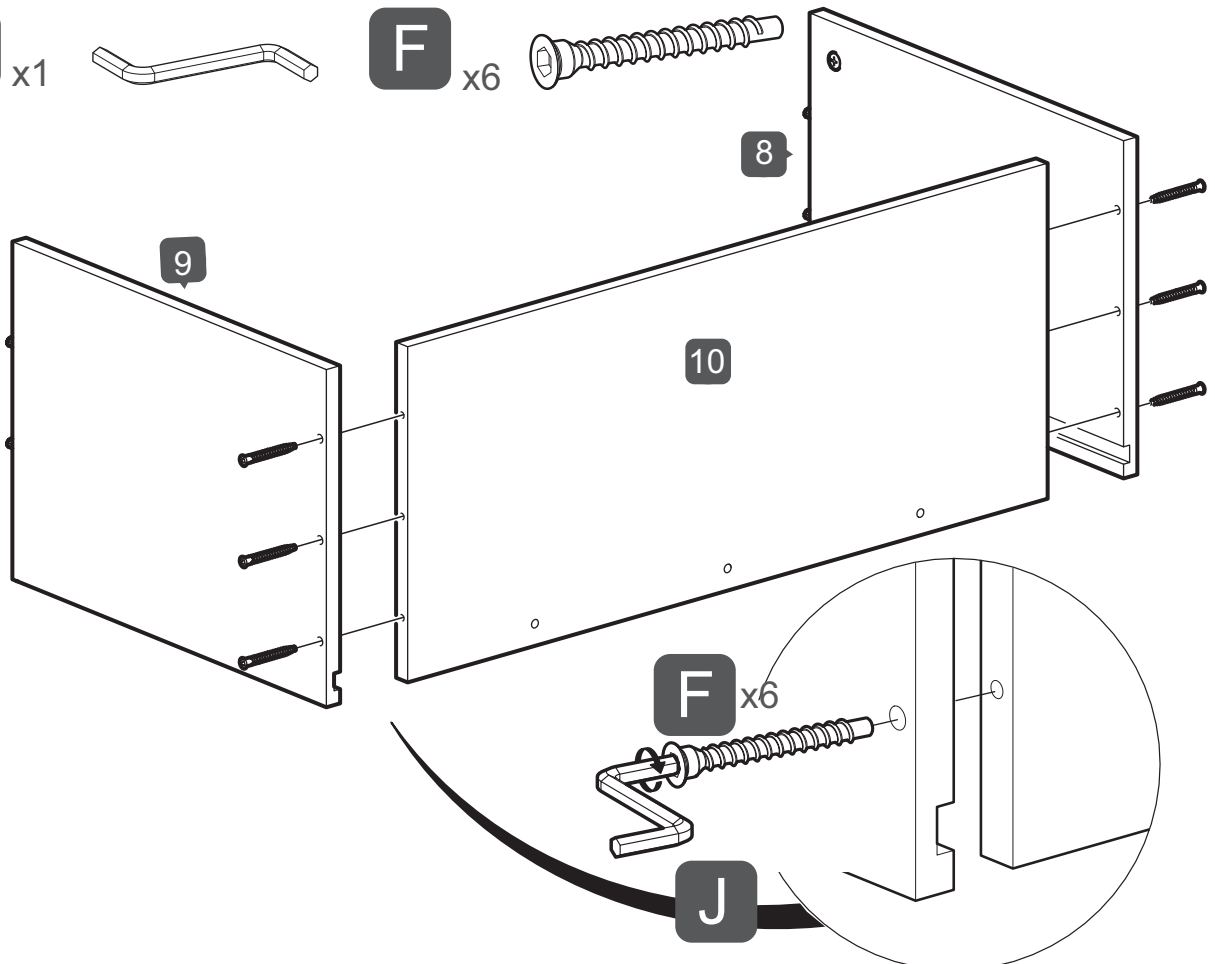
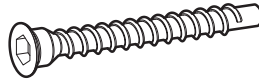

B x3

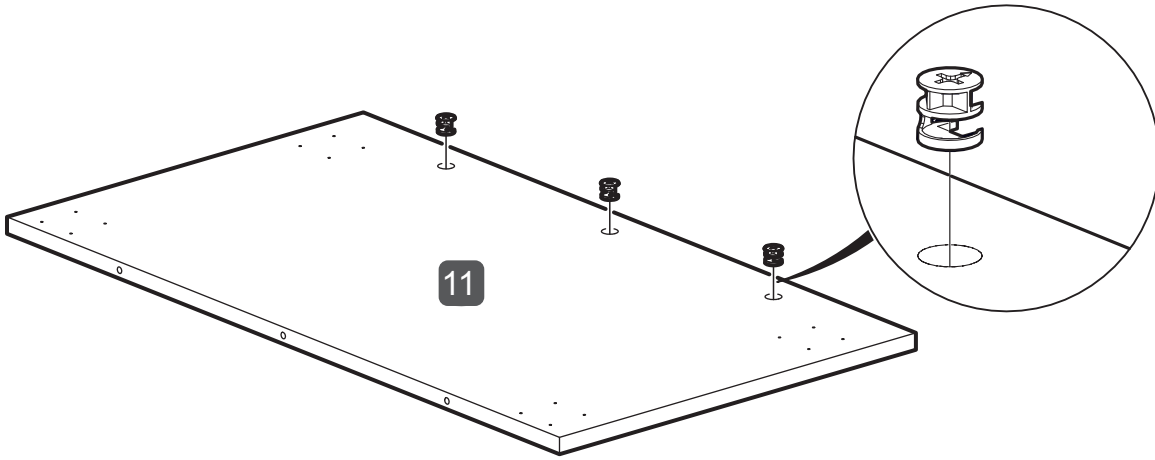
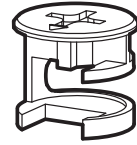

E x16



H x2

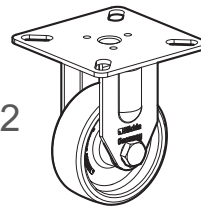

i x2

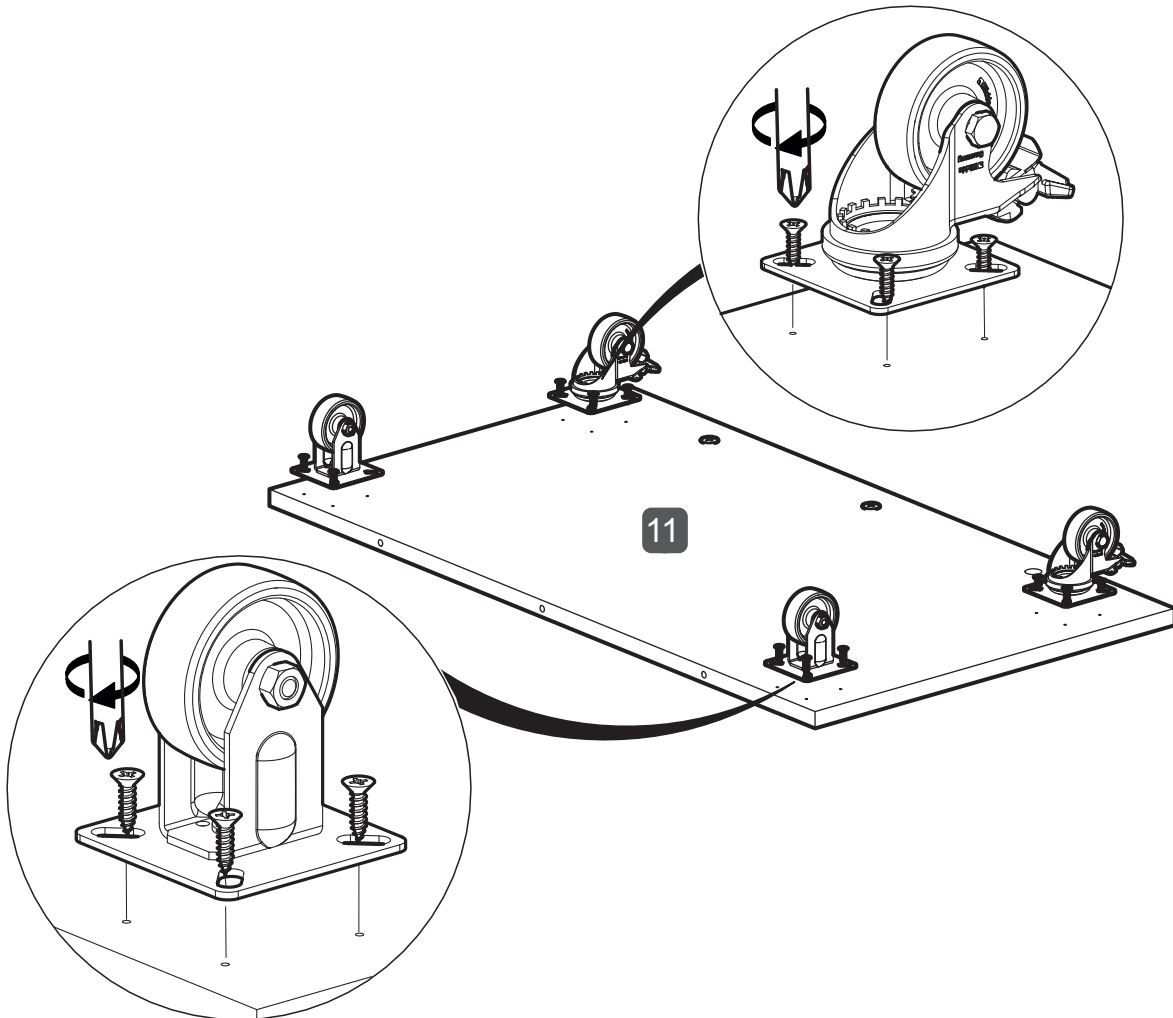
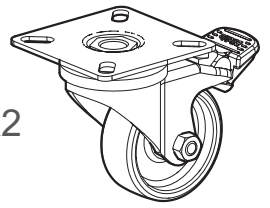

8

A x7

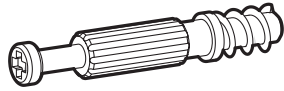

A x7

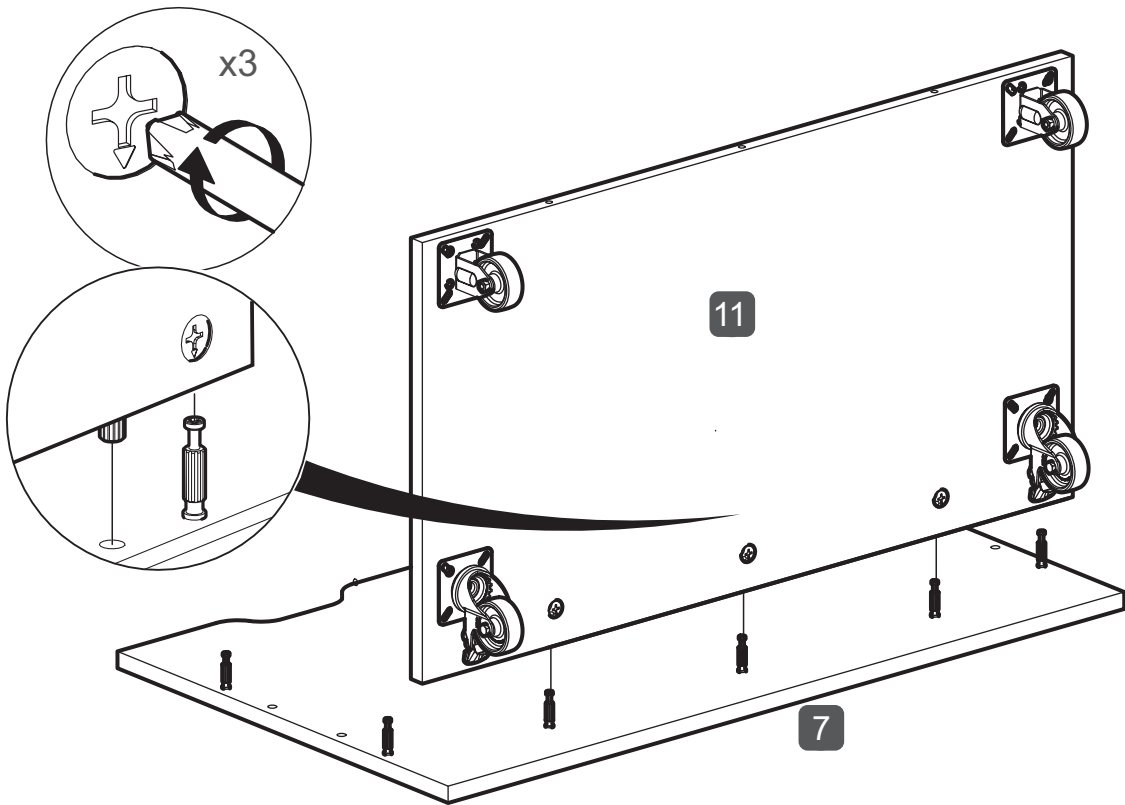
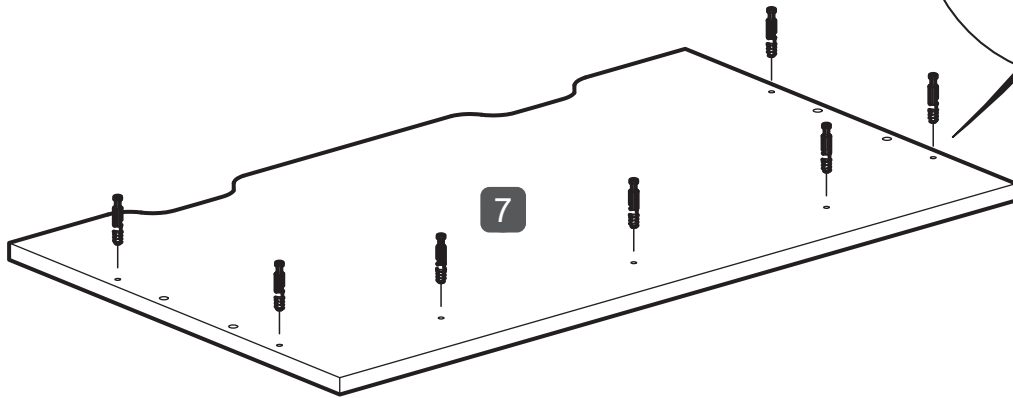
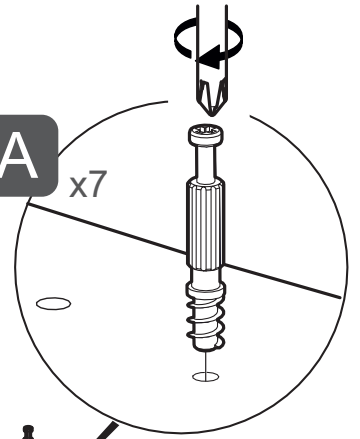

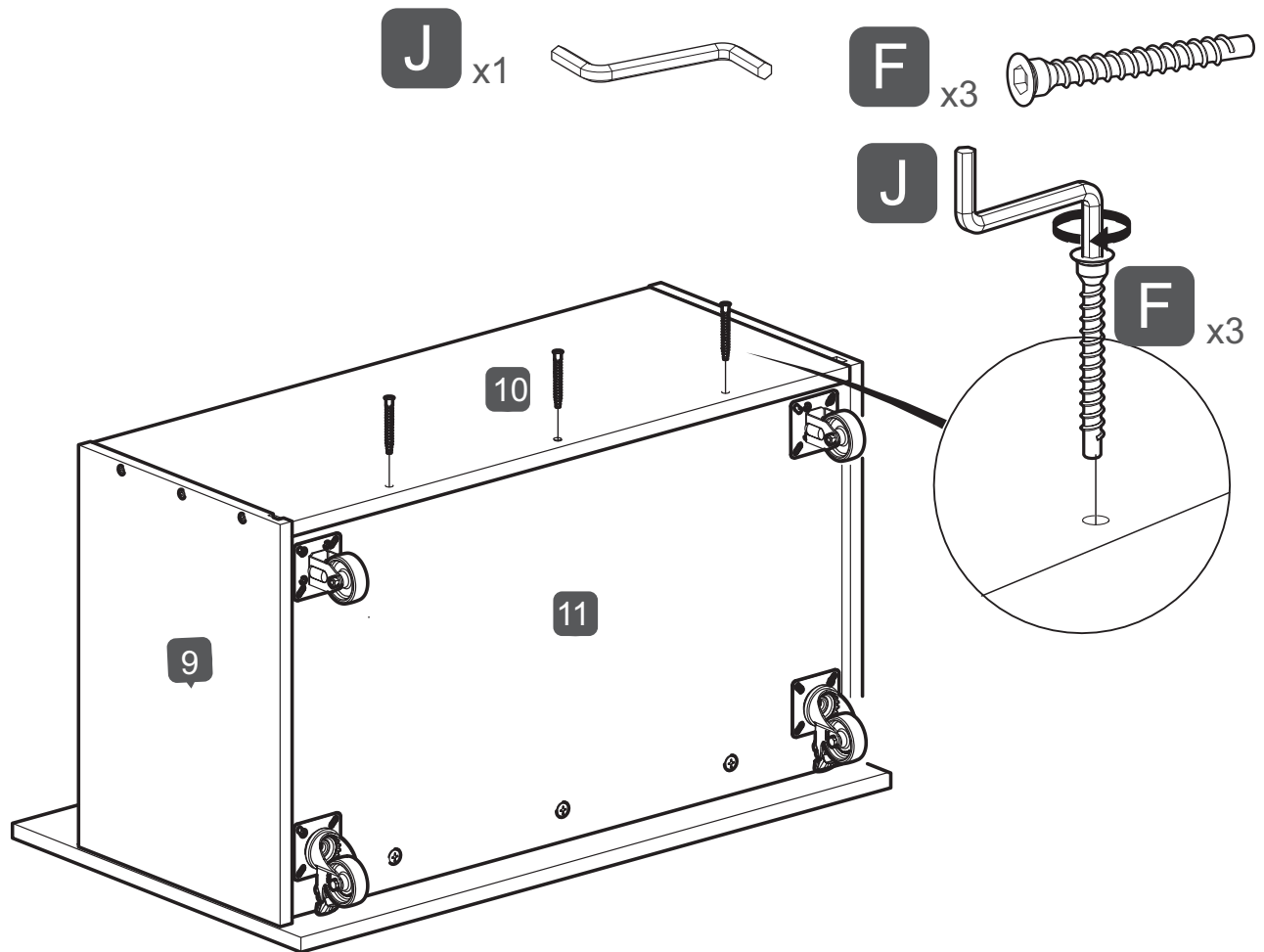
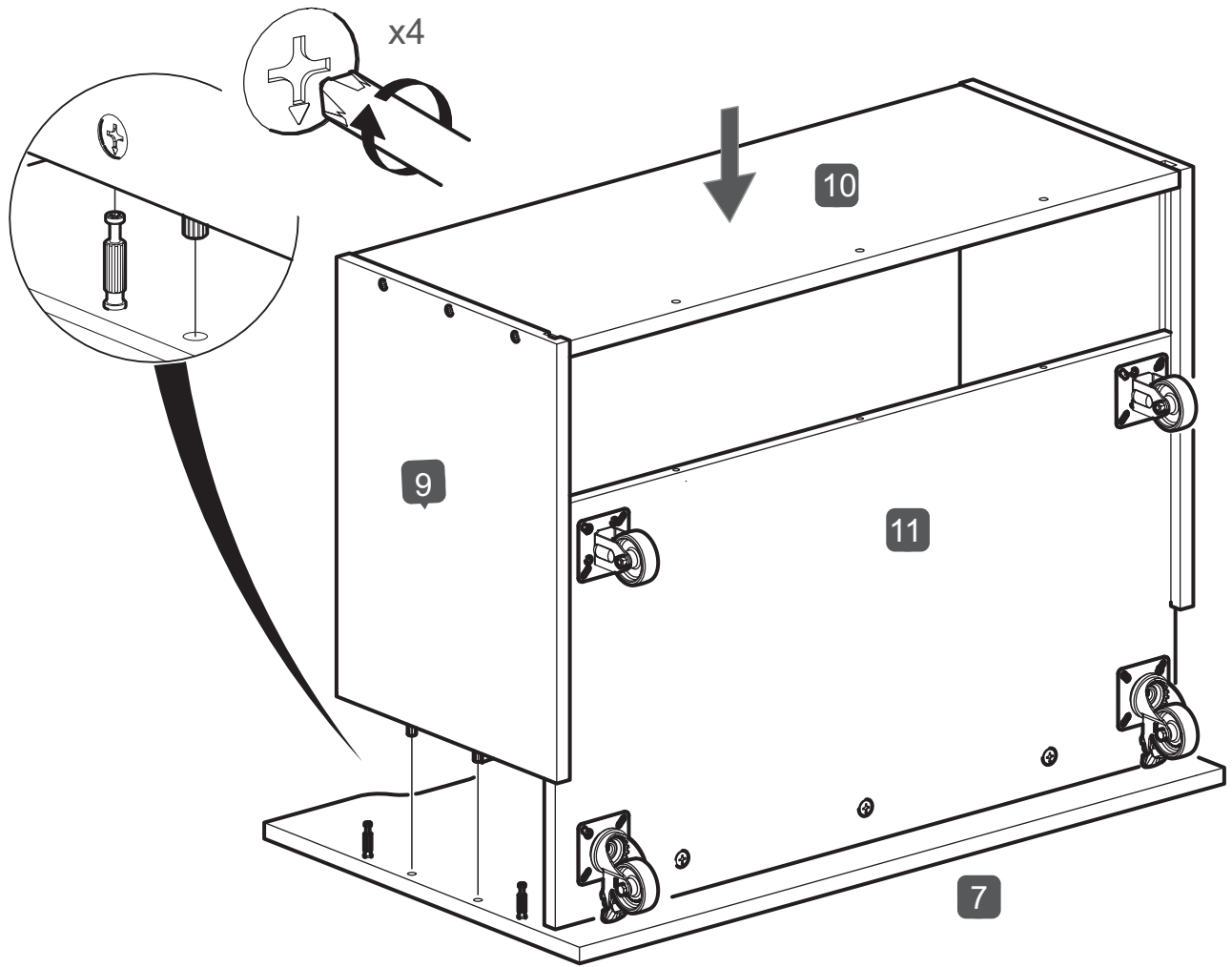

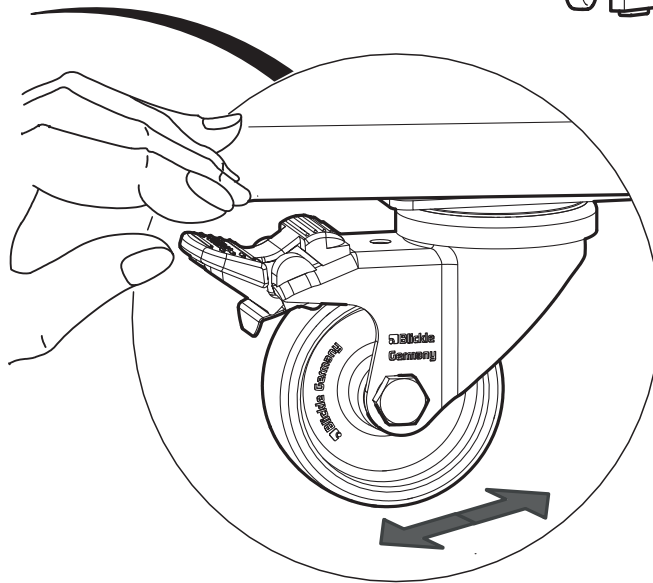
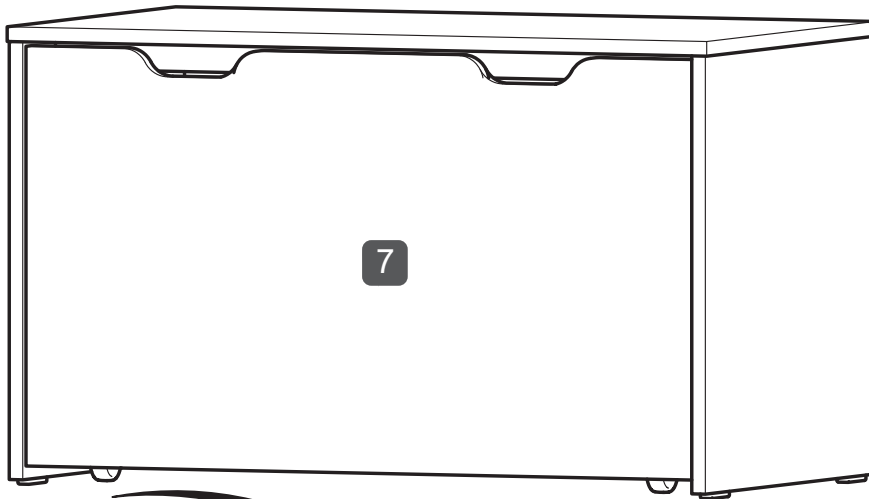
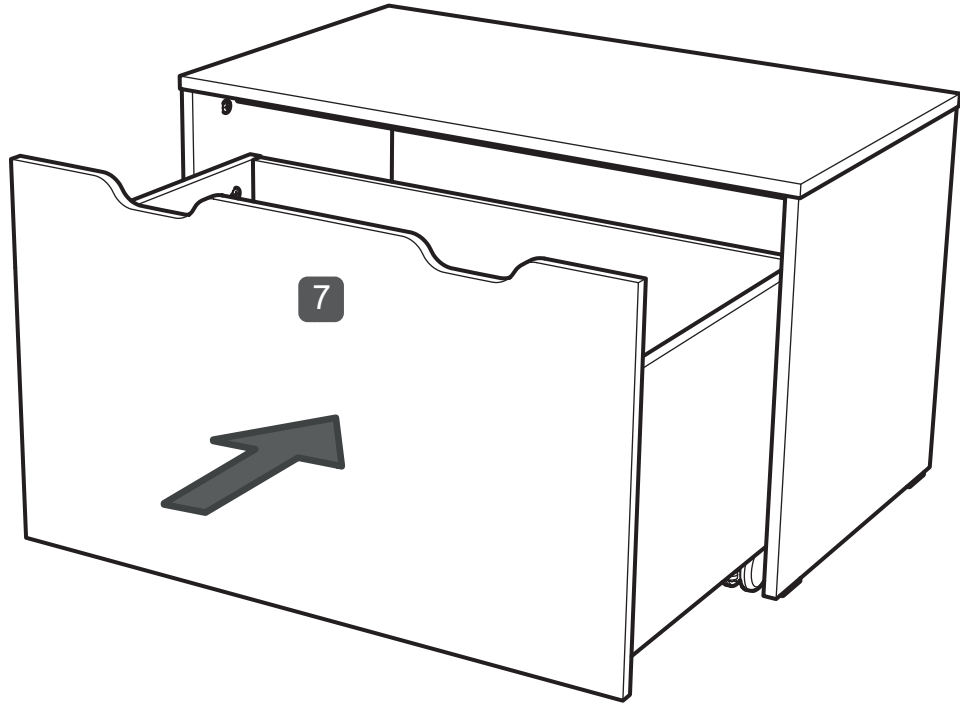

Finished

Concluido

Fini

Fertig

Finito

Voltooid

UK



WARNING:

- DO NOT LEAVE THE CHILD UNATTENDED. The safety of your child is your responsibility
- Do not allow children to play unattended with the storage chest
- Before use, ensure the product is on a stable, level surface.
- Do not allow children to climb on the product.
- Never use your product if any parts are broken or missing.
- Never pivot or drag your product. It must always be lifted by at least two people when being moved.
- Do not place your product in the near vicinity of open fires or other sources of strong heat, such as electric or gas fires.
- Always leave your product clean and dry. Wipe away any spillage straight away. Your product can be cleaned with a damp cloth. Never use abrasive, bleach or strong detergents.
- Check regularly that all fittings and screws are correctly tightened and are not damaged. Loose screws can pinch parts of the body and clothing resulting in the risk of strangulation.

ES



ADVERTENCIA:

- NO DEJE SÓLO LA NIÑO. La seguridad de su hijo es su responsabilidad
- No permita que los niños jueguen sin supervisión con el arcón de almacenaje
- Antes de usarlo, asegúrese de que el producto se halla sobre una superficie estable.
- No permita que los niños se suban a él.
- No utilice el producto si alguna de sus piezas está rota o falta.
- No haga girar nunca el producto sobre sus patas ni lo arrastre. Cuando desee moverlo, al menos dos personas deben elevarlo y transportarlo.
- No coloque el producto cerca de chimeneas u otras fuentes fuertes de calor, como por ejemplo, chimeneas eléctricas o de gas.
- Deje siempre el producto limpio y seco. En caso de que se derrame algún líquido, límpielo inmediatamente. Puede limpiarlo con un trapo húmedo. No utilice nunca limpiadores abrasivos, lejía ni detergentes fuertes.
- Compruebe con regularidad que todas las piezas y tornillos están apretados correctamente y se hallan en buen estado. Los tornillos sueltos pueden pellizcar partes del cuerpo y ropa, con riesgo de estrangulamiento

FR



AVERTISSEMENT! / MISE EN GARDE!

- NE LAISSEZ PAS LA ENFANT SANS SURVEILLANCE. La sécurité de votre enfant relève de votre responsabilité.
- Ne pas laisser les enfants jouer sans surveillance avec le coffre de rangement
- Avant d'utiliser le produit, assurez-vous qu'il se trouve sur une surface stable et horizontale.
- Ne laissez pas les enfants monter sur le produit.
- N'utilisez jamais le produit si une pièce est cassée ou manquante.
- Ne faites jamais pivoter le produit et ne le tirez pas. Il doit être toujours soulevé ou déplacé par au moins deux personnes.
- Ne placez pas le produit à proximité de flammes et d'autres sources de forte chaleur, telles que les appareils de chauffage électrique ou à gaz.
- Gardez toujours le produit propre et sec. Essayez tout de suite tout liquide renversé. Ce produit peut être nettoyé à l'aide d'un chiffon humide. N'utilisez jamais de produits abrasifs ni de détergents concentrés ni d'eau de Javel.
- Vérifiez régulièrement si toutes les pièces de fixation et les vis sont serrées correctement et en bon état. Les vis desserrées risquent de pincer des parties du corps et les vêtements, ce qui entraîne un risque d'étranglement.

D



WARNUNG:

- LASSEN SIE DAS KIND NIEMALS UNBEAUFICHTIGT. Für die Sicherheit Ihres Kindes sind SIE verantwortlich.
- Lassen Sie Ihr Kind nicht unbeaufsichtigt mit dem Aufbewahrungskasten spielen
- Stellen Sie vor der Verwendung sicher, dass sich das Produkt auf einer stabilen, waagerechten Oberfläche befindet.
- Lassen Sie Ihr Kind nicht auf das Produkt klettern.
- Verwenden Sie das Produkt nicht, wenn Teile defekt sind oder fehlen.
- Das Produkt darf nicht gedreht oder gezogen werden. Zum Transportieren muss es immer von mindestens zwei Personen angehoben werden.
- Stellen Sie Ihr Produkt nicht in der unmittelbaren Nähe von offenem Feuer oder anderen intensiven Wärmequellen - wie z. B. Elektro- oder Gasöfen - auf.
- Achten Sie darauf, dass Ihr Produkt immer sauber und trocken ist. Verschüttete Flüssigkeiten müssen immer sofort abgewischt werden. Ihr Produkt kann mit einem feuchten Tuch gereinigt werden. Verwenden Sie niemals Bleich- oder Scheuermittel oder starke Reinigungsmittel.
- Überprüfen Sie regelmäßig, dass die Befestigungen und Schrauben korrekt angezogen und unbeschädigt sind. An lockeren Schrauben können Körperteile und Kleidung hängenbleiben und ein Strangulationsrisiko darstellen.

IT



AVVERTENZA:

- NON LASCIARE IL BAMBINO INCUSTODITO. Il genitore è responsabile della sicurezza del bambino.
- Non permettere ai bambini di giocare con la cassapanca portaoggetti senza la supervisione di un adulto
- Prima dell'uso, verificare che il prodotto sia in posizione stabile e orizzontale.
- Non consentire al bambino di arrampicarsi.
- Non usare mai il prodotto qualora vi fossero componenti mancanti o danneggiati.
- Non ruotare mai o trascinare il prodotto. Sollevarlo sempre con l'aiuto di almeno un'altra persona per spostarlo.
- Non posizionare il prodotto nelle vicinanze di fiamme o altre fonti di calore quali radiatori, fornelli elettrici o a gas.
- Mantenere sempre il prodotto pulito e asciutto. Eliminare immediatamente eventuali liquidi. Pulire con un panno umido. Non applicare mai sbiancanti o detergenti abrasivi.
- Verificare regolarmente che tutti gli attacchi e le viti siano correttamente serrati e in buone condizioni. Le viti allentate possono provocare lesioni sul corpo e sui vestiti del bambino, con il rischio di strangolamento.

NL



WAARSCHUWING:

- LAAT UW KIND NIET ZONDER TOEZICHT ACHTER. De veiligheid van uw kind is uw verantwoordelijkheid.
- Laat kinderen niet zonder toezicht met de opbergkist spelen
- Plaats het product voor gebruik op een stabiele, gelijke ondergrond.
- Laat kinderen niet op het product klimmen.
- Gebruik het product niet als een onderdeel is gebroken of ontbreekt.
- Het product niet om de spil draaien of verslepen. Gebruik bij het verplaatsen van het product altijd minstens twee personen om het op te tillen.
- Plaats het product niet in de buurt van open vuur of andere sterke hittebronnen, zoals elektrische kachels of gaskachels.
- Laat het product altijd schoon en droog achter. Als er op het product gemorst is, maak het dan meteen schoon. Het product kan met een vochtige doek worden afgenomen. Gebruik geen schuur- of bleekmiddelen of andere sterke schoonmaakmiddelen.
- Controleer regelmatig of alle onderdelen en schroeven stevig en goed bevestigd zijn en niet zijn beschadigd. Door losse schroeven kunnen delen van het lichaam en kleding bekneld raken met als gevolg het risico van wurging.



HD5 0RH, UK



mamasandpapas.com
mamasandpapas.ca
mamasandpapas.kr



UK T: +44 (0)345 268 2000
USA T: 1-800-490-0331
CAN T: 1-800-667-4111



/mamasandpapasuk
/mamasandpapasusa
/mamasandpapasmltaregion
/mamasandpapasmagyarország



@mamasandpapas



/user/mamasandpapasglobal



mamasandpapasblog.com



/mamasandpapas



/mamasandpapasuk
/mamasandpapasus



/+mamasandpapas

┌ LOT ┐
└ ┘