

L: Max 720mm – Min 650mm

W: Max 315mm – Min 300mm



x1



<15m

CLSD_0259_1115_V2

© Mamas & Papas Ltd. 2015

**classic mooses
basket stand**

EN **IMPORTANT — READ THE INSTRUCTIONS CAREFULLY BEFORE USE AND KEEP THEM FOR FUTURE REFERENCE**

ES **IMPORTANTE: LEA ESTAS INSTRUCCIONES DETENIDAMENTE Y GUARDELAS PARA FUTURA REFERENCIA**

FR **IMPORTANT : VEUILLEZ LIRE CES CONSIGNES AVEC ATTENTION ET LES CONSERVER POUR VOUS Y REPORTER ULTÉRIEUREMENT**

D **ACHTUNG: BITTE LESEN SIE SICH DIESE ANWEISUNGEN SORGFÄLTIG DURCH UND BEWAHREN SIE SIE FÜR ZUKÜNFTIGE VERWENDUNG AUF**

IT **IMPORTANTE: LEGGERE ATTENTAMENTE QUESTE ISTRUZIONI E CONSERVARLE COME RIFERIMENTO FUTURO.**

NL **BELANGRIJK: LEES, VOORDAT U HET PRODUCT GEBRUIKT, DEZE INSTRUCTIES ZORGVULDIG DOOR EN BEWAAR DEZE VOOR LATERE RAADPLEGING.**

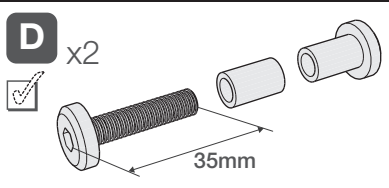
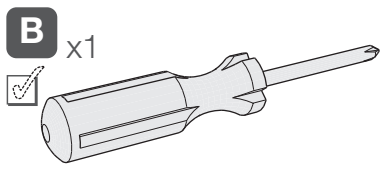
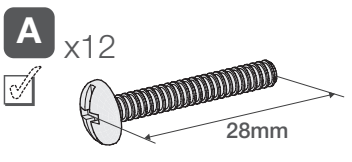
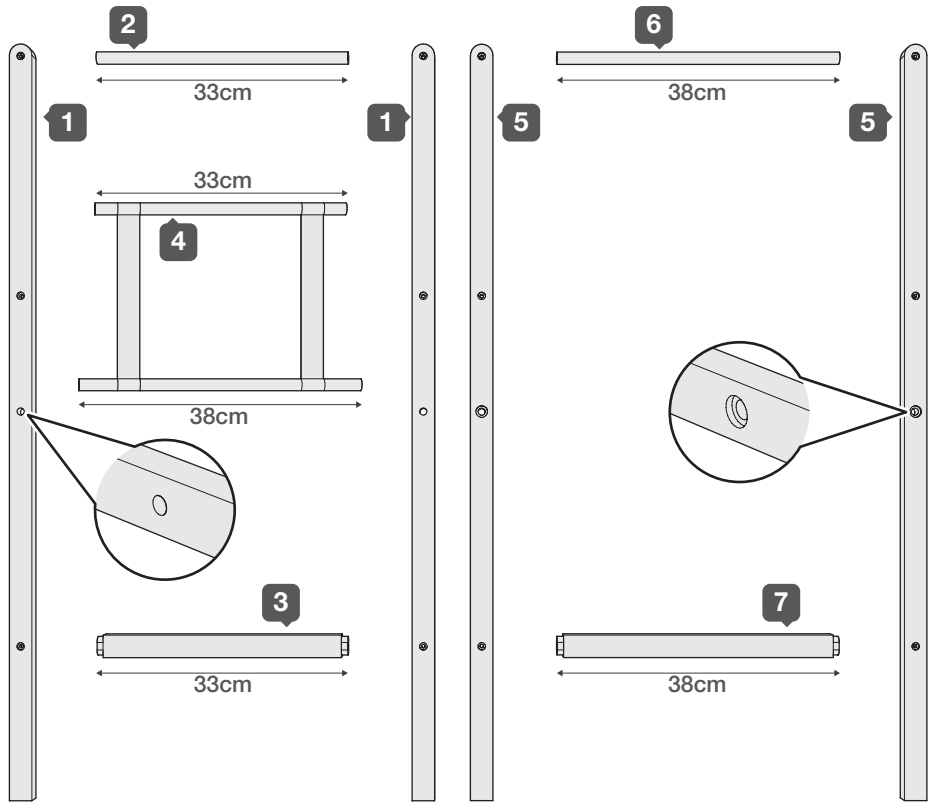

1

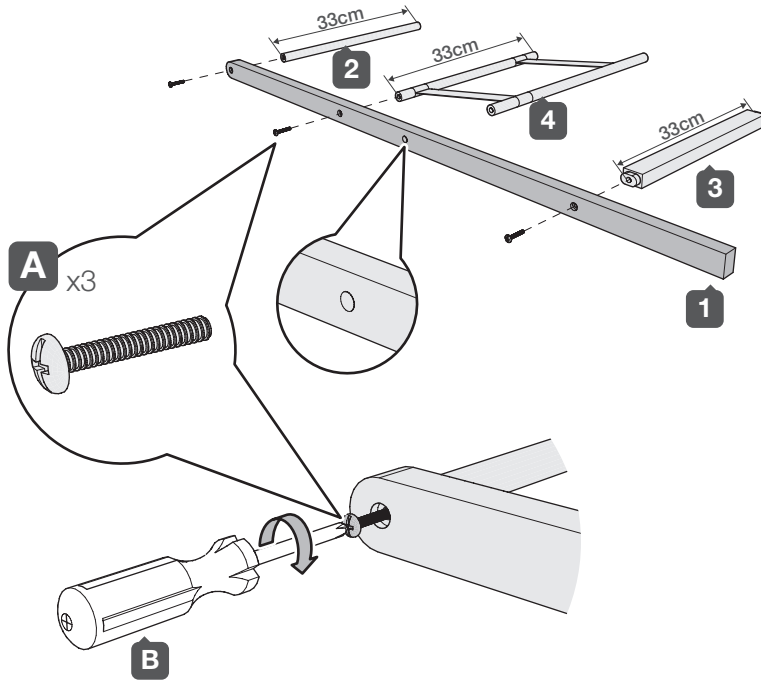

2

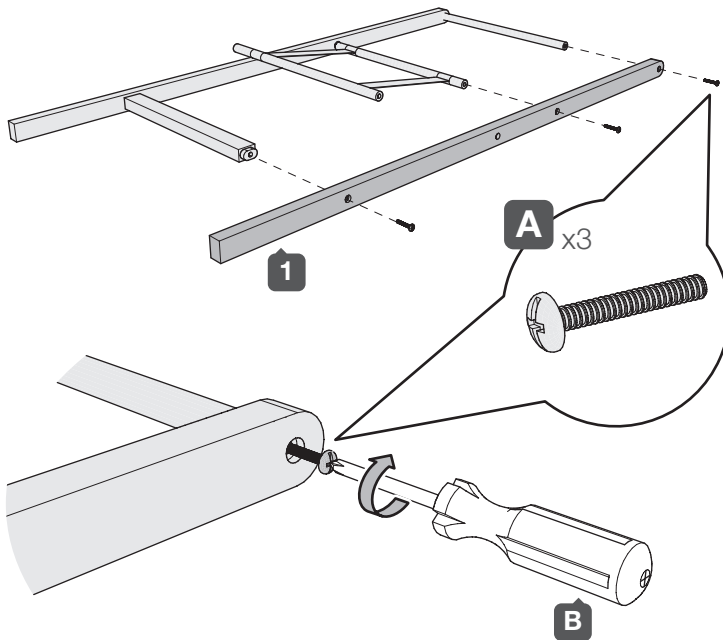

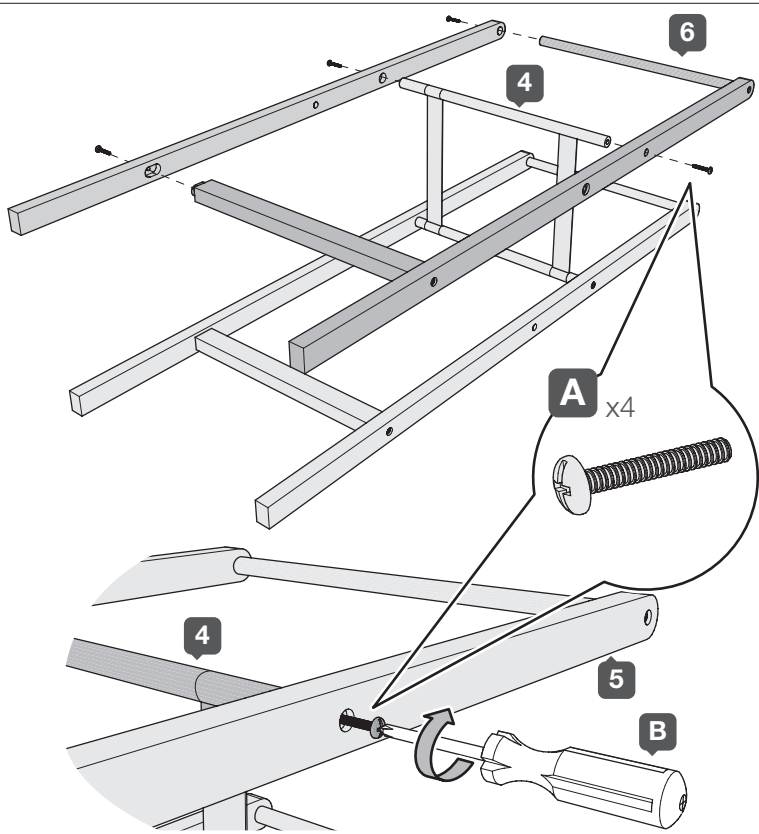
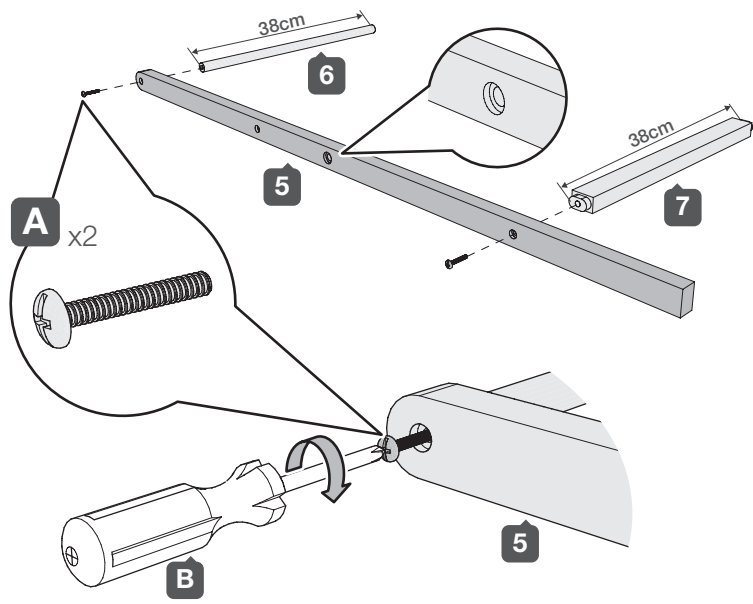

5

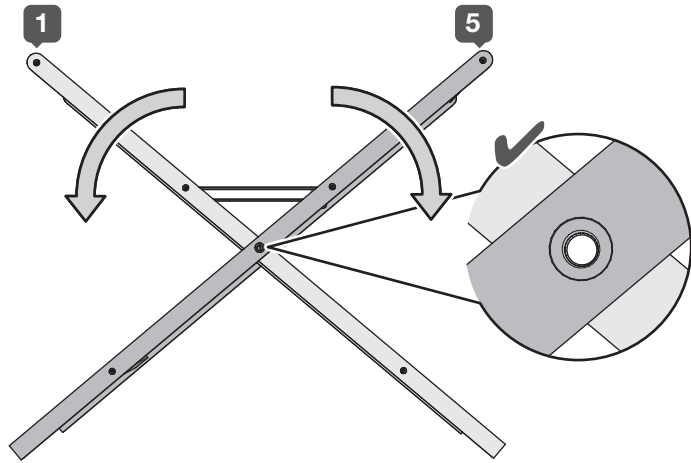

6

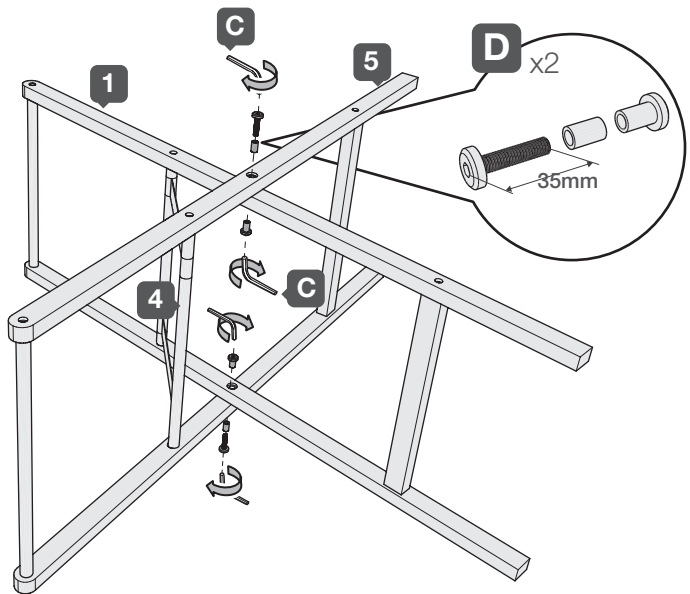
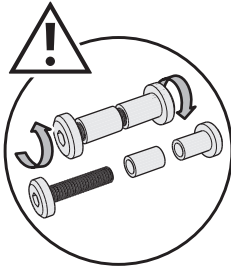

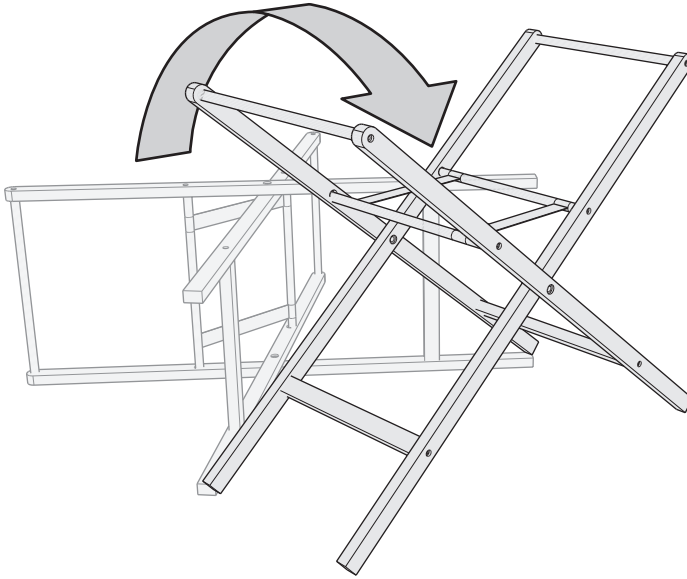

Finished

Concluido

Fini

Fertig

Finito

Voltooid

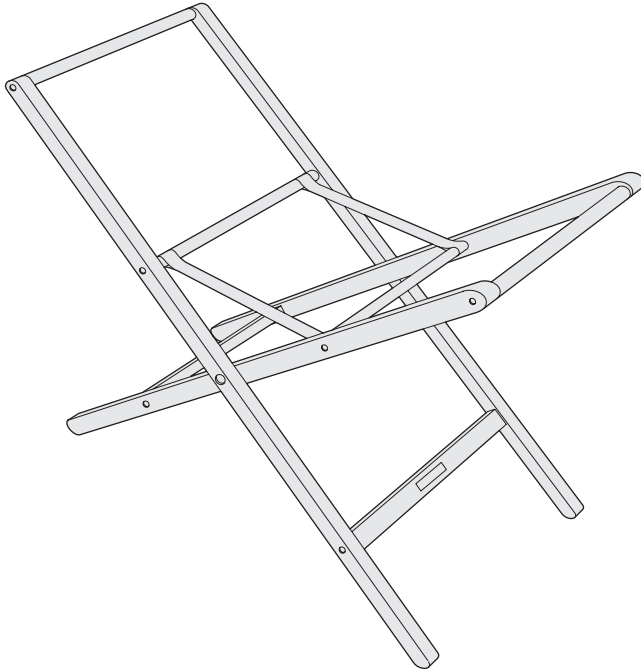

UK

Instructions for safe use

WARNING:

- Use only on firm ground which is horizontal, level and dry.
- Do not let other children play unattended near the carry cot / Moses basket and stand.
- Do not use if any part is broken, torn or missing.

- Only use replacement parts supplied by or approved by Mamas & Papas.
- When the stand is not in use it must be folded or put away.
- Your product can be cleaned with a damp cloth. Never use harsh abrasives, bleach or strong detergents.

FR

Consignes pour un emploi en toute sécurité

AVERTISSEMENT/MISE EN GARDE:

- Poser uniquement sur un sol ferme, horizontal, à niveau et sec.
- Ne pas laisser d'enfants jouer sans surveillance à proximité de la nacelle/du couffin et de son socle.
- Ne pas utiliser si une partie du produit est cassée, déchirée ou manquante.

- Utiliser exclusivement des pièces de rechange fournies ou approuvées par Mamas & Papas.
- Lorsque le socle n'est pas utilisé, celui-ci doit être replié et rangé.
- Le produit peut être nettoyé au chiffon humide. N'utilisez jamais d'abrasifs, d'eau de Javel ou de détergents puissants.

ES

Instrucciones para un uso seguro

ADVERTENCIA:

- Utilizar únicamente en una superficie sólida horizontal llana y seca.
- No permita que otros niños jueguen sin supervisión cerca capazo / Moisés y su soporte.
- No utilice el producto si alguna pieza está rota o estropeada o si falta alguna pieza.

- Utilice exclusivamente piezas de repuesto suministradas o aprobadas por Mamas & Papas.
- Cuando no esté utilizando el soporte, debe plegarlo o guardarlo.
- Puede limpiar el producto con un trapo húmedo. No utilice nunca detergentes fuertes, abrasivos o lejía.

D

Hinweise für eine sichere Verwendung

WARNUNG:

- Nur auf einem festem Boden verwenden, der horizontal, eben und trocken ist.
- Keine anderen Kinder unbeaufsichtigt in der Nähe des Tragebettchens / Babykörbchens und Ständers spielen lassen.
- Nicht benutzen, wenn irgendwelche Teile zerbrochen oder zerrissen sind oder ganz fehlen.

- Verwenden Sie ausschließlich Ersatz- und Zubehörteile, die von Mamas & Papas genehmigt oder geliefert wurden.
- Wenn der Ständer nicht in Gebrauch ist, muss er zusammengeklappt und weggestellt werden.
- Verwenden Sie weder Bleichmittel noch aggressive Scheuermittel oder starke Reinigungsmittel.

IT

Istruzioni per un uso sicuro

AVVERTENZA:

- Utilizzare solo su una superficie solida, asciutta, piatta e orizzontale.
- Non lasciare altri bambini giocare da soli nei pressi della culla/del cestino e della base.
- Non utilizzare in caso di componenti danneggiati, lacerati o mancanti.

- Utilizzare solo i pezzi di ricambio forniti o approvati da Mamas & Papas.
- Se non utilizzata, la base deve essere piegata e riposta.
- Non applicare mai sbiancanti, candeggina o detersivi abrasivi.

NL

Instructies voor veilig gebruik

WAARSCHUWING:

- Gebruik alleen op stevige ondergrond, die horizontaal, gelijk en droog is.
- Laat geen anderen kinderen zonder toezicht in de buurt van de draagwieg / Mozes mandje en standaard spelen.
- Niet gebruiken als een onderdeel gebroken, gescheurd of incompleet is.

- Gebruik alleen vervangende onderdelen die door Mamas & Papas zijn geleverd of goedgekeurd.
- Standaard opvouwen of opbergen als u deze niet gebruikt.
- Gebruik geen agressieve schuur- of bleekmiddelen of andere sterke schoonmaakproducten.

